

Description

The 8T39S04A is a high-performance clock fanout buffer. The input clock can be selected from two differential inputs or one crystal input. The internal oscillator circuit is automatically disabled if the crystal input is not selected. The crystal pin can be driven by a single-ended clock. The selected signal is distributed to four differential outputs which can be configured as LVPECL, LVDS or HSCL outputs. In addition, an LVCMOS output is provided. All outputs can be disabled into a high-impedance state. The device is designed for a signal fanout of high-frequency, low phase-noise clock and data signal. The outputs are at a defined level when inputs are open or tied to ground. It is designed to operate from a 3.3V or 2.5V core power supply, and either a 3.3V or 2.5V output operating supply.

Block Diagram

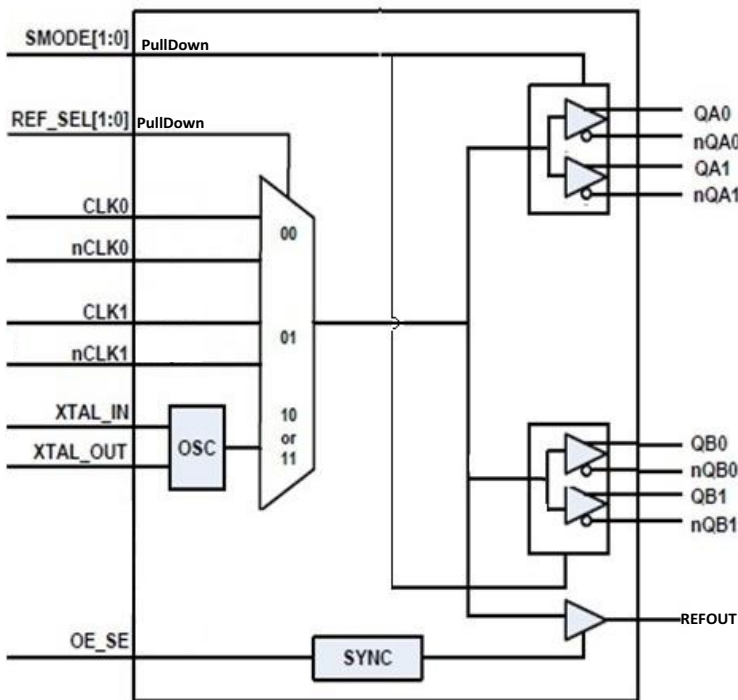

Features

- Two differential reference clock input pairs
- Differential input pairs can accept the following input levels: LVPECL, LVDS, HCSL, HSTL and Single-ended
- Crystal Oscillator Interface
- Crystal input frequency range: 10MHz to 40MHz
- Maximum Output Frequency
 - LVPECL - 2GHz
 - LVDS - 2GHz
 - HCSL - 250MHz
 - LVCMOS - 250MHz
- Two banks, each has two differential output pairs that can be configured as LVPECL or LVDS or HCSL
- One single-ended reference output with synchronous enable to avoid clock glitch
- Output skew: 80ps (maximum), Bank A and Bank B at the same output level
- Part-to-part skew: 200ps (typical), design target
- Additive RMS phase jitter @ 156.25MHz, (12kHz - 20MHz): 34.7fs (typical), 3.3V/ 3.3V
- Supply voltage modes:
 - V_{DD}/V_{DDO}
 - 3.3V/3.3V
 - 3.3V/2.5V
 - 2.5V/2.5V
- -40°C to 85°C ambient operating temperature
- Lead-free (RoHS 6) packaging

Pin Assignment

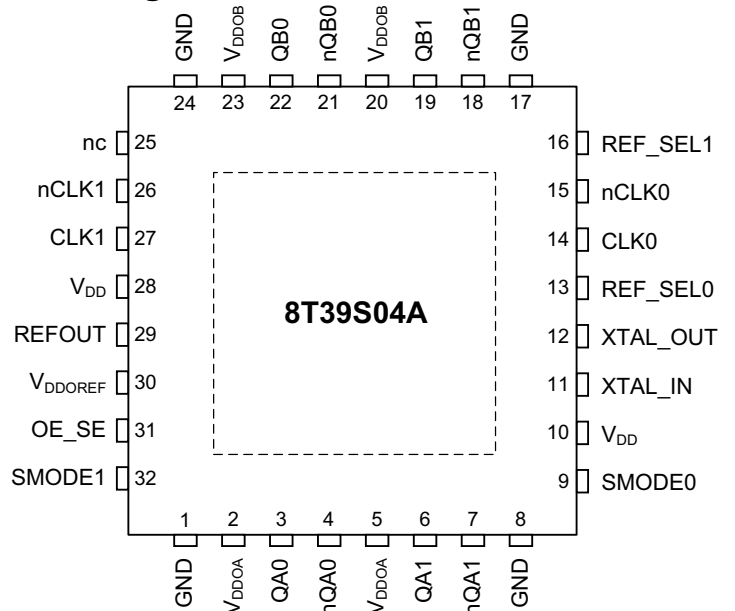

32-pin, 5mm x 5mm VFQFN Package

Pin Description and Pin Characteristic Table

Table 1. Pin Descriptions

Number	Name	Type		Description
1	GND	Power		Power supply ground.
2	V _{DDOA}	Power		Output supply pin for Bank QA outputs.
3	QA0	Output		Differential Bank A clock output pair. LVPECL, LVDS or HCSL interface levels.
4	nQA0	Output		Differential Bank A clock output pair. LVPECL, LVDS or HCSL interface levels.
5	V _{DDOA}	Power		Output supply pin for Bank QA outputs.
6	QA1	Output		Differential Bank A clock output pair. LVPECL, LVDS or HCSL interface levels.
7	nQA1	Output		Differential Bank A clock output pair. LVPECL, LVDS or HCSL interface levels.
8	GND	Power		Power supply ground.
9	SMODE0	Input	Pulldown	Output driver select for Bank A and Bank B outputs. See Table 3D for function. LVCMOS/LVTTL interface levels.
10	V _{DD}	Power		Power supply pin.
11	XTAL_IN	Input		Crystal oscillator interface.
12	XTAL_OUT	Output		Crystal oscillator interface.
13	REF_SEL0	Input	Pulldown	Input clock selection. LVCMOS/LVTTL interface levels. See Table 3A for function.
14	CLK0	Input	Pullup/ Pulldown	Non-inverting differential clock. Internally biased to 0.33V _{DD} .
15	nCLK0	Input	Pullup/ Pulldown	Inverting differential clock. Internal resistor bias to 0.4V _{DD} .
16	REF_SEL1	Input	Pulldown	Input clock selection. LVCMOS/LVTTL interface levels. See Table 3A for function.
17	GND	Power		Power supply ground.
18	nQB1	Output		Differential Bank B clock output pair. LVPECL, LVDS or HCSL interface levels.
19	QB1	Output		Differential Bank B clock output pair. LVPECL, LVDS or HCSL interface levels.
20	V _{DDOB}	Power		Output supply pin for Bank QB outputs.
21	nQB0	Output		Differential Bank B clock output pair. LVPECL, LVDS or HCSL interface levels.
22	QB0	Output		Differential Bank B clock output pair. LVPECL, LVDS or HCSL interface levels.
23	V _{DDOB}	Power		Output supply pin for Bank QB outputs.
24	GND	Power		Power supply ground.
25	nc	Unused		No connect pin.
26	nCLK1	Input	Pullup/ Pulldown	Inverting differential clock. Internal resistor bias to 0.4V _{DD} .
27	CLK1	Input	Pullup/ Pulldown	Non-inverting differential clock. Internally biased to 0.33V _{DD} .
28	V _{DD}	Power		Power supply pin.
29	REFOUT	Output		Single-ended reference clock output. LVCMOS/LVTTL interface levels.
30	V _{DDOREF}	Power		Output supply pin for REFOUT output.
31	OE_SE	Input	Pulldown	Output enable. LVCMOS/LVTTL interface levels. See Table 3B.
32	SMODE1	Input	Pulldown	Output driver select for Bank A and Bank B outputs. See Table 3D for function. LVCMOS/LVTTL interface levels.
0	ePAD	Power		Connect ePAD to ground to ensure proper heat dissipation.

NOTE: *Pulldown* and *Pullup* refer to internal input resistors. See Table 2, *Pin Characteristics*, for typical values.

Table 2. Pin Characteristics

Symbol	Parameter		Test Conditions	Minimum	Typical	Maximum	Units
C_{IN}	Input Capacitance	OE_SE, SMODE[1:0], REF_SEL[1:0]			2		pF
$R_{PULLDOWN}$	Input Pulldown Resistor				50		k Ω
R_{PULLUP}	Input Pullup Resistor	CLK0, CLK1			100		k Ω
		nCLK0, nCLK1			75		k Ω
C_{PD}	Power Dissipation Capacitance	REFOUT	$V_{DDOREF} = 3.465V$		5.3		pF
			$V_{DDOREF} = 2.625V$		6.3		pF
R_{OUT}	Output Impedance	REFOUT	$V_{DDOREF} = 3.3V$		52		Ω
			$V_{DDOREF} = 2.5V$		63		Ω

Function Tables

Table 3A. REF_SELx Function Table

Control Input	Selected Input Reference Clock
REF_SEL[1:0]	
00 (default)	CLK0, nCLK0
01	CLK1, nCLK1
10	XTAL
11	XTAL

Table 3B. OE_SE Function Table

OE_SE	REFOUT
0 (default)	High-Impedance
1	Enabled

NOTE: Synchronous output enable to avoid clock glitch.

Table 3C. Input/Output Operation Table, OE_SE

Input Status			Output State
OE_SE	REF_SEL [1:0]	CLKx and nCLKx	REFOUT
0 (default)	Don't care	Don't Care	High Impedance
1	10 or 11	Don't Care	Fanout Crystal Oscillator
1	00 (default)	CLK0 and nCLK0 are both open circuit	Logic Low
		CLK0 and nCLK0 are tied to ground	Logic Low
		CLK0 is high, nCLK0 is low	Logic High
		CLK0 is low, nCLK0 is high	Logic Low
1	01	CLK1 and nCLK1 are both open circuit	Logic Low
		CLK1 and nCLK1 are tied to ground	Logic Low
		CLK1 is high, nCLK1 is low	Logic High
		CLK1 is low, nCLK1 is high	Logic Low

Table 3D. Output Level Selection Table, QX[0:1], nQX[0:1]

S.MODE1	S.MODE0	Output Type
0	0	LVPECL (default)
0	1	LVDS
1	0	HCSL
1	1	High-Impedance

NOTE: X denotes A and B.

Table 3E. Input/Output Operation Table, SMODE[1:0]

Input Status			Output State
SMODE[1:0]	REF_SEL[1:0]	CLKx and nCLKx	QA[1:0], nQA[1:0]
11	Don't care	Don't Care	High Impedance
00, 01 or 10	10 or 11	Don't Care	Fanout crystal oscillator
00, 01 or 10	00 (default)	CLK0 and nCLK0 are both open circuit	QA[1:0] = Low nQA[1:0] = High
		CLK0 and nCLK0 are tied to ground	QA[1:0] = Low nQA[1:0] = High
		CLK0 is high, nCLK0 is low	QA[1:0] = High nQA[1:0] = Low
		CLK0 is low, nCLK0 is high	QA[1:0] = Low nQA[1:0] = High
00, 01 or 10	01	CLK1 and nCLK1 are both open circuit	QA[1:0] = Low nQA[1:0] = High
		CLK1 and nCLK1 are tied to ground.	QA[1:0] = Low nQA[1:0] = High
		CLK1 is high, nCLK1 is low	QA[1:0] = High nQA[1:0] = Low
		CLK1 is low, nCLK1 is high	QA[1:0] = Low nQA[1:0] = High

Table 3F. Input/Output Operation Table, SMODE[1:0]

Input Status			Output State
SMODE[1:0]	REF_SEL[1:0]	CLKx and nCLKx	QB[1:0], nQB[1:0]
11	Don't care	Don't Care	High Impedance
00, 01 or 10	10 or 11	Don't Care	Fanout Crystal Oscillator
00, 01 or 10	00 (default)	CLK0 and nCLK0 are both open circuit	QB[1:0] = Low nQB[1:0] = High
		CLK0 and nCLK0 are tied to ground	QB[1:0] = Low nQB[1:0] = High
		CLK0 is high, nCLK0 is low	QB[1:0] = High nQB[1:0] = Low
		CLK0 is low, nCLK0 is high	QB[1:0] = Low nQB[1:0] = High
00, 01 or 10	01	CLK1 and nCLK1 are both open circuit	QB[1:0] = Low nQB[1:0] = High
		CLK1 and nCLK1 are tied to ground	QB[1:0] = Low nQB[1:0] = High
		CLK1 is high, nCLK1 is low	QB[1:0] = High nQB[1:0] = Low
		CLK1 is low, nCLK1 is high	QB[1:0] = Low nQB[1:0] = High

Absolute Maximum Ratings

NOTE: Stresses beyond those listed under *Absolute Maximum Ratings* may cause permanent damage to the device. These ratings are stress specifications only. Functional operation of the product at these conditions or any conditions beyond those listed in the *DC Characteristics* or *AC Characteristics* is not implied. Exposure to absolute maximum rating conditions for extended periods may affect product reliability.

Item	Rating
Supply Voltage, V_{DD}	4.6V
Inputs, V_I XTAL_IN Other Inputs	0V to 2V -0.5V to $V_{DD} + 0.5V$
Outputs, V_O , (HCSL, LVCMOS)	-0.5V to $V_{DDOX}^1 + 0.5V$
Outputs, I_O , (LVPECL) Continuous Current Surge Current	50mA 100mA
Outputs, I_O , (LVDS) Continuous Current Surge Current	10mA 15mA
Maximum Junction Temperature, $T_{J,MAX}$	150°C
Storage Temperature, T_{STG}	-65°C to 150°C

NOTE 1. V_{DDOX} denotes V_{DDOA} , V_{DDOB} and V_{DDOREF} .

Recommended Operating Conditions

Symbol	Parameter	Minimum	Typical	Maximum	Units
T_A	Ambient air temperature	-40		85	°C
T_J	Junction temperature			125	°C

DC Electrical Characteristics

Table 4A. Power Supply DC Characteristics, $V_{DD} = V_{DDOA} = V_{DDOB} = V_{DDOREF} = 3.3V \pm 5\%$, GND = 0V, $T_A = -40^\circ\text{C}$ to 85°C

Symbol	Parameter	Test Conditions	Minimum	Typical	Maximum	Units
V_{DD}	Power Supply Voltage		3.135	3.3	3.465	V
V_{DDOA} , V_{DDOB} , V_{DDOREF}	Output Supply Voltage		3.135	3.3	3.465	V
I_{DD}	Power Supply Current	SMODE[1:0] = 01		80	100	mA
$I_{DDOA} + I_{DDOB}$	Output Supply Current ¹	SMODE[1:0] = 01		80	100	mA
I_{EE}	Power Supply Current	SMODE[1:0] = 00 (default)		110	130	mA
I_{DD}	Power Supply Current	SMODE[1:0] = 10		80	100	mA
$I_{DDOA} + I_{DDOB}$	Output Power Supply Current ²	SMODE[1:0] = 10		50	60	mA

NOTE 1. Differential outputs are terminated with 100Ω.

NOTE 2. Differential outputs are running at 250MHz and floating.

Table 4B. Power Supply DC Characteristics, $V_{DD} = 3.3V \pm 5\%$, $V_{DDOA} = V_{DDOB} = V_{DDOREF} = 2.5V \pm 5\%$, $GND = 0V$, $T_A = -40^\circ C$ to $85^\circ C$

Symbol	Parameter	Test Conditions	Minimum	Typical	Maximum	Units
V_{DD}	Power Supply Voltage		3.135	3.3	3.465	V
V_{DDOA} , V_{DDOB} , V_{DDOREF}	Output Supply Voltage		2.375	2.5	2.625	V
I_{DD}	Power Supply Current	SMODE[1:0] = 01		80	100	mA
$I_{DDOA} + I_{DDOB}$	Output Supply Current ¹	SMODE[1:0] = 01		80	100	mA
I_{EE}	Power Supply Current	SMODE[1:0] = 00 (default)		110	130	mA
I_{DD}	Power Supply Current	SMODE[1:0] = 10		80	100	mA
$I_{DDOA} + I_{DDOB}$	Output Power Supply Current ²	SMODE[1:0] = 10		40	50	mA

NOTE 1. Differential outputs are terminated with 100Ω.

NOTE 2. Differential outputs are running at 250MHz and floating.

Table 4C. Power Supply DC Characteristics, $V_{DD} = V_{DDOA} = V_{DDOB} = V_{DDOREF} = 2.5V \pm 5\%$, $GND = 0V$, $T_A = -40^\circ C$ to $85^\circ C$

Symbol	Parameter	Test Conditions	Minimum	Typical	Maximum	Units
V_{DD}	Power Supply Voltage		2.375	2.5	2.625	V
V_{DDOA} , V_{DDOB} , V_{DDOREF}	Output Supply Voltage		2.375	2.5	2.625	V
I_{DD}	Power Supply Current	SMODE[1:0] = 01		70	85	mA
$I_{DDOA} + I_{DDOB}$	Output Supply Current ¹	SMODE[1:0] = 01		80	95	mA
I_{EE}	Power Supply Current	SMODE[1:0] = 00 (default)		95	115	mA
I_{DD}	Power Supply Current	SMODE[1:0] = 10		70	80	mA
$I_{DDOA} + I_{DDOB}$	Output Power Supply Current ²	SMODE[1:0] = 10		40	50	mA

NOTE 1. Differential outputs are terminated with 100Ω.

NOTE 2. Differential outputs are running at 250MHz and floating.

Table 4D. LVC MOS/LVTTL DC Characteristics,
 $V_{DD} = 3.3V \pm 5\%$, $2.5V \pm 5\%$, $V_{DDOREF} = 3.3V \pm 5\%$ or $2.5V \pm 5\%$, $GND = 0V$, $T_A = -40^\circ C$ to $85^\circ C$

Symbol	Parameter		Test Conditions	Minimum	Typical	Maximum	Units
V_{IH}	Input High Voltage	OE_SE, SMODE[1:0], REF_SEL[1:0]	$V_{DD} = 3.3V \pm 5\%$	2		$V_{DD} + 0.3$	V
			$V_{DD} = 2.5V \pm 5\%$	1.7		$V_{DD} + 0.3$	V
V_{IL}	Input Low Voltage	OE_SE, SMODE[1:0], REF_SEL[1:0]	$V_{DD} = 3.3V \pm 5\%$	-0.3		0.8	V
			$V_{DD} = 2.5V \pm 5\%$	-0.3		0.7	V
I_{IH}	Input High Current	OE_SE, SMODE[1:0], REF_SEL[1:0]	$V_{DD} = V_{IN} = 3.465V$ or $2.625V$			150	μA
I_{IL}	Input Low Current	OE_SE, SMODE[1:0], REF_SEL[1:0]	$V_{DD} = 3.465V$ or $2.625V$, $V_{IN} = 0V$	-5			μA
V_{OH}	Output High Voltage	REFOUT	$V_{DDOREF} = 3.3V \pm 5\%$: $I_{OH} = -1mA$	2.6			V
			$V_{DDOREF} = 2.5V \pm 5\%$: $I_{OH} = -1mA$	1.8			V
V_{OL}	Output Low Voltage	REFOUT	$V_{DDOREF} = 3.3V \pm 5\%$ or $2.5V \pm 5\%$: $I_{OL} = 1mA$			0.5	V

Table 4E. Differential DC Characteristics, $V_{DD} = 3.3V \pm 5\%$ or $2.5V \pm 5\%$, $GND = 0V$, $T_A = -40^\circ C$ to $85^\circ C$

Symbol	Parameter		Test Conditions	Minimum	Typical	Maximum	Units
I_{IH}	Input High Current	CLK[1:0], nCLK[1:0]	$V_{DD} = V_{IN} = 3.465V$ or $2.625V$			150	μA
I_{IL}	Input Low Current	CLK[1:0], nCLK[1:0]	$V_{DD} = 3.465V$ or $2.625V$, $V_{IN} = 0V$	-150			μA
V_{PP}	Peak-to-Peak Input Voltage ¹			0.240		1.3	V
V_{CMR}	Common Mode Input Voltage ^{1, 2}			$GND + 0.5$		$V_{DD} - 0.85$	V

 NOTE 1. Input voltage should not be less than $-0.3V$ and greater than V_{DD} .

NOTE 2. Common mode voltage is defined as the crosspoint.

Table 4F. LVPECL DC Characteristics, $V_{DDOA} = V_{DDOB} = 3.3V \pm 5\%$, GND = 0V, $T_A = -40^\circ\text{C}$ to 85°C ¹

Symbol	Parameter	Test Conditions	Minimum	Typical	Maximum	Units
V_{OH}	Output High Voltage ²		$V_{DDOX} - 1.4$		$V_{DDOX} - 0.8$	V
V_{OL}	Output Low Voltage ²		$V_{DDOX} - 2.0$		$V_{DDOX} - 1.6$	V
V_{SWING}	Peak-to-Peak Output Voltage Swing		0.6		1.0	V

NOTE 1. V_{DDOX} denotes V_{DDOA} and V_{DDOB} .

NOTE 2. Outputs terminated with 50Ω to $V_{DDOX} - 2V$.

Table 4G. LVPECL DC Characteristics, $V_{DDOA} = V_{DDOB} = 2.5V \pm 5\%$, GND = 0V, $T_A = -40^\circ\text{C}$ to 85°C ¹

Symbol	Parameter	Test Conditions	Minimum	Typical	Maximum	Units
V_{OH}	Output High Voltage ²		$V_{DDOX} - 1.4$		$V_{DDOX} - 0.8$	V
V_{OL}	Output Low Voltage ²		$V_{DDOX} - 2.0$		$V_{DDOX} - 1.6$	V
V_{SWING}	Peak-to-Peak Output Voltage Swing		0.4		1.0	V

NOTE 1. V_{DDOX} denotes V_{DDOA} and V_{DDOB} .

NOTE 2. Outputs terminated with 50Ω to $V_{DDOX} - 2V$.

Table 4H. LVDS DC Characteristics, $V_{DDOA} = V_{DDOB} = 3.3V \pm 5\%$, GND = 0V, $T_A = -40^\circ\text{C}$ to 85°C

Symbol	Parameter	Test Conditions	Minimum	Typical	Maximum	Units
V_{OD}	Differential Output Voltage		247		454	mV
ΔV_{OD}	V_{OD} Magnitude Change			50		mV
V_{OS}	Offset Voltage		1.025		1.375	V
ΔV_{OS}	V_{OS} Magnitude Change			50		mV

Table 4I. LVDS DC Characteristics, $V_{DDOA} = V_{DDOB} = 2.5V \pm 5\%$, GND = 0V, $T_A = -40^\circ\text{C}$ to 85°C

Symbol	Parameter	Test Conditions	Minimum	Typical	Maximum	Units
V_{OD}	Differential Output Voltage		247		454	mV
ΔV_{OD}	V_{OD} Magnitude Change			50		mV
V_{OS}	Offset Voltage		1.025		1.375	V
ΔV_{OS}	V_{OS} Magnitude Change			50		mV

Table 5. Crystal Characteristics

Parameter	Test Conditions	Minimum	Typical	Maximum	Units
Mode of Oscillation		Fundamental			
Frequency		10		40	MHz
Equivalent Series Resistance (ESR)				50	Ω
Shunt Capacitance				7	pF
Capacitive Loading (C_L)			12	18	pF

AC Electrical Characteristics

Table 4: AC Characteristics, $V_{DD} = V_{DDOA} = V_{DDOB} = V_{DDOREF} = 3.3V \pm 5\%$, $GND = 0V$, $T_A = -40^\circ C$ to $85^\circ C$ ^{1, 2}

Symbol	Parameter		Test Conditions	Minimum	Typical	Maximum	Units
f_{OUT}	Output Frequency	LVDS, LVPECL Outputs				2000	MHz
		HCSL Outputs				250	MHz
		REFOUT				250	MHz
t_{jit}	Buffer Additive Phase Jitter, RMS: Integration Range 12kHz - 20MHz REF_SEL[1:0] = 00 or 01		Clock Frequency = 156.25MHz; Input Clock from 8T49NS010, Input Clock Jitter = 86.6fs; SMODEA/B[1:0] = 00		34.7		fs
NF	Noise Floor	LVPECL Outputs	Offset Freq. >10MHz; 156.25MHz Clock Freq.		-159.1		dBc/Hz
		LVDS Outputs			-157.0		dBc/Hz
		HCSL Outputs			-156.0		dBc/Hz
$t_{jit}(\emptyset)$	RMS Phase Jitter; 25MHz Integration Range: 100Hz - 1MHz		REF_SEL[1:0] = 10 or 11 ³		0.176		ps
t_{PD}	Propagation Delay ⁴	CLK0, nCLK0 or CLK1, nCLK1 to any Qx, nQx Outputs	SMODEA/B[1:0] = 00	0.28		0.75	ns
			SMODEA/B[1:0] = 01	0.28		0.75	ns
			SMODEA/B[1:0] = 10	0.90		2.65	ns
$t_{sk(o)}$	Output Skew ^{5, 6}					80	ps
$t_{sk(pp)}$	Part-to-Part Skew ^{6, 7}				200		ps
V_{OH}	Voltage High ^{8, 9}	HCSL Outputs	$T_A = 25^\circ C$, DC Measurement, $R_T = 50\Omega$ to GND $C_L \leq 5pF$	520		920	mV
V_{OL}	Voltage Low ^{8, 10}	HCSL Outputs		-150		+150	mV
V_{CROSS}	Absolute Crossing Voltage ^{8, 11, 12}	HCSL Outputs	$R_T = 50\Omega$ to GND $C_L \leq 5pF$	160		460	mV
ΔV_{CROSS}	Total Variation of V_{CROSS} over all Edges ^{8, 11, 13}	HCSL Outputs				140	mV
	Rise/Fall Edge Rate ^{3, 14, 15}	HCSL Outputs		0.6		4.0	V/ns
t_R / t_F	Output Rise/Fall Time	LVPECL Outputs	20% to 80%		150	300	ps
		LVDS Outputs	20% to 80%		150	300	ps
		HCSL Outputs	20% to 80%		400	750	ps
		REFOUT	20% to 80%		450	750	ps
odc	Output Duty Cycle ¹⁶	with Crystal Input		45		55	%
		with External 50%/ 50% Duty Cycle Clock Input		45		55	%
MUX_ISOLATION	MUX Isolation		156.25MHz		75		dB

NOTE 1. Electrical parameters are guaranteed over the specified ambient operating temperature range, which is established when the device is mounted in a test socket with maintained transverse airflow greater than 500 lfm. The device will meet specifications after thermal equilibrium has been reached under these conditions.

NOTE 2. All LVDS and LVPECL parameters characterized up to 1.5GHz. HCSL parameters characterized up to 250MHz.

NOTE 3. Measurement taken from differential waveform.

NOTE 4. Measured from the differential input crosspoint to the differential output crosspoint.

NOTE 5. Defined as skew between outputs at the same supply voltage and with equal load conditions. Measured at the differential crosspoint.

NOTE 6. This parameter is defined in accordance with JEDEC Standard 65.

NOTE 7. Defined as skew between outputs on different devices operating at the same supply voltage, same temperature, same frequency and with equal load conditions. Using the same type of inputs on each device, the outputs are measured at the differential crosspoint.

NOTE 8. Measurement taken from single-ended waveform.

NOTE 9. Defined as the maximum instantaneous voltage including overshoot.

NOTE 10. Defined as the minimum instantaneous voltage including undershoot.

NOTE 11. Measured at crosspoint where the instantaneous voltage value of the rising edge of Qx equals the falling edge of nQx.

NOTE 12. Refers to the total variation from the lowest crosspoint to the highest, regardless of which edge is crossing. Refers to all crosspoint for this measurement.

NOTE 13. Defined as the total variation of all crossing voltages of rising Qx and falling nQx, This is the maximum allowed variance in Vcross for any particular system.

NOTE 14. Measured from -150mV to +150mV on the differential waveform (Qx minus nQx). The signal must be monotonic through the measurement region for rise and fall time. The 300mV measurement window is centered on the differential zero crossing.

NOTE 15. Measured at 100MHz.

NOTE 16. Measured for the following frequencies: 25MHz, 100MHz, 125MHz, 156.25MHz, 312.5MHz, 400MHz, and 644.5313MHz.

Table 5: AC Characteristics, $V_{DD} = 3.3V \pm 5\%$, $V_{DDOA} = V_{DDOB} = V_{DDOREF} = 2.5V \pm 5\%$, $GND = 0V$, $T_A = -40^\circ C$ to $85^\circ C$ ^{1, 2}

Symbol	Parameter		Test Conditions	Minimum	Typical	Maximum	Units
f_{OUT}	Output Frequency	LVDS, LVPECL Outputs				2000	MHz
		HCSL Outputs				250	MHz
		REFOUT				250	MHz
t_{jit}	Buffer Additive Phase Jitter, RMS: Integration Range 12kHz - 20MHz REF_SEL[1:0] = 00 or 01		Clock Frequency = 156.25MHz; Input Clock from 8T49NS010, Input Clock Jitter = 86.8fs; SMODEA/B[1:0] = 00		36.7		fs
NF	Noise Floor	LVPECL	Offset Freq. >10MHz; 156.25MHz Clock Freq.		-159.1		dBc/Hz
		LVDS			-157.0		dBc/Hz
		HCSL			-155.7		dBc/Hz
$t_{jit}(\emptyset)$	RMS Phase Jitter; 25MHz Integration Range: 100Hz - 1MHz		REF_SEL[1:0] = 10 or 11 ³		0.191		ps
t_{PD}	Propagation Delay ⁴	CLK0, nCLK0 or CLK1, nCLK1 to any Qx, nQx Outputs	SMODEA/B[1:0] = 00	0.225		0.80	ns
			SMODEA/B[1:0] = 01	0.275		0.80	ns
			SMODEA/B[1:0] = 10	0.9		2.80	ns
$t_{sk(o)}$	Output Skew ^{5, 6}					80	ps
$t_{sk(pp)}$	Part-to-Part Skew ^{6, 7}				200		ps
V_{OH}	Voltage High ^{8, 9}	HCSL Outputs	$T_A = 25^\circ C$, DC Measurement, $R_T = 50\Omega$ to GND $C_L \leq 5pF$	520		920	mV
V_{OL}	Voltage Low ^{8, 10}	HCSL Outputs		-150		+150	mV
V_{CROSS}	Absolute Crossing Voltage ^{8, 11, 12}	HCSL Outputs	$R_T = 50\Omega$ to GND $C_L \leq 5pF$	160		460	mV
ΔV_{CROSS}	Total Variation of V_{CROSS} over all Edges ^{8, 11, 13}	HCSL Outputs				140	mV
	Rise/Fall Edge Rate ^{3, 14, 15}	HCSL Outputs		0.6		4.0	V/ns
t_R / t_F	Output Rise/Fall Time	LVPECL Outputs	20% to 80%		150	300	ps
		LVDS Outputs	20% to 80%		150	300	ps
		HCSL Outputs	20% to 80%		400	650	ps
		REFOUT	20% to 80%		450	750	ps
odc	Output Duty Cycle ¹⁶	with Crystal Input		45		55	%
		with external 50%/ 50% Duty Cycle Clock Input		45		55	%
MUX_ISOLATION	MUX Isolation	156.25MHz			75		dB

NOTE 1. Electrical parameters are guaranteed over the specified ambient operating temperature range, which is established when the device is mounted in a test socket with maintained transverse airflow greater than 500 lfm. The device will meet specifications after thermal equilibrium has been reached under these conditions.

NOTE 2. All LVDS and LVPECL parameters characterized up to 1.5GHz. HCSL parameters characterized up to 250MHz.

NOTE 3. Measurement taken from differential waveform.

NOTE 4. Measured from the differential input crosspoint to the differential output crosspoint.

NOTE 5. Defined as skew between outputs at the same supply voltage and with equal load conditions. Measured at the differential cross-point.

NOTE 6. This parameter is defined in accordance with JEDEC Standard 65.

NOTE 7. Defined as skew between outputs on different devices operating at the same supply voltage, same temperature, same frequency and with equal load conditions. Using the same type of inputs on each device, the outputs are measured at the differential cross-point.

NOTE 8. Measurement taken from single-ended waveform.

NOTE 9. Defined as the maximum instantaneous voltage including overshoot.

NOTE 10. Defined as the minimum instantaneous voltage including undershoot.

NOTE 11. Measured at crosspoint where the instantaneous voltage value of the rising edge of Qx equals the falling edge of nQx.

NOTE 12. Refers to the total variation from the lowest crosspoint to the highest, regardless of which edge is crossing. Refers to all cross-point for this measurement.

NOTE 13. Defined as the total variation of all crossing voltages of rising Qx and falling nQx, This is the maximum allowed variance in Vcross for any particular system.

NOTE 14. Measured from -150mV to +150mV on the differential waveform (Qx minus nQx). The signal must be monotonic through the measurement region for rise and fall time. The 300mV measurement window is centered on the differential zero crossing.

NOTE 15. Measured at 100MHz.

NOTE 16. Measured for the following frequencies: 25MHz, 100MHz, 125MHz, 156.25MHz, 312.5MHz, 400MHz, and 644.5313MHz.

Table 6: AC Characteristics, $V_{DD} = V_{DDOA} = V_{DDOB} = V_{DDOREF} = 2.5V \pm 5\%$, $GND = 0V$, $T_A = -40^\circ C$ to $85^\circ C$ 1, 2

Symbol	Parameter	Test Conditions	Minimum	Typical	Maximum	Units
f_{OUT}	Output Frequency	LVDS, LVPECL Outputs			2000	MHz
		HCSL Outputs			250	MHz
		REFOUT			250	MHz
t_{jit}	Buffer Additive Phase Jitter, RMS: Integration Range 12kHz - 20MHz REF_SEL[1:0] = 00 or 01	Clock Frequency = 156.25MHz; Input Clock from 8T49NS010, Input Clock Jitter = 86.8fs; SMODEA/B[1:0] = 00		37.1		fs
$t_{jit}(\emptyset)$	RMS Phase Jitter; 25MHz Integration Range: 100Hz - 1MHz	REF_SEL[1:0] = 10 or 11 ³		0.371		ps
NF	Noise Floor	LVPECL	Offset Freq. >10MHz; 156.25MHz Clock Freq.		-159	dBc/Hz
		LVDS			-157	dBc/Hz
		HCSL			-155	dBc/Hz
t_{PD}	Propagation Delay ⁴	CLK0, nCLK0 or CLK1, nCLK1 to any Qx, nQx Outputs	SMODEA/B[1:0] = 00	0.275	0.75	ns
			SMODEA/B[1:0] = 01	0.275	0.75	ns
			SMODEA/B[1:0] = 10	0.9	2.80	ns
$t_{sk(o)}$	Output Skew ^{5, 6}				80	ps
$t_{sk(pp)}$	Part-to-Part Skew ^{6, 7}			200		ps
V_{OH}	Voltage High ^{8, 9}	HCSL Outputs	$T_A = 25^\circ C$, DC Measurement, $R_T = 50\Omega$ to GND $C_L \leq 5pF$	520	920	mV
V_{OL}	Voltage Low ^{8, 10}	HCSL Outputs		-150	+150	mV
V_{CROSS}	Absolute Crossing Voltage ^{8, 11, 12}	HCSL Outputs	$R_T = 50\Omega$ to GND $C_L \leq 5pF$	160	460	mV
ΔV_{CROSS}	Total Variation of V_{CROSS} over all Edges ^{8, 11, 13}	HCSL Outputs			140	mV
	Rise/Fall Edge Rate ^{3, 14, 15}	HCSL Outputs		0.6	4.0	V/ns
t_R / t_F	Output Rise/Fall Time	LVPECL Outputs	20% to 80%	150	300	ps
		LVDS Outputs	20% to 80%	150	300	ps
		HCSL Outputs	20% to 80%	400	650	ps
		REFOUT	20% to 80%	450	750	ps
odc	Output Duty Cycle ¹⁶	With Crystal Input		45	55	%
		With external 50%/ 50% Duty Cycle Clock Input		45	55	%
MUX_ISOLATION	MUX Isolation	156.25MHz		75		dB

NOTE 1. Electrical parameters are guaranteed over the specified ambient operating temperature range, which is established when the device is mounted in a test socket with maintained transverse airflow greater than 500 lfm. The device will meet specifications after thermal equilibrium has been reached under these conditions.

NOTE 2. All LVDS and LVPECL parameters characterized up to 1.5GHz. HCSL parameters characterized up to 250MHz.

NOTE 3. Measurement taken from differential waveform.

NOTE 4. Measured from the differential input crosspoint to the differential output crosspoint.

NOTE 5. Defined as skew between outputs at the same supply voltage and with equal load conditions. Measured at the differential crosspoint.

NOTE 6. This parameter is defined in accordance with JEDEC Standard 65.

NOTE 7. Defined as skew between outputs on different devices operating at the same supply voltage, same temperature, same frequency and with equal load conditions. Using the same type of inputs on each device, the outputs are measured at the differential cross-point.

NOTE 8. Measurement taken from single-ended waveform.

NOTE 9. Defined as the maximum instantaneous voltage including overshoot.

NOTE 10. Defined as the minimum instantaneous voltage including undershoot.

NOTE 11. Measured at crosspoint where the instantaneous voltage value of the rising edge of Qx equals the falling edge of nQx.

NOTE 12. Refers to the total variation from the lowest crosspoint to the highest, regardless of which edge is crossing. Refers to all cross-point for this measurement.

NOTE 13. Defined as the total variation of all crossing voltages of rising Qx and falling nQx, This is the maximum allowed variance in Vcross for any particular system.

NOTE 14. Measured from -150mV to +150mV on the differential waveform (Qx minus nQx). The signal must be monotonic through the measurement region for rise and fall time. The 300mV measurement window is centered on the differential zero crossing.

NOTE 15. Measured at 100MHz.

NOTE 16. Measured for the following frequencies: 25MHz, 100MHz, 125MHz, 156.25MHz, 312.5MHz, 400MHz, and 644.5313MHz.

Additive Phase Jitter

The spectral purity in a band at a specific offset from the fundamental compared to the power of the fundamental is called the **dBc Phase Noise**. This value is normally expressed using a Phase noise plot and is most often the specified plot in many applications. Phase noise is defined as the ratio of the noise power present in a 1Hz band at a specified offset from the fundamental frequency to the power value of the fundamental. This ratio is expressed in decibels (dBm) or a ratio

of the power in the 1Hz band to the power in the fundamental. When the required offset is specified, the phase noise is called a **dBc** value, which simply means dBm at a specified offset from the fundamental. By investigating jitter in the frequency domain, we get a better understanding of its effects on the desired application over the entire time record of the signal. It is mathematically possible to calculate an expected bit error rate given a phase noise plot.

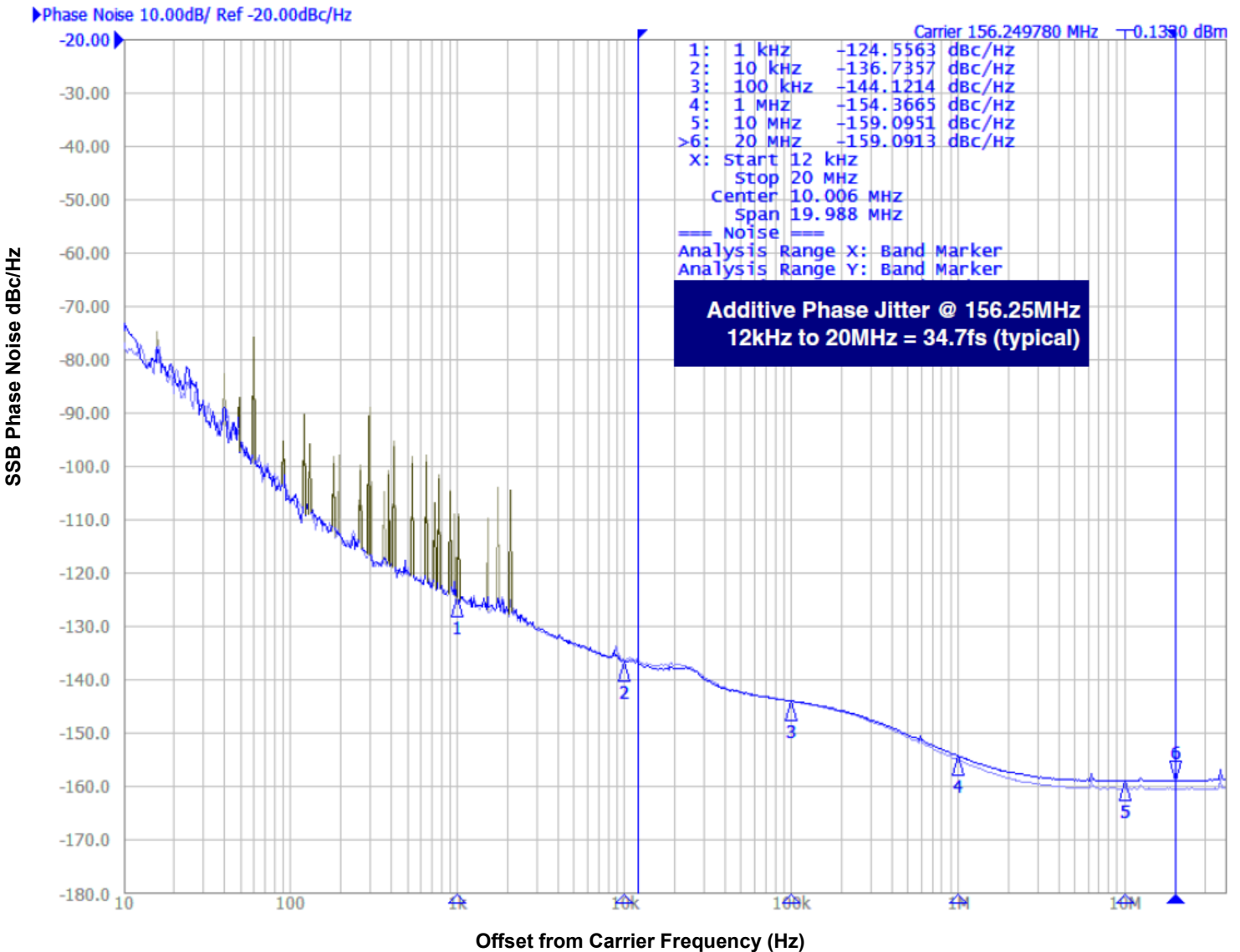

As with most timing specifications, phase noise measurements have issues relating to the limitations of the measurement equipment. The noise floor of the equipment can be higher or lower than the noise floor of the device. Additive phase noise is dependent on both the noise floor of the input source and measurement equipment.

The additive phase jitter for this device was measured using an IDT Clock Driver 8T49NS010 as an input source and Agilent E5052 phase noise analyzer.

Applications Information

Recommendations for Unused Input and Output Pins

Inputs:

CLK/nCLK⁻ Inputs

For applications not requiring the use of the differential input, both CLK and nCLK can be left floating. Though not required, but for additional protection, 1kΩ resistors can be tied from CLK to ground and nCLK to V_{DD}.

Crystal Inputs

For applications not requiring the use of the crystal oscillator input, both XTAL_IN and XTAL_OUT can be left floating. Though not required, but for additional protection, a 1kΩ resistor can be tied from XTAL_IN to ground.

LVC MOS Control Pins

All control pins have internal pulldowns; additional resistance is not required but can be added for additional protection. A 1kΩ resistor can be used.

Crystal Input Interface

The 8T39S04A has been characterized with 18pF parallel resonant crystals. The capacitor values, C1 and C2, shown in *Figure 1* below were determined using an 18pF parallel resonant crystal and were chosen to minimize the ppm error. In addition, the recommended 12pF parallel resonant crystal tuning is shown in *Figure 2*. The optimum C1 and C2 values can be slightly adjusted for different board layouts.

Power Up Ramp Sequence

This device has multiple supply pins dedicated for different blocks. Output power supplies V_{DDOx} (V_{DDOA}, V_{DDOB}, V_{DDOREF}) must ramp up before, or concurrently with core power supply V_{DD}. All power supplies must ramp up in a linear fashion and monotonically. Both V_{DDOA} and V_{DDOB} power supplies must be powered-up even when only one bank of outputs is in use.

Outputs:

LVC MOS Output (REFOUT)

If LVC MOS output is not used, then disable the output and it can be left floating.

LVPECL and HCSL Outputs

All unused output pairs can be left floating. We recommend that there is no trace attached.

LVDS Outputs

All unused LVDS output pairs can be either left floating or terminated with 100Ω across. If they are left floating, we recommend that there is no trace attached.

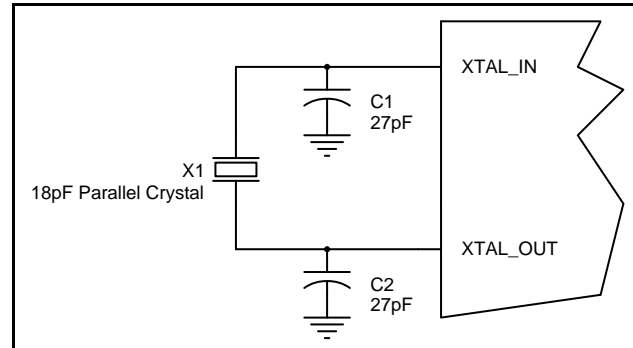

Figure 1. Crystal Input Interface

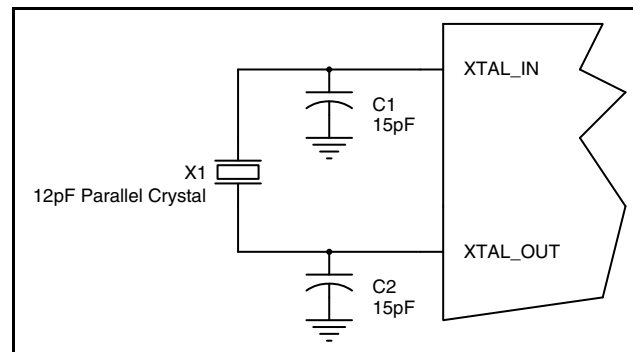

Figure 2. Crystal Input Interface

Overdriving the XTAL Interface

The XTAL_IN input can be overdriven by an LVCMOS driver or by one side of a differential driver through an AC coupling capacitor. The XTAL_OUT pin can be left floating. The amplitude of the input signal should be between 500mV and 1.8V and the slew rate should not be less than 0.2V/ns. For 3.3V LVCMOS inputs, the amplitude must be reduced from full swing to at least half the swing in order to prevent signal interference with the power rail and to reduce internal noise. *Figure 3A* shows an example of the interface diagram for a high speed 3.3V LVCMOS driver. This configuration requires that the sum of the output impedance of the driver (R_o) and the series resistance (R_s) equals the transmission line impedance. In addition, matched termination at the crystal input will attenuate the signal in half. This

can be done in one of two ways. First, R_1 and R_2 in parallel should equal the transmission line impedance. For most 50Ω applications, R_1 and R_2 can be 100Ω. This can also be accomplished by removing R_1 and changing R_2 to 50Ω. The values of the resistors can be increased to reduce the loading for a slower and weaker LVCMOS driver. *Figure 3B* shows an example of the interface diagram for an LVPECL driver. This is a standard LVPECL termination with one side of the driver feeding the XTAL_IN input. It is recommended that all components in the schematics be placed in the layout. Though some components might not be used, they can be utilized for debugging purposes. The datasheet specifications are characterized and guaranteed by using a quartz crystal as the input.

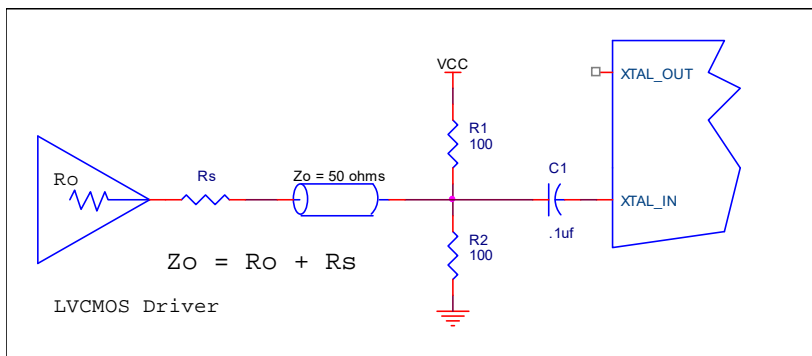

Figure 3A. General Diagram for LVCMOS Driver to XTAL Input Interface

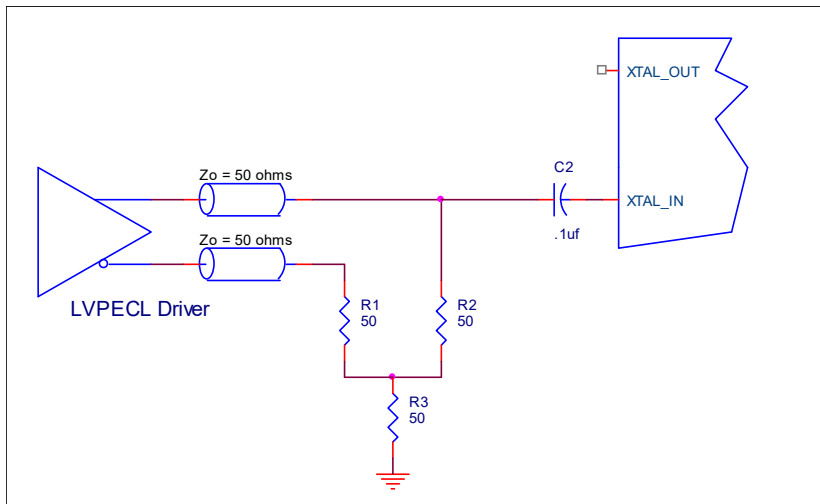

Figure 3B. General Diagram for LVPECL Driver to XTAL Input Interface

Wiring the Differential Input to Accept Single-Ended Levels

Figure 4 shows how a differential input can be wired to accept single ended levels. The reference voltage $V_1 = V_{DD}/2$ is generated by the bias resistors R1 and R2. The bypass capacitor (C1) is used to help filter noise on the DC bias. This bias circuit should be located as close to the input pin as possible. The ratio of R1 and R2 might need to be adjusted to position the V_1 in the center of the input voltage swing. For example, if the input clock swing is 2.5V and $V_{DD} = 3.3V$, R1 and R2 value should be adjusted to set V_1 at 1.25V. The values below are for when both the single ended swing and V_{DD} are at the same voltage. This configuration requires that the sum of the output impedance of the driver (R_o) and the series resistance (R_s) equals the transmission line impedance. In addition, matched termination at the input will attenuate the signal in half. This can be done in one of two ways. First, R3 and R4 in parallel should equal the transmission

line impedance. For most 50Ω applications, R3 and R4 can be 100Ω. The values of the resistors can be increased to reduce the loading for slower and weaker LVCMOS driver. When using single-ended signaling, the noise rejection benefits of differential signaling are reduced. Even though the differential input can handle full rail LVCMOS signaling, it is recommended that the amplitude be reduced. The datasheet specifies a lower differential amplitude, however this only applies to differential signals. For single-ended applications, the swing can be larger, however V_{IL} cannot be less than -0.3V and V_{IH} cannot be more than $V_{DD} + 0.3V$. Though some of the recommended components might not be used, the pads should be placed in the layout. They can be utilized for debugging purposes. The datasheet specifications are characterized and guaranteed by using a differential signal.

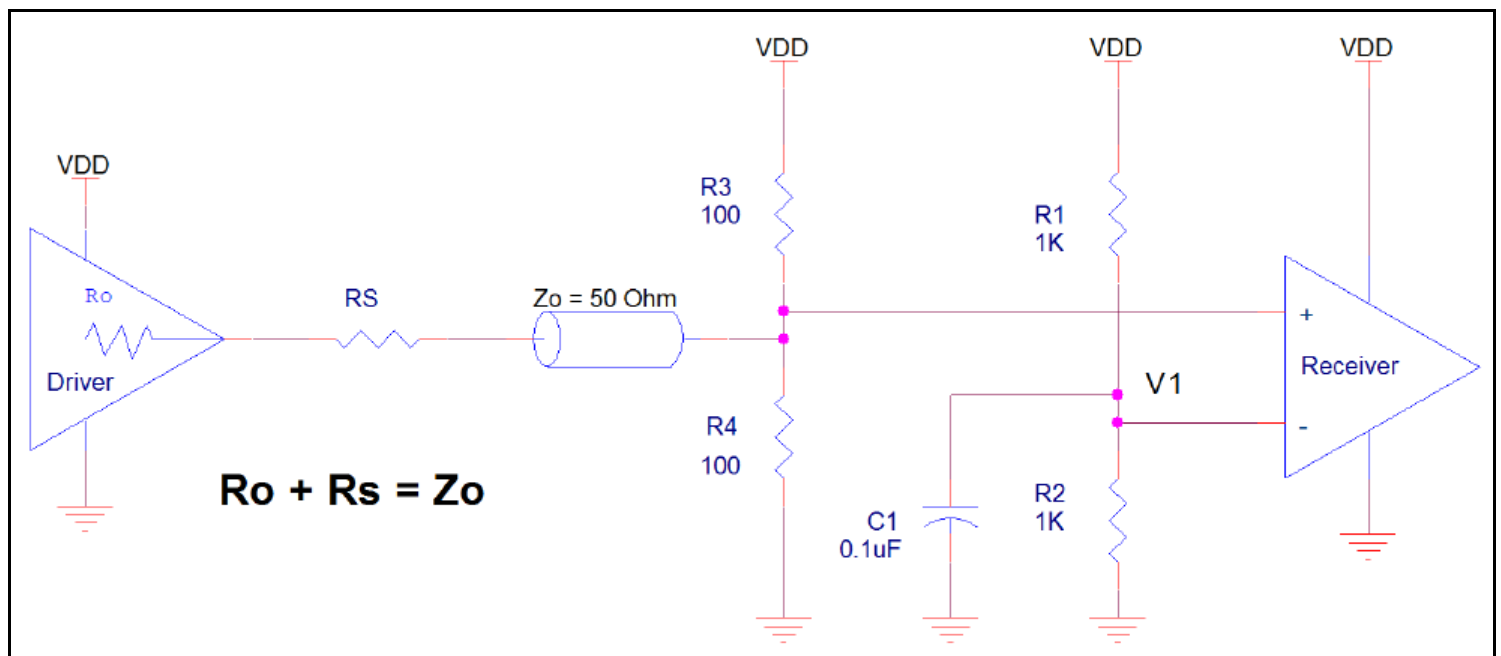

Figure 4. Recommended Schematic for Wiring a Differential Input to Accept Single-ended Levels

3.3V Differential Clock Input Interface

The CLK /nCLK accepts LVDS, LVPECL, HSTL and other differential signals. Both differential inputs must meet the V_{PP} and V_{CMR} input requirements. *Figures 5A to 5E* show interface examples for the CLK/nCLK input driven by the most common driver types. The input interfaces suggested here are examples only. Please consult with the

vendor of the driver component to confirm the driver termination requirements. For example, in Figure 5A, the input termination applies for IDT open emitter HSTL drivers. If you are using an HSTL driver from another vendor, use their termination recommendation.

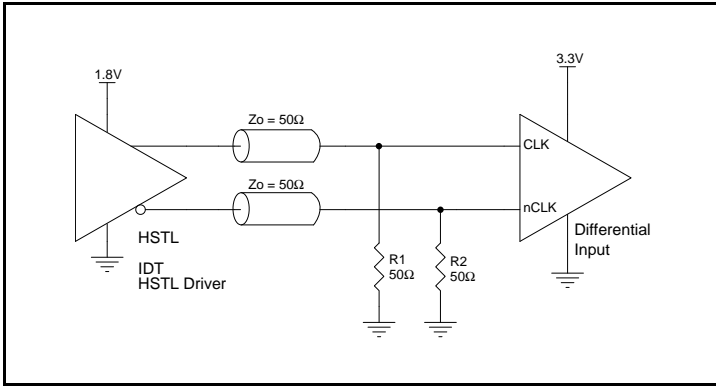

Figure 5A. CLK/nCLK Input Driven by an IDT Open Emitter HSTL Driver

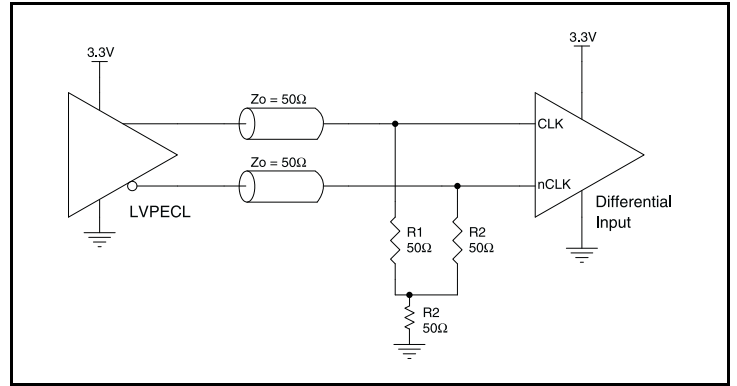

Figure 5B. CLK/nCLK Input Driven by a 3.3V LVPECL Driver

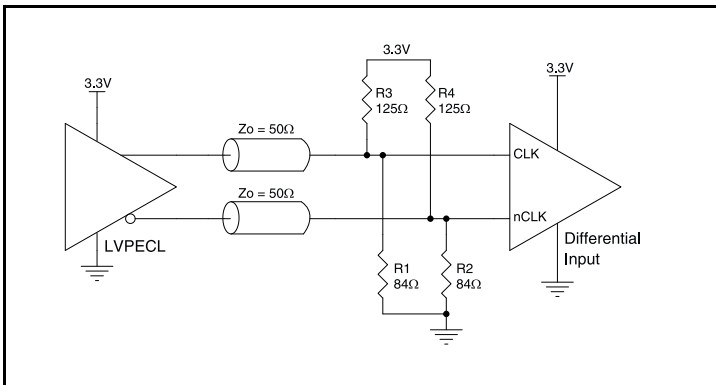

Figure 5C. CLK/nCLK Input Driven by a 3.3V LVPECL Driver

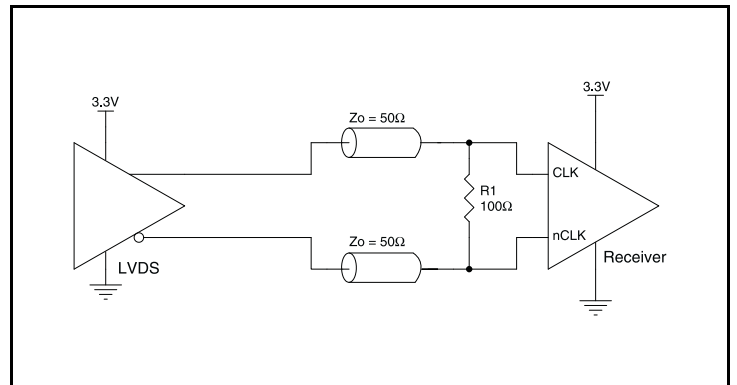

Figure 5D. CLK/nCLK Input Driven by a 3.3V LVDS Driver

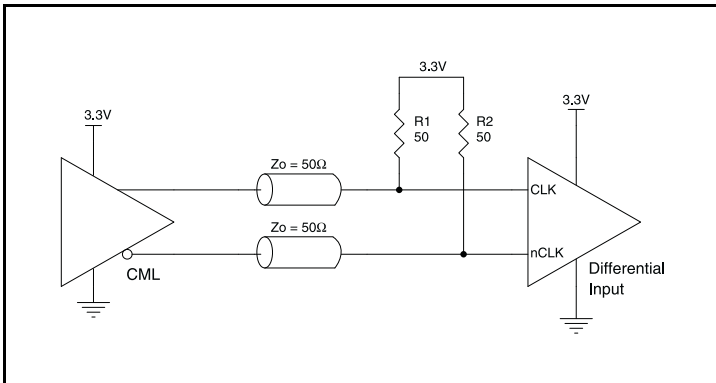

Figure 5E. CLK/nCLK Input Driven by an IDT Open Collector CML Driver

2.5V Differential Clock Input Interface

The CLK /nCLK accepts LVDS, LVPECL, HSTL, HCSSL and other differential signals. Both V_{SWING} and V_{OH} must meet the V_{PP} and V_{CMR} input requirements. Figures 6A to 6E show interface examples for the CLK/nCLK input driven by the most common driver types. The input interfaces suggested here are examples only. Please consult

with the vendor of the driver component to confirm the driver termination requirements. For example, in Figure 6A, the input termination applies for IDT open emitter HSTL drivers. If you are using an HSTL driver from another vendor, use their termination recommendation.

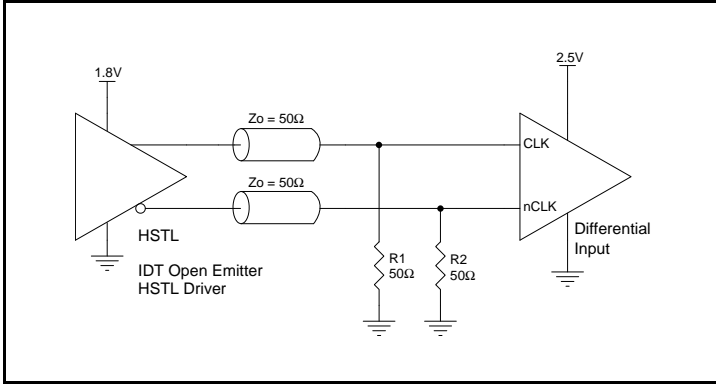

Figure 6A. CLK/nCLK Input Driven by an IDT Open Emitter HSTL Driver

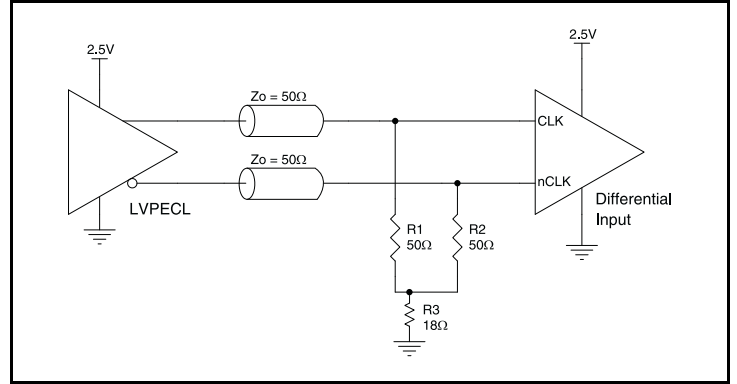

Figure 6B. CLK/nCLK Input Driven by a 2.5V LVPECL Driver

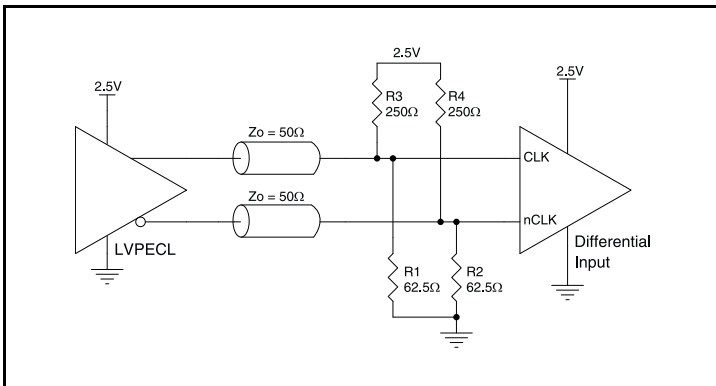

Figure 6C. CLK/nCLK Input Driven by a 2.5V LVPECL Driver

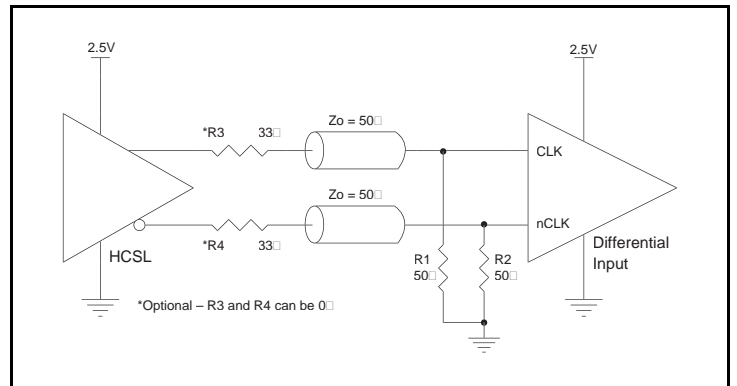

Figure 6D. CLK/nCLK Input Driven by a 2.5V HCSSL Driver

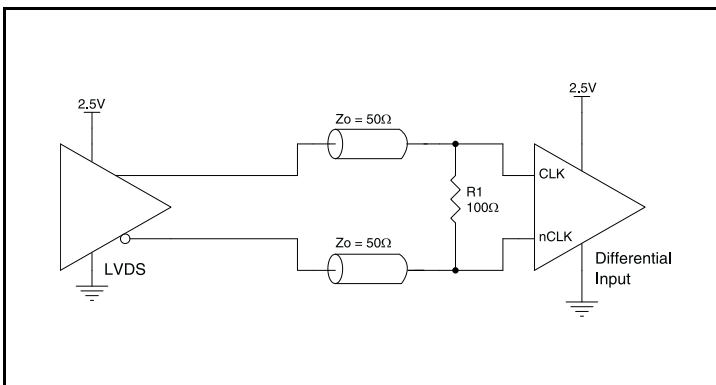
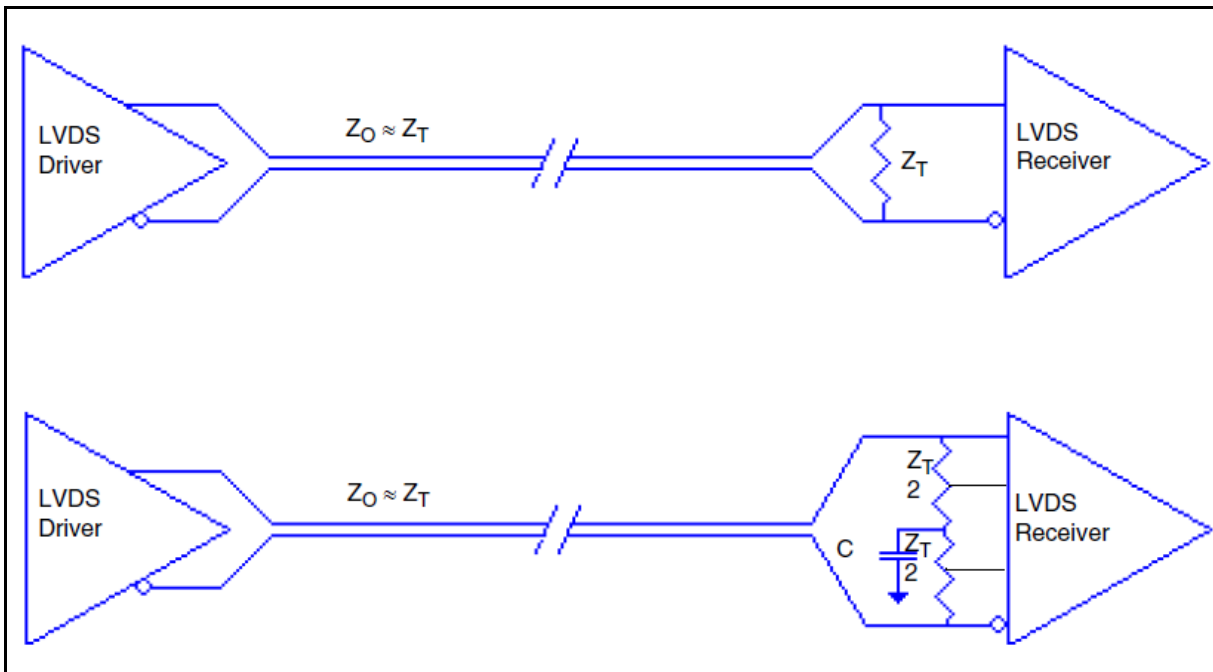

Figure 6E. CLK/nCLK Input Driven by a 2.5V LVDS Driver

LVDS Driver Termination

For a general LVDS interface, the recommended value for the termination impedance (Z_T) is between 90Ω and 132Ω . The actual value should be selected to match the differential impedance (Z_0) of your transmission line. A typical point-to-point LVDS design uses a 100Ω parallel resistor at the receiver and a 100Ω differential transmission-line environment. In order to avoid any transmission-line reflection issues, the components should be surface mounted and must be placed as close to the receiver as possible. IDT offers a full line of LVDS compliant devices with two types of output structures: current source and voltage source. The standard termination schematic as shown in *Figure 7A* can be used

with either type of output structure. *Figure 7B*, which can also be used with both output types, is an optional termination with center tap capacitance to help filter common mode noise. The capacitor value should be approximately 50pF . If using a non-standard termination, it is recommended to contact IDT and confirm if the output structure is current source or voltage source type. In addition, since these outputs are LVDS compatible, the input receiver's amplitude and common-mode input range should be verified for compatibility with the output.



LVDS Termination

Termination for 3.3V LVPECL Outputs

The clock topology shown below is a typical termination for LVPECL outputs. The two different terminations mentioned are recommended only as guidelines.

The differential outputs are low impedance follower outputs that

generate ECL/LVPECL compatible outputs. Therefore, terminating resistors (DC current path to ground) or current sources must be used for functionality. These outputs are designed to drive 50Ω transmission lines. Matched impedance techniques should be used to maximize operating frequency and minimize signal distortion.

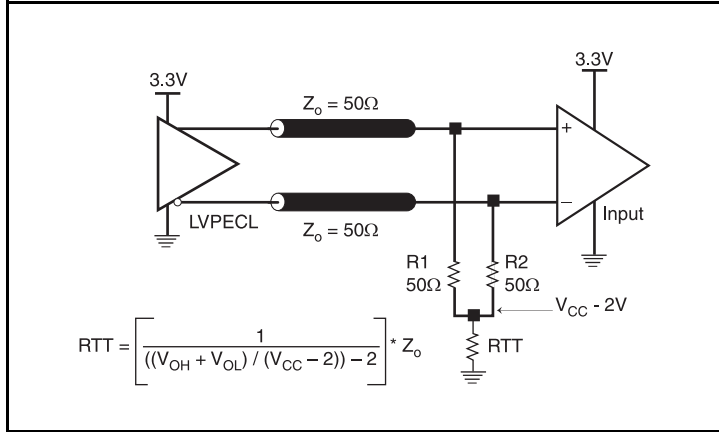

Figure 8A. 3.3V LVPECL Output Termination

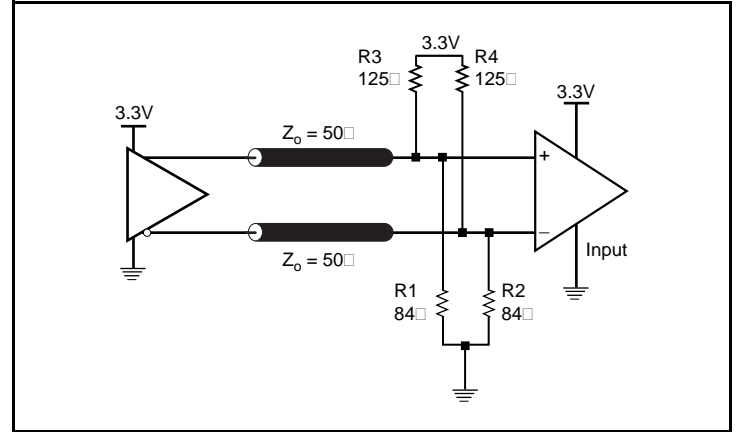

Figure 8B. 3.3V LVPECL Output Termination

Termination for 2.5V LVPECL Outputs

Figure 9A and Figure 9B show examples of termination for 2.5V LVPECL driver. These terminations are equivalent to terminating 50Ω to $V_{DDO} - 2V$. For $V_{DDO} = 2.5V$, the $V_{DDO} - 2V$ is very close to ground

level. The R3 in Figure 9B can be eliminated and the termination is shown in Figure 9C.

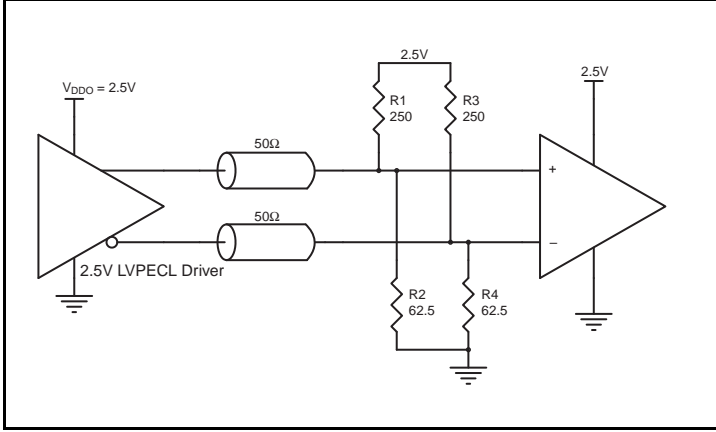

Figure 9A. 2.5V LVPECL Driver Termination Example

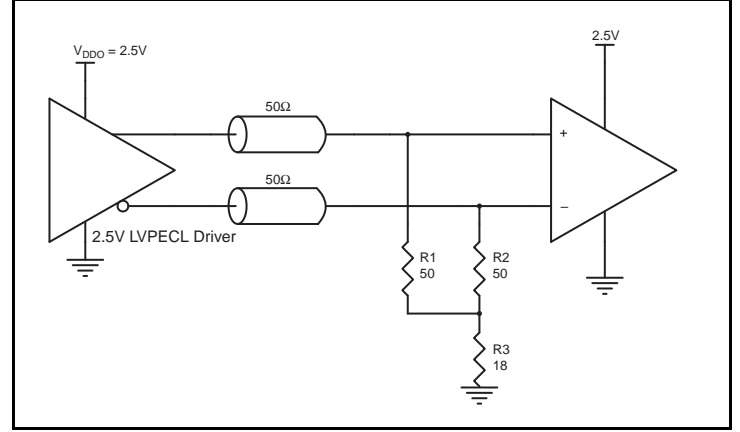

Figure 9B. 2.5V LVPECL Driver Termination Example

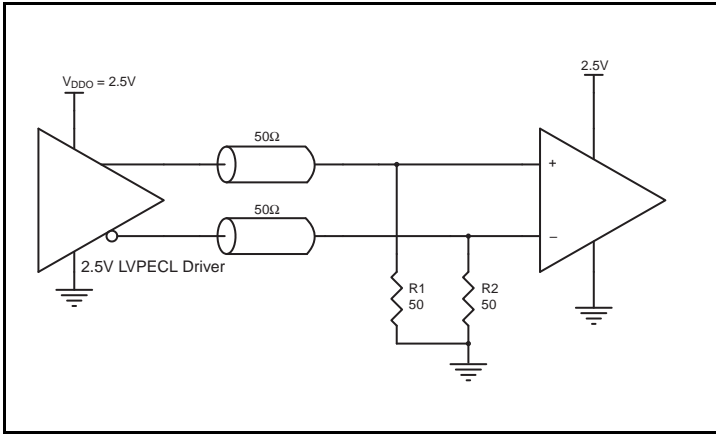

Figure 9C. 2.5V LVPECL Driver Termination Example

Recommended Termination

Figure 10A is the recommended source termination for applications where the driver and receiver will be on a separate PCBs. This termination is the standard for PCI Express™ and HCSL output

types. All traces should be 50Ω impedance single-ended or 100Ω differential.

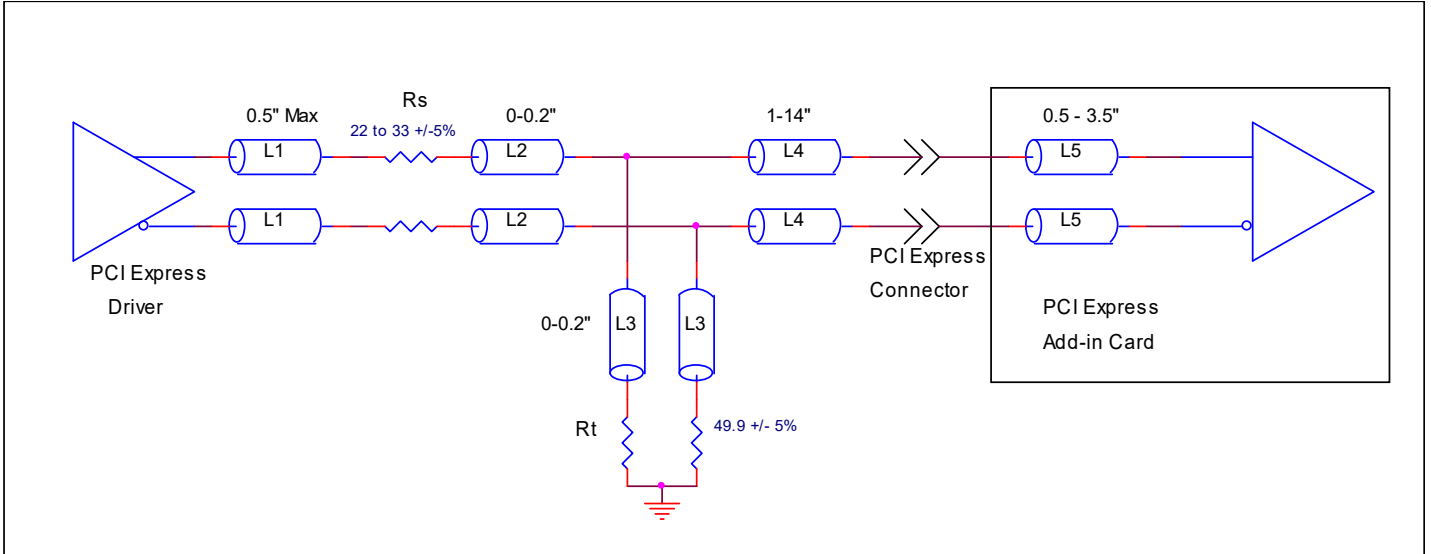

Figure 10A. Recommended Source Termination (where the driver and receiver will be on separate PCBs)

Figure 10B is the recommended termination for applications where a point-to-point connection can be used. A point-to-point connection contains both the driver and the receiver on the same PCB. With a matched termination at the receiver, transmission-line reflections will

be minimized. In addition, a series resistor (R_s) at the driver offers flexibility and can help dampen unwanted reflections. The optional resistor can range from 0Ω to 33Ω. All traces should be 50Ω impedance single-ended or 100Ω differential.

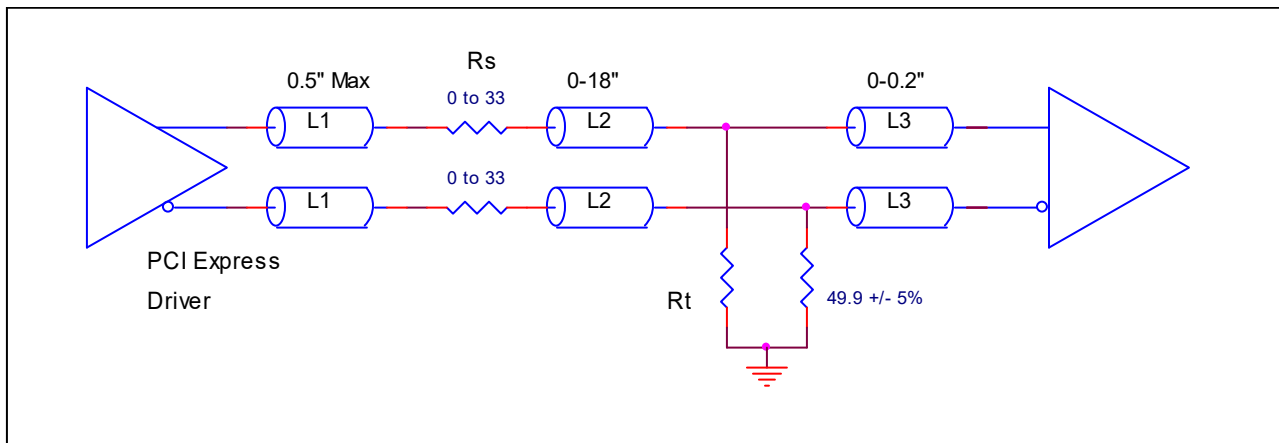

Figure 10B. Recommended Termination (where a point-to-point connection can be used)

VFQFN EPAD Thermal Release Path

In order to maximize both the removal of heat from the package and the electrical performance, a land pattern must be incorporated on the Printed Circuit Board (PCB) within the footprint of the package corresponding to the exposed metal pad or exposed heat slug on the package, as shown in *Figure 11*. The solderable area on the PCB, as defined by the solder mask, should be at least the same size/shape as the exposed pad/slug area on the package to maximize the thermal/electrical performance. Sufficient clearance should be designed on the PCB between the outer edges of the land pattern and the inner edges of pad pattern for the leads to avoid any shorts.

While the land pattern on the PCB provides a means of heat transfer and electrical grounding from the package to the board through a solder joint, thermal vias are necessary to effectively conduct from the surface of the PCB to the ground plane(s). The land pattern must be connected to ground through these vias. The vias act as “heat pipes”. The number of vias (i.e. “heat pipes”) are application specific

and dependent upon the package power dissipation as well as electrical conductivity requirements. Thus, thermal and electrical analysis and/or testing are recommended to determine the minimum number needed. Maximum thermal and electrical performance is achieved when an array of vias is incorporated in the land pattern. It is recommended to use as many vias connected to ground as possible. It is also recommended that the via diameter should be 12 to 13mils (0.30 to 0.33mm) with 1oz copper via barrel plating. This is desirable to avoid any solder wicking inside the via during the soldering process which may result in voids in solder between the exposed pad/slug and the thermal land. Precautions should be taken to eliminate any solder voids between the exposed heat slug and the land pattern. Note: These recommendations are to be used as a guideline only. For further information, please refer to the Application Note on the Surface Mount Assembly of Amkor’s Thermally/ Electrically Enhance Lead frame Base Package, Amkor Technology.

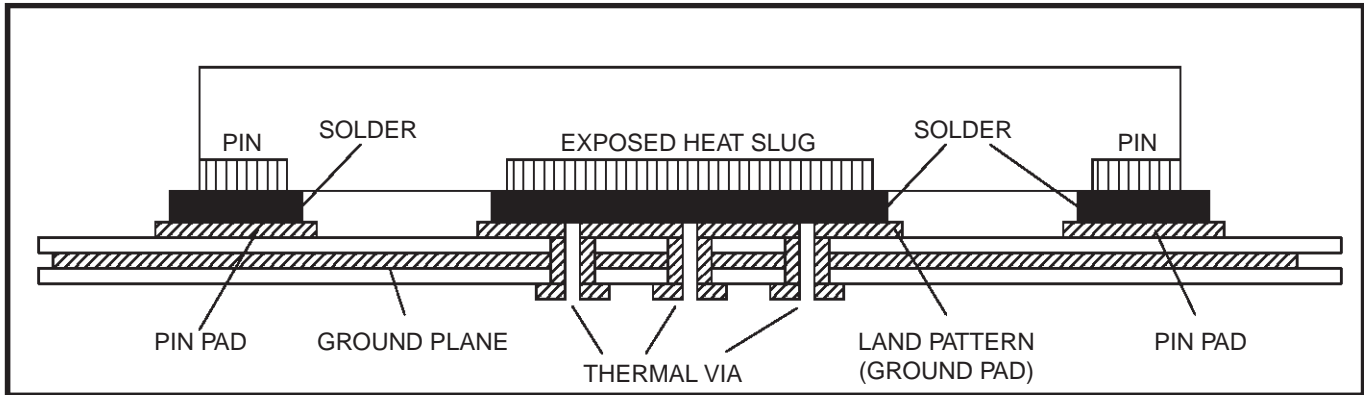

Figure 11. P.C. Assembly for Exposed Pad Thermal Release Path – Side View (drawing not to scale)

Power Considerations

This section provides information on power dissipation and junction temperature for the 8T39S04A. Equations and example calculations are also provided.

LVPECL Power Considerations

1. Power Dissipation.

The total power dissipation for the 8T39S04A is the sum of the core power plus the power dissipated due to outputs switching. The following is the power dissipation for $V_{DD} = 3.3V + 5\% = 3.465V$, which gives worst case results.

The Maximum current at 85°C is as follows:

$$I_{EE_MAX} = 130mA.$$

- Power (core)_{MAX} = $I_{EE_MAX} * V_{DD_MAX} = 3.465V * 130mA = \mathbf{450.45mW}$
- Power (outputs)_{MAX} = **30mW/Loaded Output pair**

If all outputs are loaded, the total power is $4 * 32mW = \mathbf{128mW}$

$$\text{Max LVPECL Power Dissipation} = 450.45mW + 128mW = \mathbf{578.45mW}$$

LVC MOS Output Power Dissipation

- Static Power Dissipation:
Power (static)_{MAX} = $V_{DDREF_MAX} * I_{DDREF_MAX} = 3.465V * 2mA = \mathbf{6.93mW}$
($I_{DDREF_MAX} = 2mA$)
- Dynamic Power Dissipation at 250MHz:
Power (Dynamic)_{MAX} = $C_{PD} * F_{MAX} * N * V_{DDOREF}^2 = 5.3pF * 250MHz * 1 * 3.465^2 = \mathbf{15.9mW}$
- LVC MOS Power Dissipation = $6.93mW + 15.9mW = \mathbf{22.84mW}$

$$\text{Total Power Dissipation} = 578.45mW + 22.84mW = \mathbf{601mW}$$

2. Junction Temperature.

Junction temperature, T_j , is the temperature at the junction of the bond wire and bond pad directly affects the reliability of the device. The maximum recommended junction temperature is 125°C. Limiting the internal transistor junction temperature, T_j , to 125°C ensures that the bond wire and bond pad temperature remains below 125°C.

The equation for T_j is as follows: $T_j = \theta_{JA} * Pd_total + T_A$

T_j = Junction Temperature

θ_{JA} = Junction-to-Ambient Thermal Resistance

Pd_total = Total Device Power Dissipation (example calculation is in section 1 above)

T_A = Ambient Temperature

In order to calculate junction temperature, the appropriate junction-to-ambient thermal resistance θ_{JA} must be used. Assuming no air flow and a multi-layer board, the appropriate value is 39.5°C/W per Table 7 below. Therefore, T_j for an ambient temperature of 85°C with all outputs switching is:

$$85^\circ C + 0.601W * 39.5^\circ C/W = 108.7^\circ C. \text{ This is below the limit of } 125^\circ C.$$

This calculation is only an example. T_j will obviously vary depending on the number of loaded outputs, supply voltage, air flow and the type of board (multi-layer).

Table 7. Thermal Resistance θ_{JA} for 32-Lead VFQFN

θ_{JA} vs. Air Flow			
Meters per Second	0	1	2.5
Multi-Layer PCB, JEDEC Standard Test Boards	39.5°C/W	34.5°C/W	31.0°C/W

3. Calculations and Equations.

The purpose of this section is to calculate the power dissipation for the LVPECL output pairs.

LVPECL output driver circuit and termination are shown in *Figure 12*.

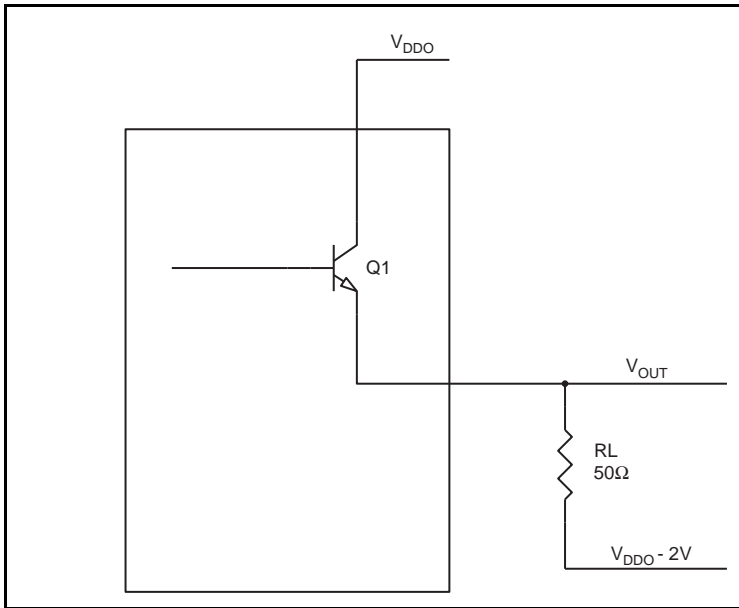

Figure 12. LVPECL Driver Circuit and Termination

To calculate power dissipation due to outputs switching, use the following equations which assume a 50Ω load, and a termination voltage of $V_{DDO} - 2V$.

- For logic high, $V_{OUT} = V_{OH_MAX} = V_{DDO_MAX} - 0.8V$
 $(V_{DDO_MAX} - V_{OH_MAX}) = 0.8V$
- For logic low, $V_{OUT} = V_{OL_MAX} = V_{DDO_MAX} - 1.6V$
 $(V_{DDO_MAX} - V_{OL_MAX}) = 1.6V$

Pd_H is power dissipation when the output drives high.

Pd_L is the power dissipation when the output drives low.

$$Pd_H = [(V_{OH_MAX} - (V_{DDO_MAX} - 2V))/R_L] * (V_{DDO_MAX} - V_{OH_MAX}) = [(2V - (V_{DDO_MAX} - V_{OH_MAX}))/R_L] * (V_{DDO_MAX} - V_{OH_MAX}) = [(2V - 0.8V)/50\Omega] * 0.8V = \mathbf{19.80mW}$$

$$Pd_L = [(V_{OL_MAX} - (V_{DDO_MAX} - 2V))/R_L] * (V_{DDO_MAX} - V_{OL_MAX}) = [(2V - (V_{DDO_MAX} - V_{OL_MAX}))/R_L] * (V_{DDO_MAX} - V_{OL_MAX}) = [(2V - 1.6V)/50\Omega] * 1.6V = \mathbf{12.8mW}$$

$$\text{Total Power Dissipation per output pair} = Pd_H + Pd_L = 32mW$$

Power Considerations

This section provides information on power dissipation and junction temperature for the 8T39S04A. Equations and example calculations are also provided.

LVDS Power Considerations

1. Power Dissipation.

The total power dissipation for the 8T39S04A is the sum of the core power plus the power dissipated due to outputs switching. The following is the power dissipation for $V_{DD} = 3.3V + 5\% = 3.465V$, which gives worst case results.

The Maximum current at 85°C is as follows:

$$I_{DD_MAX} = 95mA$$

$$I_{DDO_MAX} = 90mA$$

- Maximum LVDS Power Dissipation = $V_{DD_MAX} * (I_{DD_MAX} + I_{DDO_MAX}) = 3.465V * (95mA + 90mA) = \mathbf{641mW}$

LVC MOS Output Power Dissipation

- Static Power Dissipation:
Power (static)_{MAX} = $V_{DDOREF_MAX} * I_{DDREF_MAX} = 3.465V * 2mA = \mathbf{6.93mW}$
($I_{DDREF_MAX} = 2mA$)
- Dynamic Power Dissipation at 250MHz:
Power (Dynamic)_{MAX} = $C_{PD} * f_{MAX} * N * V_{DDOREF}^2 = 5.3pF * 250MHz * 1 * 3.465^2 = \mathbf{15.9mW}$
- LVC MOS Power Dissipation = $6.93mW + 15.9mW = \mathbf{22.84mW}$

$$\text{Total Power Dissipation} = 641mW + 22.84mW = \mathbf{663.9mW}$$

2. Junction Temperature.

Junction temperature, T_j , is the temperature at the junction of the bond wire and bond pad directly affects the reliability of the device. The maximum recommended junction temperature is 125°C. Limiting the internal transistor junction temperature, T_j , to 125°C ensures that the bond wire and bond pad temperature remains below 125°C.

The equation for T_j is as follows: $T_j = \theta_{JA} * Pd_total + T_A$

T_j = Junction Temperature

θ_{JA} = Junction-to-Ambient Thermal Resistance

Pd_total = Total Device Power Dissipation (example calculation is in section 1 above)

T_A = Ambient Temperature

In order to calculate junction temperature, the appropriate junction-to-ambient thermal resistance θ_{JA} must be used. Assuming no air flow and a multi-layer board, the appropriate value is 39.5°C/W per Table 7. Therefore, T_j for an ambient temperature of 85°C with all outputs switching is:

$$85^\circ C + 0.664W * 39.5^\circ C/W = 111.2^\circ C. \text{ This is below the limit of } 125^\circ C.$$

This calculation is only an example. T_j will obviously vary depending on the number of loaded outputs, supply voltage, air flow and the type of board (multi-layer).

Power Considerations

This section provides information on power dissipation and junction temperature for the 8T39S04A. Equations and example calculations are also provided.

HCSL Power Considerations

1. Power Dissipation.

The total power dissipation for the IDT8T39S04A is the sum of the core power plus the power dissipated due to outputs switching. The following is the power dissipation for $V_{DD} = 3.3V + 5\% = 3.465V$, which gives worst case results.

The Maximum current at 85°C is as follows:

$$I_{DD_MAX} = 95mA$$

$$I_{DDO_MAX} = 60mA \text{ (application frequency = 250MHz)}$$

- Power (core)_{MAX} = $V_{DD_MAX} * (I_{DD_MAX} + I_{DDO_MAX}) = 3.465V * (95mA + 60mA) = \mathbf{537.1mW}$
- Power (outputs)_{MAX} = **44.5mW/Loaded Output pair**

If all outputs are loaded, the total power is $4 * 44.5mW = \mathbf{178mW}$

$$\text{Max HCSL Power Dissipation} = 537.1mW + 178mW = 715.1mW$$

LVC MOS Output Power Dissipation

- Static Power Dissipation:
Power (static)_{MAX} = $V_{DDOREF_MAX} * I_{DDREF_MAX} = 3.465V * 2mA = \mathbf{6.93mW}$
($I_{DDREF_MAX} = 2mA$)
- Dynamic Power Dissipation at 250MHz:
Power (Dynamic)_{MAX} = $C_{PD} * f_{MAX} * N * V_{DDOREF}^2 = 5.3pF * 250MHz * 1 * 3.465^2 = \mathbf{15.9mW}$
- LVC MOS Power Dissipation = $6.93mW + 15.9mW = \mathbf{22.84mW}$

$$\text{Total Power Dissipation} = 715.1mW + 22.84mW = \mathbf{737.9mW}$$

2. Junction Temperature.

Junction temperature, T_j , is the temperature at the junction of the bond wire and bond pad directly affects the reliability of the device. The maximum recommended junction temperature is 125°C. Limiting the internal transistor junction temperature, T_j , to 125°C ensures that the bond wire and bond pad temperature remains below 125°C.

The equation for T_j is as follows: $T_j = \theta_{JA} * Pd_total + T_A$

T_j = Junction Temperature

θ_{JA} = Junction-to-Ambient Thermal Resistance

Pd_total = Total Device Power Dissipation (example calculation is in section 1 above)

T_A = Ambient Temperature

In order to calculate junction temperature, the appropriate junction-to-ambient thermal resistance θ_{JA} must be used. Assuming no air flow and a multi-layer board, the appropriate value is 39.5°C/W per Table 7. Therefore, T_j for an ambient temperature of 85°C with all outputs switching is:

$$85^\circ C + 0.738W * 39.5^\circ C/W = 114.1^\circ C. \text{ This is below the limit of } 125^\circ C.$$

This calculation is only an example. T_j will obviously vary depending on the number of loaded outputs, supply voltage, air flow and the type of board (multi-layer).

3. Calculations and Equations.

The purpose of this section is to calculate power dissipation on the IC per HCSL output pair.

HCSL output driver circuit and termination are shown in *Figure 13*.

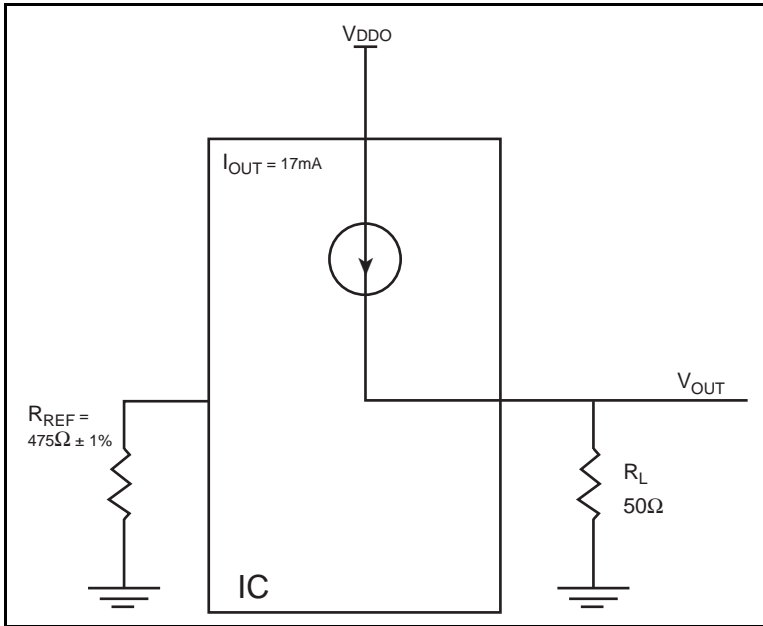

Figure 13. HCSL Driver Circuit and Termination

HCSL is a current steering output which sources a maximum of 17mA of current per output. To calculate worst case on-chip power dissipation, use the following equations which assume a 50Ω load to ground.

The highest power dissipation occurs when V_{DDO_MAX} .

$$\begin{aligned} \text{Power} &= (V_{DDO_MAX} - V_{OUT}) * I_{OUT}, \\ \text{since } V_{OUT} &= I_{OUT} * R_L \\ &= (V_{DDO_MAX} - I_{OUT} * R_L) * I_{OUT} \\ &= (3.465\text{V} - 17\text{mA} * 50\Omega) * 17\text{mA} \end{aligned}$$

Total Power Dissipation per output pair = **44.5mW**

Reliability Information

Table 8. θ_{JA} vs. Air Flow Table for a 32-Lead VFQFN

θ_{JA} vs. Air Flow			
Meters per Second	0	1	2.5
Multi-Layer PCB, JEDEC Standard Test Boards	39.5°C/W	34.5°C/W	31.0°C/W

Transistor Count

The transistor count for 8T39S04A is: 10,283

Package Outline Drawings

The package outline drawings are appended at the end of this document and are accessible from the link below. The package information is the most current data available.

www.idt.com/document/psc/nbnbg32-package-outline-50-x-50-mm-body-ep-31-mm-sq-050-mm-pitch-qfn

Ordering Information

Table 9. Ordering Information

Part/Order Number	Marking	Package	Shipping Packaging	Temperature
8T39S04ANBGI	IDT8T39S04ANBGI	32-Lead VFQFN, Lead-Free	Tray	-40°C to 85°C
8T39S04ANBG18	IDT8T39S04ANBGI	32-Lead VFQFN, Lead-Free	Tape & Reel	-40°C to 85°C

Revision History

Revision Date	Description
July 24, 2019	<ul style="list-style-type: none">• Updated Absolute Maximum Ratings• Added Recommended Operating Conditions• Completed other minor changes
May 26, 2019	Initial release.

REVISIONS			
REV	DESCRIPTION	DATE	APPROVED
00	INITIAL RELEASE	4/14/16	JH

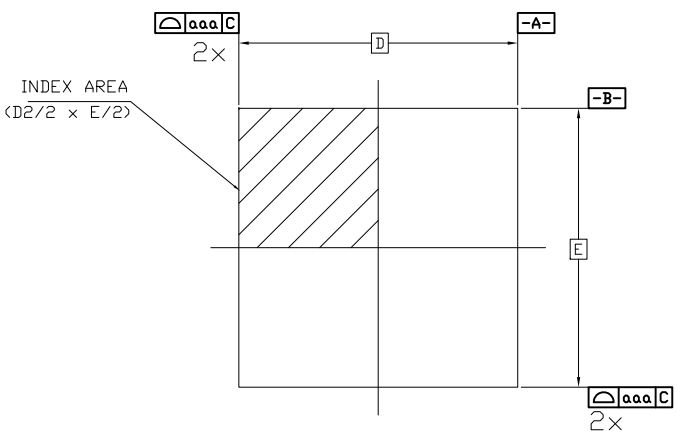

TOP VIEW

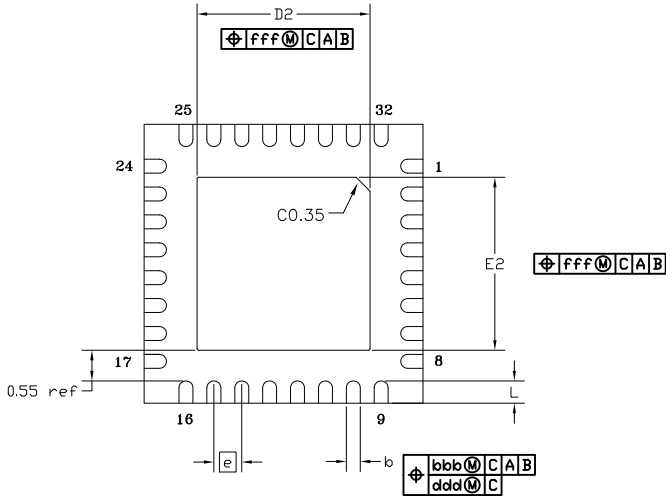

BOTTOM VIEW

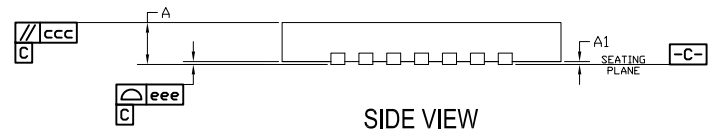

SIDE VIEW

SYMBOL	DIMENSION		
	MIN	NOM	MAX
L	0.30	0.40	0.50
D	5.00 BSC		
E	5.00 BSC		
D2	3.00	3.10	3.20
E2	3.00	3.10	3.20
e	0.50 BSC		
A	0.70	0.75	0.80
A1	0.00	0.02	0.05
b	.20	.25	.30
aaa	0.10		
bbb	0.10		
ccc	0.10		
ddd	0.05		
eee	0.08		
fff	0.10		

- NOTES:
1. ALL DIMENSIONING AND TOLERANCING CONFORM TO ANSI Y14.5M-1982
 2. ALL DIMENSIONS ARE IN MILLIMETERS.

TOLERANCES UNLESS SPECIFIED
 DECIMAL ANGULAR
 X± .1 ±1°
 XX± .05
 XXX± .030



6024 SILVER CREEK VALLEY ROAD. SAN JOSE, CA 95138
 PHONE: (408) 284-8200
 FAX: (408) 284-3572

APPROVALS	DATE
DRAWN <i>RAC</i>	4/14/16
CHECKED	

TITLE NB/NBG32 PACKAGE OUTLINE
 5.0 x 5.0 mm BODY, EP 3.1 mm SQ.
 0.50 mm PITCH QFN

SIZE	DRAWING No.	REV
C	PSC-4348-01	00
DO NOT SCALE DRAWING		SHEET 1 OF 2

REVISIONS			
REV	DESCRIPTION	DATE	APPROVED
00	INITIAL RELEASE	4/14/16	JH

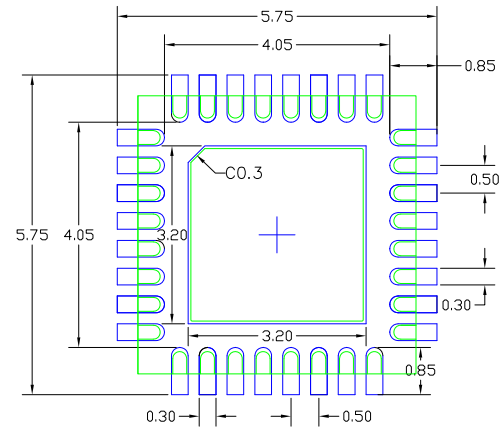

RECOMMENDED LAND PATTERN DIMENSION

NOTES:

1. ALL DIMENSIONS ARE IN mm. ANGLES IN DEGREES.
2. TOP DOWN VIEW, AS VIEWED ON PCB.
3. COMPONENT OUTLINE SHOWN FOR REFERENCE IN GREEN.
4. LAND PATTERN IN BLUE. NSMD PATTERN ASSUMED.
5. LAND PATTERN RECOMMENDATION PER IPC-7351B GENERIC REQUIREMENT FOR SURFACE MOUNT DESIGN AND LAND PATTERN.

TOLERANCES UNLESS SPECIFIED DECIMAL ANGULAR X± .1 ±1° XX± .05 XXX± .030		 www.IDT.com		6024 SILVER CREEK VALLEY ROAD, SAN JOSE, CA 95138 PHONE: (408) 284-8200 FAX: (408) 284-3572	
APPROVALS	DATE			TITLE NB/NBG32 PACKAGE OUTLINE 5.0 x 5.0 mm BODY, EP 3.1 mm SQ. 0.50 mm PITCH QFN	
DRAWN <i>RAC</i>	4/14/16	SIZE	DRAWING No.	REV	
CHECKED		C	PSC-4348-01	00	
DO NOT SCALE DRAWING				SHEET 2 OF 2	