

Description

SMA is an acronym for SubMiniature version A and was developed in the 1960's. It uses a threaded interface.

50 ohm SMA connectors are semi-precision, sub-miniature units which provide excellent electrical performance from DC to 18 GHz. These high performance connectors are compact in size and mechanically have outstanding durability.

Built in accordance with MIL-C-39012 and CECC 22110/111. They can be mated with all connectors which meet these spec mating diameters regardless of manufacturer.

Features/Benefits

- Broadband performance DC to 18 GHz with low reflection stainless steel construction with 1/4-36 threaded coupling offers high performance in a compact design.
- Low cost Commercial Grade (Brass SMA) available in nickel or gold plating, flexible provides approximately 30% reduction in cost with 250 mating cycles.
- Various flexible cable groups including: .086 and .141 semi-rigid allows customer flexibility in their design with a durable connector.

Application

- Base Stations
- Cable Assemblies
- Components
- Instrumentation
- Mil/Aero
- PC/LAN
- Process Controls
- Telecom



Stainless Steel

Specifications	56-57
Plugs	58-61
Jacks	62-63
Receptacles	64-73
In-Series Adapters	74-75

Brass

Specifications	76
Plugs, Jacks	77-78
Receptacles	79-82

Phase Adjustable Connectors

Specifications	83
Plugs and Adapters	84

ELECTRICAL

Impedance	50 ohms
Frequency range	.141" & .085" O.D. copper jacket semi-rigid cable. 0-18GHz. Flexible cables: 0-12.4 GHz.
Voltage rating	RG-55, 58, 141, 142, 223, 303: 500 volts peak RG-122, 174, 188, 316: 375 volts peak
Dielectric withstanding voltage	.141" & RG-58 group: 1,000 VRMS. .085" & RG-316 group: 750 VRMS.
VSWR (straight connectors)	.141" O.D. copper jacket cable: 1.05 + .005 f (GHz) RG-55 group: 1.15 + .011 f (GHz) RG-122 group: 1.15 + .02 f (GHz) RG-178 group: 1.20 + .025 f (GHz)
(angle connectors)	.141" O.D. copper jacket cable: 1.10 + .01 f (GHz) RG-55 group: 1.15 + .02 f (GHz) RG-122 group: 1.15 + .03 f (GHz) RG-178 group: 1.20 + .03 f (GHz)
Contact resistance	Center: 2.0 milliohms Body: 2.0 milliohms Braid to body: 0.5 milliohms
Insulation resistance:	5000 megohms
RF leakage	-60 dB minimum
Insertion loss:	.03 $\sqrt{f(\text{GHz})}$ dB max.

ENVIRONMENTAL

Temperature range	-65°C to + 165°C
Thermal shock	MIL-Std. 202 method 107 (test cond. B) except high temp test @ + 200°C
Vibration	MIL-Std. 202 method 204 (test cond. D)
Shock	MIL-Std. 202 method 213 (test cond. I) No discontinuity permitted.
Corrosion	MIL-Std. 202 method 101 (test cond. B) 5% salt solution.
Moisture resistance	MIL-Std. 202 method 106, except step 7b (vibration) omitted, and high humidity measurements do not apply.
Weatherproofing	Crimp type: heat shrink tubing Solder type: silicone rubber gaskets
Altitude	MIL-Std. 202 method 105 (test cond. C), no corona at 70,000 ft. .141" & RG-55 group: 250 VRMS. .085" & RG-122 group: 190 VRMS.

MECHANICAL

Mating	.250-36 threaded coupling
Mating torque	Minimum: 2 inch pounds 22 N.cm Recommended: 7 to 10 inch pounds 80-110 N.cm Maximum: 15 inch pounds 170 N.cm
Coupling nut retention	Axial force: 100 lbs. min., 300 N.cm Torque: 15 in. lbs. min. 76 N.cm Jacks: N/A
Connector affixment to cable	Crimp types, solder types
Cable affixment to center contact	Solder, except as noted
Contact captivation	All types, except as noted
Cable retention	Crimp type for RG-58, .141, 303=60 lbs min.; for RG-55, 142, 223 = 80 lbs min. 400 N.cm
Connector durability	500 mating and unmating cycles @ 12 cycles per min.

MATERIAL

Bodies, coupling nuts, other metal parts (except as noted)	Non-magnetic stainless steel per QQ-S-764, Type 303.
Contacts	Beryllium copper per QQ-C-530, heat treated per MIL-H-7199.
Plating: Center contacts.	.00005" min. gold per MIL-G-45204, type 1, grade C. Gold over nickel unless otherwise requested.
Plating: Other metal parts	Gold plated or passivated to meet the finish and corrosion requirements of MIL-C-39012.
Insulators	TFE fluorocarbon per ASTM D1457.
Gaskets	Silicone rubber, per MIL-R-5847 and ZZ-R-765. class IIB, grade 65-75.
Lockwashers	Stainless steel, internal-tooth supplied with all bulkhead mounted connectors.
Crimp ferrules	Seamless copper tubing alloy # 122 (DHP), hard drawn to Rockwell 58-77 on 30-T scale per ASTM B75.

MILITARY SPECIFICATIONS

MIL-C-39012 & MIL-C-83517 SMA specification sheets	As applicable
--	---------------

NOTE: These characteristics are typical and may not apply to all connectors.

Plug

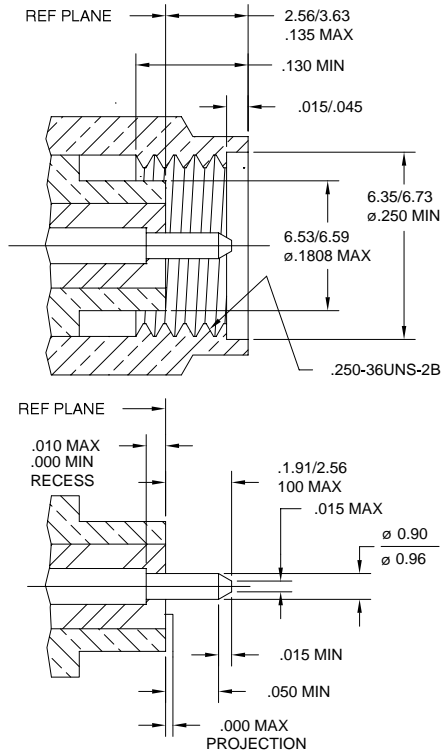

Jack

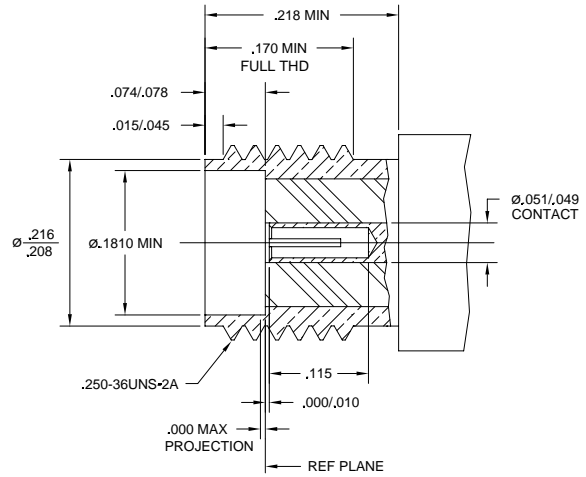



CECC = Cenelec Electronic Components Committee in Europe

<p>Fig. 1</p> <p>SMA Plugs - Solder to Body 901-9201-2A for .085" (2.2mm) S/R, RG-405 (M17/133) Gold Plated Nut [VSWR = 1.07 + .008(GHz) DC-18GHz] 901-9201-2ASF for .085" (2.2mm) S/R, RG-405 (M17/130) Gold Plated Passivated Nut 901-9201-1A for .141" (3.6mm) S/R, RG-402 (M17/130) Gold Plated Nut, without Contact & Insulator 901-9201-1ASF for .141" (3.6mm) S/R, RG-402 (M17/130) Gold Plated Passivated Nut</p>		<p>Fig. 2</p> <p>VSWR = 1.35 max. DC-22GHz</p> <p>SMA Plugs - Solder to Body/ Pre-assembled Factory-Set Interface 901-9723-10 Passivated Nut, 100 piece Bulk Pack 901-9723-10 Passivated Nut, Single Pack for .085" (2.2mm) S/R, RG-405 (M17/133)</p>	
<p>Fig. 3</p> <p>VSWR = 1.35 max. DC-22GHz</p> <p>901-9808-1 Gold Body, Passivated Nut 901-9808-1 Gold Body and Nut 901-9808-2 Gold Body, Passivated Nut Preassembled Factory Set Interface Single Pack for .141" (3.6mm) S/R , RG-402 (M17/130)</p>		<p>Fig. 4</p> <p>SMA Plugs - Solder to Body/ Pre-assembled Factory-Set Interface 901-9805-HP Passivated Nut, Single Pack for .085" (2.2mm) S/R, RG-405 (M17/133)</p>	

SMA PLUGS FOR SEMI-RIGID CABLE – 50Ω impedance

Cable RG-/U	Cable Attachment		Dim. In. (mm)		CAI	Plt.	Ins.	Construction Notes	Amphenol Number	Fig.
	Outer	Inner	a	c						
.085" (2.2mm) Semi-Rigid RG-405 (M17/133)	Solder	Solder	.438(11.1)	.090(2.3)	C47	P10	D1	—	901-9201-2A	1
	Solder	Plugable	.400(10.2)	.090(2.3)	C48	P10	D1	—	901-9201-2ASF	1
	Solder	Plugable	.400(10.2)	.090(2.3)	C48	P10	D1	—	▲ 901-9723	2
	Solder	Plugable	.400(10.2)	.090(2.3)	C48	P11	D1	—	901-9723-10	2
	Solder	Plugable	.531(13.5)	.090(2.3)	C48	P11	D1	—	901-9805-HP	4
.141" (3.6mm) Semi-Rigid RG-402 (M17/130)	Solder	None	.445(11.3)	.145(3.7)	C50	P14	—	w/o Cont. & Ins.	901-9201-1A	1
	Solder	None	.445(11.3)	.145(3.7)	C50	P14	—	Gold plated bodyⓄ	▲ 901-9201-1ASF	1
	Solder	Plugable	.438(11.1)	.145(3.7)	C48	P10	D1	Gold plated bodyⓄ	901-9808	3
	Solder	Plugable	.438(11.1)	.145(3.7)	C48	P10	D1	Gold plated bodyⓄ	901-9808-1	3
	Solder	Plugable	.438(11.1)	.145(3.7)	C48	P10	D1	Gold plated bodyⓄ	901-9808-2	3

▲ distributor stocked Ⓞ passivated nut

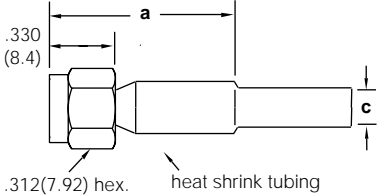
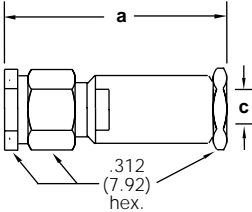
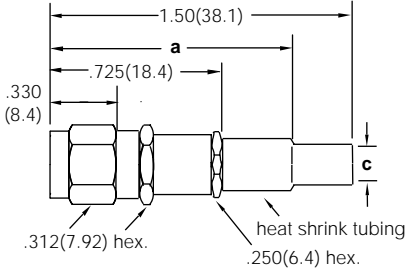
<p>Fig. 1</p> 	<p>Fig. 2</p> 	<p>Fig. 3</p> 
 <p>SMA Plug Braid Solder to Body Captivated Solder Contact 901-9501-3 for RG-174, 179B, 187A, 188A, 316</p>	 <p>SMA Plugs BeCu Body, Solder to Nut 901-103-▲ for RG-55, 58, 142, 223 901-128-11-• (M39012/55-4007) for RG-174, 316</p>	 <p>SMA Plugs Braid Crimp/ Captivated Solder Contact 901-9601-1SF▲ Passivated Body & Nut for RG-55B, 142B, 223, 400 901-9601-3▲ Gold Plt. Body & Nut 901-9601-3SF▲ Passivated Body & Nut for RG-174, 179, 187, 188, 316</p>

SMA PLUGS FOR FLEXIBLE CABLE – 50Ω impedance

Cable RG-/U	Cable Attachment		Dim. In. (mm)		CAI	Plt.	Ins.	Construction Notes	Mil. No. 39012/	Amphenol Number	Fig.
	Outer	Inner	a	c							
55, 58, 141, 142, 223	Clamp	Solder	.969(24.6)	.219(5.6)	C43	P9	D1	BeCu Body	—	•▲ 901-103	2
55B, 142B, 223, 400	Crimp	Solder	1.10(28.0)	.220(5.6)	C56	P12	D1	Captivated Contact	—	▲ 901-9601-1SF	3
174, 179, 187, 188, 316	Crimp	Solder	1.10(28.0)	.128(3.3)	C56	P9	D1	Captivated Contact	—	▲ 901-9601-3	3
	Crimp	Solder	1.10(28.0)	.128(3.3)	C56	P12	D1	Captivated Contact	—	▲ 901-9601-3SF	3
174, 179B, 187A, 188A, 316	Solder	Solder	.690(17.5)	.128(3.3)	C46	P11	D1	—	—	901-9501-3	1
174, 316	Clamp	Solder	.984(25.0)	.114(2.9)	C44	P9	D1	BeCu Body	55-4007	• 901-128-11	2

• safety wire holes ▲ distributor stocked

Fig. 1

SMA Plugs
Braid Crimp/
Non-Captivated Solder Contact

901-9511-1▲
Gold Plt. Body & Nut
901-9511-1SF▲
Passivated Body & Nut
for RG-55B, 142B, 223, 400

901-9511-3▲
Gold Plt. Body & Nut
901-9511-3SF▲
Passivated Body & Nut
for RG-174, 179, 187, 188, 316

901-9511-12SF▲
Passivated Body & Nut
for Double Braid RG-316

901-9511-2
Gold Plt. Body & Nut
901-9511-2SF
Passivated Body & Nut
for RG-58

901-10011
Passivated Body & Nut
for LMR 240

901-10012
Passivated Body & Nut
for LMR 200

Fig. 2

SMA Plugs
Braid Crimp/
Crimp Center Contact
with Passivated Body & Nut

901-9511-1SFC
for RG-55B, 142B, 223, 400

901-101-15†
BeCu Body
(M39012/55-4502)
for RG-142B, 400



901-9511-3SFC
for RG-174, 179, 187, 188, 316

901-9511-12SFC
for Double Braid RG-316

SMA PLUGS FOR FLEXIBLE CABLE – 50Ω impedance

Cable RG-/U	Cable Attachment		Dim. In. (mm)		CAI	Plt.	Ins.	Construction Notes	Mil. No. 39012/	Amphenol Number	Fig.
	Outer	Inner	a	c							
55B, 142B, 223, 400	Crimp	Solder	.812(20.6)	.220(5.6)	C53	P10	D1	Non-Captive Contact	—	▲ 901-9511-1	1
55B, 142B, 223, 400	Crimp	Solder	.812(20.6)	.220(5.6)	C53	P13	D1	Non-Captive Contact	—	▲ 901-9511-1SF	1
58	Crimp	Solder	.812(20.6)	.206(5.2)	C53	P11	D1	—	—	901-9511-2	1
58	Crimp	Solder	.812(20.6)	.206(5.2)	C53	P10	D1	—	—	901-9511-2SF	1
174, 187, 188, 316	Crimp	Solder	.812(20.6)	.128(3.3)	C55	P10	D1	Non-Captive Contact	—	▲ 901-9511-3	1
174, 187, 188, 316	Crimp	Solder	.812(20.6)	.128(3.3)	C55	P13	D1	Non-Captive Contact	—	▲ 901-9511-3SF	1
Dbl. Braid RG-188, 316	Crimp	Solder	.812(20.6)	.142(3.6)	C55	P13	D1	Non-Captive Contact	—	▲ 901-9511-12SF	1
LMR 240	Crimp	Solder	1.03(26.2)	.261(6.6)	C53	P13	D1	Non-Captive Contact	—	901-10011	1
LMR 200	Crimp	Solder	.810(20.6)	.206(5.2)	C53	P13	D1	Non-Captive Contact	—	901-10012	1
55B, 142B, 223, 400	Crimp	Crimp	.812(20.6)	.220(5.6)	C55	P13	D1	—	—	901-9511-1SFC	2
142B, 400	Crimp	Crimp	1.03(26.2)	.220(5.6)	C55	P9	D1	BeCu Body	55-4502	† 901-101-15	2
174, 179, 187, 188, 316	Crimp	Crimp	.812(20.6)	.128(3.5)	C55	P13	D1	—	—	901-9511-3SFC	2
Dbl. Braid RG-188, 316	Crimp	Crimp	.812(20.6)	.142(3.6)	C55	P13	D1	—	—	901-9511-12SFC	2



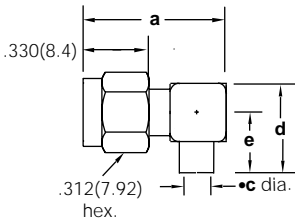
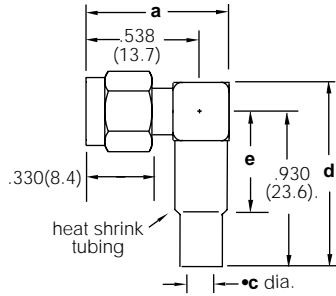
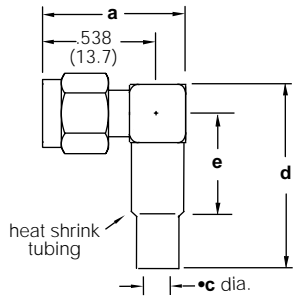

• safety wire holes † for crimping center contact, use Tool Handle M22520/1-01 and Crimp Die M22520/1-15 ▲ distributor stocked

<p>Fig. 1</p> 	<p>Fig. 2</p> 	<p>Fig. 3</p> 
 <p>SMA Angle Plugs Solder to Body 901-9221-2A Gold Plated Nut 901-9221-2ASF Passivated Nut for 085" (2.2mm) S/R RG-405 (M17/133) 901-9221-1A Gold Plated Nut 901-9221-1ASF Passivated Nut for 141" (3.6mm) S/R RG-402 (M17/130)</p>	 <p>SMA Angle Plugs Solder to Nut 901-9531-1▲ Gold Plt. Body & Nut for RG-55, 142, 223, 400 901-9531-2 Gold Plt. Body & Nut 901-9531-2SF Passivated Body for RG-58, 141 901-9531-1SF▲ Passivated Body for SF142B 901-9531-3▲ Gold Plt. Body & Nut 901-9531-3SF▲ Passivated Body for RG-174, 179, 187, 188, 316 901-9531-12▲ Gold Plt. Body & Nut 901-9531-12SF▲ Passivated Body for Double Braid RG-316 901-10014 Passivated Body & Nut for LMR240</p>	 <p>SMA Angle Plugs Braid Solder, Solder Contact 901-9521-3▲ for RG-174, 179, 187, 187A, 188, 188A, 316</p>

SMA RIGHT ANGLE PLUGS FOR SEMI-RIGID & FLEXIBLE CABLE – 50Ω impedance

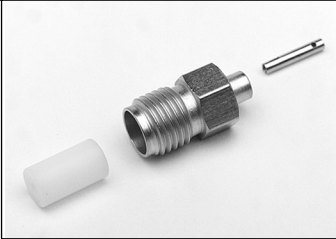
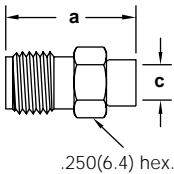
Cable RG-/U	Cable Attachment		Dim. In. (mm)				CAI	Plt.	Ins.	Notes	Mil. No. 39012/	Amphenol Number	Fig.
	Outer	Inner	a	c	d	e							
.085" (2.2mm) Semi-Rigid RG-405 (M17/133)	Solder	Solder	.680(17.3)	.090(2.3)	.430(10.9)	.305(7.7)	C49	P11	D1	—	—	901-9221-2A	1
	Solder	Solder	.680(17.3)	.090(2.3)	.430(10.9)	.305(7.7)	C49	P11	D1	—	—	901-9221-2ASF	1
.141" (2.2mm) Semi-Rigid RG-402 (M17/130)	Solder	Solder	.680(17.3)	.145(3.7)	.430(10.9)	.305(7.7)	C49	P11	D1	—	—	901-9221-1A	1
	Solder	Solder	.680(17.3)	.145(3.7)	.430(10.9)	.305(7.7)	C49	P11	D1	—	—	901-9221-1ASF	1
55, 141, 142, 223, 400	Crimp	Solder	.682(17.3)	.220(5.6)	1.05(26.7)	.550(14.0)	C53	P11	D1	Cap. Cont.	—	▲ 901-9531-1	2
58, 141	Crimp	Solder	.682(17.3)	.206(5.2)	1.05(26.7)	.550(14.0)	C53	P11	D1	—	—	901-9531-2	2
	Crimp	Solder	.682(17.3)	.206(5.2)	1.05(26.7)	.550(14.0)	C53	P13	D1	—	—	901-9531-2SF	2
174, 187, 188, 316	Crimp	Solder	.682(17.3)	.128(3.3)	1.05(26.7)	.550(14.0)	C57	P11	D1	Cap. Cont.	—	▲ 901-9531-3	2
	Crimp	Solder	.682(17.3)	.128(3.3)	1.05(26.7)	.550(14.0)	C57	P13	D1	Cap. Cont.	—	▲ 901-9531-3SF	2
174, 179, 187, 187A, 188, 188A, 316	Solder	Solder	.675(17.1)	.128(3.3)	1.12(28.4)	.440(11.2)	C46	P11	D1	—	—	▲ 901-9521-3	3
SF 142B, Times AA-2423	Crimp	Solder	.675(17.1)	.219(5.6)	1.06(26.9)	.475(12.1)	C53	P13	D1	—	—	▲ 901-9531-1SF	2
Double Braid RG-316	Crimp	Solder	.682(17.3)	.142(3.6)	1.05(26.7)	.550(14.0)	C57	P11	D1	Cap. Cont.	—	▲ 901-9531-12	2
	Crimp	Solder	.682(17.3)	.142(3.6)	1.05(26.7)	.550(14.0)	C57	P13	D1	Cap. Cont.	—	▲ 901-9531-12SF	2
LMR 240	Crimp	Solder	.682(17.3)	.261(1.7)	1.00(25.4)	.685(17.4)	C57	P13	D1	—	—	901-10014	2

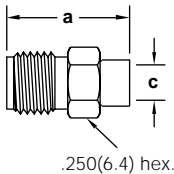
▲ distributor stocked

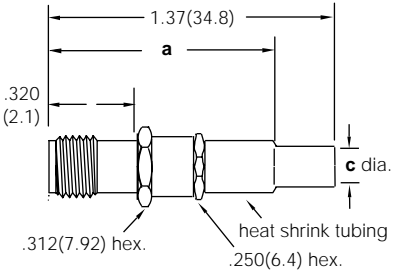
<p>Fig. 1</p>   <p style="text-align: center;">SMA Jacks Solder to Body Solder Center Contact 901-9202-1A for .141" (3.6mm) S/R RG-402 (M17/130) 901-9202-2A for .085" (2.2mm) S/R RG-405 (M17/133)</p>	<p>Fig. 2</p>   <p style="text-align: center;">SMA Jack Solder to Body Pre-assembled Center Contact 901-9704 Gold Plated for .141" (3.6mm) S/R RG-402 (M17/130)</p>	<p>Fig. 3</p>   <p style="text-align: center;">SMA Jacks Braid Crimp Solder Captive Contact 901-9602-1 Gold Plated, 901-9602-1SF Passivated for RG-55B, 142B, 223, 400 901-9602-3 Gold Plated, 901-9602-3SF Passivated for RG-174, 179, 187, 188, 316 901-9602-12SF Passivated for Double Braid RG-316</p>
---	---	---

SMA JACKS FOR SEMI-RIGID & FLEXIBLE CABLES – 50Ω Impedance



Cable RG-/U	Cable Attachment		Dimensions In. (mm)		CAI	Plt.	Ins.	Notes	Amphenol Number	Fig.
	Outer	Inner	a	c						
.085" (3.6mm) Semi -Rigid (RG-405) (M17/133)	Solder to Body	Solder	.500(12.7)	.088(2.2)	C47	P9	D1	—	901-9202-2A	1
.141" (3.6mm) Semi -Rigid RG-402 (M17/130)	Solder to Body	Solder	.500(12.7)	.144(3.7)	C47	P10	D1	—	901-9202-1A	1
	Solder to Body	Solder	.500(12.7)	.144(3.7)	C59	P11	D1	Pre-assembled Cont.	901-9704	2
55, 142, 223, 400	Crimp	Solder	.965(24.5)	.220(5.6)	C56	P9	D1	Captive Contact	901-9602-1	3
	Crimp	Solder	.965(24.5)	.220(5.6)	C56	P12	D1	Captive Contact	901-9602-1SF	3
174, 179, 187, 188, 316	Crimp	Solder	.965(24.5)	.128(3.3)	C56	P9	D1	Captive Contact	901-9602-3	3
	Crimp	Solder	.965(24.5)	.128(3.3)	C56	P12	D1	Captive Contact	901-9602-3SF	3
Double Braid RG-316	Crimp	Solder	.965(24.5)	.142(3.6)	C56	P12	D1	Captive Contact	901-9602-12SF	3

<p>Fig. 1</p> <p>SMA Bulkhead Jacks Solder to Body Solder Center Contact Gold Plated 901-9210-1 for .141" (3.6mm) S/R RG-402 (M17/130) 901-9210-2 for .085" (2.2mm) S/R RG-405 (M17/133)</p>	<p>Fig. 2</p> <p>SMA Bulkhead Jacks Braid Crimp Captive Contact Solder Center Contact 901-9610-1SF▲ Passivated for RG-55B, 142B, 223, 400 901-9610-3▲ Gold Plated 901-9610-3SF▲ Passivated for RG174, 179, 187, 188, 316 901-9610-12SF Passivated for Double Braid RG-316 901-10015 Passivated for LMR 240</p>	<p>Fig. 3</p> <p>SMA Bulkhead Jacks Braid Crimp Solder Center Contact 901-10021-1SF▲ Passivated for RG-55B, 142B, 223, 400 901-10021-3SF▲ Passivated for RG174, 179, 187, 188, 316 901-10021-12SF Passivated for Double Braid RG-316</p>
--	---	---

SMA BULKHEAD JACKS FOR SEMI-RIGID & FLEXIBLE CABLES – 50Ω Impedance

Cable RG-/U	Cable Attachment		Dimensions In. (mm)		CAI	Plt.	Ins.	Notes	Amphenol Number	Fig.
	Outer	Inner	a	c						
.085" (2.2mm) Semi-Rigid RG-405 (M17/133)	Solder to Body	Solder	.750(19.1)	.090(2.3)	C47	P9	D1	—	901-9210-2	1
.141" (3.6mm) Semi-Rigid RG-402 (M17/130)	Solder to Body	Solder	.750(19.1)	1.44(3.7)	C47	P10	D1	—	901-9210-1	1
55, 142, 223, 400	Crimp	Solder	1.50(38.1)	.220(5.6)	C56	P13	D1	Capt. Contact	▲ 901-9610-1SF	2
	Crimp	Solder	1.50(38.1)	.220(5.6)	C56	P13	D1	Non Capt. Contact	▲ 901-10021-1SF	3
174, 179, 187, 188, 316	Crimp	Solder	1.50(38.1)	.128(3.3)	C56	P11	D1	Capt. Contact	▲ 901-9610-3	2
	Crimp	Solder	1.50(38.1)	.128(3.3)	C56	P11	D1	Non Capt. Contact	▲ 901-10021-3SF	3
	Crimp	Solder	1.50(38.1)	.128(3.3)	C56	P13	D1	Capt. Contact	▲ 901-9610-3SF	2
Double Braid 316	Crimp	Solder	1.50(38.1)	.128(3.3)	C56	P13	D1	Non Capt. Contact	▲ 901-10021-12SF	3
	Crimp	Solder	1.50(38.1)	.142(3.6)	C56	P13	D1	Capt. Contact	901-9610-12SF	2
LMR 240	Crimp	Solder	1.08(27.4)	.261(6.6)	C56	P13	D1	Capt. Contact	901-10015	2

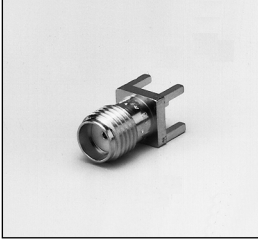
▲ distributor stocked

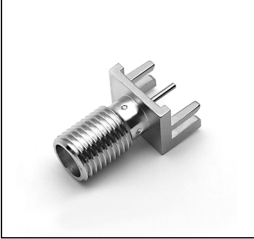
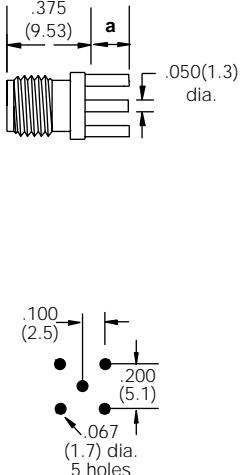
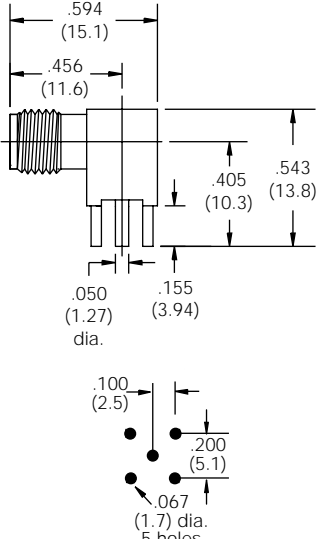
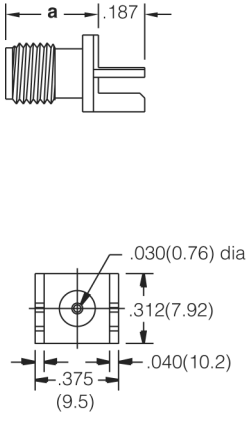
<p>Fig. 1</p> 	<p>Fig. 2</p> 	<p>Fig. 3</p> 
 <p>SMA Printed Circuit Receptacle Gold Plated Blunt Post Terminal Four Legs 901-144▲ .155(3.9) Legs & Term. 901-144-2 .105(2.7) Solder Dipped Legs & Term. 901-144-3 .155(3.9) Solder Dipped Legs & Term. 901-144-4 .200(5.1) Legs & Term with Stand-off Pads</p>	 <p>SMA Printed Circuit Receptacle Gold Plated Blunt Post Terminal Four Legs .025 Stand-off Pads 901-143▲ .155(3.9) Legs & Term. 901-143-3 .155(3.9) Solder Dipped Legs & Term. 901-143-4 .105(2.7) Solder Dipped Legs & Term.</p>	 <p>SMA Printed Circuit Receptacle Edge Mount 901-9850 for .062" Printed Circuit Board 901-10003 for .062" Printed Circuit Board 901-10019 for .032" Printed Circuit Board</p>

SMA PRINTED CIRCUIT RECEPTACLES – female contacts

Description	Terminal Type	Plt.	Ins.	MTG Hole	Construction Notes	Dim. a	Amphenol Number	Fig.
Printed Circuit Board Panel Jack Receptacle	Blunt Post	P11	D1	T	Captive Contact	.155(3.9)	▲ 901-144	1
					Solder Dipped Legs & Term	.105(2.7)	901-144-2	1
					Solder Dipped Legs & Term	.155(3.9)	901-144-3	1
					.025 Stand-off Pads	.200(5.1)	901-144-4	1
Printed Circuit Board Angle Jack Receptacle	Blunt Post	P11	D1	T	.025 Stand-off Pads	.155(3.9)	▲ 901-143	2
					Solder Dipped Legs & Term	.155(3.9)	901-143-3	2
					Solder Dipped Legs & Term	.105(2.7)	901-143-4	2
Printed Circuit Board Edge Mt Jack Receptacle	Blunt Post	P10	D1	—	For .062" Thick PCB	.475 (12)	901-9850	3
					For .062" Thick PCB	.375 (9.5)	901-10003	3
					For .032" Thick PCB	.350(8.9)	901-10019	3



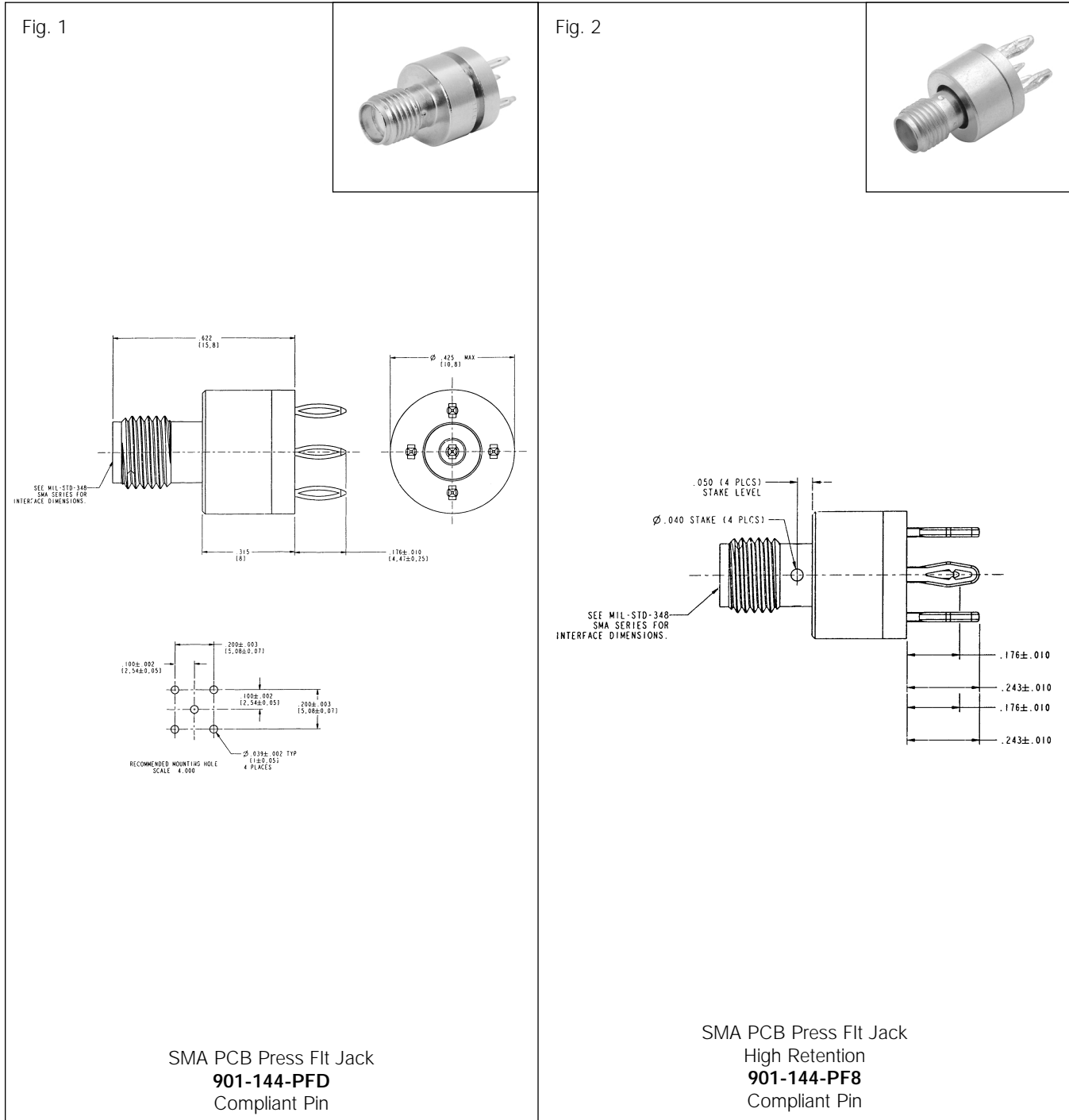

▲ distributor stocked

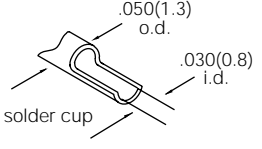
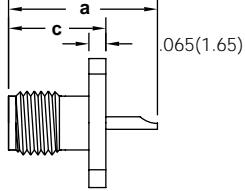
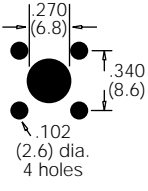
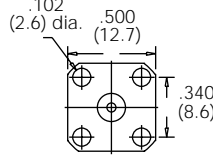

SMA PCB PRESS FIT JACKS

Description	Terminal Type	Plt.	Ins.	Construction Notes	Amphenol Number	Fig.
SMA PCB Press-Fit Jack	Compliant Pin	P11	D1	Gold Plated Body, Legs Tin/Lead	901-144-PFD	1
SMA PCB Press-Fit Jack	Compliant Pin	P11	D1	Gold Plated Body, Legs Tin/Lead	901-44-PF8	2

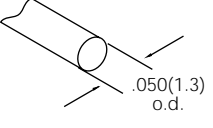
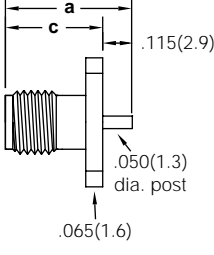
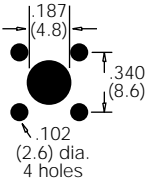
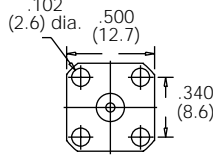
Panel Jack Receptacles – 4-hole Flange

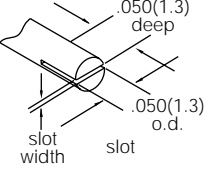
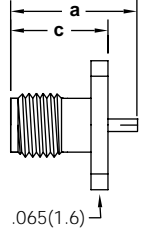
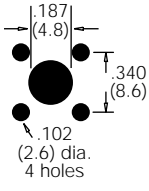
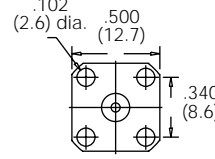
<p>Fig. 1</p>      <p>SMA Panel Jack Receptacle 4-Hole Square Flange Mount Solder Cup Terminal 901-9215 Gold Plated Body 901-9215-SF Passivated Body</p>	<p>Fig. 2</p>      <p>SMA Panel Jack Receptacle 4-Hole Square Flange Mount Post Terminal Flush TFE Countersink Flange Holes 901-9758</p>	<p>Fig. 3</p>      <p>SMA Panel Jack Receptacle 4-Hole Square Flange Mount Slot Terminal 901-9204-4CC Gold Plated Body 901-9204-4CCSF Passivated Body 901-9204-3CCSF Passivated Body</p>
--	--	---

SMA PANEL JACK RECEPTACLES – 4-hole square flange mount

Terminal Type	Dimensions In. (mm)		Plt.	Ins.	Notes	Amphenol Number	Fig.
	a	c					
Solder Cup .200"(5.1mm) Long	.575(14.6)	.375(9.5)	P10	D1	Captive Contact, Gold Plt. Body	901-9215	1
	.575(14.6)	.375(9.5)	P13	D1	Captive Contact, Passivated Body	901-9215-SF	1
Slot .015"(0.4mm) Wide	.425(10.8)	.375(9.5)	P9	D1	Captive Contact, Gold Plt. Body	901-9204-4CC	3
	.425(10.8)	.375(9.5)	P12	D1	Captive Contact, Passivated Body	901-9204-4CCSF	3
Slot .030"(0.8mm) Wide	.425(10.8)	.375(9.5)	P12	D1	Captive Contact, Passivated Body	901-9204-3CCSF	3
Blunt Post .115"(2.9mm) Long	.490(12.4)	.375(9.5)	P13	D1	Captive Contact, Passivated Body	901-9758	2

SMA Panel Jack Receptacles – 4-hole Flange

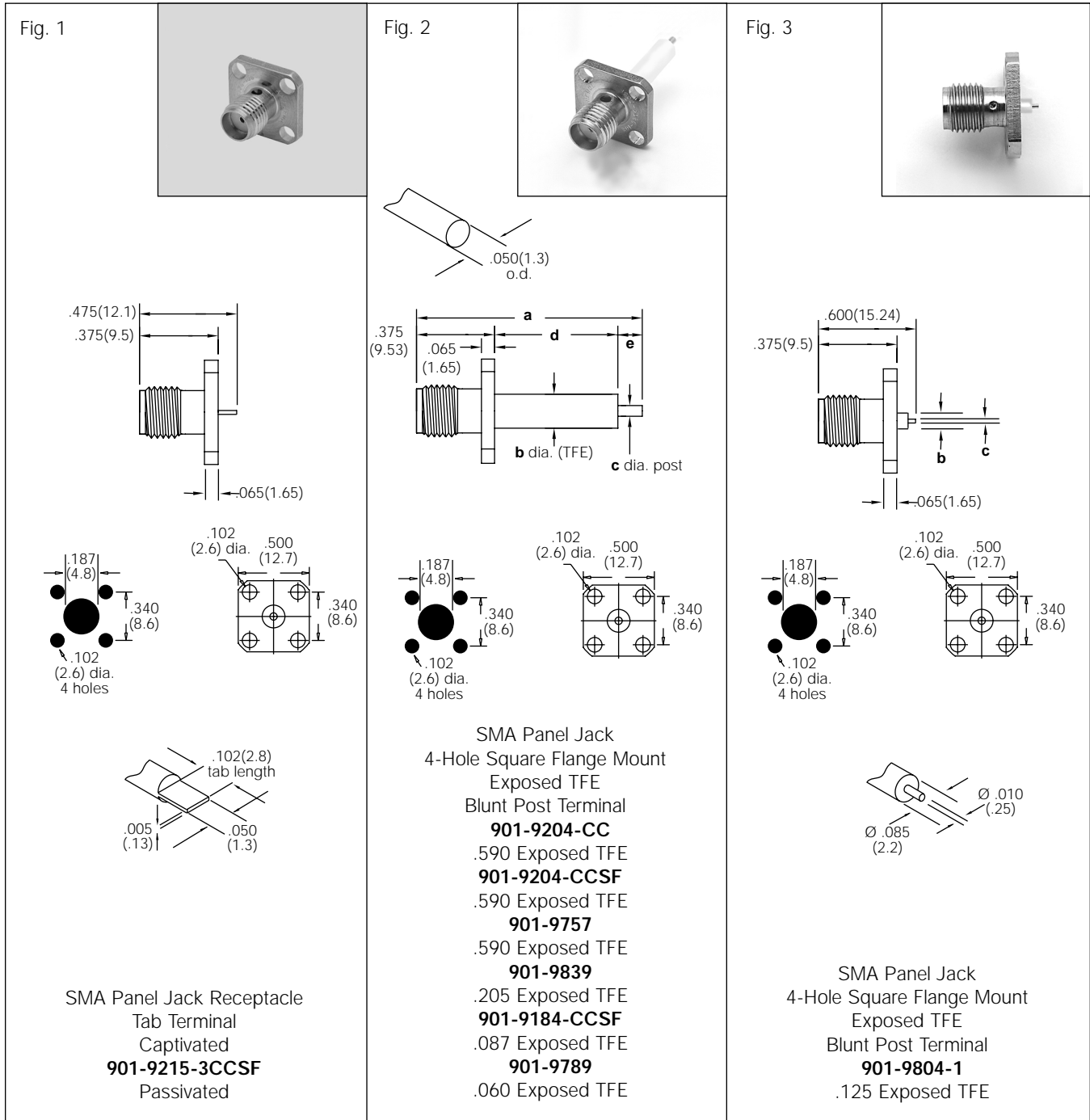

SMA PANEL JACK RECEPTACLES – 4-hole square flange mount

Terminal Type	Dimensions In. (mm)					Plt.	Ins.	Amphenol Number	Fig.
	a	b	c	d	e				
Blunt Post	1.08(27.4)	.162(4.1) dia	.050(1.3) dia	.590(15.0)	.115(2.9)	P9	D1	901-9204-CC	2
	1.08(27.4)	.162(4.1) dia	.050(1.3) dia	.590(15.0)	.115(2.9)	P13	D1	901-9204-CCSF	2
Blunt Post	1.08(27.4)	.162(4.1) dia	.050(1.3) dia	.590(15.0)	.115(2.9)	P13	D1	901-9757	2
Blunt Post	.640(16.2)	.162(4.1) dia	.050(1.3) dia	.205(5.2)	.060(1.5)	P13	D1	901-9839	2
Blunt Post	.562(14.3)	.162(4.1) dia	.050(1.3) dia	.087(2.2)	.100(2.5)	P13	D1	901-9184-CCSF	2
Blunt Post	.560(14.2)	.162(4.1) dia	.050(1.3) dia	.060(1.5)	.125(3.2)	P13	D1	901-9789	2
Blunt Post, Solder Dipped	—	.085(2.2) dia	.010(0.3) dia	—	—	P13	D1	901-9804-1	3
Tab † .100 (2.5) Long	Captive Contact, Flush TFE, Conforms to M83517/1-31004 (NQ)*					P12	D1	901-9215-3CCSF	1

Panel Plug Receptacles – 4-hole Flange

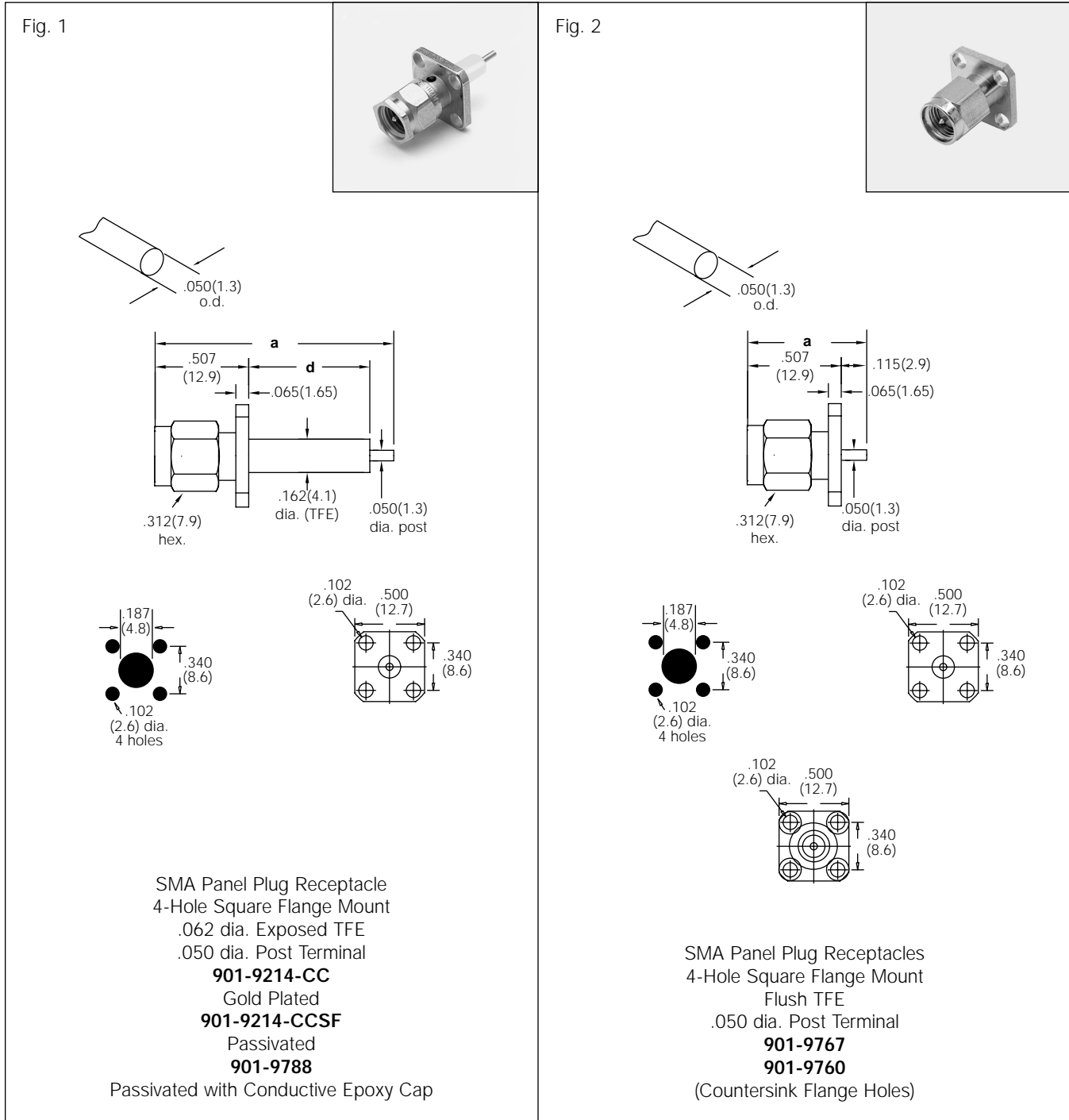

SMA PANEL PLUG RECEPTACLES – 4-hole square flange

Description	Dim Inches (mm)		Plt.	Ins.	Construction Notes	Amphenol Number	Fig.	
	a	d						
Blunt Post/.158(4.0) Long	.995(25.3)	.330(8.4)	P9	D1	Captive Contact/.330(8.4) Exposed TFE	Gold Plated Body	901-9214-CC	1
Blunt Post/.158(4.0) Long	.995(25.3)	.330(8.4)	P12	D1	Captive Contact/.330(8.4) Exposed TFE	Passivated Body	901-9214-CCSF	1
Blunt Post/.115(2.9) Long	1.21(30.8)	.590(15.0)	P13	D1	Captive Contact/.590(15.0) Exposed TFE	Passivated Body	901-9788	1
Blunt Post/.115(2.9) Long	.622(15.8)	—	P13	D1	Captive Contact/Flush TFE	Passivated Body	901-9767	2
Blunt Post/.115(2.9) Long	.622(15.8)	—	P13	D1	Captive Contact/Flush TFE C'sink Flange Holes	Passivated Body	901-9760	2

SMA Panel Jack Receptacles – 2-hole Flange

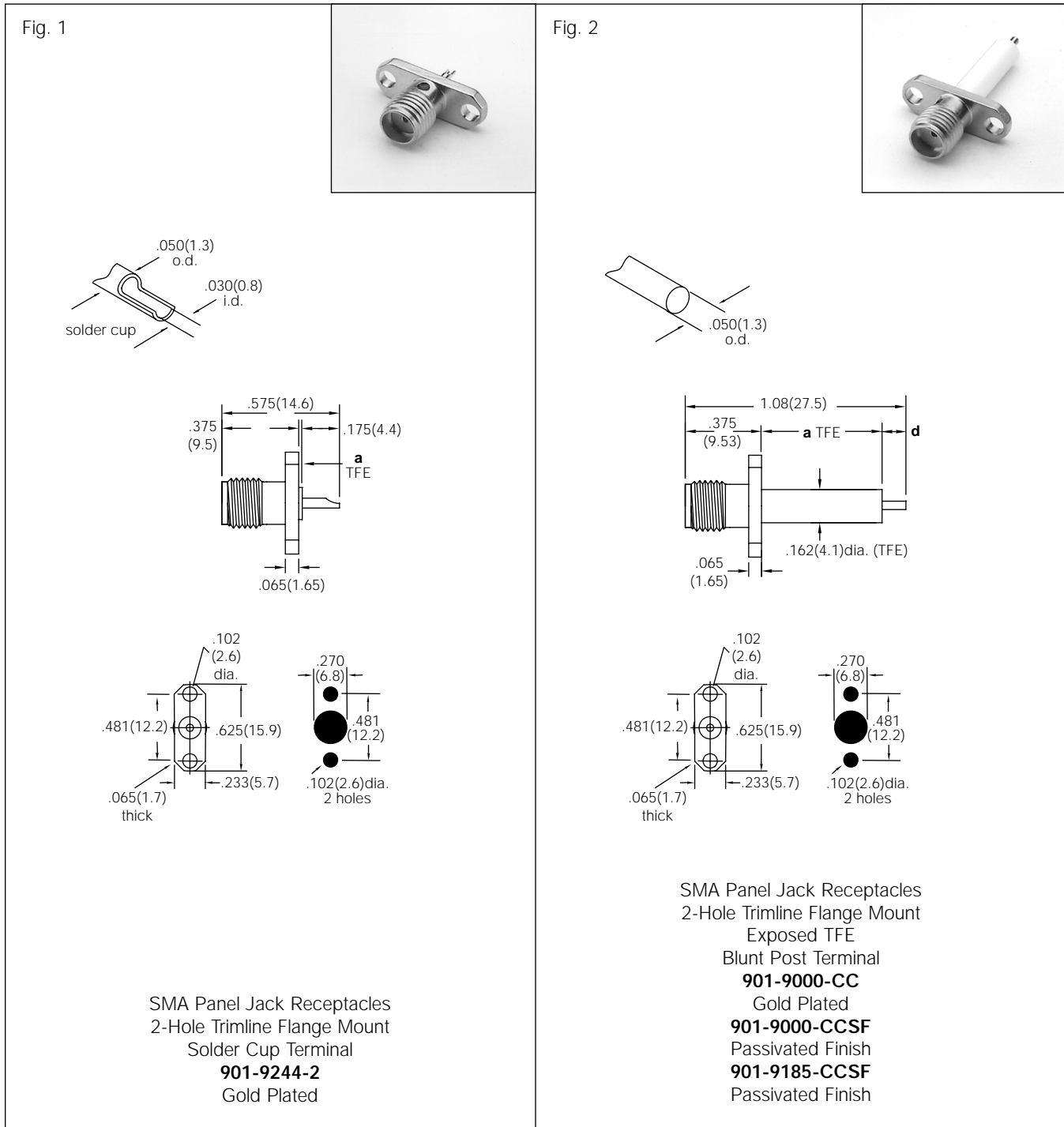

SMA PANEL JACK RECEPTACLES – 2-hole trimline flange

Description	Terminal Type	Plt.	Ins.	Construction Notes		Amphenol Number	Fig.
Panel Jack Receptacle	Solder Cup	P10	D1	Captive Contact/ a= .025" (0.6mm) Exposed TFE	Gold Plated	901-9244-2	1
Panel Jack Receptacle	Blunt Post	P10	D1	Captive Contact/d=.117(3.0) Long Post a= .590" (15.0mm) Exposed TFE	Gold Plated	901-9000-CC	2
		P13	D1		Passivated	901-9000-CCSF	2
Panel Jack Receptacle	Blunt Post	P13	D1	Captive Contact/d=.103(2.6) Long Post a= .334" (8.5mm) Exposed TFE	Passivated	901-9185-CCSF	2

Panel Jack Receptacles – 2-hole Flange

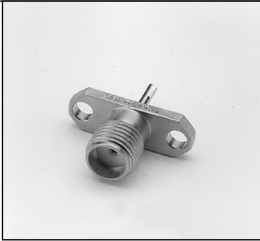
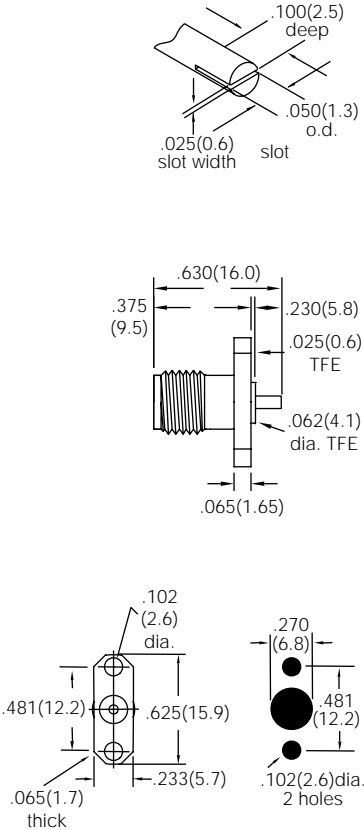
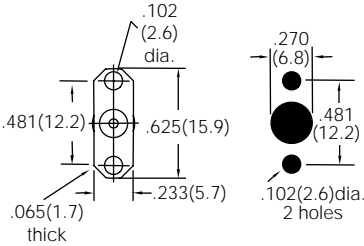
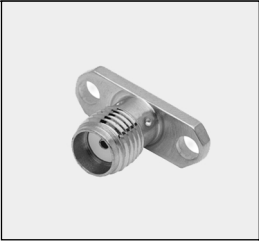
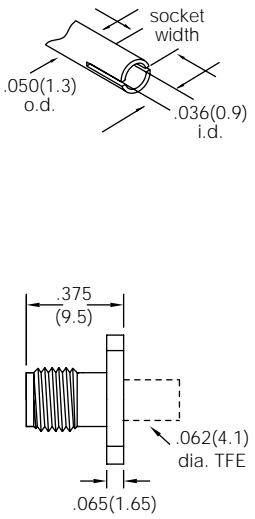
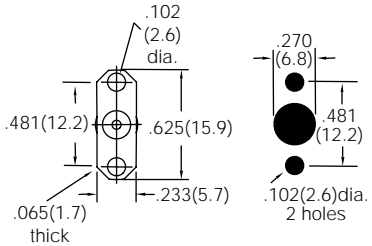
<p>Fig. 1</p>    <p style="text-align: center;">.223" Wide 2-Hole Trimline Flange</p> <p style="text-align: center;">SMA Panel Jack Receptacles Slot Terminal 901-9244-1 ‡ Gold Plated 901-9244-1SF ‡ Passivated Finish</p>	<p>Fig. 2</p>    <p style="text-align: center;">.223" Wide 2-Hole Trimline Flange</p> <p style="text-align: center;">SMA Panel Jack Receptacles Socket Terminal 901-9814 Flush TFE, Conductive Epoxy Cap 901-9770 .185 Exposed TFE</p>
--	--

SMA PANEL RECEPTACLES – 2-hole trimline flange



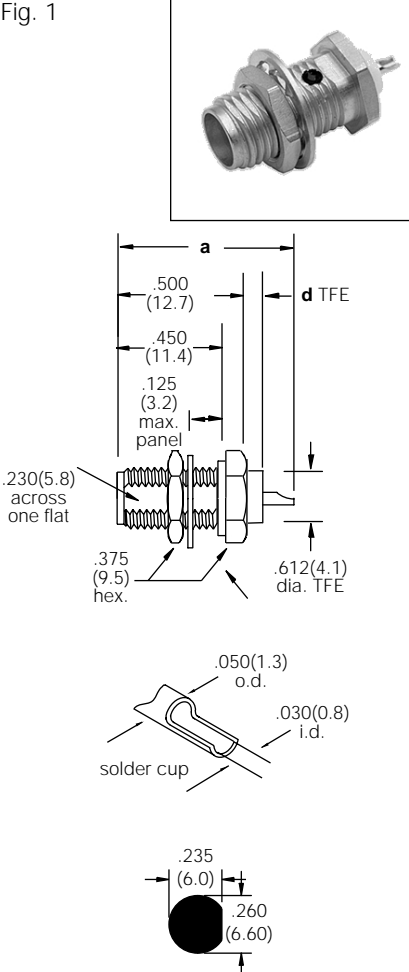
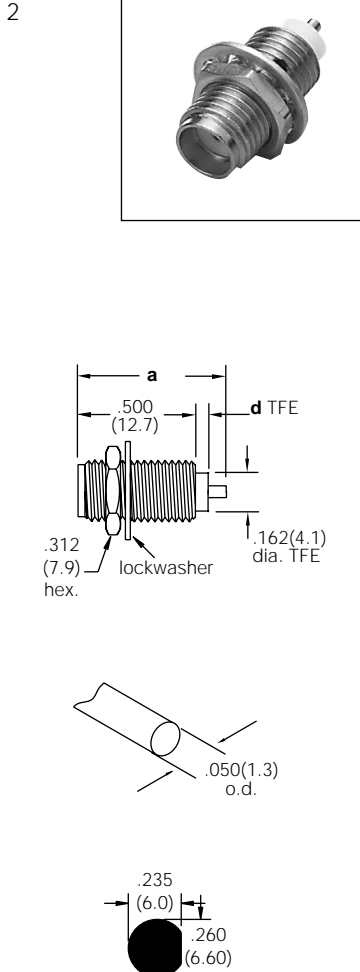
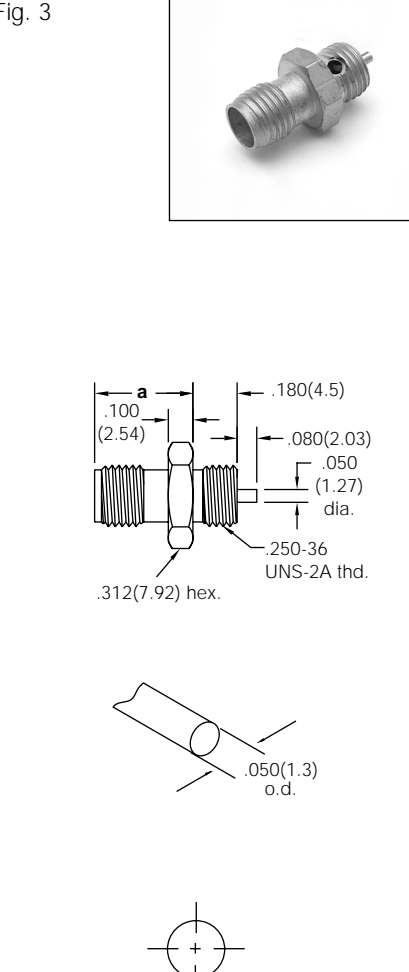

Description	Terminal Type	Plt.	Ins.	Construction Notes		Amphenol Number	Fig.
Panel Jack Receptacle	Slot .025" (0.6mm) wide	P9	D1	Contact Shipped Unassembled/ .025" (0.6 mm) Exposed TFE	Gold Plated	‡ 901-9244-1	1
		P13	D1		Passivated	‡ 901-9244-1SF	1
Panel Jack Receptacle	Socket	P13	D1	Flush TFE	Passivated Body	901-9814	2
Panel Jack Receptacle	Socket	P13	D1	.085 Exposed TFE	Passivated Body	901-9770	2

‡ Contact shipped unassembled. User has option for slot orientation

<p>Fig. 1</p>  <p>SMA Bulkhead Receptacle Rear Mount Solder Cup Terminal Hex Flange 901-9211 Gold Plated, Epoxy Captivated 901-9211-SF Passivated Finish, Epoxy Captivated 901-10032-SF Gold Plated, Mechanically Captivated 901-10032 Passivated Finish, Mechanically Captivated</p>	<p>Fig. 2</p>  <p>SMA Bulkhead Receptacle Front or Rear Mount Blunt Post Terminal 901-9220 Gold Plated 901-9220-SF Passivated Finish 901-9835 Gold Plated/Flush TFE</p>	<p>Fig. 3</p>  <p>SMA Bulkhead Receptacle Front Mount Post Terminal Hex Flange 901-9841 Gold Plated without Nut & Washer</p>
---	---	---

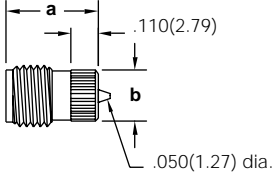
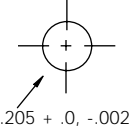

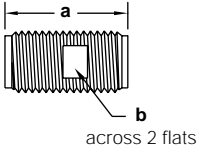
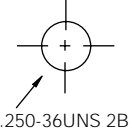

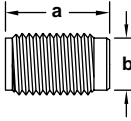
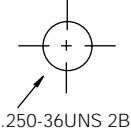
SMA BULKHEAD RECEPTACLES – female contacts

Description	Terminal Type	Plt.	Ins.	Construction Notes		Dim Inches (mm)		Amphenol Number	Fig.
						a	d		
Rear Mount/ Hex Flange	Solder Cup	P10	D1	Captive Contact/ .066(1.7mm) Exposed TFE	Gold Plated	.668(17.0)	.066(1.7)	901-9211	1
	Solder Cup	P13	D1		Passivated	.668(17.0)	.066(1.7)	901-9211-SF	1
Front or Rear Mount	Blunt Post	P10	D1	Captive Contact/ .076(1.9mm) Exposed TFE	Gold Plated	.660(16.7)	.076(1.9)	901-9220	2
	Blunt Post	P13	D1		Passivated	.660(16.7)	.076(1.9)	901-9220-SF	2
	Blunt Post	P11	D1	Captive Contact/Flush TFE	Gold Plated	.625(15.9)	.076(1.9)	901-9835	2
Front Mount	Post	P11	D1	Flush TFE	Gold Plated	.400(10.2)	—	901-9841	3
Rear Mount Hex. Flange	Solder Cup	P10	D1	Mechanically captivated	Gold Plated	.668(17.0)	.066(1.7)	901-10032	1
	Solder Cup	P13	D1	Mechanically captivated	Passivated	.668(17.0)	.066(1.7)	901-10032-SF	1

<p>Fig. 1</p>    <p>SMA Bulkhead Receptacle (Plug) Press-Fit Mount 901-9856</p>	<p>Fig. 2</p>    <p>SMA Bulkhead Receptacle (Jack) 901-9847</p>	<p>Fig. 3</p>    <p>SMA Launcher 901-9023</p>
---	--	---



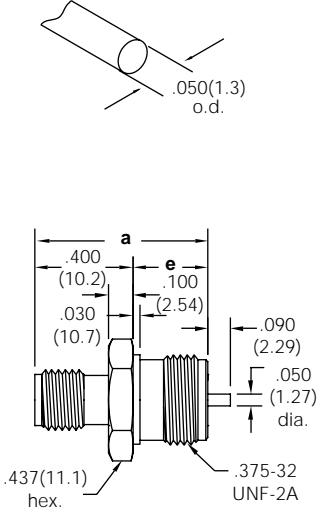
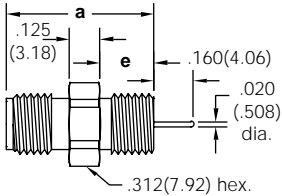
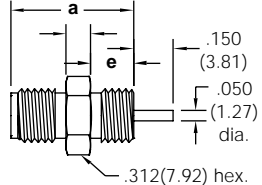
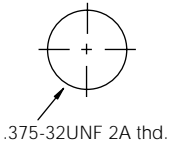
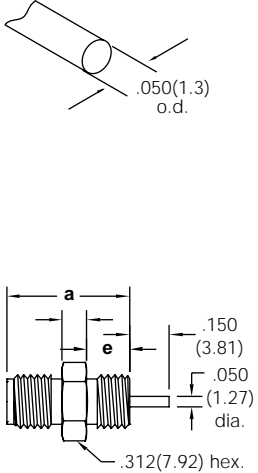

SMA BULKHEAD RECEPTACLES – female contacts

Description	Terminal Type	Plt.	Ins.	Construction Notes		Dim Inches (mm)		Amphenol Number	Fig.
						a	b		
Press-Fit	Tab	P13	D1	Flush TFE	Passivated	.375(9.53)	.206(5.23)	901-9856	1
Front or Rear Mount	Socket	P13	D1	Flush TFE	Passivated	.500(12.7)	.210(5.33)	901-9847	2
	Socket	P13	D1	Flush TFE/ w/o Nut & Washer	Passivated	.425(10.8)	.210(5.33)	901-9023	3

<p>Fig. 1</p> 	<p>Fig. 2</p> 	<p>Fig. 3</p> 
		
 <p>.375-32UNF 2A thd.</p>	 <p>.250-36UNS 2B</p>	 <p>.250-36UNS 2B</p>
<p>SMA Mid-Flange Bulkhead Receptacle Front Mount Post Terminal 901-9842</p>	<p>SMA Mid-Flange Bulkhead Receptacle Front Mount Post Terminal 901-9909</p>	<p>SMA Mid-Flange Bulkhead Receptacle Front Mount Post Terminal 901-9911</p>

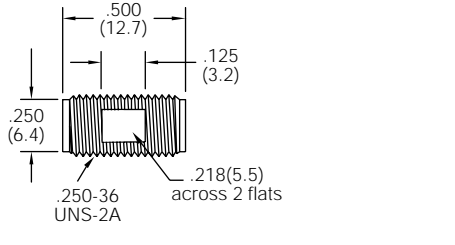

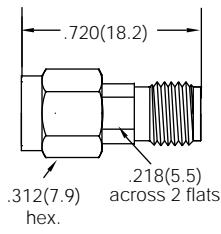
SMA MID-FLANGE BULKHEAD RECEPTACLES – female contacts

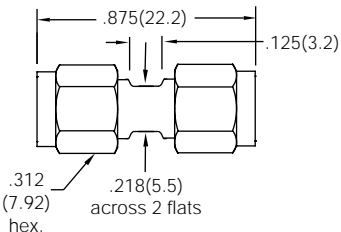
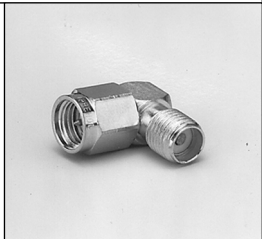
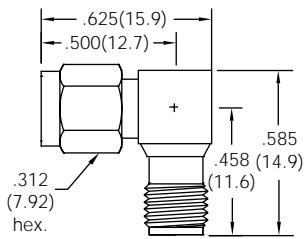
Description	Terminal Type	Plt.	Ins.	Construction Notes		Dim Inches (mm)		Amphenol Number	Fig.
						a	e		
Front Mount	Blunt Post	P13	D1	Flush TFE	Passivated	.706(17.9)	.306(7.77)	901-9842	1
Front Mount	Blunt Post	P13	D1	.020 Spherical Radius	Passivated	.600(15.2)	.220(5.89)	901-9909	2
Front Mount	Blunt Post	P12	D1	Gold over Copper Contact	Passivated	.500(12.7)	.188(4.78)	901-9911	3

<p>Fig. 1</p> <p>DC-18 GHz 1.14 VSWR max.</p>   <p>SMA Straight Adapter, Jack-Jack 901-9217 Gold Plated 901-9217-SF Passivated Finish</p>	<p>Fig. 2</p> <p>DC-18 GHz 1.14 VSWR max.</p>   <p>SMA Straight Adapter, Plug-Jack 901-9216 Gold Plated 901-9216-SF Passivated Finish</p>
<p>Fig. 3</p> <p>DC-18 GHz 1.14 VSWR max.</p>   <p>SMA Straight Adapter, Plug-Plug 901-9218 Gold Plated 901-9218-SF Passivated Finish</p>	<p>Fig. 4</p> <p>DC-18 GHz 1.23 VSWR max.</p>   <p>SMA Angle Adapter, Plug-Jack 901-125-11 Gold Plated 901-125-11SF (M55339/02-30001) Passivated</p>

SMA IN-SERIES ADAPTERS

Description	Plt.	Ins	Notes	Mil. No. M55339/	Amphenol Number	Fig.
Straight Jack-Jack	P9	D1	DC-18GHz Max. VSWR 1.14 Captive Contact	Gold Plated	—	901-9217
	P12			Passivated	—	901-9217-SF
Straight Plug-Jack	P9	D1	DC-18GHz Max. VSWR 1.14 Captive Contact	Gold Plated	—	901-9216
	P12			Passivated	—	901-9216-SF
Straight Plug-Plug	P10	D1	DC-18GHz Max. VSWR 1.14 Captive Contact	Gold Plated	—	901-9218
	P12			Passivated	—	901-9218-SF
Angle Plug-Jack	P13	D1	DC-18GHz Max. VSWR 1.23 Captive Contact	Gold Plated	—	901-125-11
	P13			Passivated	02-30001	901-125-11SF

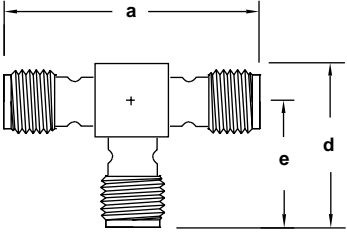
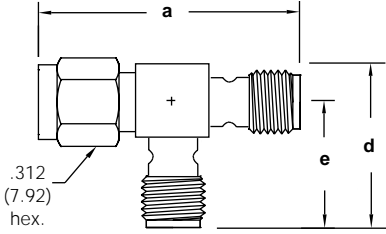
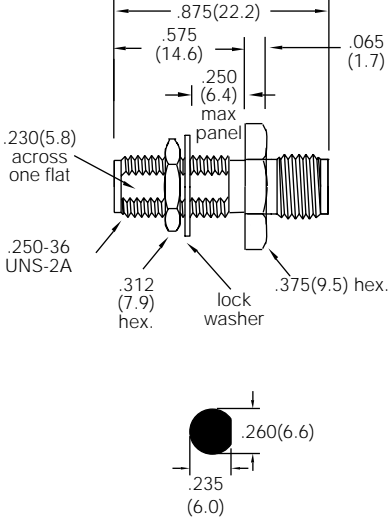
<p>Fig. 1</p> 	<p>Fig. 2</p> 	<p>Fig. 3</p> 
 <p>SMA Tee Adapter Jack-Jack-Jack 901-178 Gold Plated</p>	 <p>SMA Tee Adapter Plug-Jack-Jack 901-382-1 Gold Plated</p>	 <p>SMA Bulkhead Adapter Jack-Jack 901-9209-A Gold Plated 901-9209-ASF Passivated Finish</p>

SMA IN-SERIES TEE ADAPTERS

Description	Dimensions, Inches (millimeters)			Plt.	Ins	Notes	Amphenol Number	Fig.
	a	d	e					
Tee Adapter, Jack-Jack-Jack	1.00(25.4)	.687(17.5)	.500(12.7)	P9	D1	BeCu Body	901-178	1
Tee Adapter, Plug-Jack-Jack	1.08(27.4)	.687(17.5)	.500(12.7)	P9	D1	BeCu Body	901-382-1	2

SMA IN-SERIES BULKHEAD ADAPTERS

Description	Plt.	Ins	Notes	Amphenol Number	Fig.
Bulkhead Jack-Jack Front or Rear Mount	P11	D1	DC-18GHz Max. VSWR 1.14 Captive Contact	901-9209-A	3
	P13			901-9209-ASF	

Amphenol has available a line of 50 ohm SMA brass connectors as a cost effective solution for applications where stainless steel construction is not required. This gives the design engineer flexibility with performance to complete projects with world class components.

Amphenol series 901 SMA brass connectors are semi-precision, subminiature units which provide electrical performance from DC to 18 GHz. These high performance connectors are compact in size and mechanically have outstanding durability.

Features/Benefits

- Amphenol brass SMA connectors feature pre-assembled captive center contacts, brass body and coupling nuts.
- Connectors are built in accordance with MIL-C-39012.
- Can be mated with all connectors which meet the military specification mating diameters regardless of manufacturer.
- Available for .085" and .141" diameter semi-rigid cables and all the standard flexible cables including double shielded RG-316.
- Connectors are adaptable to the interconnection requirements of both systems and components.

SPECIFICATIONS*

ELECTRICAL

Impedance	50 ohms
Frequency range	.141" & .085" O.D. copper jacket semi-rigid cable. 0-18GHz. Flexible cables: 0-12.4 GHz.
Voltage rating	RG-58,141,142: 500 volts peak RG-174, 188, 316:, 375 volts peak
Dielectric withstanding voltage	.141" & RG-58 group: 1,000 VRMS. .085" & RG-316 group: 750 VRMS.
VSWR (straight connectors)	.141" O.D. semi-rigid cable: 1.05 + .005 f RG-174 group: 1.15 + .02 f RG-58 group: 1.15 + .01 f RG-178 group: 1.20 + .025 f
Contact resistance	Center: 2.0 milliohms Body: 2.0 milliohms Braid to body: 0.5 milliohms
Insulation resistance:	5000 megohms
RF leakage	-90 dB min. at 2.3 GHz
Insertion loss:	dB max. = $.06 \sqrt{f(\text{GHz})}$ Test frequency @ 6.0 GHz

MATERIAL



Bodies, coupling nuts, other metal parts (except as noted)	Brass per QQ-B-626
Contacts Male: Female:	Brass Beryllium copper, heat treated
Plating: Center contacts,	.000030" min. gold
Plating: Other metal parts	Standard .000010" gold or nickel plated
Insulators	TFE fluorocarbon
Gaskets	Silicone rubber
Crimp ferrules	Seamless copper tubing alloy

MECHANICAL†

Mating	.250-36 Threaded coupling
Mating Torque	Minimum: 2 inch pounds 12 N.cm Recommended: 8 to 10 inch pounds 45 N.cm Maximum: 15 inch pounds 60 N.cm
Connector Durability	100 matings

* These characteristics are typical and may not apply to all connectors.

† Pressure applied on an SMA outer contact is extremely high; therefore inadequate torque of connector body will result in a slight deformation of the outer contact. Reflections will appear above 2GHz.

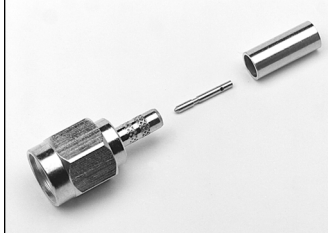
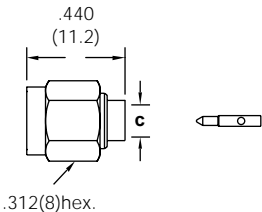
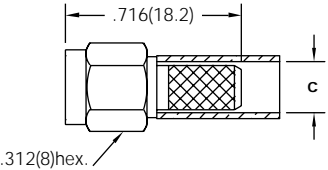
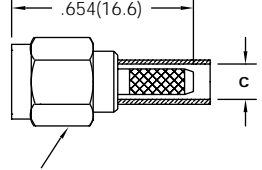
<p>Fig. 1</p> 	<p>Fig. 2</p> 	<p>Fig. 3</p> 
 <p>.440 (11.2)</p> <p>.312(8)hex.</p> <p>c</p> <p>SMA Solder Plug 901-9868-RFX▲ Gold Plated for .141" S/R 901-9867-RFX▲ Gold Plated for .085" S/R</p>	 <p>.716(18.2)</p> <p>.312(8)hex.</p> <p>c</p> <p>SMA Crimp Plug Captivated Center Contact 901-9870▲ Gold Plated for RG-58 901-9871▲ Gold Plated for RG-223, 141 901-9876-RFX▲ Nickel Plated for RG-58 901-10009-RFX Gold Plated for LMR 240 901-10010-RFX Gold Plated for LMR 200</p>	 <p>.654(16.6)</p> <p>.312(8)hex.</p> <p>c</p> <p>SMA Crimp Plug Captivated Center Contact 901-9877-RFX▲ Nickel Plated for RG-174, 188, 316 901-9916 Gold Plated for RG-174, 188, 316 901-10024-RFX Nickel Plated for RD-174, 188, 316 901-10025-RFX Gold Plated for RD-174, 188, 316</p>

SMA BRASS PLUGS

Cable RG-/U	Connector Description	Cable Attachment		c Dia In. (mm)	CAI	Ins.	Notes	Amphenol Number	Fig.
		Outer	Inner						
58	Plug	Crimp	Solder	.210(5.3)	C53	D1	Captive Contact	▲ 901-9870	2
58	Plug	Crimp	Solder	.210(5.3)	C53	D1	Captive Contact	▲ 901-9876-RFX	2
174, 188, 316	Plug	Crimp	Solder	.128(3.3)	C57	D1	Captive Contact	▲ 901-9877-RFX	3
RD 174, 188, 316	Plug	Crimp	Solder	.128(3.3)	C57	D1	Captive Contact	901-9916	3
RD 174, 188, 316	Plug	Crimp	Solder	.128(3.3)	C57	D1	Captive Contact	901-10024-RFX	3
174, 188, 316	Plug	Crimp	Solder	.128(3.3)	C57	D1	Captive Contact	901-10025-RFX	3
141, 223	Plug	Crimp	Solder	.220(5.6)	C53	D1	Captive Contact	▲ 901-9871	2
.085" S/R	Plug	Solder	Solder	.090(2.3)	C47	D1	—	▲ 901-9867-RFX	1
.141" S/R	Plug	Solder	Solder	.145(3.7)	C47	D1	—	▲ 901-9868-RFX	1
LMR 240	Plug	Crimp	Solder	.261(6.6)	C53	D1	Captive Contact	901-10009-RFX	2
LMR 200	Plug	Crimp	Solder	.206(5.2)	C53	D1	Captive Contact	901-10010-RFX	2

▲ distributor stocked

SMA Brass Angle Plugs & Bulkhead Jacks

Fig. 1

SMA Angle Plug, Crimp
901-9872▲
 Gold Plated for RG-174, 188, 316
901-9873▲
 Gold Plated for RG-58
901-9874▲
 Gold Plated for RG-141, 223
901-9880-RFX▲
 Nickel Plated for RG-58
901-9881-RFX▲
 Nickel Plated for RG-174, 188, 316
901-10028-RFX
 Gold Plated for RD-174, 188, 316
901-10029-RFX
 Nickel Plated for RD-174, 188, 316

Fig. 2

SMA Low Profile Angle Plug, Crimp
901-9902
 Nickel Plated for RG-141, 223

Fig. 3

SMA Bulkhead Jack, Crimp
901-9875▲
 Gold Plated for RG-174, 188, 316
901-9879-RFX▲
 Nickel Plated for RG-174, 188, 316

Fig. 4

SMA Bulkhead Jack with O-Ring
901-10013-RFX
 RG-174, 188, 316

SMA BRASS ANGLE PLUGS

Cable RG-/U	Connector Description	Cable Attachment		c Dia In. (mm)	CAI	Ins.	Notes	Amphenol Number	Fig.
		Outer	Inner						
58	Angle Plug	Crimp	Solder	.210(5.3)	C53	D1	Gold Plated Body	▲ 901-9873	1
	Angle Plug	Crimp	Solder	.210(5.3)	C53	D1	Nickel Plated Body	▲ 901-9880-RFX	1
174, 188, 316	Angle Plug	Crimp	Solder	.128(3.3)	C57	D1	Nickel Plated Body	▲ 901-9881-RFX	1
	Angle Plug	Crimp	Solder	.128(3.3)	C57	D1	Gold Plated Body	▲ 901-9872	1
	Angle Plug	Crimp	Solder	.128(3.3)	C57	D1	Gold Plated Body	901-10028-RFX	1
	Angle Plug	Crimp	Solder	.128(3.3)	C57	D1	Nickel Plated Body	901-10029-RFX	1
	Angle Plug	Crimp	Solder	.128(3.3)	C57	D1	Nickel Plated Body	901-10029-RFX	1
141, 223	Angle Plug	Crimp	Solder	.220(5.6)	C53	D1	Gold Plated Body	▲ 901-9874	1
141, 223	Low Profile Angle Plug	Crimp	Solder	.220(5.6)	C53	D1	Plated Body	901-9902	2

SMA BRASS BULKHEAD JACKS

Cable RG-/U	Connector Description	Cable Attachment		c Dia. In. (mm)	CAI	Ins.	Notes	Amphenol Number	Fig.
		Outer	Inner						
174, 188, 316	Bulkhead Jack	Crimp	Solder	.128(3.3)	C53	D1	Gold Plated Body	▲ 901-9875	3
	Bulkhead Jack	Crimp	Solder	.128(3.3)	C53	D1	Nickel Plated Body	▲ 901-9879-RFX	3
	Bulkhead Jack	Crimp	Solder	.128(3.3)	C53	D1	Nickel Plated Body	901-10013-RFX	4

▲ distributor stocked

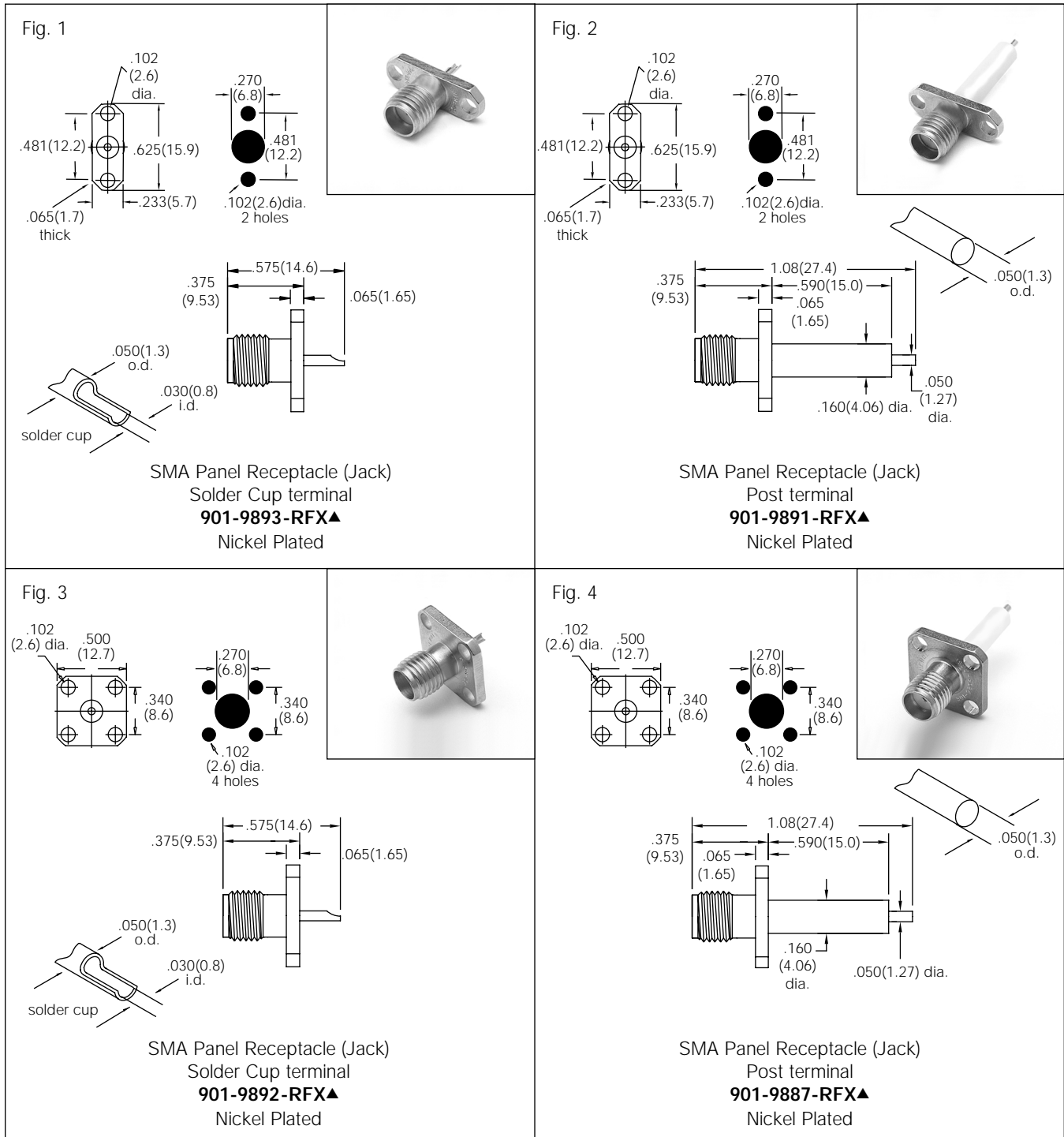

SMA BRASS PANEL JACK RECEPTACLES

Connector Description	Terminal Type	Ins	Construction Notes	Amphenol Number	Fig.
Panel Receptacle (Jack)	Solder Cup	D1	Nickel Plated Body	▲ 901-9893-RFX	1
Panel Receptacle (Jack)	Post	D1	Nickel Plated Body	▲ 901-9891-RFX	2
Panel Receptacle (Jack)	Solder Cup	D1	Nickel Plated Body	▲ 901-9892-RFX	3
Panel Receptacle (Jack)	Post	D1	Nickel Plated Body	▲ 901-9887-RFX	4

▲ distributor stocked

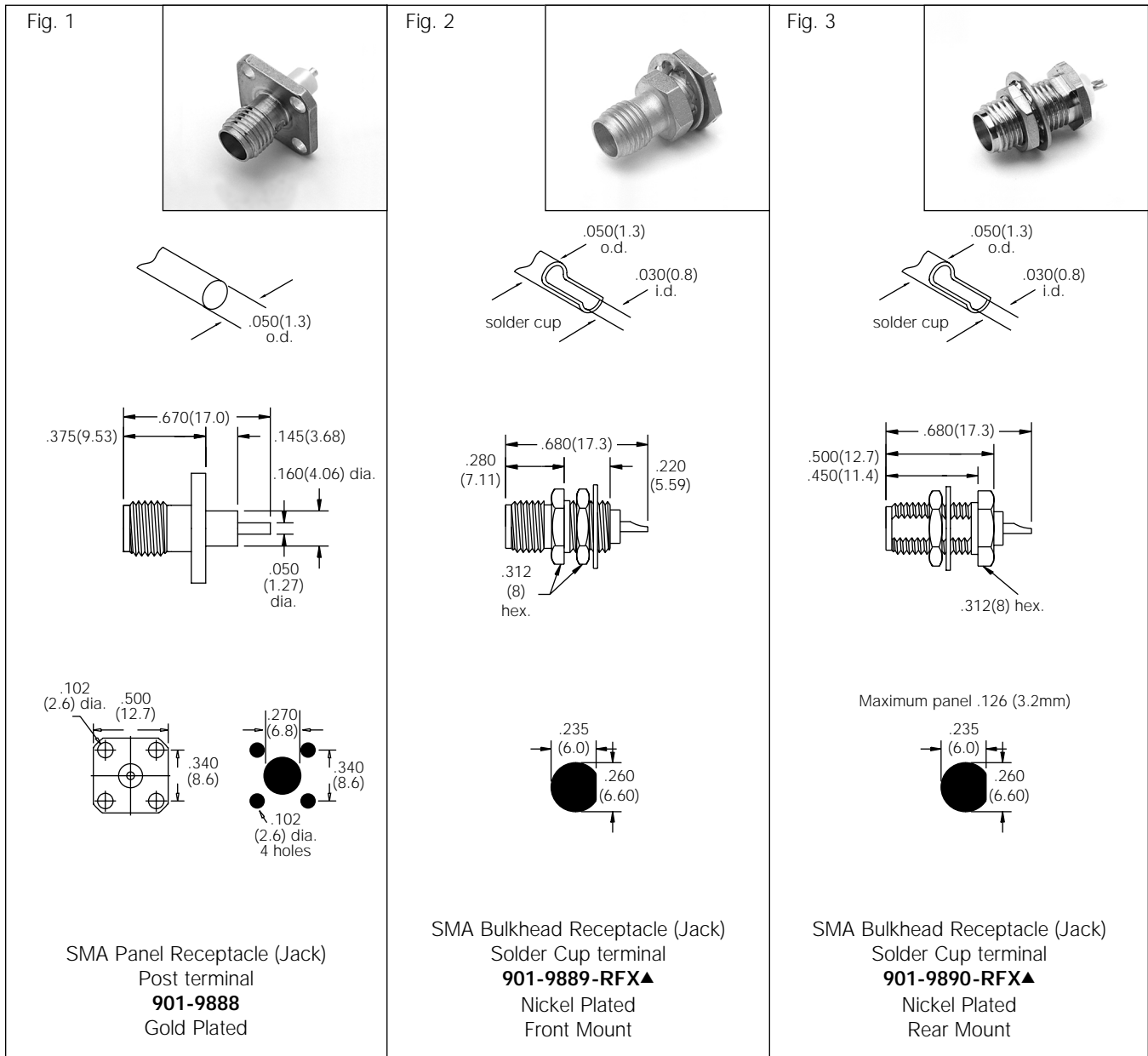

SMA BRASS PANEL JACK RECEPTACLES

Connector Description	Terminal Type	Ins	Construction Notes	Amphenol Number	Fig.
Panel Receptacle (Jack)	Post	D1	Gold Plated Body	901-9888	1

SMA BRASS BULKHEAD RECEPTACLES

Connector Description	Terminal Type	Ins	Construction Notes	Amphenol Number	Fig.
Bulkhead Receptacle (Jack), Front Mount	Solder Cup	D1	Nickel Plated Body	▲ 901-9889-RFX	2
Bulkhead Receptacle (Jack), Rear Mount	Solder Cup	D1	Nickel Plated Body	▲ 901-9890-RFX	3

▲ distributor stocked

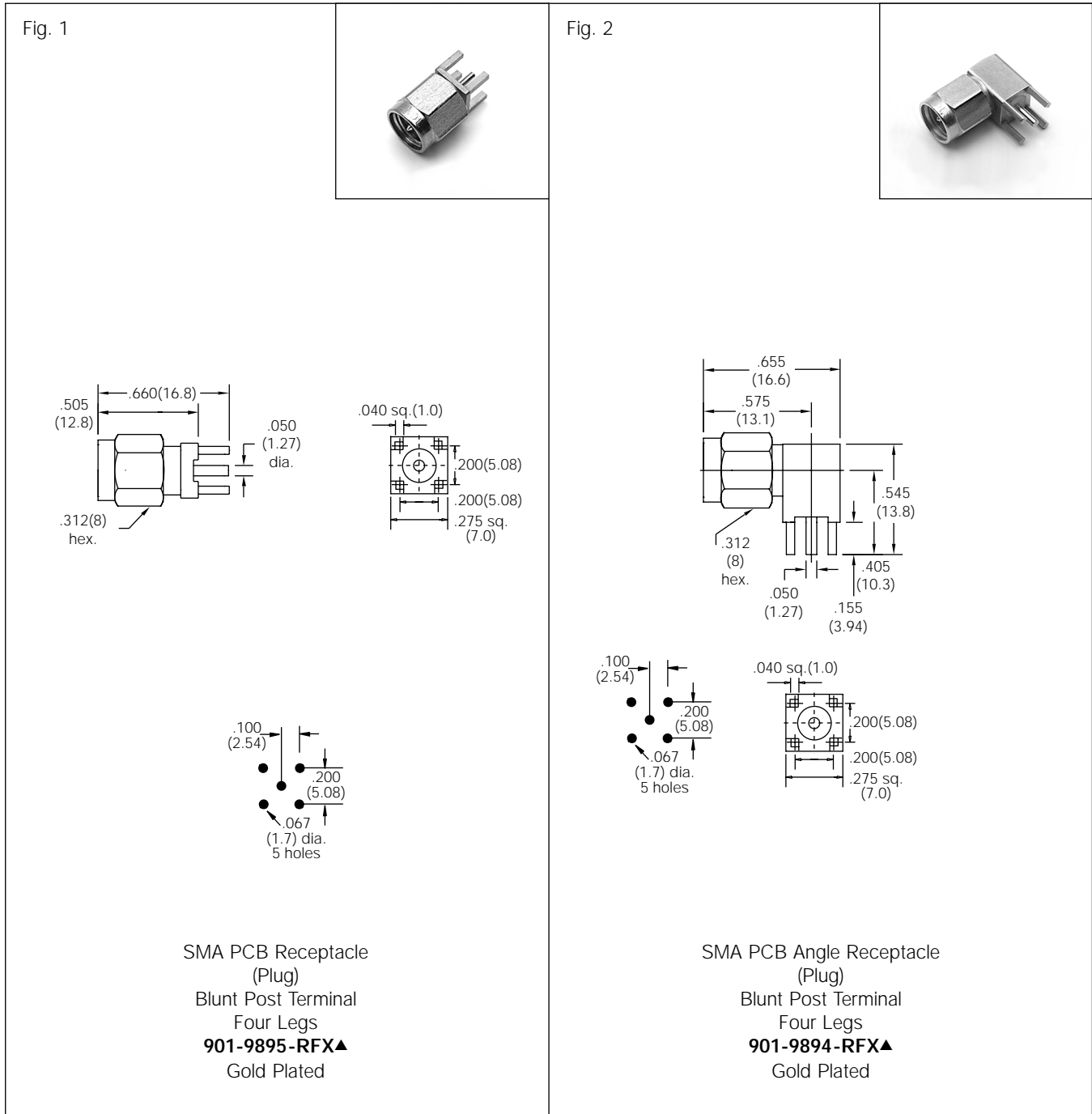

SMA BRASS PRINTED CIRCUIT BOARD PLUG RECEPTACLES

Connector Description	Terminal Type	Ins	Construction Notes	Amphenol Number	Fig.
PCB Receptacle (P)/ Four Legs	Blunt Post	D1	Gold Plated Body	▲ 901-9895-RFX	1
PCB Angle Receptacle (P)/ Four Legs	Blunt Post	D1	Gold Plated Body	▲ 901-9894-RFX	2

▲ distributor stocked

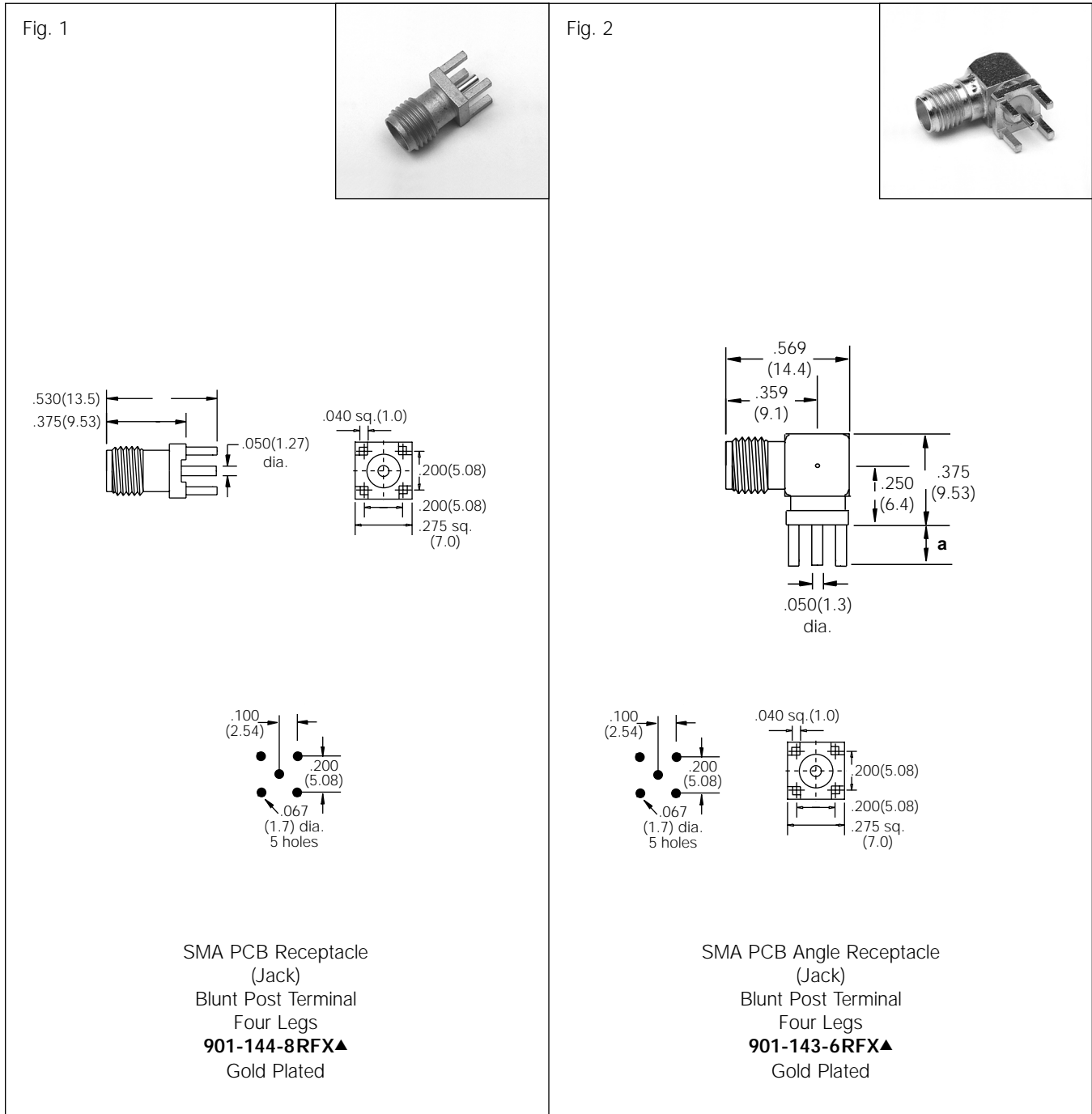

SMA BRASS PRINTED CIRCUIT BOARD JACK RECEPTACLES

Connector Description	Terminal Type	Ins	Construction Notes	Amphenol Number	Fig.
PCB Receptacle (J)/ Four Legs	Blunt Post	D1	Gold Plated Body	▲ 901-144-8RFX	1
PCB Angle Receptacle (J)/ Four Legs	Blunt Post	D1	Gold Plated Body	▲ 901-143-6RFX	2

▲ distributor stocked

For phase array radar, test equipment, ILS landing systems and other instrumentation using phase matching techniques, these SMA connectors for semi-rigid coaxial cables and the SMA plug-to-Jack adapter offer a precise and simple means of phase adjustment for microwave devices.

Features/Benefits

- Connectors incorporate a threaded interconnection of variable length.
- Adjustment nut creates incremental changes in connector length and angle.
- Proper phase setting for each cable is maintained by connector locking-nuts.
(For example, one revolution of the adjustment nut results in a phase angle change of 5.7° for a 9 GHz signal [0.636 x 9]°.)
- Connectors provide ease of mechanical screw adjustments, compared to the delays and expense of laborious cable-trimming.
- Allow phase matching to be performed at the final production stages.

SPECIFICATIONS*

ELECTRICAL

Impedance	50 ohms
Frequency range	DC-18GHz.
Insertion loss:	dB max. For Adapter 901-508 = $.1 \sqrt{f(\text{GHz})}$ For Plug 901-509 = $.08 \sqrt{f(\text{GHz})}$
VSWR	See chart below
Phase Angle Adjustment Range in degrees	For Adapter 901-508 and Plug 901-509, = 0° to $[10 \times f(\text{GHz})]^\circ$ max
Phase Angle change per revolution of Adjustment Nut in degrees	For Adapter 901-508 and Plug 901-509, = $[0.636 \times f(\text{GHz})]^\circ$
Voltage rating	500 VRMS peak

MECHANICAL

Mating	Mating face dimensions compatible with the mating requirements of MIL-C-39012/55 (Type SMA)
Connector Durability	(SMA interface) 500 cycles of mating and unmating without deterioration

MATERIAL

Center Contact	Beryllium copper, Gold plated
Connector Body	Brass or Beryllium Copper, Gold plated
Adjusting Nuts and Locking Nuts	Brass with ASTRO plate finish
Connector Coupling Nut	Stainless Steel, Passivated
Insulation	TFE

SWEPT VSWR DATA

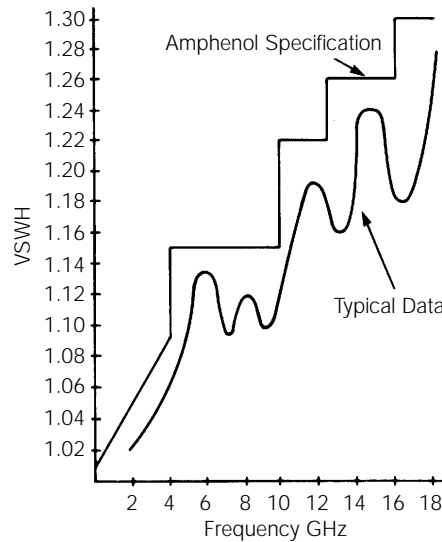

ENVIRONMENTAL

Shock	MIL-Std. 202 method 213 (test cond. I)
Vibration	MIL-Std. 202 method 204 (test cond. D)
Corrosion	MIL-Std. 202 method 101 (test cond. B)
Temperature range	-65°C to + 125°C

* These characteristics are typical and may not apply to all connectors.