

Ultra-Broadband Silicon Capacitor UBSC 0201M 22nF BV11



Rev. 2.00

General description

UBSC Capacitor targets Optical communication system such as ROSA/TOSA, SONET and all optoelectronics as well as High speed data system or products. The UBSC is suitable for DC blocking, feedback, coupling and bypassing applications in all broadband optoelectronics and High-speed data system. The unique technology of integrated passive device in silicon, developed by Murata Integrated Passive Solutions, offers best in class performances with low insertion loss, low reflection and phase stability from 73 KHz to 60 GHz+.

These capacitors in ultra-deep trenches in silicon have been developed in a semiconductor process, in order to integrate trench MOS capacitor providing high capacitance value of 22 nF (for kHz–MHz range) and high frequency MIM capacitors for low capacitance value for GHz range), combined in a 0201M [0.6x0.3mm] case.

The UBSC capacitor provides very high stability of the capacitance over temperature, voltage variation as well as a very high reliability.

UBSC capacitors have an extended operating temperature ranging from -55 to 150°C, with very low capacitance change over temperature.

Assembly: Suitable for surface mounted application on rigid PCB, ceramic substrate, FR4 (laminated) or flex platforms.

Bump finishing: SAC305 type 6.

Copper pads optional for embedding version and ENIG for un-bumped version, as an optional finishing.

Key features

- Ultra-Broadband performance up to 67 GHz
- Resonance free
- Phase stability
- Insertion loss < 0.4dB Typ. up to 60 GHz
- Ultra-high stability of capacitance value:
 - Temperature 70ppm/K (-55 °C to +150 °C)
 - Voltage < -0.1%/Volt
 - Negligible capacitance loss through ageing
- Low profile: 140 μm including bump height (SAC305 40μm bumps after reflow)
- Break down voltage : 11V
- Low leakage current < 100pA
- High reliability
- High operating temperature (up to 150 °C)
- Compatible with high temperature cycling during manufacturing operations (exceeding 300 °C)
- Compatible with EIA 01005 footprint and with EIA 0201 outline

Key applications

- ROSA/TOSA
- SONET
- High speed digital logic
- Microwave/millimetre system
- High volumetric efficiency (*i.e. capacitance per unit volume*)
- Broadband test equipment



Functional diagram

The next figure provides implementation set-up diagram.

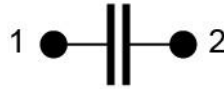

Figure 1 Block Diagram

Electrical performances

Symbol	Parameter	Conditions	Min.	Typ.	Max.	Unit
C	Capacitance value	@+25°C	-	22	-	nF
ΔC_P	Capacitance tolerance ⁽¹⁾	@+25°C	-15	-	+15	%
T _{OP}	Operating temperature		-55	20	150	°C
T _{STG}	Storage temperature ⁽²⁾		-70	-	165	°C
ΔC_T	Capacitance temperature variation	-55 °C to 150 °C	-	70	-	ppm/K
RV _{DC}	Rated voltage ⁽³⁾		-	-	3.8 ⁽⁴⁾ 3.4 ⁽⁵⁾	V _{DC}
BV	Break down voltage	@+25°C	11	-	-	V
ΔC_{RVDC}	Capacitance voltage variation	From 0 V to RV _{DC} , @+25°C	-	-	-0.1	%/V _{DC}
IR	Insulation resistor	@RV _{DC} , +25°C, 120s	-	10	-	GΩ
F _{C-3dB}	Cut-off frequency at 3dB	@+25°C	-	73	86	kHz
IL	Insertion loss	@ 20 GHz, +25°C	-	0.2	-	dB
		@ 40 GHz, +25°C	-	0.3	-	dB
		@ 60 GHz, +25°C	-	0.4	-	dB
RL	Return loss	Up to 60 GHz, +25°C	24	-	-	dB
ESD	HBM stress ⁽⁶⁾	JS-001-2017	2	-	-	kV

Table 1 - Electrical performances

⁽¹⁾: other tolerance available upon request.

⁽²⁾: without packaging.

⁽³⁾: Lifetime is voltage and temperature dependent, please refer to application note 'Lifetime of 3D capacitors'.

⁽⁴⁾: 10 years of intrinsic life time prediction at 100°C continuous operation.

⁽⁵⁾: 10 years of intrinsic life time prediction at 150°C continuous operation.

⁽⁶⁾: please refer to application note 'ESD Challenge in 3D Murata Integrated Passive technology'.

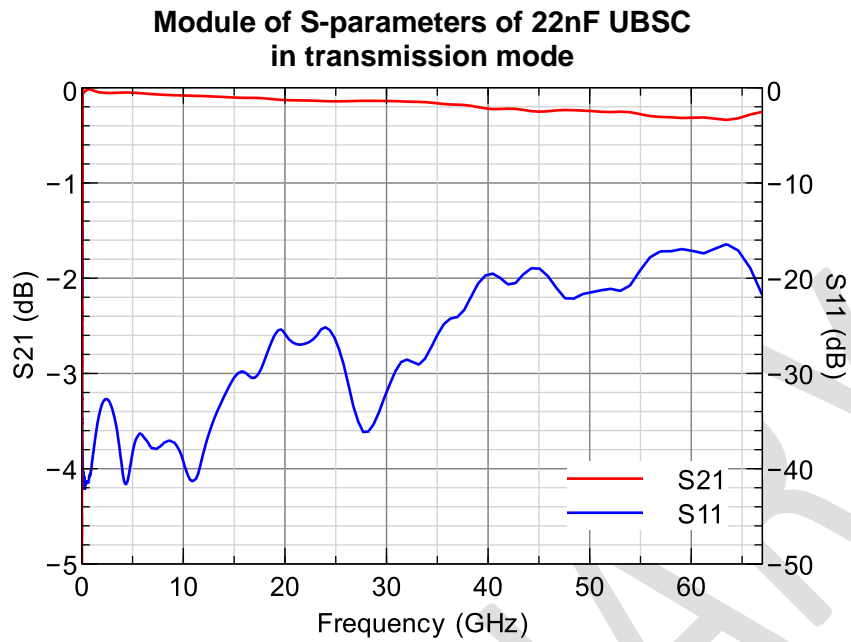
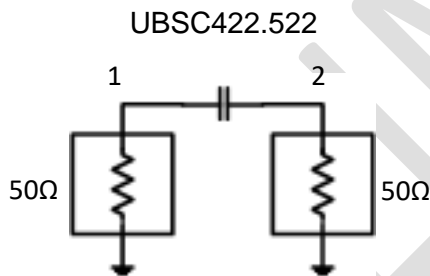

Figure 2 - 22nF UBSC measurement results (module of S-parameters)

Schematic of 22nF UBSC in transmission mode



4-mil Rogers 4350B.
Microstrip mode – line width = 0.200mm and gap = 0.200 mm.
(nominal 50 ohm characteristic impedance).

Figure 3 - 22nF UBSC measurement schematic

Example of 0201M surface mounted

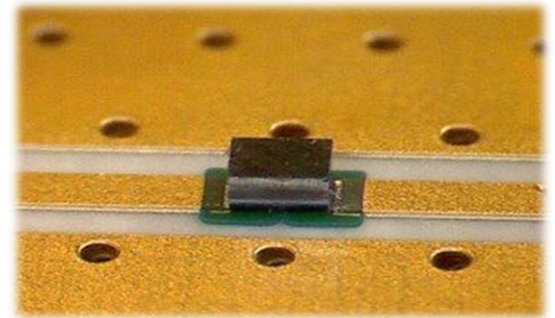

Figure 4 – micro picture of UBSC mounted on board in coplanar mode



Pinning definition

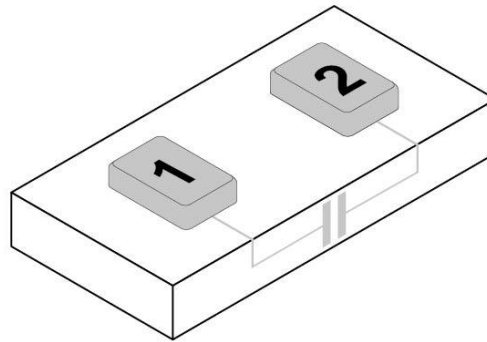

Figure 5 Pin configuration

pin #	Symbol	Coordinates X / Y
1	Signal	-150.0 / 0.0
2	Signal	150.0 / 0.0

Table 2 - Pining description. Reference (0,0) located at the centre of the die.

Ordering Information for UBSC422.522

Regardless of packaging, Murata Integrated Passive Devices delivers products with AQL level II (0.65).

Type number	Package		
	Packaging	Finishing	Description
935152422522-F1S	6" film frame carrier ⁽¹⁾	SAC ⁽²⁾	UBSC 0201M - 22nF – 2 pads – 0.6 x 0.3 x 0.10 mm ⁽⁴⁾
935152422522-T3S	7" T&R (1 000 pieces/reel) ⁽³⁾	SAC ⁽²⁾	UBSC 0201M - 22nF – 2 pads – 0.6 x 0.3 x 0.10 mm ⁽⁴⁾
935152422522-T5S	7" T&R (5 000 pieces/reel) ⁽³⁾	SAC ⁽²⁾	UBSC 0201M - 22nF – 2 pads – 0.6 x 0.3 x 0.10 mm ⁽⁴⁾
935152422522-T3N	7" T&R (1 000 pieces/reel) ⁽³⁾	ENIG ⁽²⁾	UBSC 0201M - 22nF – 2 pads – 0.6 x 0.3 x 0.10 mm ⁽⁴⁾
935152422522-T5N	7" T&R (5 000 pieces/reel) ⁽³⁾	ENIG ⁽²⁾	UBSC 0201M - 22nF – 2 pads – 0.6 x 0.3 x 0.10 mm ⁽⁴⁾

(1) Other Film Frame Carrier are possible on request

(2) SAC = ENIG + SAC305 type 6 or ENIG = 0.1µm Au / 5µm Ni

(3) missing capacitors can reach 0.5%

(4) refer to Figure 7

Table 3 - Packaging and ordering information

Product Name	Die Name	Description
UBSC422.522	XQM0201522	UBSC 22nF/0201M/BV11 – 2 pads – 0.6 x 0.3 x 0.10 mm

Table 4 - Die information



Pad Metallization

The Surface Mounted Capacitor is delivered as standard with SAC305 type6 bumping.

Other Metallization, such as ENIG (0.1 μ m Au / 5 μ m Ni), Copper, Thick Gold or Aluminum pads are possible on request.

Silicon dies are not sensitive to humidity, please refer to applications notes 'Assembly Notes' section 'Handling precautions and storage'.

Material regulation

This product is RoHS compliant at the time of publication. For further information about regulation compliancy, please ask your sales representative.

PRELIMINARY



Package outline

The product is delivered as a bare silicon die, with passivation opening for contacts.

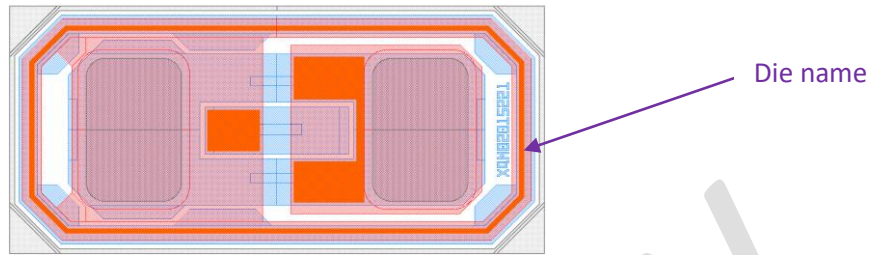

Figure 6 – Layout view

L (mm)	W (mm)	T (mm)	c (mm)	P (mm)	e (mm)	t (mm)
0.60 ±0.02	0.30 ±0.02	0.10 ±0.01	0.10	0.20	0.15	0.04 ⁽¹⁾ 0.05 ⁽²⁾ 0.005 ⁽³⁾

- (1) Solder joint height after reflow on board.
- (2) Solder bump height before assembly
- (3) only with ENIG on optional version

Table 5 - Dimensions and tolerances

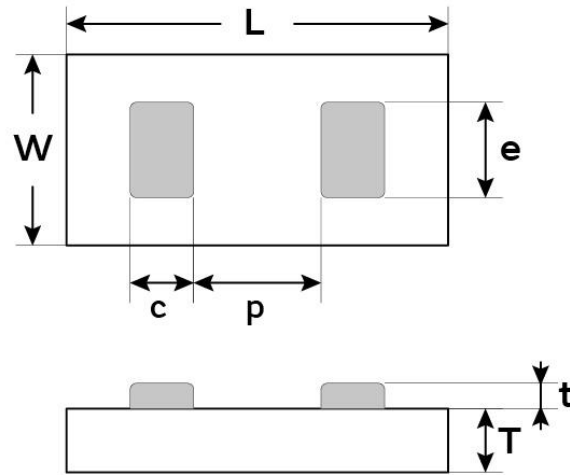

Figure 7 - Package outline drawing

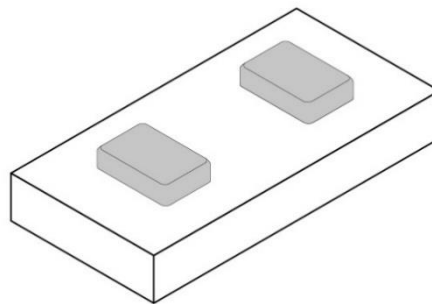

Figure 8 - Package isometric view



Assembly

UBSC series is compatible with standard reflow technology.

It is recommended to design mirror pads on the PCB.

For further information, please see our mounting application note.

The attachment techniques recommended by Murata on the customer's substrates are fully detailed in specific documents available on our website. To assure the correct use and proper functioning of Murata capacitors **please download the assembly instructions on <https://www.murata.com/en-us/products/capacitor/siliconcapacitors> and read them carefully.**



Figure 9 Scan this QR Code to access the Murata Silicon Capacitor web page

Packaging format

Please refer to application note 'Products Storage Conditions and Shelf Life'.

Tape and Reel: Dies are flipped in the tape cavity (bump down) with die ID located near the driving holes of the tape.

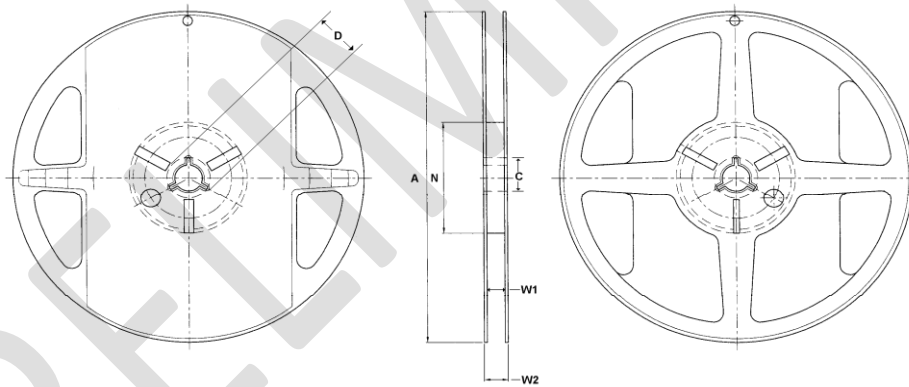

Figure 10 - Reel drawing

Tape Width	Diameter A	C	D	Hub N	W1	W2
8	178 (7 inches)	13.5	21	60	9.5	11.4

Table 6 - Reel dimensions (mm)

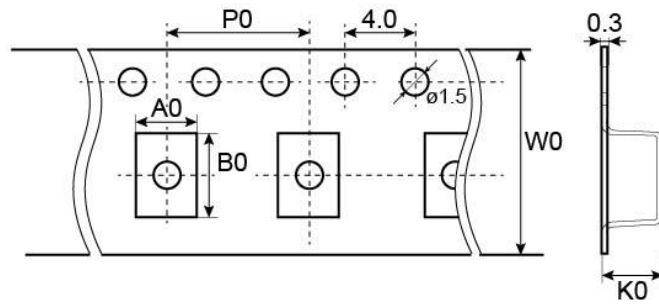

Figure 11 - Tape drawing

Cavity dimensions			Carrier tape width W0	Carrier tape pitch P0	Reel Capacity
A0 ^(*)	B0 ^(*)	K0 ^(*)			
0.37 ± 0.04	0.67 ± 0.04	0.20 ± 0.04	8.00	2.00	1000 or 5000

Table 7 - Tape dimensions (mm)



Film frame carrier:

With UV curable dicing tape (UV performed)

Good dies are identified using the SINF electronic mapping format. No ink is added on wafer to label other dies.

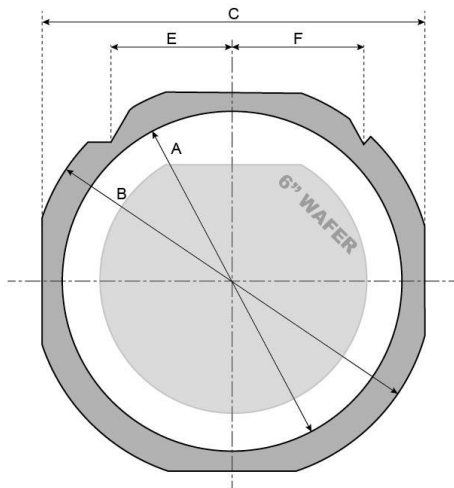

Figure 12 FF070 Frame with a 6" wafer

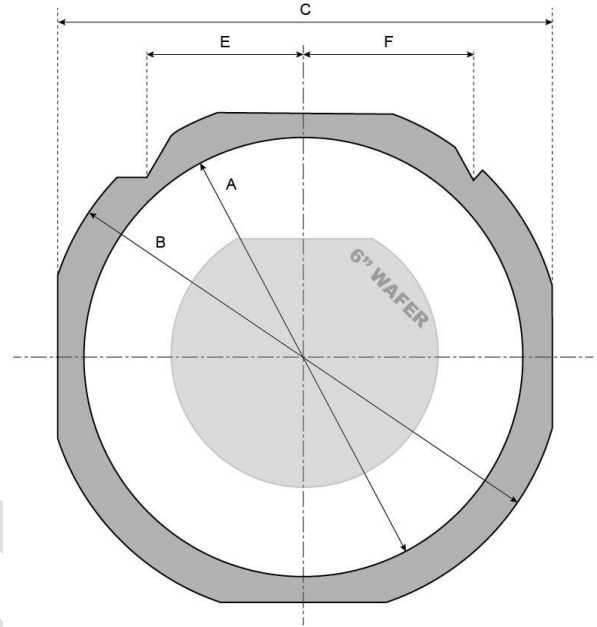

Figure 13 FF108 Frame with a 6" wafer

Frame Reference	Frame Style	Inside diameter A	Outside diameter B	Width C	Thickness	Pin location E	Pin location F
FF070 ⁽¹⁾	DTF-2-6-1	7.638"	8.976"	8.346"	0.048"	2.370"	2.5"
FF108 ⁽¹⁾	DTF-2-8-1	9.842"	11.653"	10.866"	0.048"	2.381"	2.5"

Table 8 - Frame dimensions (inches)

(1) or equivalent



Expander grip ring 6" diameter:

With UV curable dicing tape (UV performed)

Good dies are identified using the SINF electronic mapping format. No ink is added on wafer to label other dies.

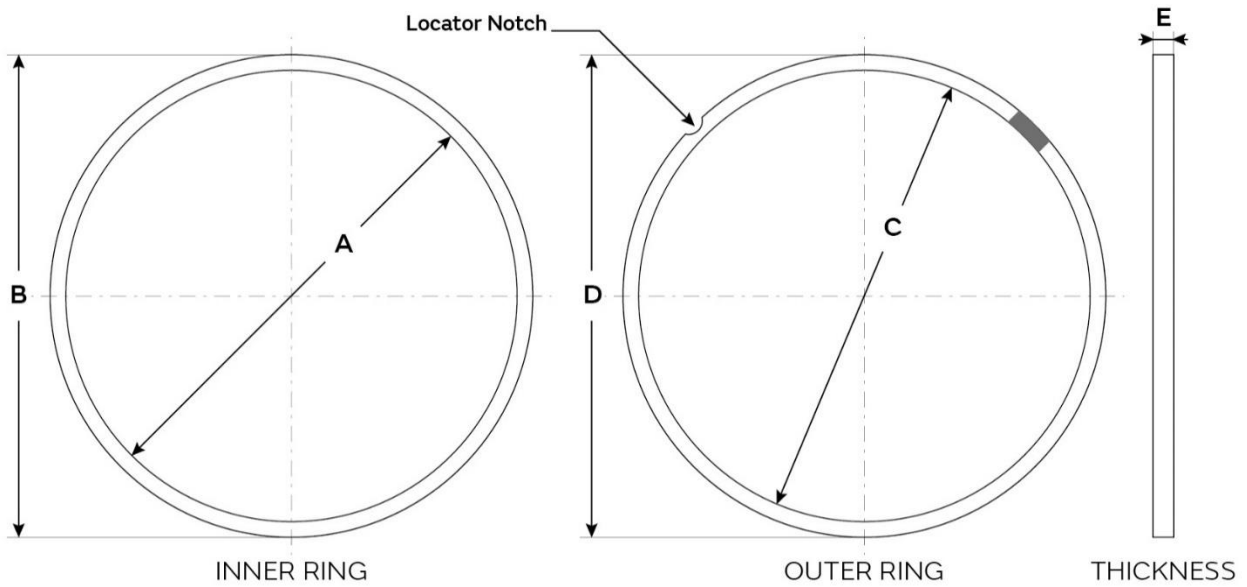

Figure 14 – Grip Ring drawing

Grip Ring Style	A	B	C	D	E	Locator Notch
GRP-2620-6 ⁽¹⁾	7.670"	7.973"	7.975"	8.280"	0.236"	None

Table 9 - Frame dimensions (inches)

(1) or equivalent