

REVISIONS			
REV.	DESCRIPTION	DATE	APPROVED
A	INITIAL RELEASE	01/07/11	M.J.

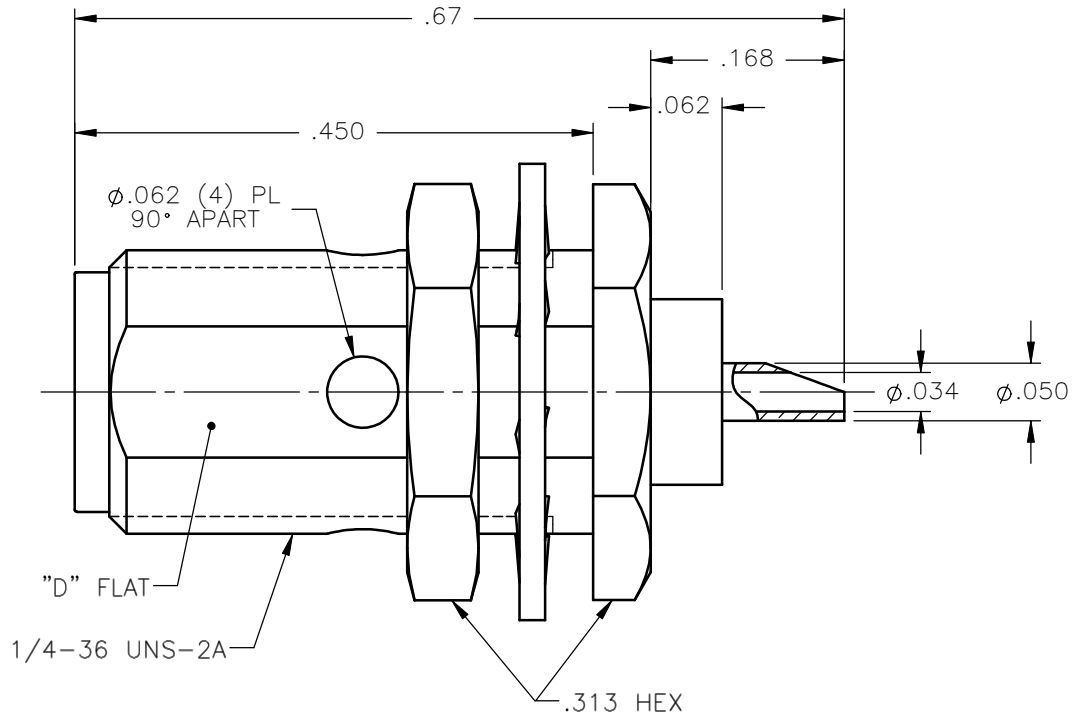

NOTES:

MATERIALS:

1. BODY & NUT = STAINLESS STEEL PER ASTM A582, ALLOY 303, CONDITION "A".
2. INSULATOR = VIRGIN WHITE TEFLON PER ASTM D1710, GRADE 1, TYPE I, CLASS "B".
3. CONTACT = BERYLLIUM COPPER PER ASTM B196, ALLOY C17300, TEMPER TD04.
4. LOCKWASHER = PHOSPHOR BRONZE PER ASTM B139, COPPER ALLOY C53400, TEMPER H04.

FINISHES:

1. BODY & NUT = PASSIVATE PER QQ-P-35, TYPE VI.
2. CONTACT = GOLD PLATE PER MIL-G-45204, TYPE II, CLASS 1, GRADE C, OVER .00010 TO .00020 STRESS FREE SULFAMATE NICKEL PER QQ-N-290.
3. LOCKWASHER = NICKEL PLATE PER QQ-N-290, CLASS 1, GRADE G, EXCEPT .0001 TO .0002 THICK OVER .00005 TO .0001 THICK COPPER PER MIL-C-14550.

UNLESS OTHERWISE SPECIFIED DIMENSIONS ARE IN INCHES TOLERANCES ON		DWN:	DATE	Property of Radiall This document cannot be reproduced or communicated to a third party without prior written permission of RADIALL.			
		M.J.	01/07/11				
DECIMAL	ANGLE	CHKD:	DATE				
		D.N.	01/07/11				
		APVD:	DATE	SMA STRAIGHT JACK BULKHEAD REAR MOUNT SOLDER POT RECEPTACLE			
		J.M.	01/07/11				
REFERENCE:		MATERIALS & FINISHES:		SIZE	FSCM NO.	DWG NO.	REV
ORIGINATED: M.J. DATE: 01/07/11		SEE NOTES		A	19505	9412-9113-000	A
				SCALE	6:1	THIRD ANGLE PROJECTION	SHEET 1 OF 1

9412-9113-000