

THIS DOCUMENT IS THE PROPERTY OF
KEYSTONE ELECTRONICS CORP. AND
SHALL NOT BE REPRODUCED, DISTRIBUTED
OR USED AS A BASIS FOR MANUFACTURE
WITHOUT PRIOR WRITTEN PERMISSION
FROM KEYSTONE ELECTRONICS CORP.

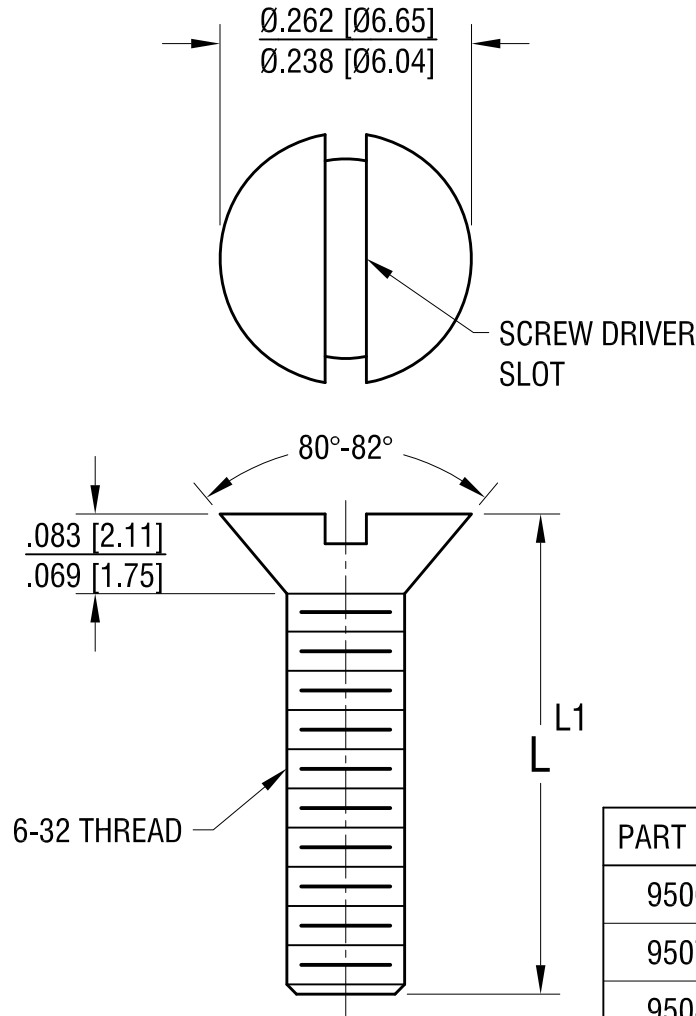

ACTUAL SIZE

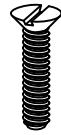

P/N 9510

PART NO.	'L' DIM.	'L1' TOL. +0.0
9506	.187 [4.75]	-.020 [-0.50]
9507	.250 [6.25]	
9508	.375 [9.53]	
9509	.500 [12.70]	
9510	.625 [15.88]	-.030 [-0.76]
9511	.750 [19.05]	
9512	1.000 [25.40]	
9513	1.250 [31.75]	-.060 [-1.52]
9514	2.000 [50.80]	

KEYSTONE ELECTRONICS CORP.

www.keyelco.com • NEW HYDE PARK NY 11040 • Tel (516)328-7500

PART NAME		6-32 FLAT HEAD SCREW	
MATERIAL		STEEL	
FINISH		DRN BY	DATE
ZINC PLATE		BOONE	3.01.04
		APP'D	SCALE
		RH	5X
TOLERANCES	INCH [MM]	CODE	DWG NO.
DECIMAL	± .017 [± 0.43]	C	9506-9514
ANGULAR	± 1°		
UNLESS OTHERWISE SPECIFIED			

2.10.22	TO MATCH ASTM SPEC. CHANGE AS PER ECN 22-035	A
DATE	DESCRIPTION	REV.