



MODEL NO. : TMS150XG1-10TB

ISSUED DATE: 2011-03-04

VERSION : 1.3

- Preliminary Specification
- Final Product Specification

Customer : _____

Approved by	Notes

SHANGHAI AVIC Confirmed :

Prepared by	Checked by	Approved by
Wei Zhang	JiaXiang Du	XiaoPing Sun

This technical specification is subjected to change without notice



INTRODUCTION

• WARRANTY

Shanghai AVIC OPTOELECTRONICS Co. Ltd (hereinafter called "AVIC") warrants that this product meets the product specifications set forth in this document. If this product under normal operation is found to be non-conforming to the product specifications, and such non-conformance is promptly notified to AVIC within one (1) year after the delivery date, and further such non-conformance is solely attributable to AVIC, AVIC shall repair the non-conforming product or replace it with a conforming one, free of charge. However, this warranty does not apply to any non-conformance that can be found easily by incoming inspections or those resulting from any one of the following:

- 1) Unauthorized or improper repair, maintenance or modification
- 2) Operation or use against specifications, instructions or warnings given by AVIC
- 3) Any other causes attributable to customer

In case AVIC repairs or replaces a product after the one (1)-year warranty period, AVIC shall be entitled to charge for such repair or replacement. Those replaced parts shall be covered with six (6)-month warranty period from the replacement day. Non-conforming products may be replaced with substitutes instead of repair when the manufacture of this product has been terminated.

EXCEPT AS EXPRESSLY SET FORTH HEREIN, AVIC DISCLAIMS ANY WARRANTIES, EXPRESS OR IMPLIED, INCLUDING BUT NOT LIMITED TO MERCHANTABILITY AND FITNESS FOR A PARTICULAR PURPOSE, AND DISCLAIMS ANY REMEDIES.

• MAINTENANCE

The specifications of maintenance parts may be partially changed within equivalent quality or better. In this product, AVIC will not accept to maintain for only mounting parts on circuit board (e.g. connector, fuse, capacitor, resistor, etc.) and only backlight conformation parts (e.g. reflector sheet, light guide plate, etc.).

If AVIC is planning discontinuation for this product, AVIC shall inform it to customers in six (6)-months advance from the issued date of official agreements. In addition, after product discontinuation, AVIC may replace substitutes instead of maintenance parts with whole product.

• CHANGE CONTROL

For the purpose of product improvement, this product design may be changed for specifications, appearance, parts, and circuits and so on. In case a design change is affected on the product specifications, AVIC shall inform it to customers in advance.

• HANDLING OF DOUBTFUL POINTS

Any question arising out of, or in connection with, this SPECIFICATION or any matter not stipulated herein will be settled each time upon consultation between both parties.



CONTENTS

INTRODUCTION.....	2
CONTENTS.....	3
Record of Revision.....	4
1. OUTLINE	5
1.1 STRUCTURE AND PRINCIPLE	5
1.2 APPLICATIONS	5
1.3 FEATURES	5
2. GENERAL SPECIFICATIONS	6
3. ABSOLUTE MAXIMUM RATINGS.....	7
4. BLOCK DIAGRAM	8
5. MECHANICAL SPECIFICATIONS	9
6. ELECTRICAL CHARACTERISTICS	9
7. CONNECTIONS AND FUNCTIONS FOR INTERFACE PINS	11
8. DISPLAY COLORS AND INPUT DATA SIGNALS	14
9. INTERFACE TIMING.....	15
10. OPTICS	19
11. MARKINGS.....	21
11.1 PRODUCT LABEL	21
11.2 OTHER MARKINGS	22
11.3 INDICATION LOCATIONS.....	22
12. PACKING, TRANSPORTATION AND DELIVERY	23
12.1 PACKING	23
12.2 INSPECTION RECORD SHEET	23
12.3 TRANSPORTATION	23
12.4 SIZE AND WEIGHT FOR PACKING BOX.....	23
12.5 OUTLINE FIGURE FOR PACKING	24
13. PRECAUTIONS	25
13.1 MEANING OF CUTION SIGNS	25
13.2 CAUTIONS.....	25
13.3 ATTENTIONS.....	25
14. OUTDRAWING.....	28



Record of Revision

Rev	Issued Date	Description	Editor
1.0	2009-12-22	Preliminary Release	Hyman Chen
2.0(1.1)	2010-06-01	Add "Operation life time, Differential input voltage"	Hyman Chen
3.0(1.2)	2010-7-7	LVDS interface (6 bit+HIFRC) revise	James Xiao
1.3	2011-03-04	Change the front cover to new format.	Wei Zhang



1. OUTLINE

1.1 STRUCTURE AND PRINCIPLE

TMS150XG1-10TB module is composed of the amorphous silicon thin film transistor liquid crystal display (a-Si TFT LCD) panel structure with driver LSIs for driving the TFT (Thin Film Transistor) array and a backlight. The a-Si TFT LCD panel structure is injected liquid crystal material into a narrow gap between the TFT array glass substrate and a color-filter glass substrate.

Color (Red, Green, Blue) data signals from a host system (e.g. PC, signal generator, etc.) are modulated into best form for active matrix system by a signal processing board, and sent to the driver LSIs which drive the individual TFT arrays. The TFT array as an electro-optical switch regulates the amount of transmitted light from the backlight assembly, when it is controlled by data signals. Color images are created by regulating the amount of transmitted light through the TFT array of red, green and blue dots.

1.2 APPLICATIONS

- Monitor for PC (for amusement or industry)

1.3 FEATURES

- a-Si TFT active matrix
- LVDS interface (6 bit+HIFRC)
- Wide viewing angle
- High response time: 8ms (typ.)
- PSWG standard
- High contrast: 600:1 (typ.)
- Edge light type backlight (Inverter less)
- ROHS compliance
- TCO'03 compliance



2. GENERAL SPECIFICATIONS

<i>Display area</i>	304.128 (W) x 228.096 (H) mm (typ.)
<i>Diagonal size of display</i>	38.0 cm (15.0 inches)
<i>Drive system</i>	a-Si TFT active matrix
<i>Display color</i>	16,777,216 colors (6bit+HIFRC)
<i>Pixel</i>	1,024 (H) x 768 (V) pixels
<i>Pixel arrangement</i>	RGB vertical stripe
<i>Dot pitch</i>	0.099 (W) x 0.297 (H) mm
<i>Pixel pitch</i>	0.297 (W) x 0.297 (H) mm
<i>Module size</i>	326.50 ± 0.5 (W) x 253.5 ± 0.5 (H) x 11.13 ± 0.5 (D) mm (typ.)
<i>Weight</i>	1000 g (typ.)
<i>Contrast ratio</i>	600:1 (typ.)
<i>Viewing angle</i>	160°/ 160° (typ.)
<i>Color gamut</i>	60 % (typ.)
<i>Response time</i>	8 ms (typ.)
<i>Luminance</i>	250cd/m ² (typ.)
<i>Transmissive Mode</i>	Normally White
<i>Surface Treatment</i>	AG Type
<i>Signal system</i>	LVDS 1port
<i>Power supply voltage</i>	LCD panel signal processing board: 3.3V
<i>Backlight</i>	2 cold cathode fluorescent lamps
<i>Power consumption</i>	(10.1)W (typ.)



3. ABSOLUTE MAXIMUM RATINGS

Parameter		Symbol	Rating	Unit	Remarks
Power supply voltage	LCD panel signal board	VDD	-0.3 ~ +3.6	V	Ta = 25°C
Input voltage for signals	Display signals Note1	Vi	-0.3 ~ +3.6 and Vi < VCC + 0.3	V	Ta = 25°C
	Function signals Note2				
Storage temperature		Tst	-20 ~ +60	°C	Note3
Operating temperature		Top	0 ~ +55	°C	Note3, 4
Absolute humidity		AH	≤ 70	g/m ³	Ta > 55°C
Operating altitude		-	≤ 4,850	m	0° C ≤ Ta ≤ 55° C
Storage altitude		-	≤ 13,600	m	-20° C ≤ Ta ≤ 60° C

Note1: Display signals are D0+/-, D1+/-, D2+/-, D3+/- and CK+/-.

Note2: Function signal is MSL.

Note3: Temperature and relative humidity range is shown in the figure below.

(a) 90%RH Max. (Ta ≤ 40°C)

(b) Web-bulb temperature should be 39°C Max. (Ta > 40°C)

(c) No condensation.

Note4: The temperature of panel display surface area should be 0°C Min and 60°C Max.

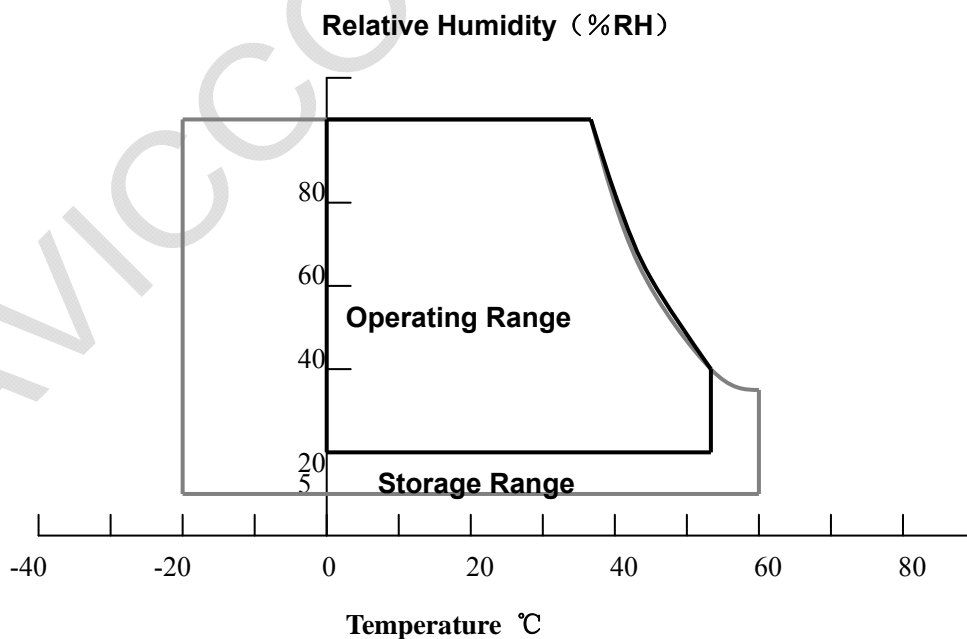



4. BLOCK DIAGRAM

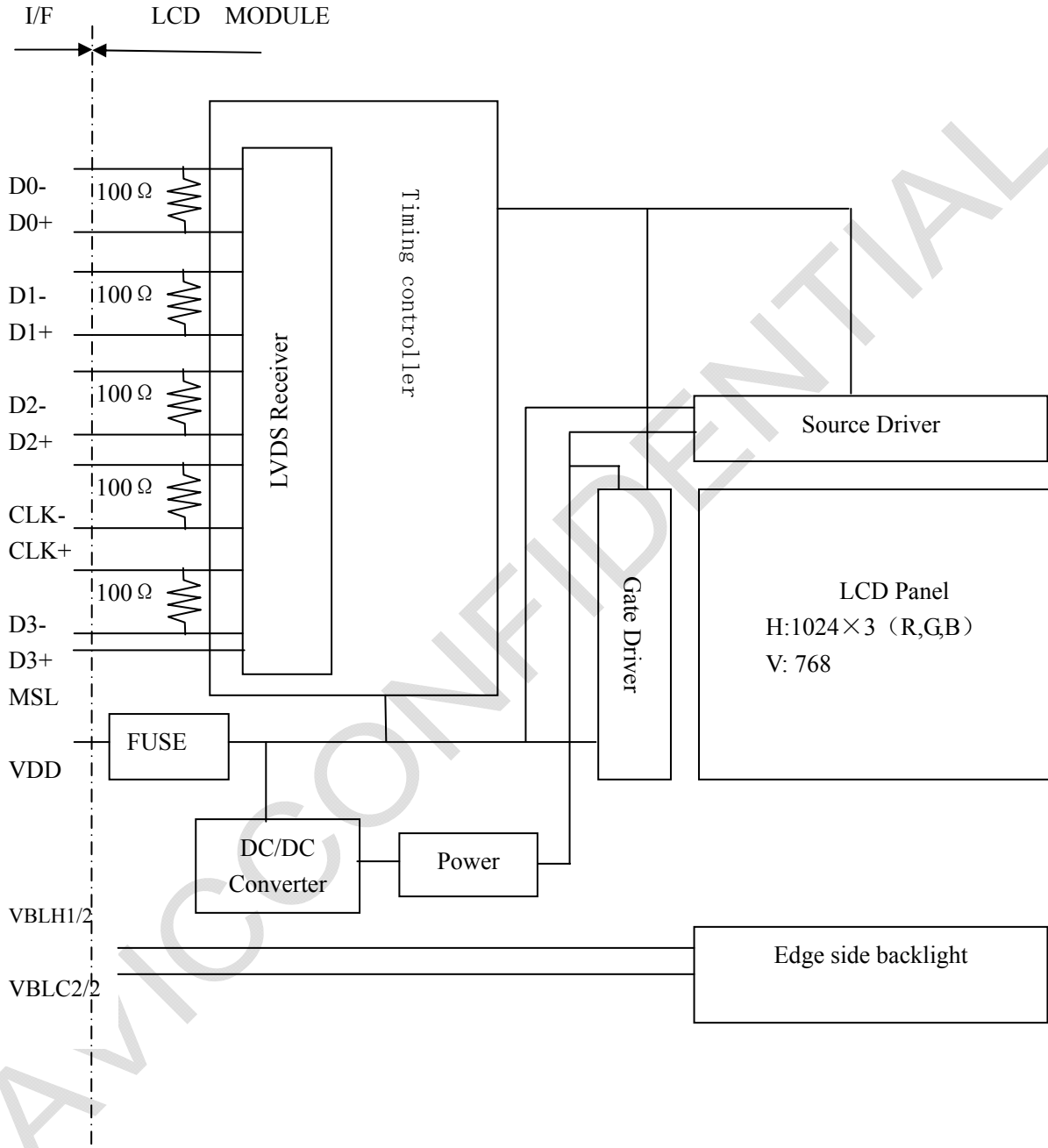

Note1: Connections between GND, FG (Frame ground) and VBLC (Lamp low voltage terminal) in the product

GND - FG	Connected
GND - VBLC	Not connected
FG - VBLC	Not connected

Note2: These grounds should be connected together in customer equipment.



5. MECHANICAL SPECIFICATIONS

Parameter	Specification	Unit
Module size	326.5±0.5 (W) x 253.5±0.5 (H) x 11.13±0.5 (D)	mm
Display area	304.128 (W) x 228.096 (H)	mm
Weight	1000 (typ.)	g

6. ELECTRICAL CHARACTERISTICS

6.1 Driving for LCD panel signal processing board

Parameter	Symbol	min.	typ.	max.	Unit	Remarks
Power supply voltage	VDD	3.0	3.3	3.6	V	-
Power supply current	IDD	-	500 ^{Note1}	700 ^{Note 2}	mA	at VDD = 3.3V
Permissible ripple voltage	VRP	-	-	100	mV	VDD
Differential input voltage	Vid	200	-	600	mV	-
Differential input threshold voltage for LVDS receiver	Low	VTL	-100	-	mV	at VCM = 1.2V Note3
	High	VTH	-	-	100	
Input voltage width for LVDS receiver	Vi	0	-	2.4	V	-
Terminating resistor	RT	-	100	-	Ω	-
Rush current	I _{rush}	-	-	2.0	A	Note4

Note 1: Checkered flag pattern (EIAJ ED-2522);

Note 2: 2H1V dot inverse pattern

Note 3: Common mode voltage for LVDS receiver

Note4: Measurement Conditions:

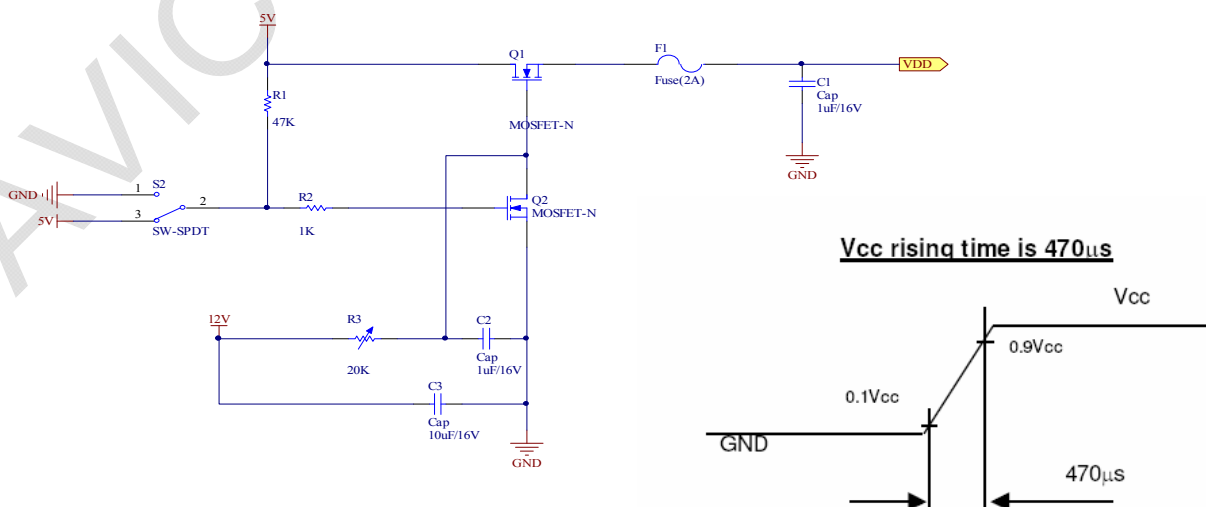

The information contained herein is the exclusive property of SHANGHAI AVIC OPTOELECTRONICS Corporation, and shall not be distributed, reproduced, or disclosed in whole or in part without prior written permission of SHANGHAI AVIC OPTOELECTRONICS Corporation.



6.2 Driving for backlight lamp

(Ta=25°C) Note1

Parameter	Symbol	min.	typ.	max.	Unit	Remarks
Lamp voltage	VBLH	549	610	671	Vrms	For each lamp
Lamp current	IBL	3.5	7.0	7.5	mArms	at L = 250cd/ m ² (typ.)
Lamp starting voltage Note1	VS	-	-	1600	Vrms	Ta = 0°C Note2
		-	-	1100	Vrms	Ta = 25°C Note2
Oscillation frequency	FO	40	50	60	kHz	Note3
Operation life time	Hr	40,000	-	-	Hour	Ta = 25°C IBL = 7.0 mArms Note4

Note1: The value is the characteristic of lamp. The starting voltage of inverter should be lower than the value. But the possibility of not lighting exists by the lower voltage, so the suitable voltage should be considered by the test.

Note2: The asymmetric ratio of working waveform for lamps (Lamp voltage peak ratio, Lamp current peak ratio and waveform space ratio) should be less than 5% (See the following figure). If the waveform is asymmetric, DC (Direct current) element applies into the lamp. In this case, a lamp lifetime may be shortened, because a distribution of a lamp enclosure substance inclines toward one side between low voltage terminal (Cold terminal) and high voltage terminal (Hot terminal).

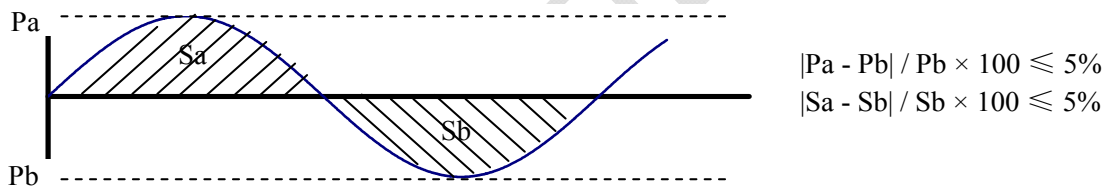

Pa: Supply voltage/current peak for positive, Pb: Supply voltage/current peak for negative

Sa: Waveform space for positive part, Sb: Waveform space for negative part

Note3: Recommended value of "FO" is as following.

$$FO = 1/4 \times 1/th \times (2n-1) \quad n: \text{Natural number } (1, 2, 3 \dots)$$

Note4: Lamp operating lifetime is mean time to half-luminance. In case the product works under low temperature environment, the lifetime becomes short.



7. CONNECTIONS AND FUNCTIONS FOR INTERFACE PINS

7.1 LCD panel signal processing board

CN1 socket(Module side): DF-14H-20P-1.25H (Hirose Electric Co., Ltd.)

Adaptable plug: DF14-20S-1.25C (Hirose Electric Co., Ltd.)

Pin No.	Symbol	Signal	Remarks
1	VCC	Power supply	-
2	VCC		
3	GND	Ground	-
4	GND		
5	D0-	Pixel data	Note2
6	D0+		
7	GND	Ground	-
8	D1-	Pixel data	Note2
9	D1+		
10	GND	Ground	-
11	D2-	Pixel data	Note2
12	D2+		
13	GND	Ground	-
14	CLK-	Pixel clock	Note2
15	CLK+		
16	GND	Ground	-
17	D3-	Pixel data	Note2
18	D3+		
19	GND	Ground	-
20	MSL	Selection of LVDS input Map	Low or Open: NOTE1

Note1: See“7.4 Connection between receiver and transmitter For LVDS”.

Note2: Twist pair wires with 100Ω (Characteristic impedance) should be connected between LCD panel signal processing board and LVDS transmitter.



7.2 Backlight lamp

CN201 CN202 plug (LCD module side): BHR-03VS-1 (J.S.T Mfg. Co., Ltd.)

Adaptable socket: SM02 (8.0) B-BHS-1-TB (J.S.T Mfg. Co., Ltd.)

Pin No.	Symbol	signal	remarks
1	VBLH	High voltage terminal(Hot)	Cable color: (Sky)Blue
2	VBLC	Low voltage terminal(Cold)	Cable color: White

7.3 Position of plugs and a socket

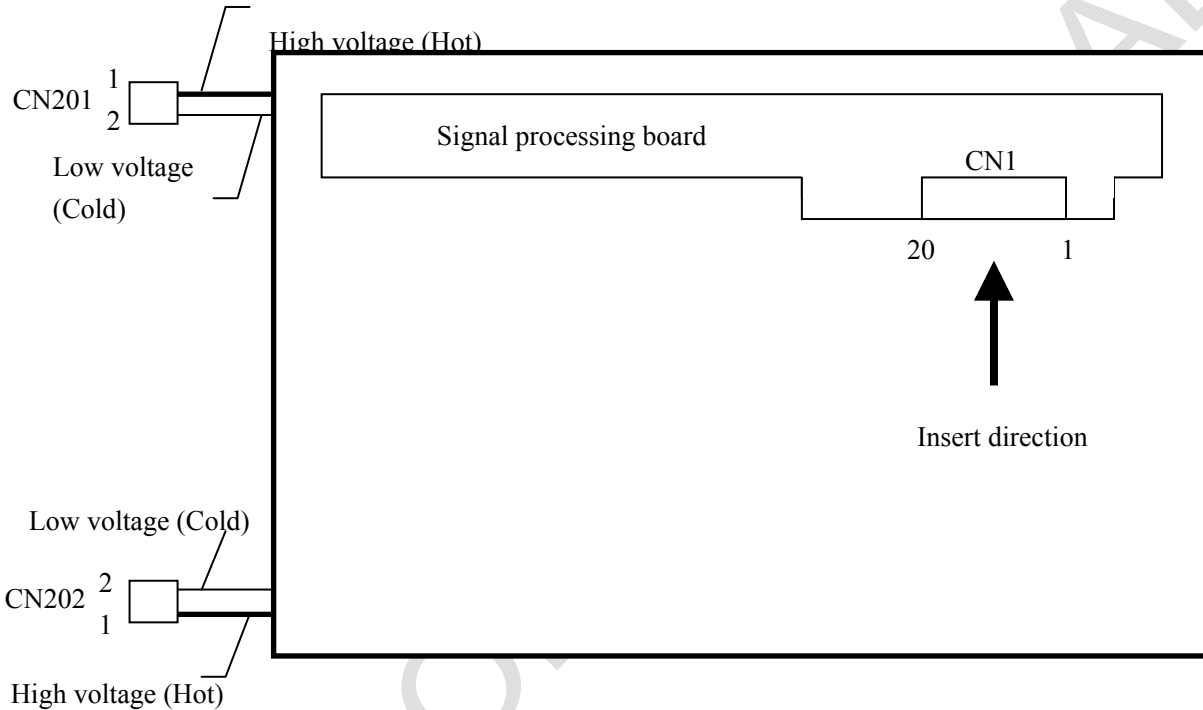



7.4 Connection between receiver and transmitter for LVDS

Input LVDS map (MSL: "Low" or "Open")

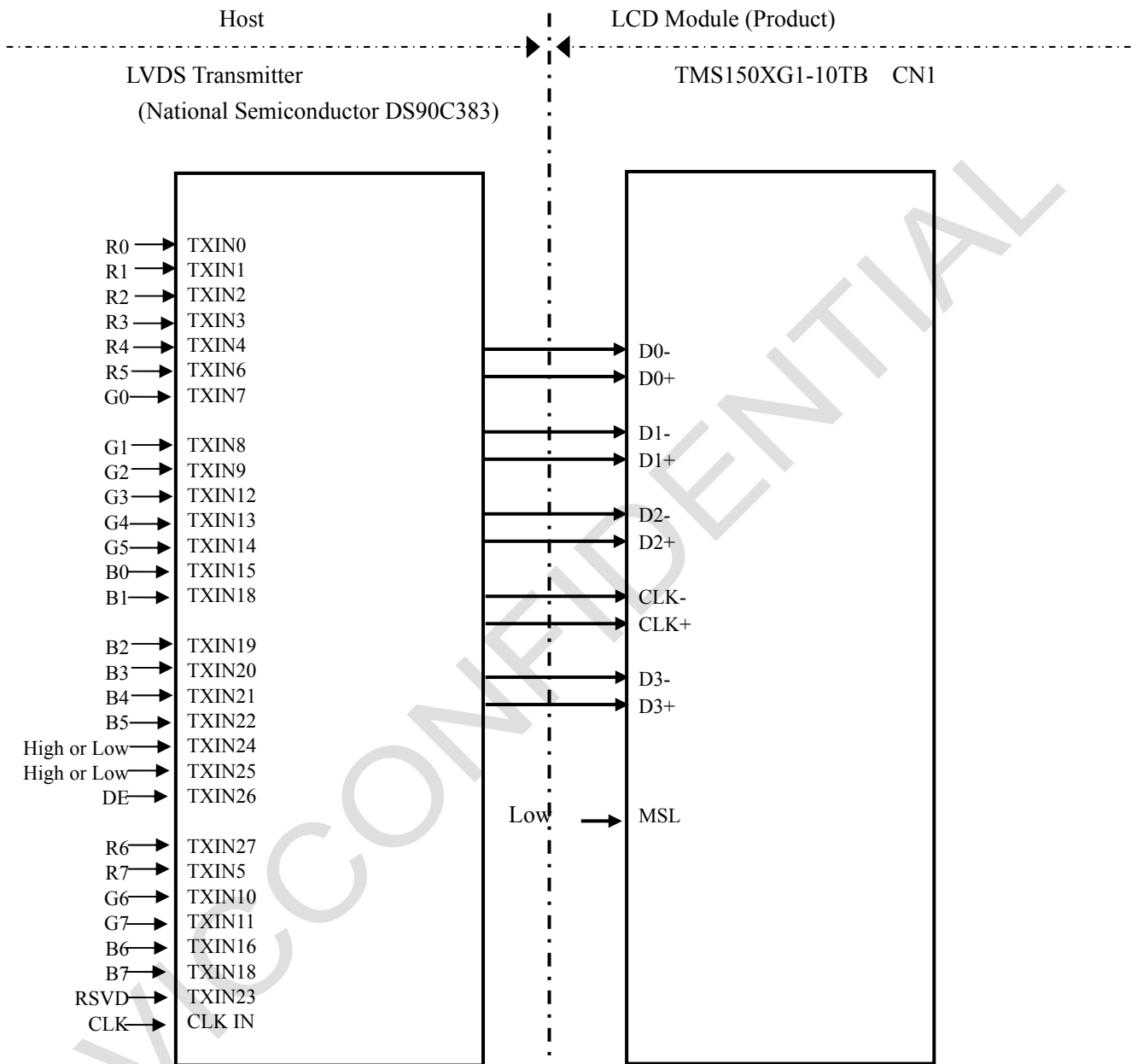

Note1: Recommended transmitter. See the data sheet for DS90C383 (National Semiconductor) .

Note2: LSB (Least Significant Bit) -R0,G0,B0 MSB (Most Significant Bit) -R7,G7,B7



8. DISPLAY COLORS AND INPUT DATA SIGNALS

This product can display in equivalent to 16,777,216 colors in 256 scales. Also the relation between display colors and input data signals is as the following table.

Display colors		Data signal (0:Low level, 1:High Level)																								
		R7	R6	R5	R4	R3	R2	R1	R0	G7	G6	G5	G4	G3	G2	G1	G0	B7	B6	B5	B4	B3	B2	B1	B0	
Basic Color	Black	0	0	0	0	0	0	0	0	0	0	0	0	0	0	0	0	0	0	0	0	0	0	0	0	
	Blue	0	0	0	0	0	0	0	0	0	0	0	0	0	0	0	0	1	1	1	1	1	1	1	1	
	Red	1	1	1	1	1	1	1	1	0	0	0	0	0	0	0	0	0	0	0	0	0	0	0	0	
	Magenta	1	1	1	1	1	1	1	1	0	0	0	0	0	0	0	0	1	1	1	1	1	1	1	1	
	Green	0	0	0	0	0	0	0	0	1	1	1	1	1	1	1	1	0	0	0	0	0	0	0	0	
	Cyan	0	0	0	0	0	0	0	0	1	1	1	1	1	1	1	1	1	1	1	1	1	1	1	1	
	Yellow	1	1	1	1	1	1	1	1	1	1	1	1	1	1	1	1	0	0	0	0	0	0	0	0	
	White	1	1	1	1	1	1	1	1	1	1	1	1	1	1	1	1	1	1	1	1	1	1	1	1	
Red grayscale	Black	0	0	0	0	0	0	0	0	0	0	0	0	0	0	0	0	0	0	0	0	0	0	0	0	
		0	0	0	0	0	0	0	1	0	0	0	0	0	0	0	0	0	0	0	0	0	0	0	0	
	Dark	0	0	0	0	0	0	1	0	0	0	0	0	0	0	0	0	0	0	0	0	0	0	0	0	
	↑																									
	↓																									
	Bright	1	1	1	1	1	1	0	1	0	0	0	0	0	0	0	0	0	0	0	0	0	0	0	0	
Red	1	1	1	1	1	1	1	0	0	0	0	0	0	0	0	0	0	0	0	0	0	0	0	0		
	1	1	1	1	1	1	1	1	0	0	0	0	0	0	0	0	0	0	0	0	0	0	0	0		
Green grayscale	Black	0	0	0	0	0	0	0	0	0	0	0	0	0	0	0	0	0	0	0	0	0	0	0	0	
		0	0	0	0	0	0	0	0	0	0	0	0	0	0	0	1	0	0	0	0	0	0	0	0	
	Dark	0	0	0	0	0	0	0	0	0	0	0	0	0	0	1	0	0	0	0	0	0	0	0	0	
	↑																									
	↓																									
	Bright	0	0	0	0	0	0	0	0	1	1	1	1	1	1	0	1	0	0	0	0	0	0	0	0	
Green	0	0	0	0	0	0	0	0	1	1	1	1	1	1	1	0	0	0	0	0	0	0	0	0		
	0	0	0	0	0	0	0	0	1	1	1	1	1	1	1	1	0	0	0	0	0	0	0	0		
Blue grayscale	Black	0	0	0	0	0	0	0	0	0	0	0	0	0	0	0	0	0	0	0	0	0	0	0	0	
		0	0	0	0	0	0	0	0	0	0	0	0	0	0	0	0	0	0	0	0	0	0	0	1	
	Dark	0	0	0	0	0	0	0	0	0	0	0	0	0	0	0	0	0	0	0	0	0	0	1	0	
	↑																									
	↓																									
	Bright	0	0	0	0	0	0	0	0	0	0	0	0	0	0	0	0	1	1	1	1	1	1	0	1	
Blue	0	0	0	0	0	0	0	0	0	0	0	0	0	0	0	0	1	1	1	1	1	1	1	0		
	0	0	0	0	0	0	0	0	0	0	0	0	0	0	0	0	1	1	1	1	1	1	1	1		

The information contained herein is the exclusive property of SHANGHAI AVIC OPTOELECTRONICS Corporation, and shall not be distributed, reproduced, or disclosed in whole or in part without prior written permission of SHANGHAI AVIC OPTOELECTRONICS Corporation.



9. INTERFACE TIMING

9.1 Timing characteristics

(Note1)

Parameter		Symbol	min.	typ.	max.	Unit	Remarks	
CLK	Frequency	1/tc	54	65.0	81	MHz	15.384ns (typ.)	
	Duty	—	—			—	Note2	
	Rise time, Fall time	—	—			ns		
DATA	CLK-DATA	Setup time	—			ns	Note2	
		Hold time	—			ns		
	Rise time, Fall time	—	—			ns		
DE	Horizontal	Cycle	th	12.3	20.676	30.00	μs	48.363KHz(typ.)
				1050	1344	1800	CLK	Note3 Note4
	Display period	thd	1024				—	
	Vertical (One frame)	Cycle	tv	13.1	16.666	20.0	ms	60.0Hz (typ.)
				770	806	1334	H	
	Display period	tvd	768			H		
	CLK-DE	Setup time	—	—			ns	Note2
Hold time		—	—			ns		
Rise time, Fall time		—	—			ns		

Note1: Definition of parameters is follows. $t_c=1\text{CLK}$, $T_h=1H$

Note 2: See the data sheet of LVDS transmitter.

Note 3: Both of “time” and “CLK number” of the “th” must keep the Minimum value of specifications.

Note 4: “th” must keep the fluctuation within $\pm 1\text{ CLK}$, because of avoidance of image sticking.



9.2 Input signal timing chart

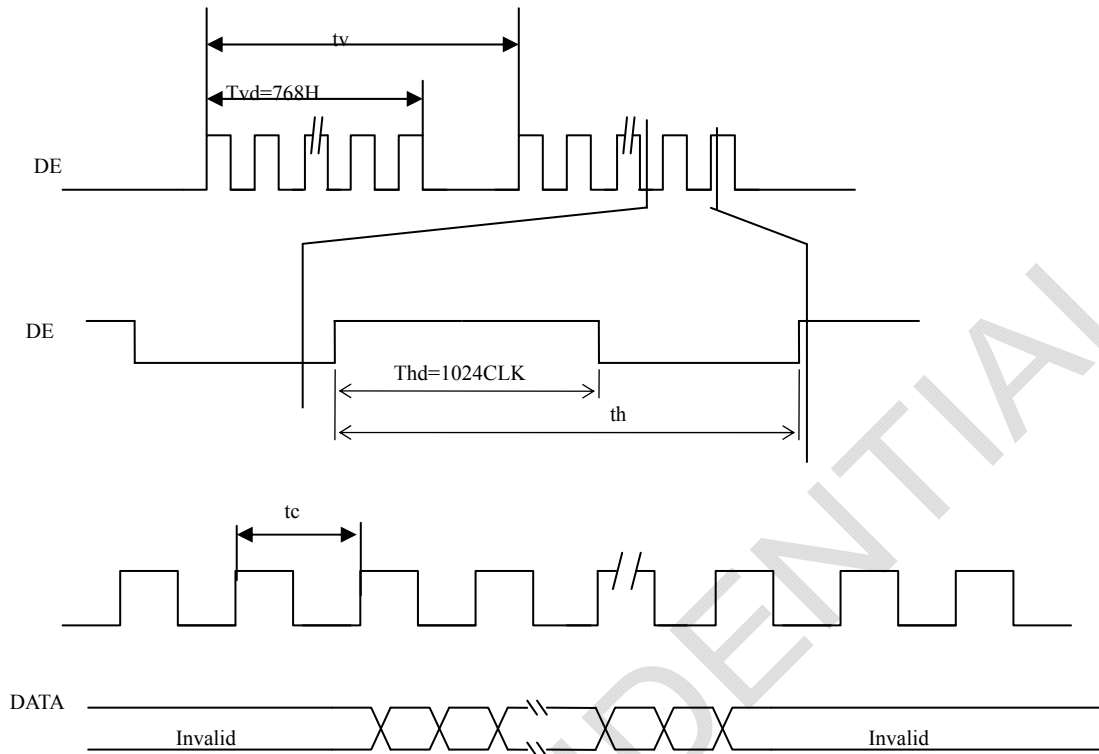

9.3 Pixel DATA alignment of display image

The following table is the coordinates per pixel

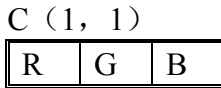

C (1, 1)	C (2, 1)	...	C (X, 1)	...	C (1023, 1)	C (1024, 1)
C (1, 2)	C (2, 2)	...	C (X, Y)	...	C (1023, 2)	C (1024, 2)
.
.
.
C (1, Y)	C (2, Y)	...	C (X, Y)	...	C (1023, Y)	C (1024, Y)
.
.
.
C (1, 767)	C (2, 767)	...	C (X, 767)	...	C (1023, 767)	C (1024, 767)
C (1, 768)	C (2, 768)	...	C (X, 768)	...	C (1023, 767)	C (1024, 768)



9.4. POWER SUPPLY VOLTAGE SEQUENCE

9.4.1 The sequence of backlight and power

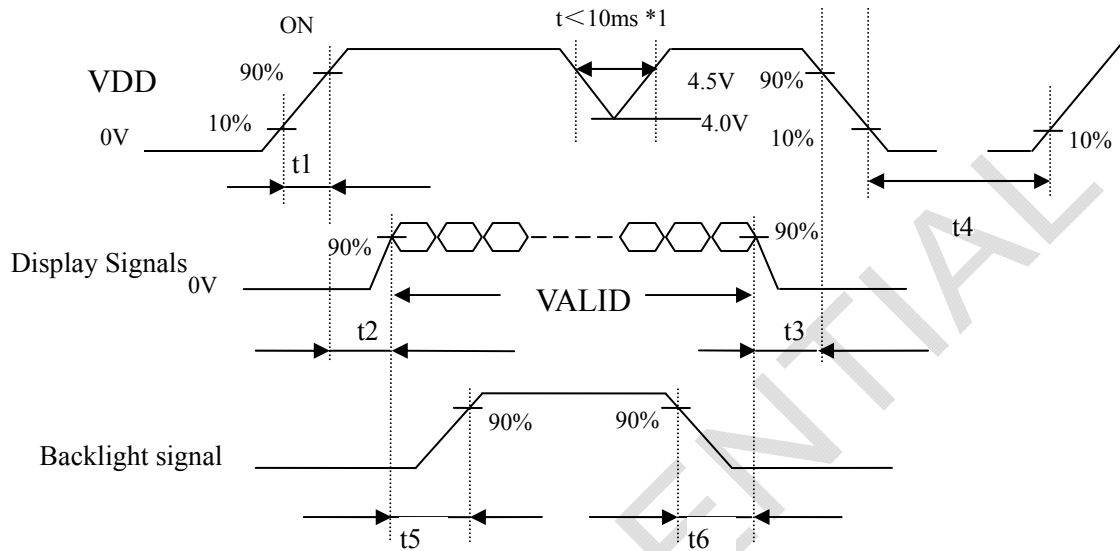

Timing Specifications:

$$0.47\text{ms} < t1 < 10\text{ms}; \quad 0.5\text{ms} < t2 < 50\text{ms}; \quad 0\text{ms} < t3 < 50\text{ms};$$

$$t4 > 1000\text{ms}; \quad t5 > 200\text{ms}; \quad t6 > 200\text{ms};$$

*1: These signals should be measured at the terminal of 100Ω resistor.

[NOTE ITEM]

Note1: In terms of voltage variation (voltage drop) while VCC rising edge is below 3.0 V, a protection circuit may work, and then this product may not work.

Note2: Display signals (D0+/-, D1+/-, D2+/-, D3+/- and CK+/-) and function signal (MSL) must be "0" voltage, exclude the VALID period (See above sequence diagram). If these signals are higher than 0.3 V, the internal circuit is damaged.

If some of display and function signals of this product are cut while this product is working, even if the signal input to it once again, it might not work normally. If customer stops the display and function signals, they should be cut VCC.

Note3: The backlight power supply voltage should be inputted within the valid period of display and function signals, in order to avoid unstable data display.

Note4: In order to prevent unstable data displaying, suggest that, during display and function signal's valid period, backlight power voltage should be input under the custom ' condition as possible.



9.4.2 Power supply voltage ripple

This product works, even if the ripple voltage levels are beyond the permissible values as the following table, but there might be noise on the display image.

Parameter	Power supply voltage	Ripple voltage Note1 (Measured at input terminal of power supply)	Unit
VCC	3.3 V	≤ 100	mVp-p

Note1: The permissible ripple voltage includes spike noise.

9.4.3 Fuse

Parameter	Fuse		Rating	Fusing current	Remarks
	Type	Supplier			
VCC	TF16SN2.50	KOA Corporation	1.5 A	5.0 A	Note1
			32 V		

Note1: The power supply capacity should be more than the fusing current. If the power supply capacity is less than the fusing current, the fuse may not blow for a short time, and then nasty smell, smoking and so on may occur.

**10. OPTICS**

10.1 Optical characteristics

Parameter Note1		Condition	Symbol	min.	typ.	max.	Unit
Luminance		White at center R=0, L=0, U=0,D=0	L	200	250	-	cd/ m ²
Contrast ratio		White/Black at center R=0, L=0, U=0,D=0	CR	400	600	-	-
Luminance uniformity		-	LU	-	1.2	1.3	-
Chromaticity	White	X coordinate	Wx	0.283	0.313	0.343	-
		Y coordinate	Wy	0.299	0.329	0.359	-
	Red	X coordinate	Rx	0.60	0.63	0.66	-
		Y coordinate	Ry	0.31	0.34	0.37	-
	Green	X coordinate	Gx	0.27	0.30	0.33	-
		Y coordinate	Gy	0.54	0.57	0.60	-
	Blue	X coordinate	Bx	0.11	0.14	0.17	-
		Y coordinate	By	0.07	0.10	0.13	-
Color gamut		R=0, L=0, U=0,D=0	C	50	60	-	%
Response time		White to black	Ton	-	2	4	ms
		Black to white	Toff	-	6	8	ms
Viewing angle	Right	$\theta U=0^\circ, \theta D=0^\circ, CR=10$	θR	70	80	-	°
	Left	$\theta U=0^\circ, \theta D=0^\circ, CR=10$	θL	70	80	-	°
	Up	$\theta R=0^\circ, \theta L=0^\circ, CR=10$	θU	70	80	-	°
	Down	$\theta R=0^\circ, \theta L=0^\circ, CR=10$	θD	70	80	-	°

Note1: Measurement conditions are follows.

Ta=25C, VCC=3.3V, IBL=7mArms/lamp, Display mode: XGA, Horizontal cycle=48.363 KHz, Vertical cycle=60.000Hz

Optical characteristics are measured at luminance saturation after 20minutes from working the product, in the dark room. Also measurement method for luminance is as follows.

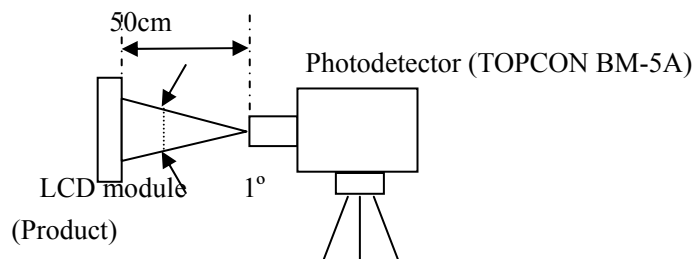

Note 2: See“10.2 Definition of contrast ratio”.

Note 3: See“10.3 Definition of luminance uniformity”.

Note 4: Temperature: Top=25.0°C

Note 5: See “10.4 Definition of response times”.

Note 6: See “10.5 Definition of viewing angles”.



10.2 Definition of contrast ratio

The contrast ratio is calculated by using the following formula.

$$\text{Contrast ratio (CR)} = \frac{\text{Luminance of white screen}}{\text{Luminance of black screen}}$$

10.3 Definition of luminance uniformity

The luminance uniformity is calculated by using the following formula.

$$\text{Luminance uniformity (LU)} = \frac{\text{Maximum luminance from } \textcircled{1} \text{ to } \textcircled{9}}{\text{Minimum luminance from } \textcircled{1} \text{ to } \textcircled{9}}$$

The luminance is measured at near the 9 points shown below.

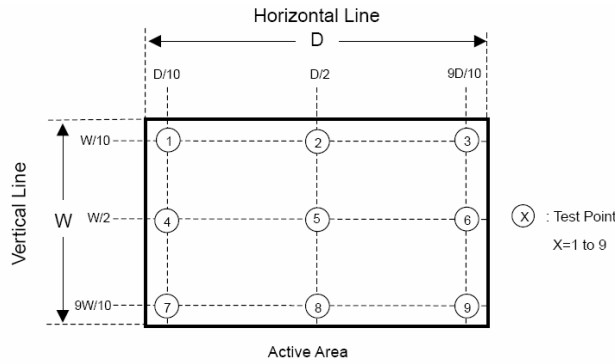

10.4 Definition of response times

Response time is measured, the luminance changes from “white” to “black”, or “black” to “white” on the same screen point, by photo-detector. Ton is the time it takes the luminance change from 90% down to 10%. Also Toff is the time it takes the luminance change from 10% up to 90%. (See the following diagram.)

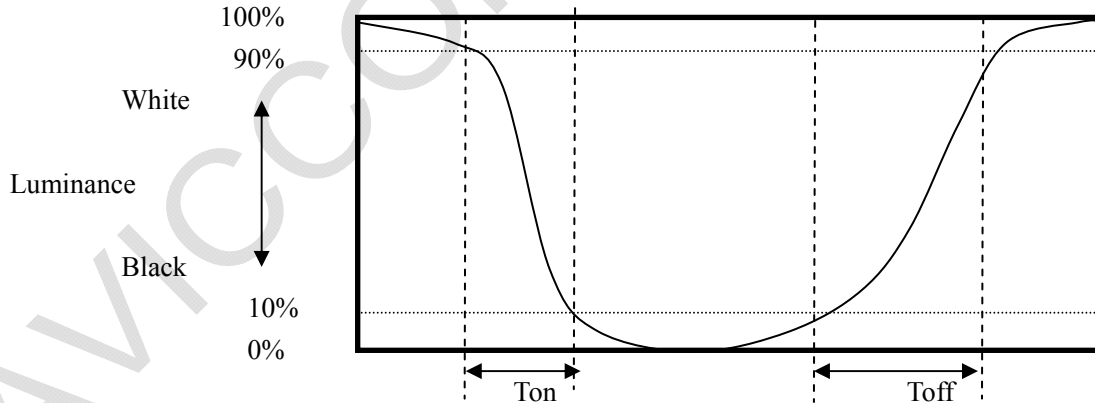



10.5 Definition of viewing angles

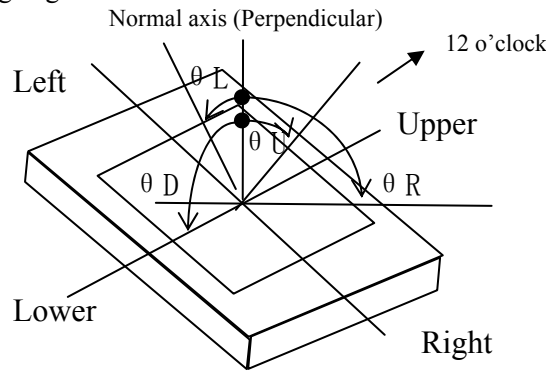

11. MARKINGS

The various markings are attached to this product. See “11.3 INDECATION LOCATIONS” for attachment positions.

11.1 PRODUCT LABEL



Note1: The meaning of OEM number

•Example: TM5XG10A55SA1SA19CF0001



Date code:

1st Character Year Codes

Month	2006	2007	2008	2009	2010	2011	2012	2013	2014	2015	2016	So on
Code	6	7	8	9	0	1	2	3	4	5	6	

2nd Character Month Codes

Month	January	February	March	April	May	June	July	August	September	October	November	December
Code	1	2	3	4	5	6	7	8	9	A	B	C

The information contained herein is the exclusive property of SHANGHAI AVIC OPTOELECTRONICS Corporation, and shall not be distributed, reproduced, or disclosed in whole or in part without prior written permission of SHANGHAI AVIC OPTOELECTRONICS Corporation.



3rd Character Day Codes

Day	1st	2nd	3rd	4th	5th	6th	7th	8th	9th	10th	11st	12nd
Code	1	2	3	4	5	6	7	8	9	A	B	C

13rd	14th	15th	16th	17th	18th	19th	20th	21st	22nd	23rd	24th
D	E	F	G	H	J	K	L	M	N	P	Q

25th	26th	27th	28th	29th	30th	31st
R	S	T	U	V	W	X

Note2: **Do not attach anything such as label and so on, on the product label!** In case repair the product, AVIC needs the contents of product label such as the lot number, inspection date and so on, to identify the warranty period with individual product. If AVIC cannot decipher the contents of product label, such repair shall be entitled to charge. Also AVIC may give a new lot number to reconditioned products.

11.2 OTHER MARKINGS

High voltage caution marking



Disposal method marking for lamp

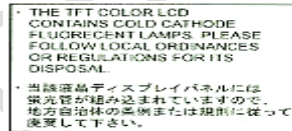

11.3 INDICATION LOCATIONS

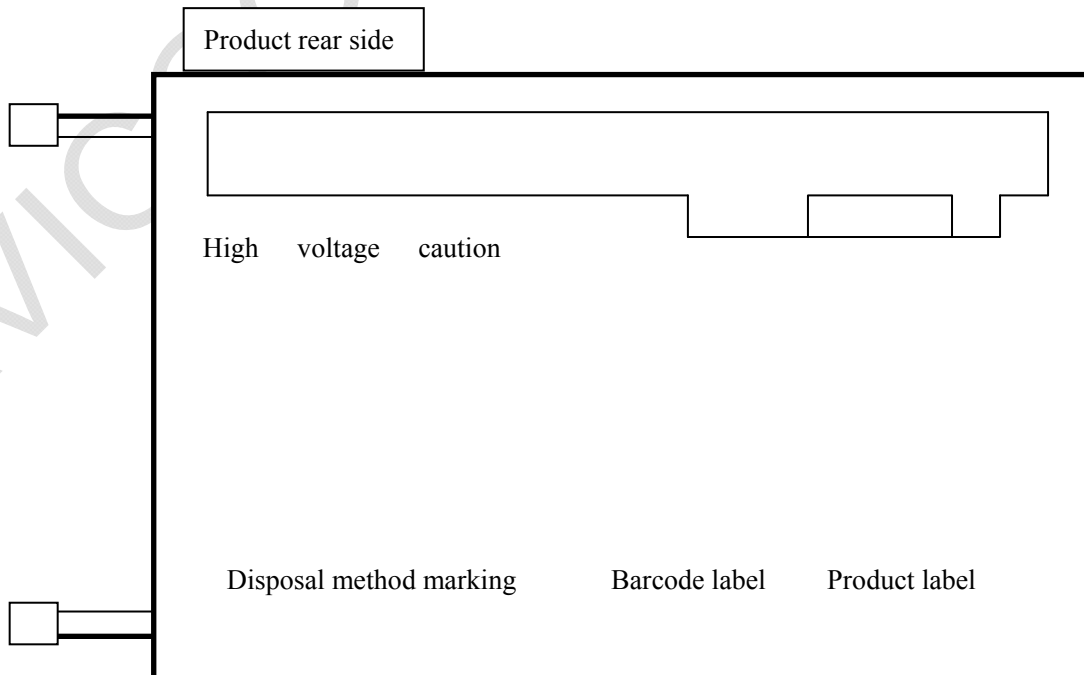



12. PACKING, TRANSPORTATION AND DELIVERY

AVIC will pack products to deliver to customer in accordance with AVIC packing specifications, and will deliver products to customer in such a state that products will not suffer from damage during transportation. The delivery conditions are as follows.

12.1 PACKING

(1) Packing box

14 products are packed up with the maximum in a packing box (See “12.5 OUTLINE FIGURE FOR PACKING”). Products are put into a plastic bag for prevention of moisture with cushion, and then the bag is sealed up with heat sealing.

The type name and quality are shown on outside of the packing box, either labeling or printing.

(2) Pallet Packing (See “12.5 OUTLINE FIGURE FOR PACKING”)

- ① Packing boxes are tied on a cardboard pallet. (9 boxes×3 tiers maximum)
- ② Cardboard sleeve and top cap are attached to the packing boxes, and then they are fixed by a band.

12.2 INSPECTION RECORD SHEET

Inspection record sheets are included in the packing box with delivery products to customer. It is summarized to a number of products for pass/fail assessment.

12.3 TRANSPORTATION

The product is transported by vehicle, aircraft or shipment in the state of pallet packing.

12.4 SIZE AND WEIGHT FOR PACKING BOX

Parameter	Packing box	Unit
Size	378 (L) x368 (W) x315.5 (H) (typ.)	mm
Weight	1 (typ.)	kg
Total weight	14.6 (typ.) (with 14 products)	kg



12.5 OUTLINE FIGURE FOR PACKING

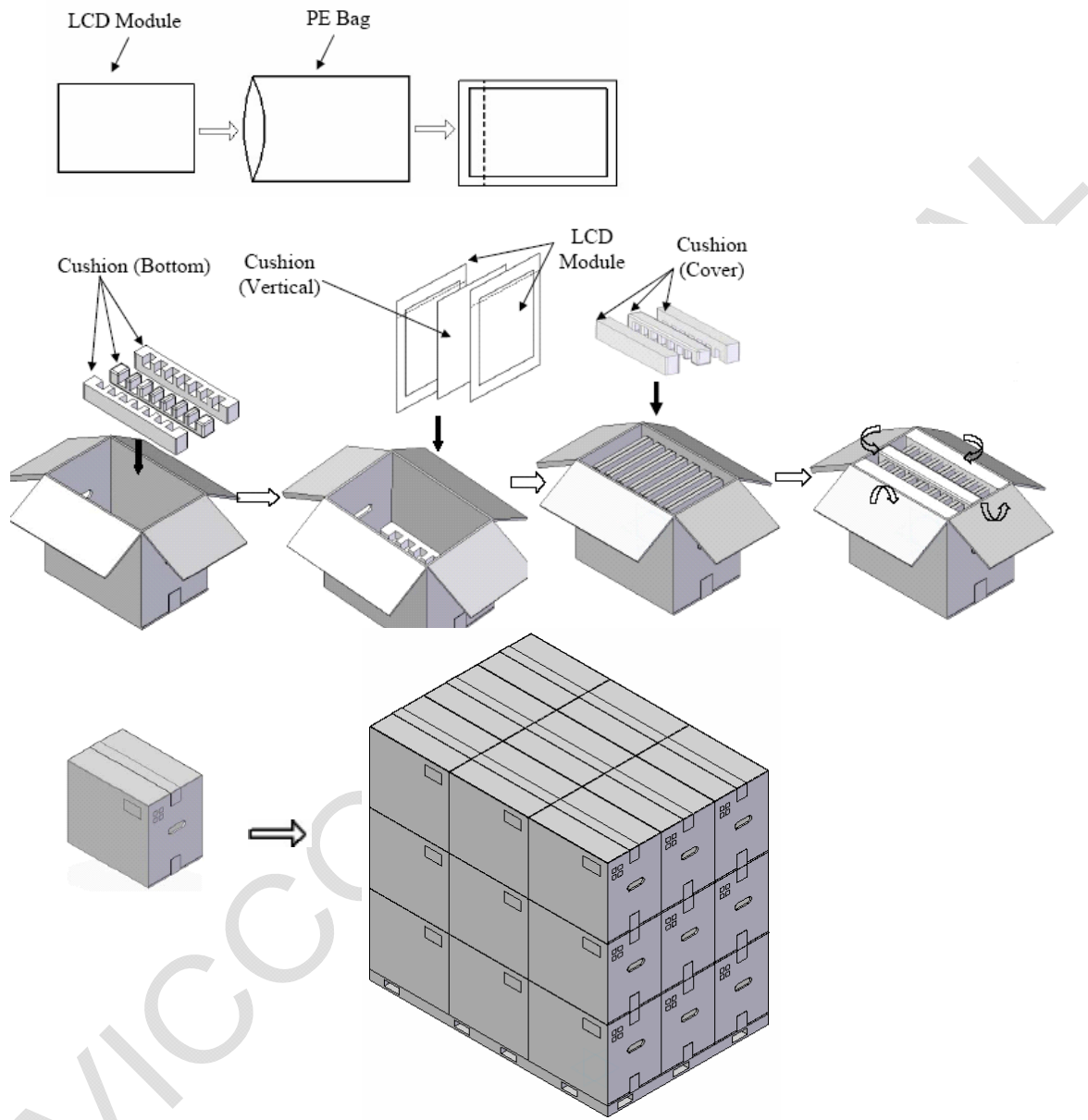



13. PRECAUTIONS

13.1 MEANING OF CAUTION SIGNS

The following caution signs have very important meaning .**Be sure to read “13.2 CAUTIONS” and “13.3 ATTENTIONS”, after understanding these contents!**



This sign have the meaning that customer will be injured by himself or the product will sustain a damage, if customer has wrong operations.



This sign has the meaning that customer will get an electrical shock, if customer has wrong operations.



This sign has the meaning that customer will be injured by himself, if customer has wrong operations.

13.2 CAUTIONS



*** Do not touch lamp cables while turn on .Customers will be in danger of an electric shock**



*** Do not touch the working backlight and IC. Customers will be in danger of burn injury.**

*** Do not shock and press the LCD panel and the backlight! There is a danger of breaking, because they are made of glass.(shock :To be not greater 294m/s^2 and to be not greater 11ms, Pressure: To be not greater 19.6N)**

13.3 ATTENTIONS



13.1 Handling of the product

- ① Take hold of both ends without touch the circuit board when customer pulls out products (LCD modules) from inner packing box. If customer touches it, products may be broken down or out of adjustment, because of stress to mounting parts.
- ② Do not hook cables nor pull connection cables such as flexible cable and so on, for fear of damage.
- ③ If customer puts down the product temporarily, the product puts on flat subsoil as a display side turns down.
- ④ Take the measures of electrostatic discharge such as earth band, ionic shower and so on, when customer deal with the product, because products may be damaged by electrostatic.
- ⑤ The torque for mounting screws must never exceed 0.34N-m. Higher torque values might result in distortion of the bezel.

The information contained herein is the exclusive property of SHANGHAI AVIC OPTOELECTRONICS Corporation, and shall not be distributed, reproduced, or disclosed in whole or in part without prior written permission of SHANGHAI AVIC OPTOELECTRONICS Corporation.



- ⑥ The product must be installed using mounting holes without undue stress such as bends or twist (See outline drawings). And do not add undue stress to any portion (such as bezel flat area) except mounting hole portion. Bends or twist described above and undue stress to any portion except mounting whole portion may cause display un-uniformity.
- ⑦ Do not press or rub on the sensitive display surface. If customer clean on the panel surface, AVIC recommends using the cloth with ethanol liquid such as screen cleaner for LCD.
- ⑧ Do not push-pull the interface connectors while the product is working, because wrong power sequence may break down the product.
- ⑨ Do not bend or unbend the lamp cable at the near part of the lamp holding rubber, to avoid the damage for high voltage side of the lamp. This damage may cause a lamp breaking and abnormal operation of high voltage circuit.

13.2 Environment

- ① Do not operate or store in high temperature, high humidity, dewdrop atmosphere or corrosive gases. Keep the product in antistatic pouch in room temperature, because of avoidance for dusts and sunlight, if customer stores the product.
- ② In order to prevent dew condensation occurring by temperature difference, the product packing box must be opened after leave under the environment of an unpacking room temperature enough. Because a situation of dew condensation occurring is changed by the environment temperature and humidity, evaluate the leaving time sufficiently. (Recommendation leaving time: 6 hour or more with packing state)
- ③ Do not operate in a high magnetic field. Circuit boards may be broken down by it.
- ④ This product is not designed as radiation hardened.
- ⑤ Use an original protection sheet on the product surface (polarizer). Adhesive type protection sheet should be avoided, because it may change color or properties of the polarizer.

13.3 Characteristics

The following items are neither defects nor failures.

- ① Response time, luminance and color may be changed by ambient temperature.
- ② The LCD may be seemed luminance non-uniformity, flicker, vertical seam or small spot by display patterns.
- ③ Optical characteristics (e.g. luminance, display uniformity, etc.) gradually is going to change depending on operating time, and especially low temperature, because the LCD has cold cathode fluorescent lamps.
- ④ Do not display the fixed pattern for a long time because it may cause image sticking. Use a screen saver, if the fixed pattern is displayed on the screen.
- ⑤ The display color may be changed by viewing angle because of the use of condenser sheet in the backlight.
- ⑥ Optical characteristics may be changed by input signal timings.
- ⑦ The interference noise of input signal frequency for this product and luminance control frequency of customer's backlight inverter may appear on a display. Set up luminance control frequency of backlight inverter so that the interference noise does not appear.

13.4 Other

- ① All GND and VCC terminals should be used without a non-connected line.
- ② Do not disassemble a product or adjust volume without permission of AVIC.
- ③ Pay attention not to insert waste materials inside of products, if customer uses screw nails.



- ④Pack the product with original shipping package, because of avoidance of some damages during transportation, when customer returns it to AVIC for repair and so on .
- ⑤Not only the module but also the equipment should be packed and transported as the module. Becomes vertical .Otherwise, there is the fear that a display dignity decreases by an impact or vibrations.

AVICCONFIDENTIAL



14. OUTDRAWING

