

## TFT LCD Approval Specification

# MODEL NO.: G104X1 - L03

Customer: \_\_\_\_\_

Approved by: \_\_\_\_\_

Note:

核准時間	部門	審核	角色	投票
2009-10-22 13:43:02	APPL 產品管理二部	張喻翔 (yhchang)	Director	Accept

## - CONTENTS -

REVISION HISTORY	-----	3
1. GENERAL DESCRIPTION	-----	4
1.1 OVERVIEW		
1.2 FEATURES		
1.3 APPLICATION		
1.4 GENERAL SPECIFICATIONS		
1.5 MECHANICAL SPECIFICATIONS		
2. ABSOLUTE MAXIMUM RATINGS	-----	5
2.1 ABSOLUTE RATINGS OF ENVIRONMENT		
2.2 ELECTRICAL ABSOLUTE RATINGS		
2.2.1 TFT LCD MODULE		
3. ELECTRICAL CHARACTERISTICS	-----	6
3.1 TFT LCD MODULE		
3.2 BACKLIGHT UNIT		
4. BLOCK DIAGRAM	-----	8
4.1 TFT LCD MODULE		
4.2 BACKLIGHT UNIT		
5. INTERFACE PIN ASSIGNMENT	-----	9
5.1 TFT LCD MODULE		
5.2 BLOCK DIAGRAM OF INTERFACE		
5.3 BACKLIGHT UNIT		
5.4 LVDS INTERFACE		
5.5 COLOR DATA INPUT ASSIGNMENT		
6. INTERFACE TIMING	-----	15
6.1 INPUT SIGNAL TIMING SPECIFICATIONS		
6.2 POWER ON/OFF SEQUENCE		
7. OPTICAL CHARACTERISTICS	-----	18
7.1 TEST CONDITIONS		
7.2 OPTICAL SPECIFICATIONS		
8. DEFINITION OF LABELS	-----	22
8.1 CMO MODULE LABEL		
9. PACKAGING	-----	23
9.1 PACKING SPECIFICATIONS		
9.2 PACKING METHOD		
10. PRECAUTIONS	-----	25
10.1 ASSEMBLY AND HANDLING PRECAUTIONS		
10.2 SAFETY PRECAUTIONS		
11. MECHANICAL CHARACTERISTIC	-----	25

**REVISION HISTORY**

Version	Date	Page (New)	Section	Description
2.0	2009/Oct/15	All	All	Approval spec was first issued

## 1. GENERAL DESCRIPTION

### 1.1 OVERVIEW

G104X1- L03 is a 10.4" TFT Liquid Crystal Display module with LED backlight unit and 30-pin-and-1ch LVDS interface. This product supports 1024 x 768 XGA format and can display true 16.2M colors (6-bits colors with FRC). The converter module for LED backlight is built-in.

### 1.2 FEATURES

- Excellent brightness (350 nits)
- Ultra high contrast ratio (1200:1)
- Fast response time (Ton+Toff average 25 ms)
- High color saturation NTSC 57%
- XGA (1024 x 768 pixels) resolution
- DE (Data Enable) only mode
- LVDS (Low Voltage Differential Signaling) interface
- Ultra wide viewing angle: 176(H)/ 176(V) (CR>10) Super MVA technology
- 180 degree rotation display option
- Color reproduction (Nature color)
- Wide operation and storage temperature range (-20 to 70 operation, -20 to 80 storage)

### 1.3 APPLICATION

- TFT LCD monitor for Industrial applications
- Slim design display for portable applications
- Digitizer Applicable Design

### 1.4 GENERAL SPECIFICATIONS

Item	Specification	Unit	Note
Active Area	210.4 (H) x 157.8 (V) (10.4" diagonal)	mm	(1)
Bezel Opening Area	215.4 (H) x 161.8 (V)	mm	
Driver Element	a-si TFT active matrix	-	-
Pixel Number	1024 x R.G.B. x 768	pixel	-
Pixel Pitch (Sub Pixel)	0.0685 (H) x 0.2055 (V)	mm	-
Pixel Arrangement	RGB vertical stripe	-	-
Display Colors	16.2 M	color	-
Display Operation Mode	Transmissive mode / Normally black	-	-
Surface Treatment	Anti Glare	-	-
Total power consumption(typ)	5.1	W	typ

Note (1) Please refer to the attached drawings for more information of front and back outline dimensions.

## 1.5 MECHANICAL SPECIFICATIONS

Item		Min.	Typ.	Max.	Unit	Note
Module Size	Horizontal (H)	-	238.6	-	mm	(1)
	Vertical (V)	-	175.8	-	mm	
	Depth (D)	-	7.5	-	mm	
Weight		-	280	-	g	-

Note (1) Please refer to the attached drawings for more information of front and back outline dimensions.

## 2. ABSOLUTE MAXIMUM RATINGS

### 2.1 ABSOLUTE RATINGS OF ENVIRONMENT

Item	Symbol	Value		Unit	Note
		Min.	Max.		
Operating Ambient Temperature	$T_{OP}$	-20	+70	°C	
Storage Temperature	$T_{ST}$	-20	+80	°C	

Note (1) Temperature and relative humidity range is shown in the figure below.

- (a) 90 %RH Max. ( $T_a \leq 40$  °C).
- (b) Wet-bulb temperature should be 39 °C Max. ( $T_a > 40$  °C).
- (c) No condensation

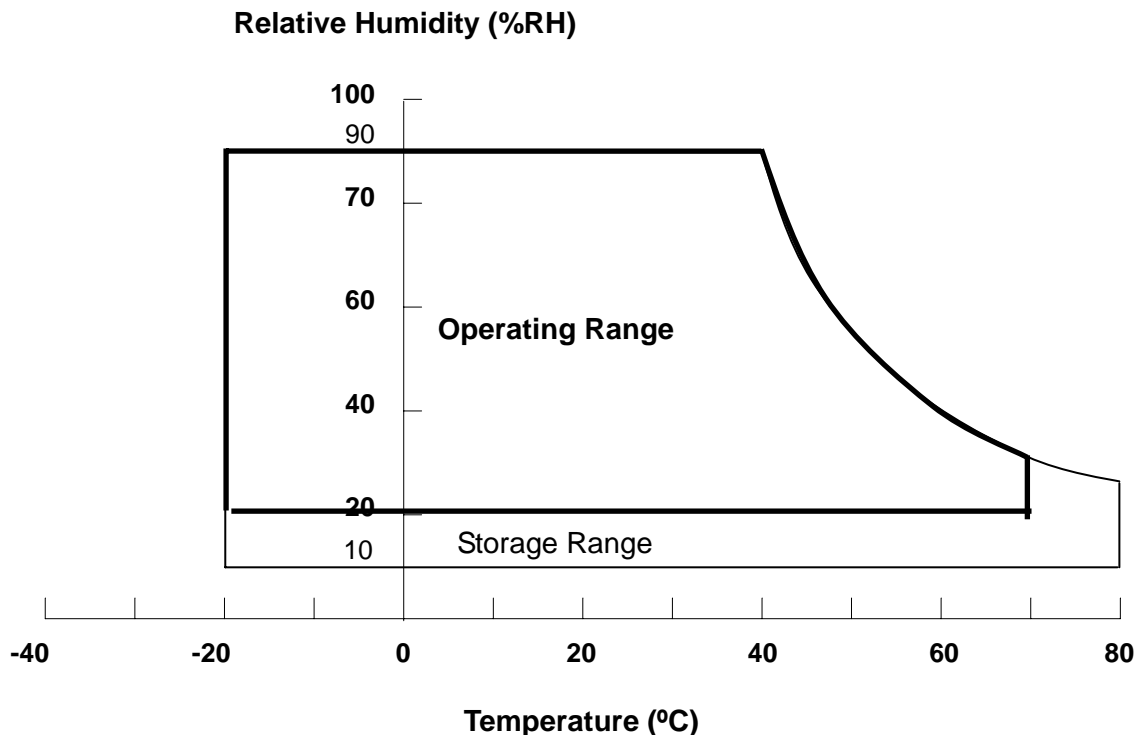

## 2.2 ELECTRICAL ABSOLUTE RATINGS

### 2.2.1 TFT LCD MODULE

Item	Symbol	Value		Unit	Note
		Min.	Max.		
Power Supply Voltage	VCC	-0.3	7	V	(1)

### 2.2.2 LED CONVERTER

Item	Symbol	Value		Unit	Note
		Min.	Max.		
Converter Voltage	$V_i$	-0.3	22	V	(1), (2)
Enable Voltage	EN	---	5.5	V	
Backlight Adjust	ADJ	---	5.5	V	

Note (1) Permanent damage to the device may occur if maximum values are exceeded. Function operation should be restricted to the conditions described under Normal Operating Conditions.

Note (2) Specified values are for lamp (Refer to 3.2 for further information).

## 3. ELECTRICAL CHARACTERISTICS

### 3.1 TFT LCD MODULE

$T_a = 25 \pm 2 \text{ }^\circ\text{C}$

Parameter	Symbol	Value			Unit	Note
		Min.	Typ.	Max.		
Power Supply Voltage	$V_{CC}$	3.0	3.3	3.6	V	(1)
Rush Current	$I_{RUSH}$	-	-	4.0	A	(2)
Power Supply Current	White	-	600	-	mA	(3)
	Black	-	430	-	mA	
Power Consumption	$P_L$	---	2.0	---	W	
LVDS differential input voltage	$ VID $	100	-	600	mV	-
LVDS common input voltage	$V_{ICM}$	0.7	-	1.6	V	-

Note (1) The assembly should be always operated within above ranges.

Note (2) Measurement Conditions:

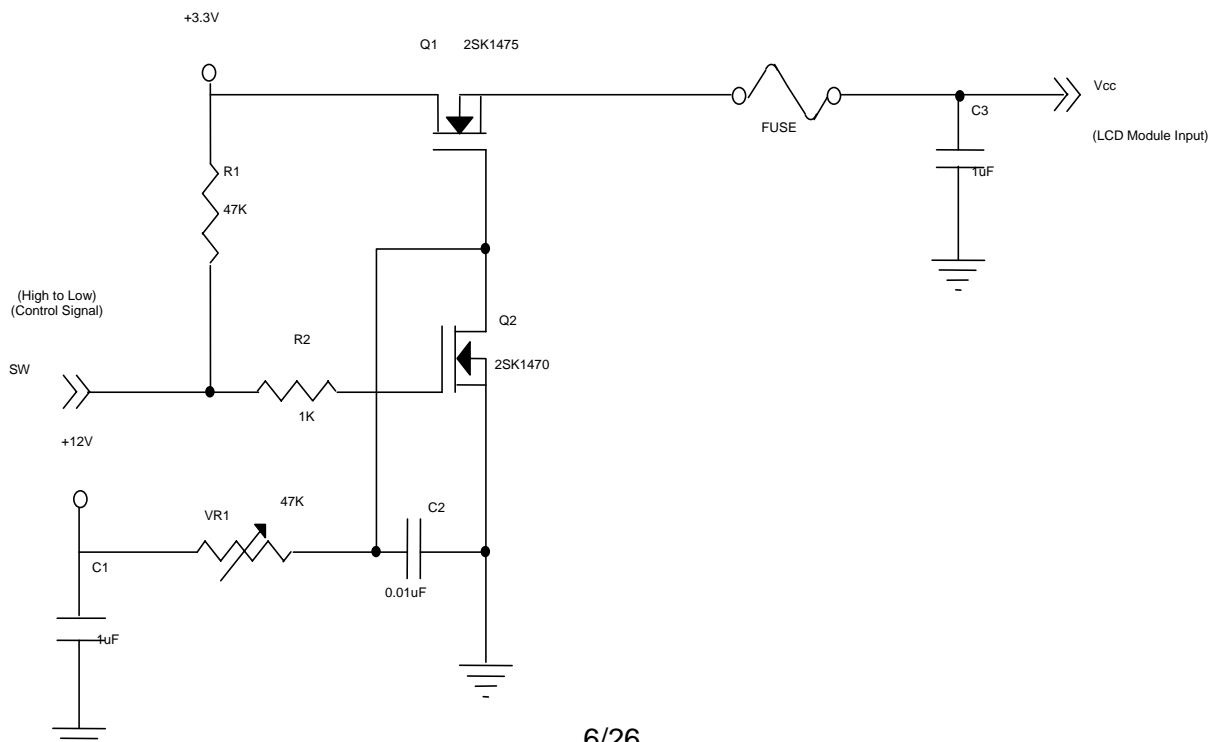

VCC rising time is 470us

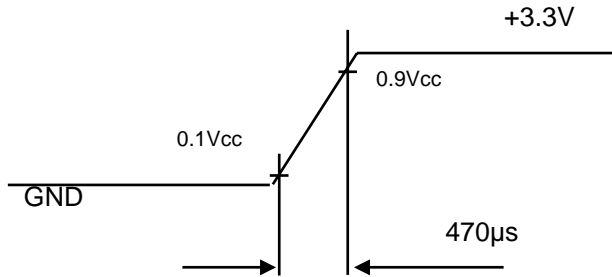

Note (3) The specified power supply current is under the conditions at V<sub>cc</sub> = 3.3 V, T<sub>a</sub> = 25 ± 2 °C, f<sub>v</sub> = 60 Hz, whereas a power dissipation check pattern below is displayed.

a. White Pattern



Active Area

b. Black Pattern

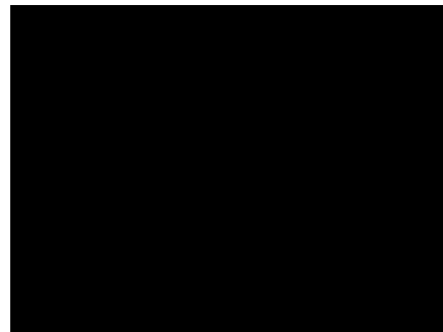

Active Area

c. Vertical Stripe Pattern

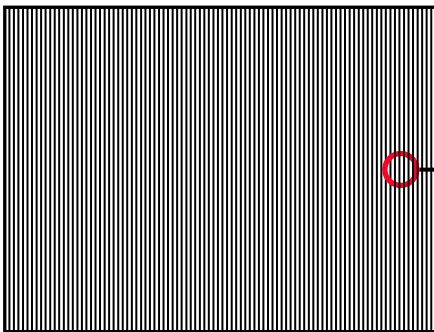

Active Area

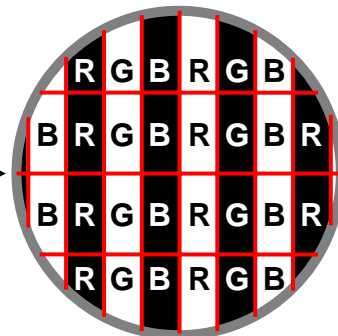

**3.2 LED CONVERTER**
 $T_a = 25 \pm 2 \text{ }^\circ\text{C}$ 

Parameter	Symbol	Value			Unit	Note
		Min.	Typ.	Max.		
Converter Power Supply Voltage	$V_i$	7	12.0	17	V	(Duty 100%)
Converter Power Supply Current	$I_i$	---	0.28	---	A	@ $V_i = 12\text{V}$ (Duty 100%)
LED Power Consumption	$P_{LED}$	---	3.1	---	W	@ $V_i = 12\text{V}$ (Duty 100%)
EN Control Level	Backlight on	2.0	---	3.3	V	
	Backlight off	0	---	0.8	V	
PWM Control Level	PWM High Level	2.0	---	3.3	V	
	PWM Low Level	0	---	0.15	V	
PWM Control Duty Ratio		20		100	%	
PWM Control Frequency	$f_{PWM}$	190	200	210	Hz	
LED Life Time	$L_L$	30,000			Hrs	(2)

Note (1) LED current is measured by utilizing a high frequency current meter as shown below:

Note (2) The lifetime of LED is defined as the time when it continues to operate under the conditions at  $T_a = 25 \pm 2$  and  $I_{LED} = 20\text{mA}_{DC}$  (LED forward current) until the brightness becomes 50% of its original value.

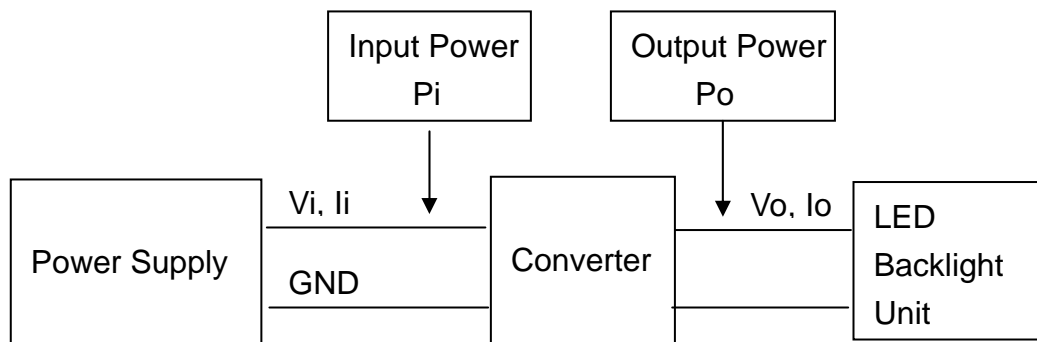



## 4. BLOCK DIAGRAM

### 4.1 TFT LCD MODULE

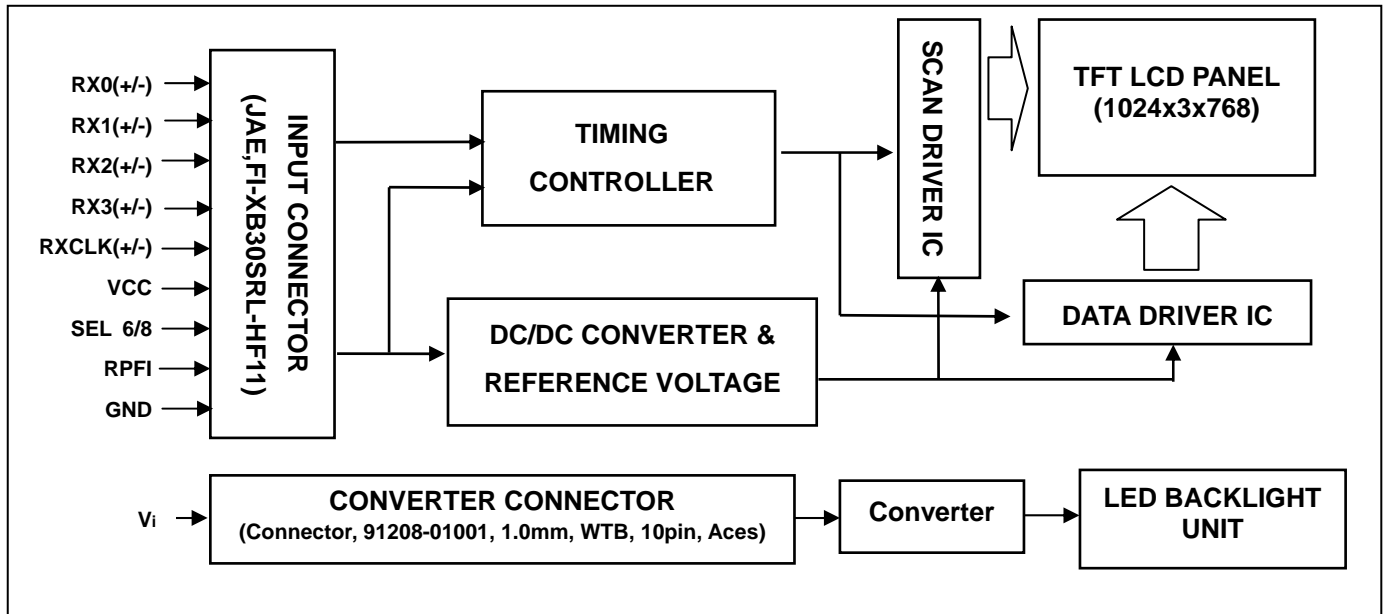

## 5. INTERFACE PIN ASSIGNMENT

### 5.1 TFT LCD MODULE

#### CN1 Connector Pin Assignment

Pin No.	Symbol	Description	Note
1	VCC	Power supply: +3.3V	-
2	VCC	Power supply: +3.3V	-
3	VCC	Power supply: +3.3V	-
4	GND	Ground	-
5	GND	Ground	-
6	GND	Ground	-
7	RPMI	Reverse Panel Function (Display Rotation)	( 2 )
8	NC	No Connection	-
9	NC	No Connection	-
10	NC	No Connection	-
11	SEL6/8	LVDS 6/8 bit select function control, Low or NC → 8 bit Input Mode High → 6bit Input Mode	( 2 )
12	GND	Ground	-
13	NC	No Connection	-
14	GND	Ground	-
15	RX0-	Negative transmission data of pixel 0	-
16	RX0+	Positive transmission data of pixel 0	-
17	GND	Ground	-
18	RX1-	Negative transmission data of pixel 1	-
19	RX1+	Positive transmission data of pixel 1	-
20	GND	Ground	-
21	RX2-	Negative transmission data of pixel 2	-
22	RX2+	Positive transmission data of pixel 2	-
23	GND	Ground	-
24	RXCLK-	Negative of clock	-
25	RXCLK+	Positive of clock	-
26	GND	Ground	-
27	RX3-	Negative transmission data of pixel 3	-
28	RX3+	Positive transmission data of pixel 3	-
29	GND	Ground	-
30	NC	No Connection	( 2 )

Note (1) Connector Part No.: JAE, FI-XB30SRL-HF11 or STARCONN, 093F30-B0B01A

Note (2) "Low" stands for 0V. "High" stands for 3.3V. "NC" stands for "No Connected"

### 5.2 BACKLIGHT UNIT (Converter connector pin)

Pin	Symbol	Description	Remark
1	$V_i$	Converter input voltage	12V
2	$V_i$	Converter input voltage	12V
3	$V_i$	Converter input voltage	12V
4	$V_i$	Converter input voltage	12V
5	$V_{GND}$	Converter ground	Ground
6	$V_{GND}$	Converter ground	Ground
7	$V_{GND}$	Converter ground	Ground
8	$V_{GND}$	Converter ground	Ground
9	EN	Enable pin	3.3V
10	ADJ	Backlight Adjust	PWM Dimming

Note (1) Connector Part No.: 91208-01001(ACES) or equivalent

Note (2) User's connector Part No.: 91209-01011(ACES) or equivalent

### 5.3 COLOR DATA INPUT ASSIGNMENT

The brightness of each primary color (red, green and blue) is based on the 8-bit gray scale data input for the color. The higher the binary input, the brighter the color. The table below provides the assignment of color versus data input.

Color		Data Signal																							
		Red								Green								Blue							
		R7	R6	R5	R4	R3	R2	R1	R0	G7	G6	G5	G4	G3	G2	G1	G0	B7	B6	B5	B4	B3	B2	B1	B0
Basic Colors	Black	0	0	0	0	0	0	0	0	0	0	0	0	0	0	0	0	0	0	0	0	0	0	0	
	Red	1	1	1	1	1	1	1	1	0	0	0	0	0	0	0	0	0	0	0	0	0	0	0	
	Green	0	0	0	0	0	0	0	0	1	1	1	1	1	1	1	1	0	0	0	0	0	0	0	
	Blue	0	0	0	0	0	0	0	0	0	0	0	0	0	0	0	0	1	1	1	1	1	1	1	
	Cyan	0	0	0	0	0	0	0	0	1	1	1	1	1	1	1	1	1	1	1	1	1	1	1	
	Magenta	1	1	1	1	1	1	1	1	0	0	0	0	0	0	0	0	1	1	1	1	1	1	1	
	Yellow	1	1	1	1	1	1	1	1	1	1	1	1	1	1	1	1	0	0	0	0	0	0	0	
	White	1	1	1	1	1	1	1	1	1	1	1	1	1	1	1	1	1	1	1	1	1	1	1	
Gray Scale Of Red	Red(0) / Dark	0	0	0	0	0	0	0	0	0	0	0	0	0	0	0	0	0	0	0	0	0	0		
	Red(1)	0	0	0	0	0	0	0	1	0	0	0	0	0	0	0	0	0	0	0	0	0	0		
	Red(2)	0	0	0	0	0	0	1	0	0	0	0	0	0	0	0	0	0	0	0	0	0	0		
	:	:	:	:	:	:	:	:	:	:	:	:	:	:	:	:	:	:	:	:	:	:	:		
	:	:	:	:	:	:	:	:	:	:	:	:	:	:	:	:	:	:	:	:	:	:	:		
	Red(253)	1	1	1	1	1	1	0	1	0	0	0	0	0	0	0	0	0	0	0	0	0	0		
	Red(254)	1	1	1	1	1	1	1	0	0	0	0	0	0	0	0	0	0	0	0	0	0	0		
	Red(255)	1	1	1	1	1	1	1	1	0	0	0	0	0	0	0	0	0	0	0	0	0	0		
Gray Scale Of Green	Green(0) / Dark	0	0	0	0	0	0	0	0	0	0	0	0	0	0	0	0	0	0	0	0	0	0		
	Green(1)	0	0	0	0	0	0	0	0	0	0	0	0	0	0	1	0	0	0	0	0	0	0		
	Green(2)	0	0	0	0	0	0	0	0	0	0	0	0	0	1	0	0	0	0	0	0	0	0		
	:	:	:	:	:	:	:	:	:	:	:	:	:	:	:	:	:	:	:	:	:	:	:		
	:	:	:	:	:	:	:	:	:	:	:	:	:	:	:	:	:	:	:	:	:	:	:		
	Green(253)	0	0	0	0	0	0	0	0	1	1	1	1	1	1	0	1	0	0	0	0	0	0		
	Green(254)	0	0	0	0	0	0	0	0	1	1	1	1	1	1	1	0	0	0	0	0	0	0		
	Green(255)	0	0	0	0	0	0	0	0	1	1	1	1	1	1	1	1	0	0	0	0	0	0		
Gray Scale Of Blue	Blue(0) / Dark	0	0	0	0	0	0	0	0	0	0	0	0	0	0	0	0	0	0	0	0	0	0		
	Blue(1)	0	0	0	0	0	0	0	0	0	0	0	0	0	0	0	0	0	0	0	0	0	1		
	Blue(2)	0	0	0	0	0	0	0	0	0	0	0	0	0	0	0	0	0	0	0	0	0	1		
	:	:	:	:	:	:	:	:	:	:	:	:	:	:	:	:	:	:	:	:	:	:	:		
	:	:	:	:	:	:	:	:	:	:	:	:	:	:	:	:	:	:	:	:	:	:	:		
	Blue(253)	0	0	0	0	0	0	0	0	0	0	0	0	0	0	0	1	1	1	1	1	1	0		
	Blue(254)	0	0	0	0	0	0	0	0	0	0	0	0	0	0	0	1	1	1	1	1	1	0		
	Blue(255)	0	0	0	0	0	0	0	0	0	0	0	0	0	0	0	1	1	1	1	1	1	1		

Note (1) 0: Low Level Voltage, 1: High Level Voltage

## 6. INTERFACE TIMING

### 6.1 INPUT SIGNAL TIMING SPECIFICATIONS

The input signal timing specifications are shown as the following table and timing diagram.

Signal	Item	Symbol	Min.	Typ.	Max.	Unit	Note
DCLK	Frequency	Fc	55	65	75	MHZ	
Vertical Active Display Term	Total	Tv	770	806	950	Th	Tv=Tvd+Tvb
	Display	Tvd	768	768	768	Th	-
	Blank	Tvb	2	38	182	Th	-
Horizontal Active Display Term	Total	Th	1104	1344	1800	Tc	Th=Thd+Thb
	Display	Thd	1024	1024	1024	Tc	-
	Blank	Thb	76	320	776	Tc	-

Note (1) Since this assembly is operated in DE only mode, Hsync and Vsync input signals should be set to low logic level. Otherwise, this assembly would operate abnormally.

(2) Frame rate is 60Hz

### INPUT SIGNAL TIMING DIAGRAM

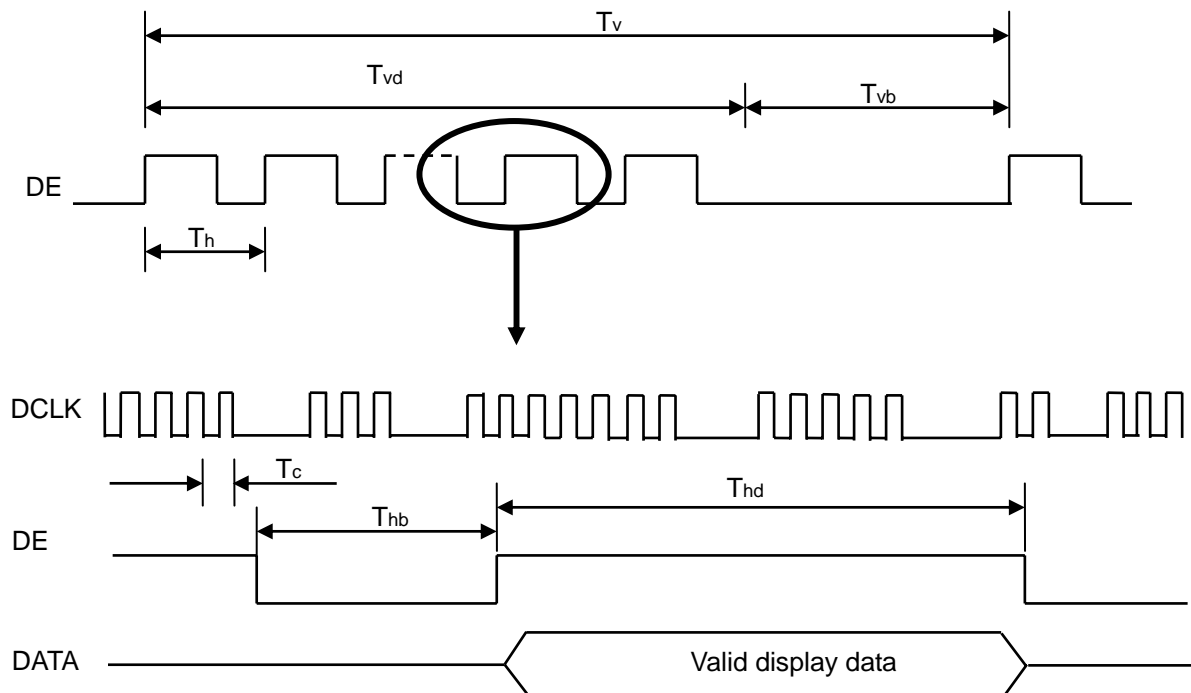

## 6.2 POWER ON/OFF SEQUENCE

To prevent a latch-up or DC operation of LCD assembly, the power on/off sequence should be as the diagram below.

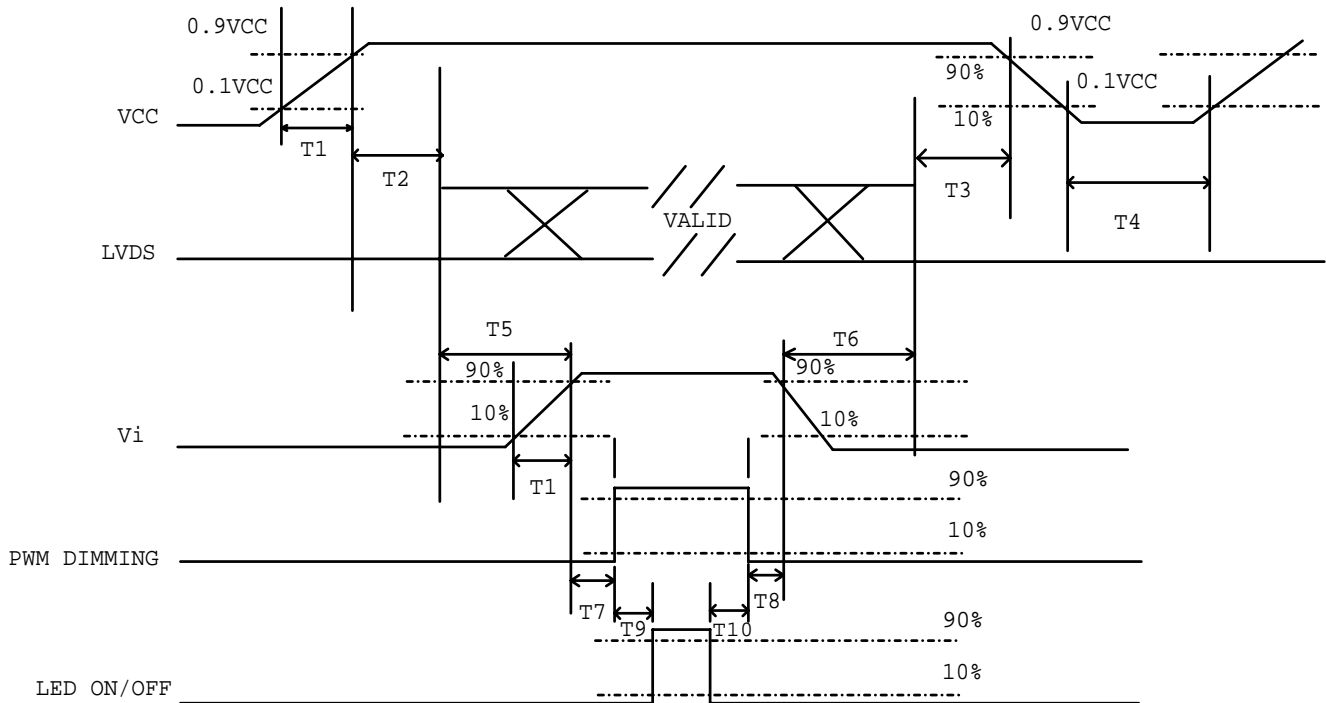

**Power ON/OFF sequence**

Note (1) Please avoid floating state of interface signal at invalid period.

Note (2) When the interface signal is invalid, be sure to pull down the power supply of LCD VCC to 0 V.

Note (3) The Backlight converter power must be turned on after the power supply for the logic and the interface signal is valid. The Backlight converter power must be turned off before the power supply for the logic and the interface signal is invalid.

Parameter	Value			Units
	Min	Typ	Max	
<b>T1</b>	<b>0.5</b>		<b>10</b>	<b>ms</b>
<b>T2</b>	<b>0</b>		<b>50</b>	<b>ms</b>
<b>T3</b>	<b>0</b>		<b>50</b>	<b>ms</b>
<b>T4</b>	<b>500</b>			<b>ms</b>
<b>T5</b>	<b>200</b>			<b>ms</b>
<b>T6</b>	<b>200</b>			<b>ms</b>
<b>T7</b>	<b>10</b>			<b>ms</b>
<b>T8</b>	<b>10</b>			<b>ms</b>
<b>T9</b>	<b>10</b>			<b>ms</b>
<b>T10</b>	<b>0</b>			<b>ms</b>

### 6.3 The Input Data Format

#### SEL 6/8 = "High" for 6 bits LVDS Input

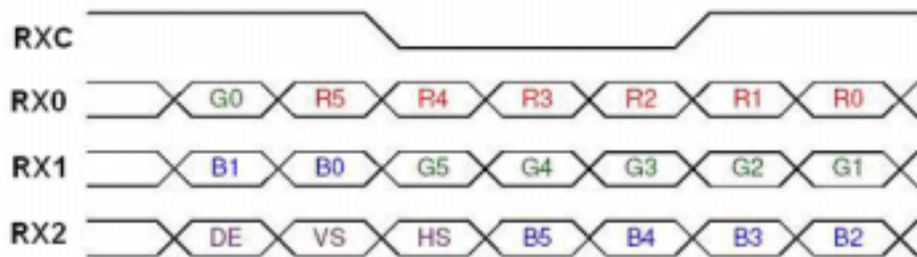

#### SEL 6/8 = "Low" or "NC" for 8 bits LVDS Input

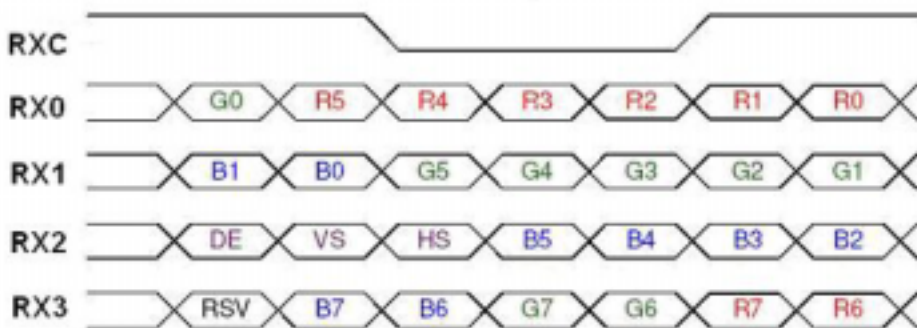

Note (1) R/G/B data 7: MSB, R/G/B data 0: LSB

Note (2) Please follow PSWG

Signal Name	Description	Remark
R7	Red Data 7 (MSB)	Red-pixel Data Each red pixel's brightness data consists of these 8 bits pixel data.
R6	Red Data 6	
R5	Red Data 5	
R4	Red Data 4	
R3	Red Data 3	
R2	Red Data 2	
R1	Red Data 1	
R0	Red Data 0 (LSB)	
G7	Green Data 7 (MSB)	Green-pixel Data Each green pixel's brightness data consists of these 8 bits pixel data.
G6	GreenData 6	
G5	GreenData 5	
G4	GreenData 4	
G3	GreenData 3	
G2	GreenData 2	
G1	GreenData 1	
G0	GreenData 0 (LSB)	
B7	Blue Data 7 (MSB)	Blue-pixel Data Each blue pixel's brightness data consists of these 8 bits pixel data.
B6	Blue Data 6	
B5	Blue Data 5	
B4	Blue Data 4	
B3	Blue Data 3	
B2	Blue Data 2	
B1	Blue Data 1	
B0	Blue Data 0 (LSB)	
RXCLKIN+ RXCLKIN-	LVDS Clock Input	
DE	Display Enable	
VS	Vertical Sync	
HS	Horizontal Sync	

Note (3) Output signals from any system shall be low or Hi-Z state when VCC is off

### 6.4 Scanning Direction

The following figures show the image see from the front view. The arrow indicates the direction of scan.



RPFI = Low/floating; normal display (default)



RPFI = high: display with 180degree rotation

## 7. OPTICAL CHARACTERISTICS

### 7.1 TEST CONDITIONS

Item	Symbol	Value	Unit
Ambient Temperature	T <sub>a</sub>	25±2	°C
Ambient Humidity	H <sub>a</sub>	50±10	%RH
Supply Voltage	V <sub>CC</sub>	5	V
Input Signal	According to typical value in "3. ELECTRICAL CHARACTERISTICS"		
Converter Current	I <sub>L</sub>	20±1mA	mA

### 7.2 OPTICAL SPECIFICATIONS

The relative measurement methods of optical characteristics are shown in 7.2. The following items should be measured under the test conditions described in 7.1 and stable environment shown in Note (6).

Item		Symbol	Condition	Min.	Typ.	Max.	Unit	Note	
Contrast Ratio		CR	θ <sub>x</sub> =0°, θ <sub>y</sub> =0° Viewing angle at normal direction	900	1200	-	-	(2)	
Response Time		T <sub>R</sub>		-	14	19	ms	(3)	
		T <sub>F</sub>		-	11	16	ms		
Center Luminance of White		L <sub>C</sub>		300	350	-	cd/m <sup>2</sup>	(4)	
White Variation		δW		-	-	1.4	-	(7)	
Cross Talk		CT		-	-	4	%	(5)	
Chromaticity	Red	R <sub>x</sub>		Viewing angle at normal direction	Typ. -0.03	0.610	Typ. +0.03	-	(6)
		R <sub>y</sub>				0.365		-	
	Green	G <sub>x</sub>				0.341		-	
		G <sub>y</sub>				0.564		-	
	Blue	B <sub>x</sub>	0.147			-			
		B <sub>y</sub>	0.087			-			
	White	W <sub>x</sub>	0.313			-			
		W <sub>y</sub>	0.329			-			
Viewing Angle	Horizontal	θ <sub>x+</sub>	CR≥10	80	88	-	Deg.	(1)	
		θ <sub>x-</sub>		80	88	-			
	Vertical	θ <sub>y+</sub>		80	88	-			
		θ <sub>y-</sub>		80	88	-			



Note (1) Definition of Viewing Angle ( $\theta_x, \theta_y$ ):

Viewing angles are measured by BM5A

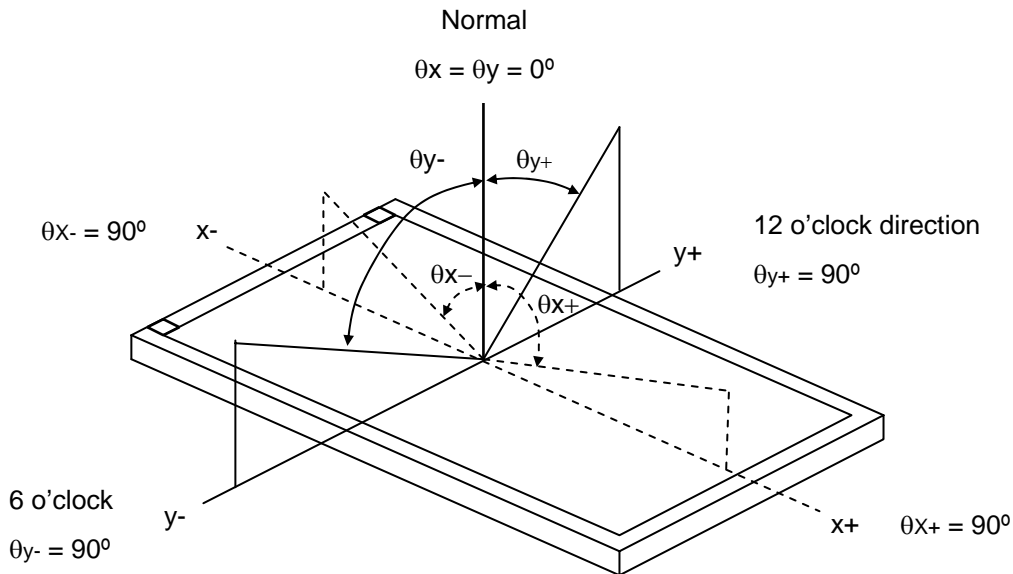

Note (2) Definition of Contrast Ratio (CR):

The contrast ratio can be calculated by the following expression.

$$\text{Contrast Ratio (CR)} = L_{255} / L_0$$

L255: Luminance of gray level 255

L 0: Luminance of gray level 0

CR = CR (5), where CR (X) is corresponding to the Contrast Ratio of the point X at the figure in Note (7).

Note (3) Definition of Response Time ( $T_R, T_F$ ):

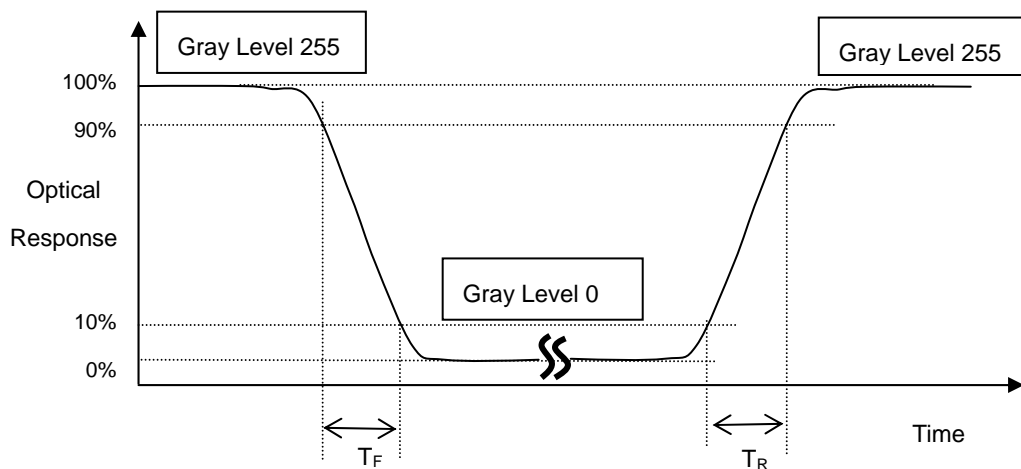

Note (4) Definition of Luminance of White ( $L_C$ ):

Measure the luminance of gray level 255 at center point and 5 points

$L_C = L(5)$ , where  $L(X)$  is corresponding to the luminance of the point  $X$  at the figure in Note (7).

Note (5) Definition of Cross Talk (CT):

$$CT = |Y_B - Y_A| / Y_A \times 100 (\%)$$

Where:

$Y_A$  = Luminance of measured location without gray level 0 pattern ( $cd/m^2$ )

$Y_B$  = Luminance of measured location with gray level 0 pattern ( $cd/m^2$ )

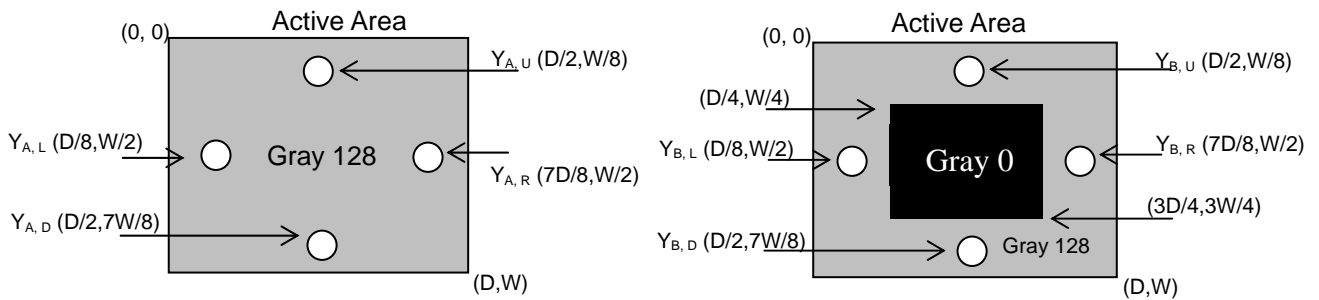

Note (6) Measurement Setup:

The LCD assembly should be stabilized at given temperature for 30 minutes to avoid abrupt temperature change during measuring. In order to stabilize the luminance, the measurement should be executed after lighting Backlight for 30 minutes in a windless room.

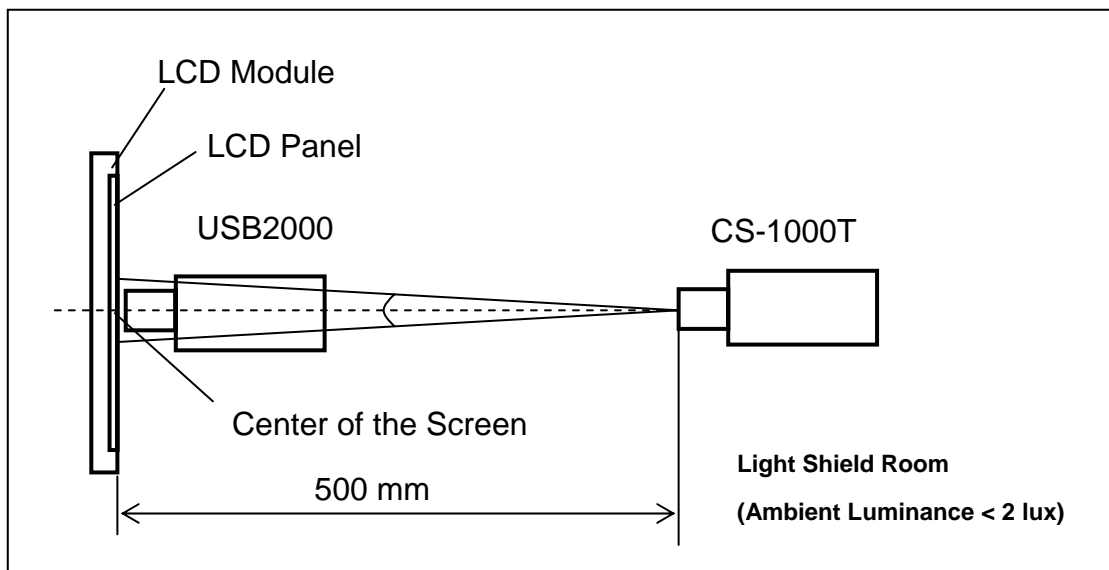

Note (7) Definition of White Variation ( $\delta W$ ):

Measure the luminance of gray level 255 at 5 points

$$\delta W = \text{Maximum } [L(1), L(2), L(3), L(4), L(5)] / \text{Minimum } [L(1), L(2), L(3), L(4), L(5)]$$

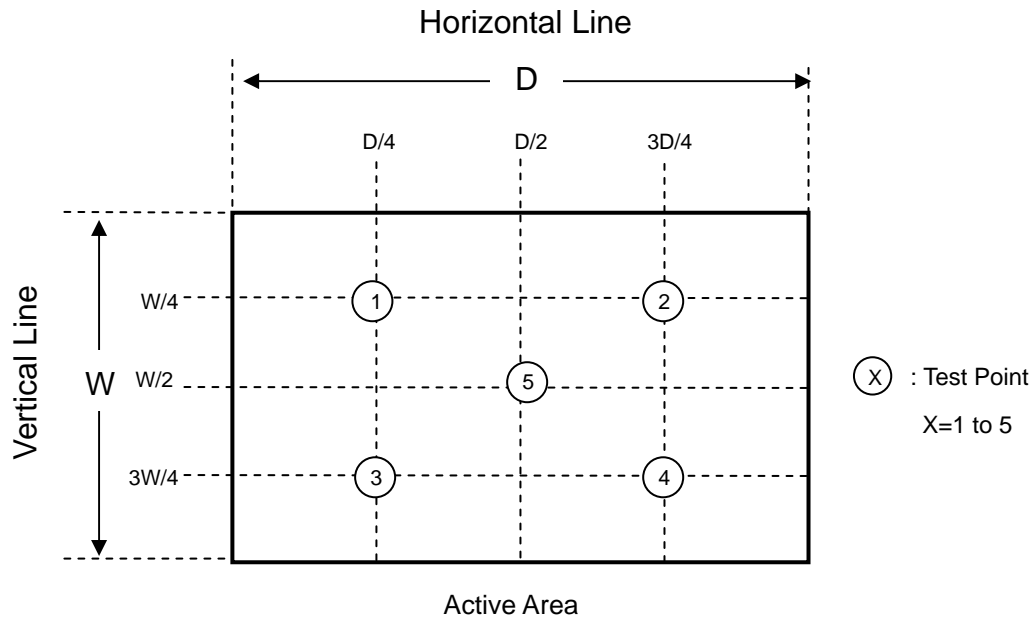

## 8. Reliability Test Criteria

Test Item	Test Condition	Note
High Temperature Storage Test	80°C, 240 hours	(1) (2)
Low Temperature Storage Test	-20°C, 240 hours	
Thermal Shock Storage Test	-20°C, 0.5hour 70 , 0.5hour; 100cycles, 1hour/cycle	
High Temperature Operation Test	70°C, 240 hours	
Low Temperature Operation Test	-20°C, 240 hours	
High Temperature & High Humidity Operation Test	60°C, 90%RH, 240hours	
Shock (Non-Operating)	200G, 2ms, half sine wave, 1 time for $\pm X$ , $\pm Y$ , $\pm Z$ .	(3)
Vibration (Non-Operating)	1.5G, 10 ~ 300 Hz, 10min/cycle, 3 cycles each X, Y, Z	(3)

Note (1) There should be no condensation on the surface of panel during test.

Note (2) Temperature of panel display surface area should be 80 °C Max.

Note (3) At testing Vibration and Shock, the fixture in holding the module has to be hard and rigid enough so that the module would not be twisted or bent by the fixture.

## 9. PACKAGING

### 9.1 PACKING SPECIFICATIONS

- (1) 18pcs LCD modules / 1 Box
- (2) Box dimensions: 465 (L) X 362 (W) X 314 (H) mm
- (3) Weight: approximately 8.3Kg (18 modules per box)

### 9.2 PACKING METHOD

Figures 9-1 and 9-2 are the packing method

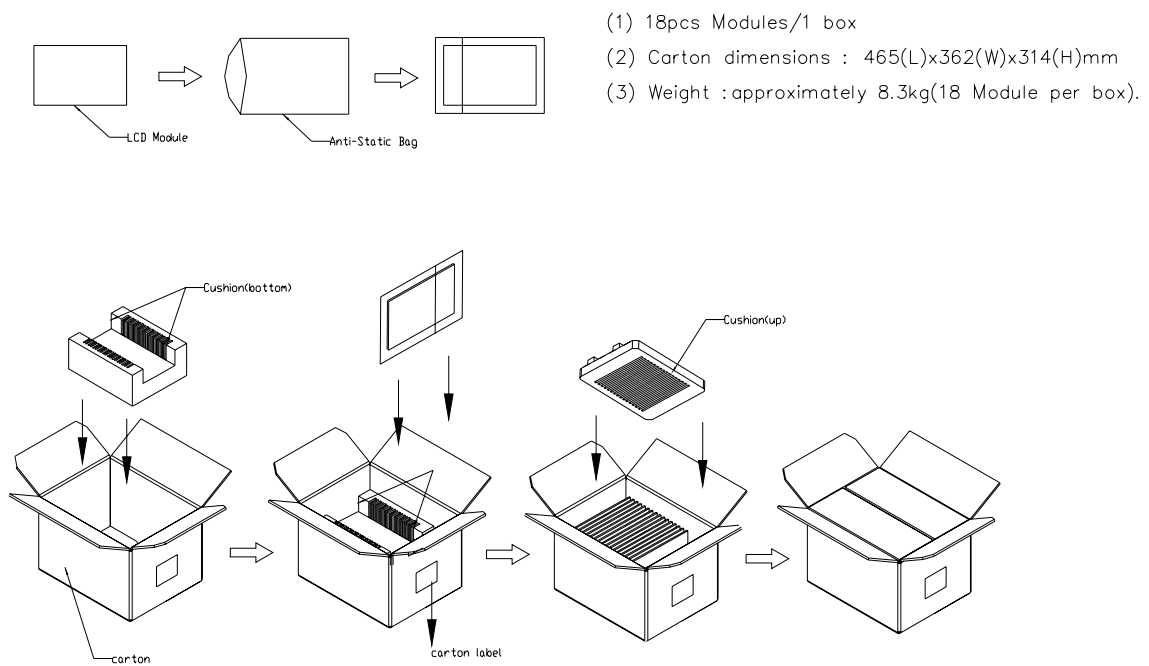

Sea / Land Transportation (40ft Container)

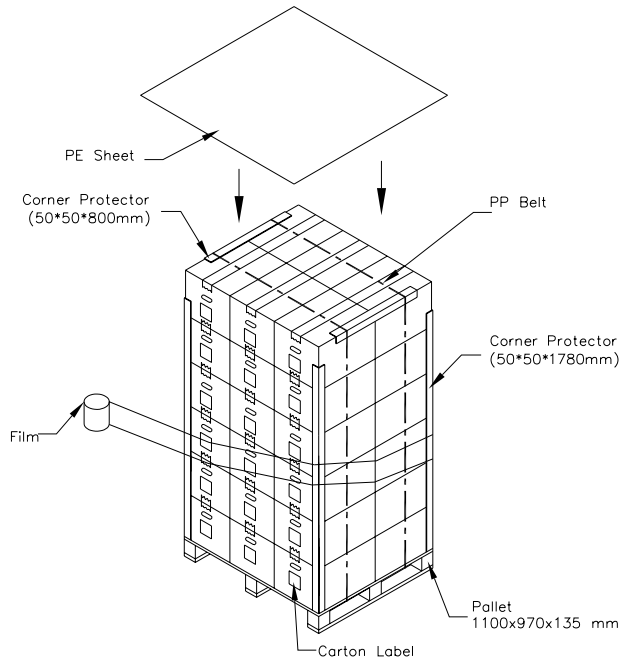

Air Transportation

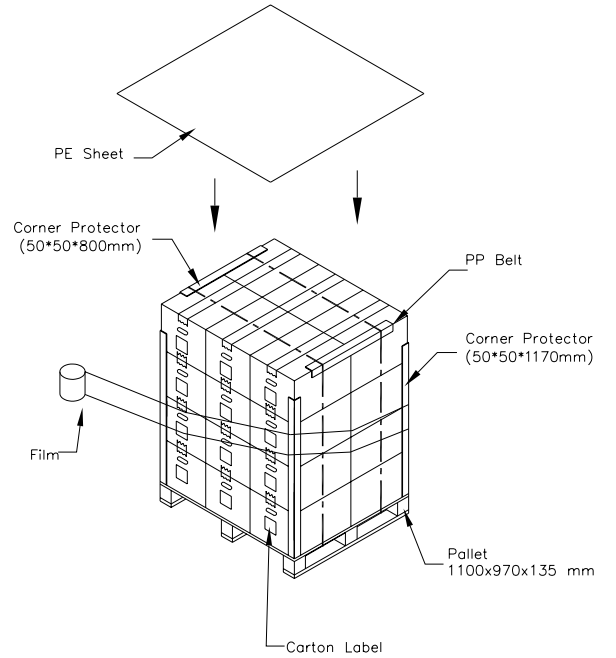
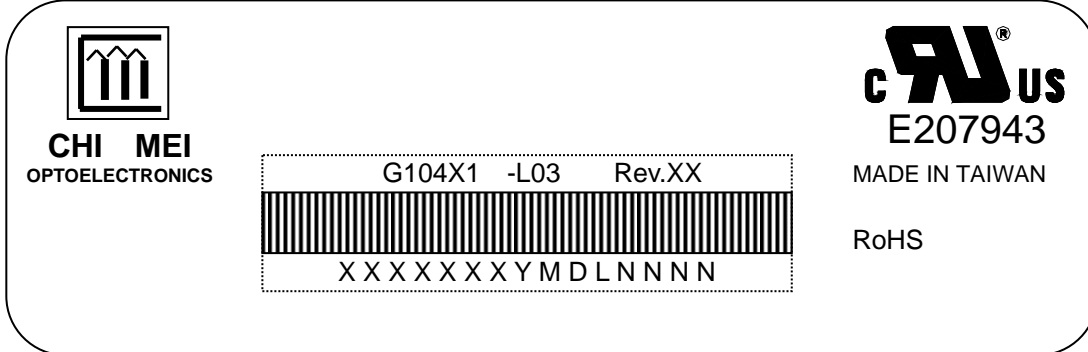

Figure. 9-2 Packing method

## 10. DEFINITION OF LABELS

### 10.1 CMO MODULE LABEL

The barcode nameplate is pasted on each module as illustration, and its definitions are as following explanation.



- (a) Model Name: G104X1-L03
- (b) Revision: Rev. XX, for example: A0, A1... B1, B2... or C1, C2...etc.
- (c) Serial ID: XXXXXXYMDLNNNN

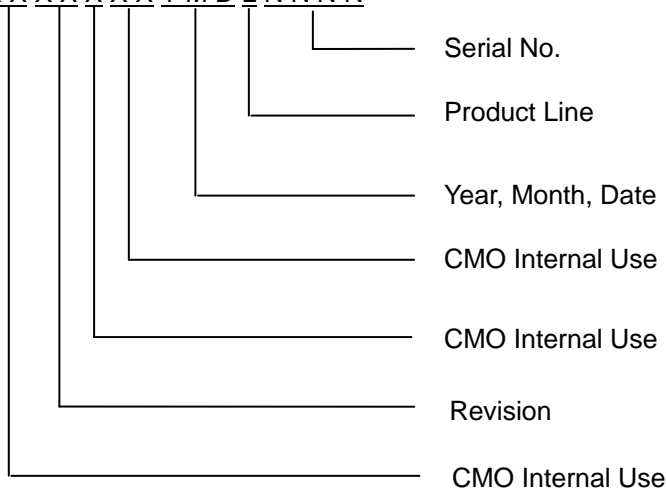

Serial ID includes the information as below:

- (a) Manufactured Date: Year: 0~9, for 2000~2009  
 Month: 1~9, A~C, for Jan. ~ Dec.  
 Day: 1~9, A~Y, for 1<sup>st</sup> to 31<sup>st</sup>, exclude I, O, and U.
- (b) Revision Code: Cover all the change
- (c) Serial No.: Manufacturing sequence of product
- (d) Product Line: 1 -> Line1, 2 -> Line 2, ...etc.

## 11. PRECAUTIONS

### 11.1 ASSEMBLY AND HANDLING PRECAUTIONS

- (1) Do not apply rough force such as bending or twisting to the module during assembly.
- (2) It is recommended to assemble or to install a module into the user's system in clean working areas.  
The dust and oil may cause electrical short or worsen the polarizer.
- (3) Do not apply pressure or impulse to the module to prevent the damage of LCD panel and Backlight.
- (4) Always follow the correct power-on sequence when the LCD module is turned on. This can prevent the damage and latch-up of the CMOS LSI chips.
- (5) Do not plug in or pull out the I/F connector while the module is in operation.
- (6) Do not disassemble the module.
- (7) Use a soft dry cloth without chemicals for cleaning, because the surface of polarizer is very soft and easily scratched.
- (8) Moisture can easily penetrate into LCD module and may cause the damage during operation.
- (9) High temperature or humidity may deteriorate the performance of LCD module. Please store LCD modules in the specified storage conditions.
- (10) When ambient temperature is lower than 10°C, the display quality might be reduced. For example, the response time will become slow, and the starting voltage of backlight will be higher than that of room temperature.
- (11) Do not keep same pattern in a long period of time. It may cause image sticking on LCD.

### 11.2 SAFETY PRECAUTIONS

- (1) The startup voltage of a Backlight is approximately 1000 Volts. It may cause an electrical shock while assembling with the inverter. Do not disassemble the module or insert anything into the Backlight unit.
- (2) If the liquid crystal material leaks from the panel, it should be kept away from the eyes or mouth. In case of contact with hands, skin or clothes, it has to be washed away thoroughly with soap.
- (3) After the module's end of life, it is not harmful in case of normal operation and storage.

## 12. MECHANICAL CHARACTERISTICS



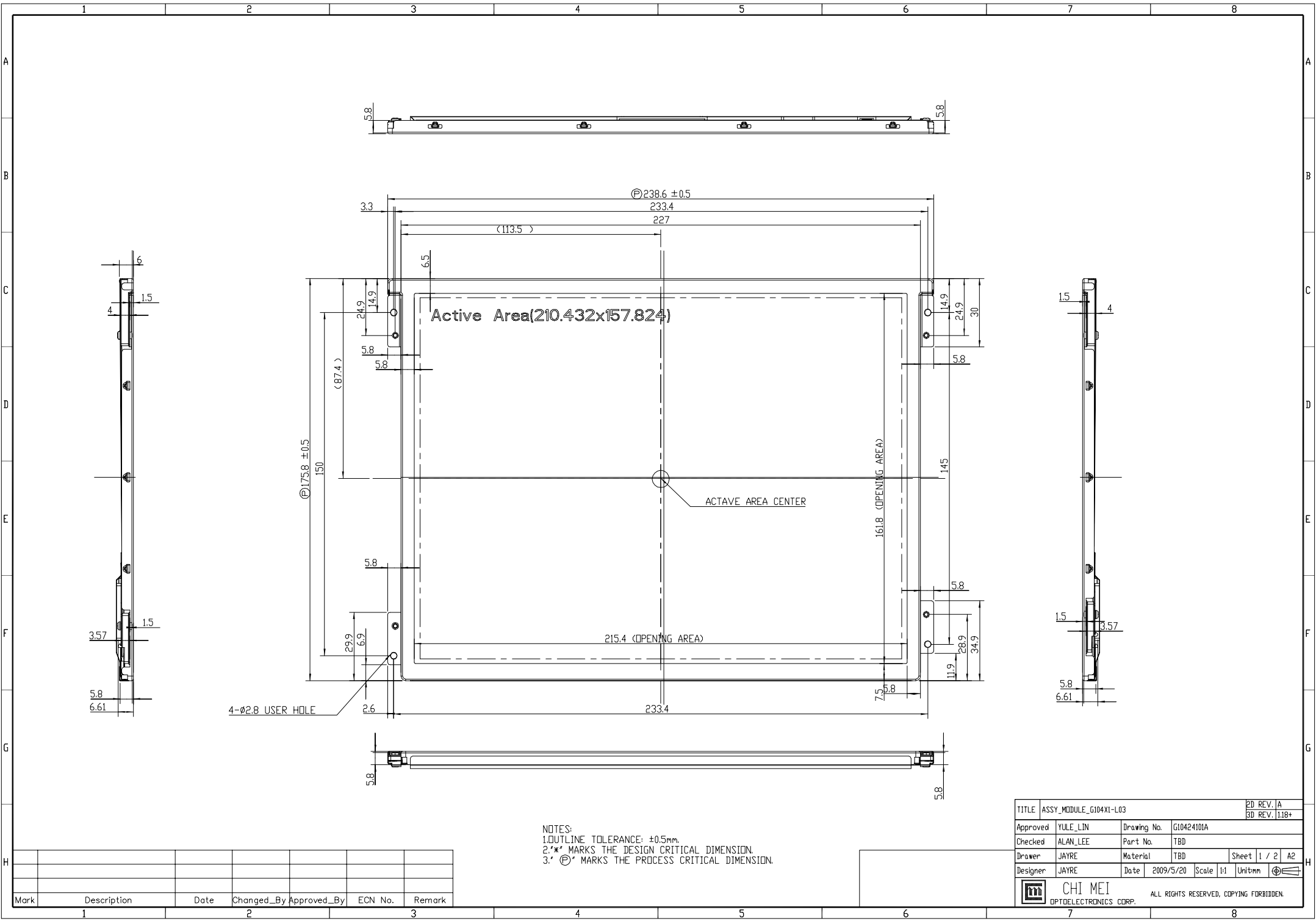

Active Area(210.432x157.824)

ACTIVE AREA CENTER

4-∅2.8 USER HOLE

NOTES:  
 1. OUTLINE TOLERANCE: ±0.5mm.  
 2. \*\* MARKS THE DESIGN CRITICAL DIMENSION.  
 3. \* (P) MARKS THE PROCESS CRITICAL DIMENSION.

Mark	Description	Date	Changed_By	Approved_By	ECN No.	Remark
1						
2						
3						

TITLE		ASSY_MODULE_G104XI-L03		2D REV. A	
Approved		YULE LIN		3D REV. 118+	
Checked		ALAN LEE		Drawing No. G10424101A	
Drawer		JAYRE		Part No. TBD	
Designer		JAYRE		Material TBD	
Date		2009/5/20		Sheet 1 / 2 A2	
Scale		1:1		Unit: mm	
		CHI MEI		ALL RIGHTS RESERVED, COPYING FORBIDDEN.	
		OPTOELECTRONICS CORP.			