



## | 9960 SERIES

### HALL EFFECT SENSOR



### Introduction

Model 9960 Hall effect rotary position sensors are available in numerous standard configurations with fast, one week delivery. Available configurations include 7 termination options, single or dual outputs and 24 active electrical angles. With 360 degree turn capability, the 9960 can be used over a large range of rotary motion making it extremely versatile.

Packaged in a highly sealed (IP69K) housing and utilizing non-contacting Hall effect technology makes the 9960 an exceptionally rugged and reliable sensor. Model 9960 is ideal for a variety of applications in harsh environments, including steering and pedal positioning for construction, agriculture and mining vehicles, marine steering and speed control, wheel and throttle position for material handling equipment, and valve position for process control.



## SPECIFICATIONS

### Mechanical

<b>Mechanical Travel</b>	Continuous 360 degree and option for 180 degree mechanical stops
<b>Operating Torque</b>	0.11 N-m maximum
<b>Weight</b>	80 g (w/ 6" cable)
<b>Mounting</b>	38mm mounting center
<b>Drive</b>	Blade Ø9.53 x 2.16 wide
<b>Termination</b>	Flying leads, wire harness w/connector or integral connector (see ordering options)

### Electrical

<b>Active Electrical Angle</b>	15°-360° in 15° increments (no spring)
<b>Input Voltage</b>	5VDC ±5%, 9-30VDC or 15-30VDC
<b>Input Current</b>	(per channel) 16mA maximum except for Current Loop option at 36mA max
<b>Overvoltage</b>	5V Input: 20VDC 9-30V Input: 70V per ISO 7637-2
<b>Output Signal</b>	<b>Analog:</b> 1) ratiometric 5% to 95% or 10% to 90% 2) non-ratiometric 0-10VDC, 0-5VDC, 0.5-4.5VDC
	<b>PWM:</b> duty cycle 5% to 95% or 10% to 90%
	<b>Current:</b> 4-20 mA (3-wire)
<b>Output Load</b>	<b>Analog &amp; PWM:</b> 10kOhm resistive minimum
	<b>Current:</b> 4000hm resistive maximum
<b>Resolution</b>	0.088 degrees (12-bit)
<b>Accuracy</b>	±0.6% of Active Electrical Angle at room temperature ±0.9% of Active Electrical Angle at temperature

<b>EMC</b>	200 V/m
<b>External Magnetic Susceptibility</b>	20G

**Environmental**

<b>Sealing</b>	IP67, IP69K
<b>Side Load</b>	1kg (1 million cycles)
<b>Temperature Range</b>	<b>Operating Temperature:</b> -40°C to +125°C 4-20mA versions 9J, 9K, & 9X1: -40°C to 85°C
	<b>Storage Temperature:</b> -55°C to +150°C
<b>Mechanical Resistance</b>	<b>Vibration:</b> 10G peak, 10-2000 Hz
	<b>Shock:</b> 50Gs, half sine pulse, 11 m sec duration



**DIMENSIONS**

All dimensions are in INCHES [MM].  
Tolerances unless otherwise noted.. X.XX= ± .012 [±0.3] X.XXX= ± .005[±0.13]

**SL, DL, OPTION**

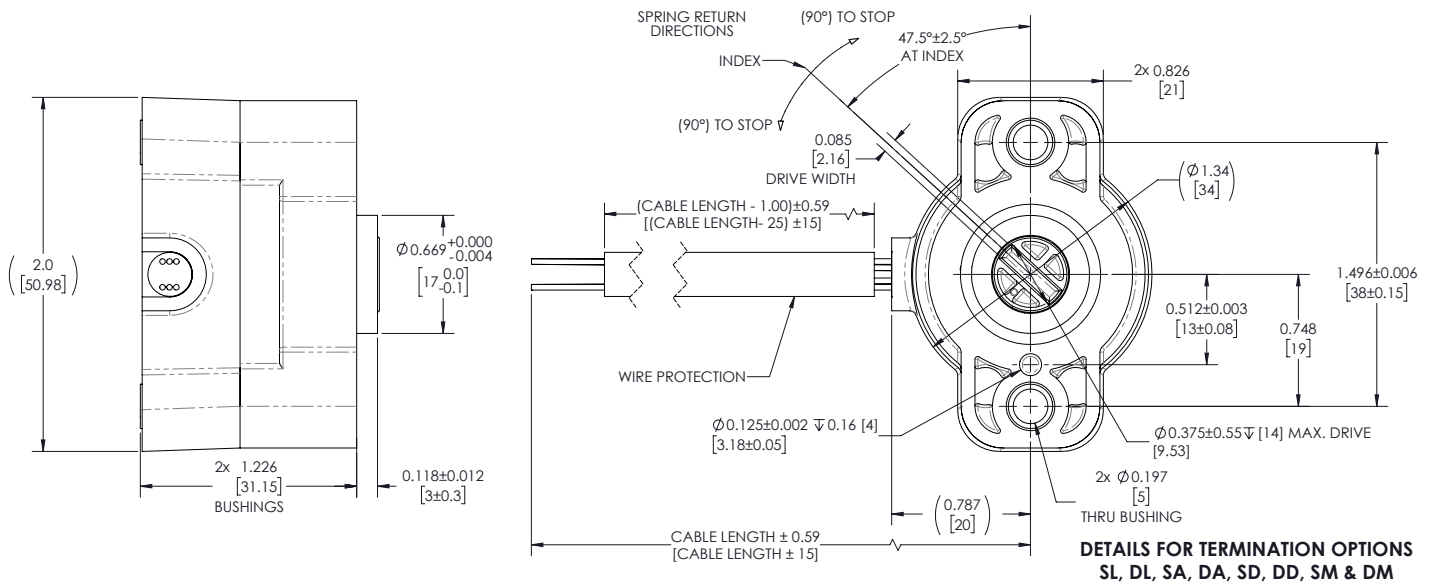

# SW OPTION

For other pinout options refer to the pinout and connector sections following the ordering options on the pages following

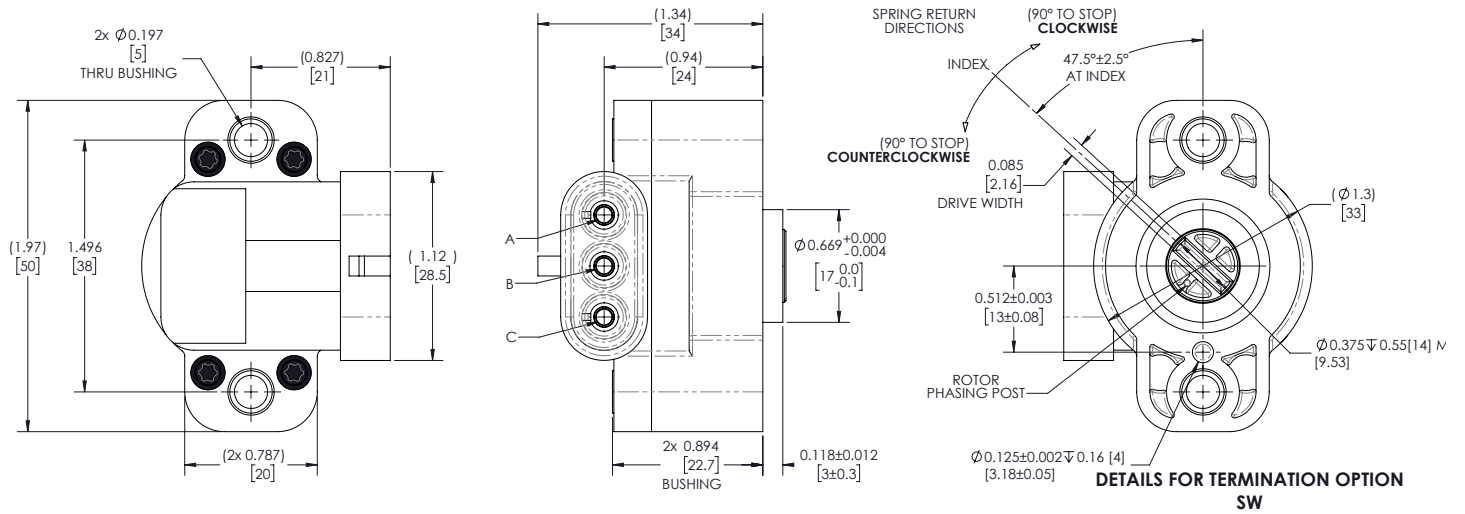

## OUTPUT WAVEFORMS

(OPTION 5A WITH 90° ELECTRICAL ANGLE SHOWN)

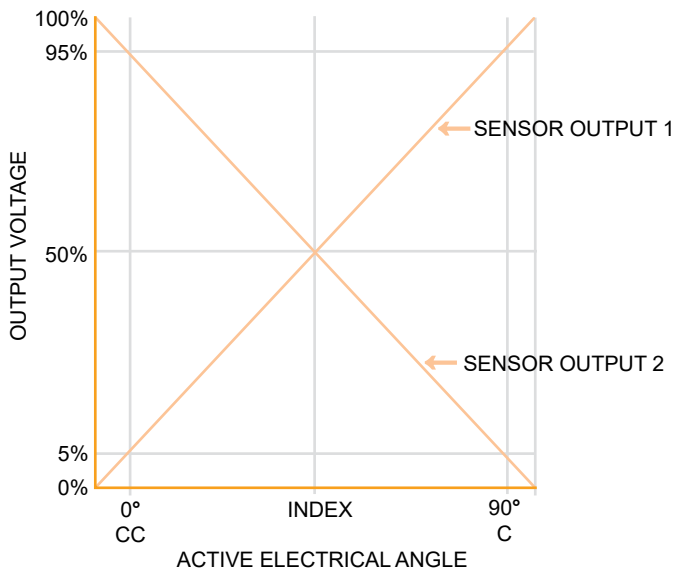

## PIN OUT DRAWINGS

All dimensions are in INCHES [MM].

1 (DD)

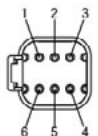

2 (SD)

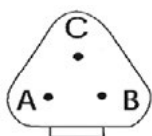

3 (DA)

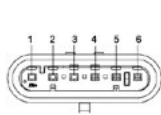

4 (SA)

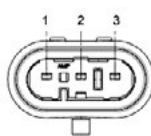

5 (DM)

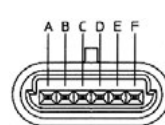

6 (SM)

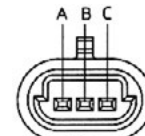

7 (SW)

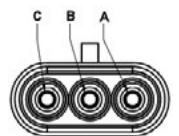



## CONNECTOR PIN OUT

Dwg 1	Dwg 2	Dwg 3	Dwg 4	Dwg 5	Dwg 6	Dwg 7	Flying Lead	Flying Lead		
Pin Number							3-Wire	6-Wire	Wire Color	Function
1	A	1	1	E	A	A	•	•	Brown	GND 1
2	B	2	2	F	B	C	•	•	Red	Supply Voltage 1
3	C	3	3	C	C	B	•	•	Orange	Sensor 1 Output
4		4		A				•	Green	Ground 2
5		5		B				•	Blue	Supply Voltage 2
6		6		D				•	Yellow	Sensor 2 Output



## CONNECTOR PART NUMBERS AND MATES

Dwg	Connector	Mates to
1	Deutsch: DT04-6P	DT06-6S
2	Deutsch: DT04-3P	DT06-3S
3	Amp Superseal: 1.5V; 282108-1	282090-1
4	Amp Superseal: 1.5V; 282105-1	282087-1
5	Packard Electric Metripack 150.2	12162210
6	Packard Electric Metripack 150.2	12162182
7	Packard Electric Weather Pack	12015793



# ORDERING OPTIONS

Use this diagram, working from left to right to construct your model number

(PWM example: 9960-015-C-5EP1-SL150)  
(Ratiometric example: 9960-180-NS-SA-DD300)  
(Reprogrammable example: 9960-X-C-9X2-DA450)

9960

## Family

9960

## Standard Electrical Angles

**Standard Angles:** 015, 030, 045, 060, 075, 090, 105, 120, 135, 150, 165, 180, 195, 210, 225, 240, 255, 270, 285, 300, 315, 330, 345, 360  
**X:** Programmable Angle (used with I/O options 5X1, 5X2, 9X1, 9X2, 15X)  
NOTE: Other angles available, (Ex: 015 = 15°±7.5; 360 = 360°±180) consult factory

## Spring/ Rotor Return Direction

**C:** CLOCKWISE SPRING RETURN\*  
**CC:** COUNTERCLOCKWISE SPRING RETURN\*  
**NS:** NO SPRING RETURN, CONTINUOUS ROTATION  
\* Spring return: available for active electrical angles 15° to 165°, not available from 180° to 360°.

## Input/ Output (I/O)

### 5 VDC IN, Ratiometric Voltage OUT

**5A:** SENSOR1: 5% to 95%; SENSOR2: 95% to 5%  
**5B:** SENSOR1: 95% to 5%; SENSOR2: 5% to 95%  
**5C:** SENSOR1: 10% to 90%; SENSOR2: 90% to 10%  
**5D:** SENSOR1: 90% to 10%; SENSOR2: 10% to 90%  
**5X1:** SENSOR1 and SENSOR2: Programmable

### 5 VDC IN, PWM OUT

**5E:** SENSOR1: 5% to 95%; SENSOR2: 95% to 5%  
**5F:** SENSOR1: 95% to 5%; SENSOR2: 5% to 95%  
**5G:** SENSOR1: 10% to 90%; SENSOR2: 90% to 10%  
**5H:** SENSOR1: 90% to 10%; SENSOR2: 10% to 90%  
**5X2:** SENSOR1 and SENSOR2: Programmable

### 9-30 VDC IN, CURRENT OUT\*\*

**9J:** SENSOR1: 4-20 mA; SENSOR2: 20-4 mA

**9K:** SENSOR1: 20-4 mA, SENSOR2: 4-20 mA

**9X1:** SENSOR1 and SENSOR2: Programmable

### 9-30 VDC IN, VOLTAGE OUT\*\*

**9L:** SENSOR1: 0-5 VDC, SENSOR2: 5-0 VDC  
**9M:** SENSOR1: 5-0 VDC, SENSOR2: 0-5 VDC  
**9N:** SENSOR1: 0.5-4.5 VDC, SENSOR2: 4.5-0.5 VDC  
**9R:** SENSOR1: 4.5-0.5 VDC, SENSOR2: 0.5-4.5 VDC  
**9X2:** SENSOR1 and SENSOR2: Programmable  
**15-30 VDC IN, VOLTAGE OUT**  
**15S:** SENSOR1: 0-10 VDC, SENSOR2: 10-0 VDC  
**15T:** SENSOR1: 10-0 VDC, SENSOR2: 0-10 VDC  
**15X:** SENSOR1 and SENSOR2: Programmable\*\*  
NOTE: Output with clockwise rotation of rotor.  
SENSOR1 specifies single SENSOR option

## PWM Frequency

(Used with 5E, 5F, 5G, 5H and 5X2 I/O options only; leave blank for other output options)

**P1:** 100 Hz  
**P2:** 200 Hz  
**P3:** 500 Hz  
**P4:** 1000 Hz

## Number of Outputs and Termination Options

**SL:** Single Output, Flying Leads  
**DL:** Dual Output, Flying Leads  
**SA:** Single Output, Cable W/Tyco AMP Superseal 1.5 Series\*  
**DA:** Dual Output, CableW/ Tyco AMP Superseal 1.5 Series \*  
**SD:** Single Output, Cable W/Deutsh DT04 Series \*  
**DD:** Dual Output, Cable W/Deutsh DT04 Series \*  
**SM:** Single Output, Cable W/ Packard Electric Metripack 150 Series\*  
**DM:** Dual Output, Cable W/ Packard Electric Metripack 150 Series\*  
**SW:** Single Output, Integral 3-PIN Weatherpack Connector (no cable length necessary)\*\*

\* Single Outputs= 3-PIN, Dual Output= 6-PIN  
\*\*SW not available on 9-30 VDC IN, Current Out; 9-30 VDC IN, Voltage Out and 15X specification.

## Cable Length

**150:** 150mm (~6 inches)  
**300:** 300mm (~12 inches)  
**450:** 450mm (~18 inches)  
NOTE: Other lengths available, consult factory

## Wire protection

**Blank:** No Wire protection  
**C:** Convoluted tubing  
**T:** Shrinkable tubing