

Description

The 9DBL02x3/9DBL04x3/ 9DBL06x3/9DBL08x3 buffers are low-power, high-performance members of Renesas' full featured PCIe family. The buffers support PCIe Gen1–5 and provide a Loss of Signal (LOS) indicator.

PCIe Clocking Architectures

- Common Clocked (CC)
- Independent Reference (IR) with/without SSC (SRIS, SRNS)

Typical Applications

- PCIe Riser Cards
- nVME Storage
- Networking
- Accelerators
- Industrial Control/Embedded

Key Specifications

- Additive PCIe Gen5 CC jitter < 60fs RMS (fanout mode)
- PCIe Gen5 CC jitter < 150fs RMS (High-BW ZDB Mode)

Features

- LOS open-drain output indicates loss of input clock
- 2 to 8 Low-Power HCSL (LP-HCSL) outputs eliminate 4 resistors per output pair
- 9DBLxx4x devices provide integrated 100Ω terminations
- 9DBLxx5x devices provide integrated 85Ω terminations
- See [AN-891](#) for easy coupling to other logic families
- Spread-spectrum compatible
- Dedicated OE# pin for each output
- 1MHz to 200MHz operation in fan-out mode
- 3 selectable SMBus addresses
- Extensive SMBus-selectable features allow optimization to customer requirements
- SMBus interface not required for device operation
- -40°C to +85°C operating temperature range
- Space-saving 4 × 4 mm 24-VFQFPN to 6 × 6 mm 48-VFQFPN packages (see [Ordering Information](#) table for details)

Block Diagram

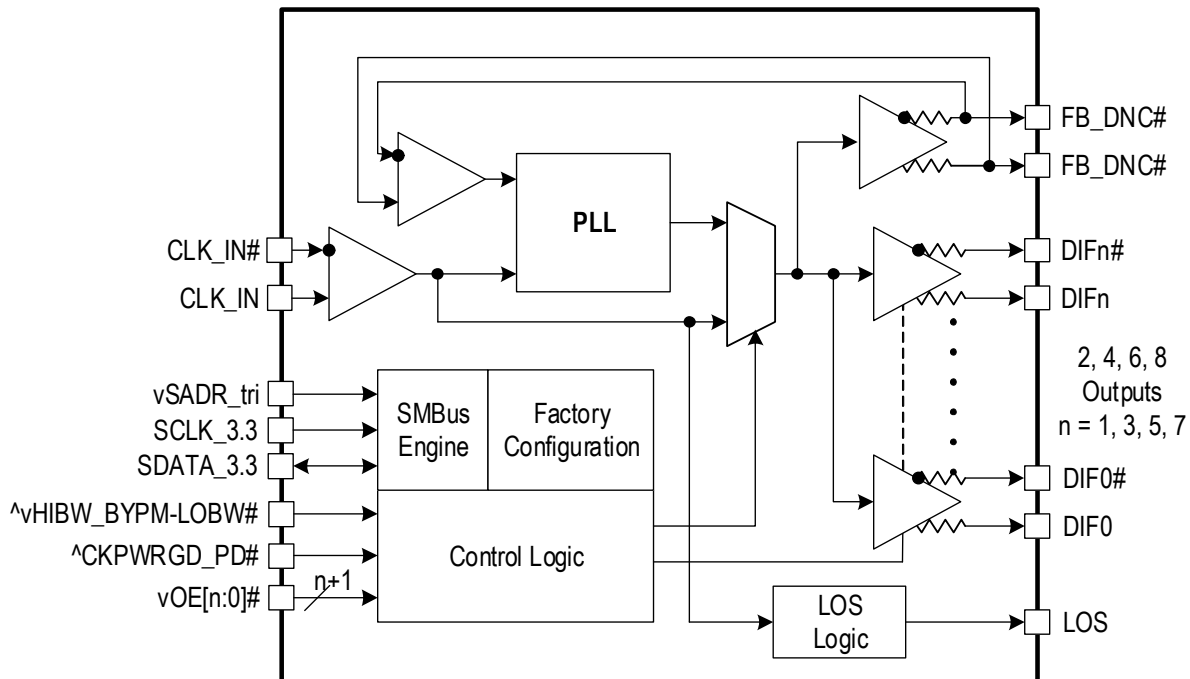

Contents

Description	1
PCIe Clocking Architectures	1
Typical Applications	1
Key Specifications	1
Features	1
Block Diagram	1
Pin Assignments	3
9DBL02x3 Pin Assignment	3
9DBL04x3 Pin Assignment	3
9DBL06x3 Pin Assignment	4
9DBL08x3 Pin Assignment	4
Pin Descriptions	5
Absolute Maximum Ratings	7
Electrical Characteristics	8
Power Management	14
ZDB Operating Mode	14
Test Loads	15
General SMBus Serial Interface Information	16
How to Write	16
How to Read	16
Package Outline Drawings	24
Thermal Characteristics	24
Marking Diagrams	25
9DBL02x3	25
9DBL04x3	25
9DBL06x3	25
9DBL08x3	25
Ordering Information	26
Revision History	27

Pin Assignments

9DBL02x3 Pin Assignment

Figure 1. Pin Assignment for 4 × 4 mm 24-VFQFPN Package – Top View

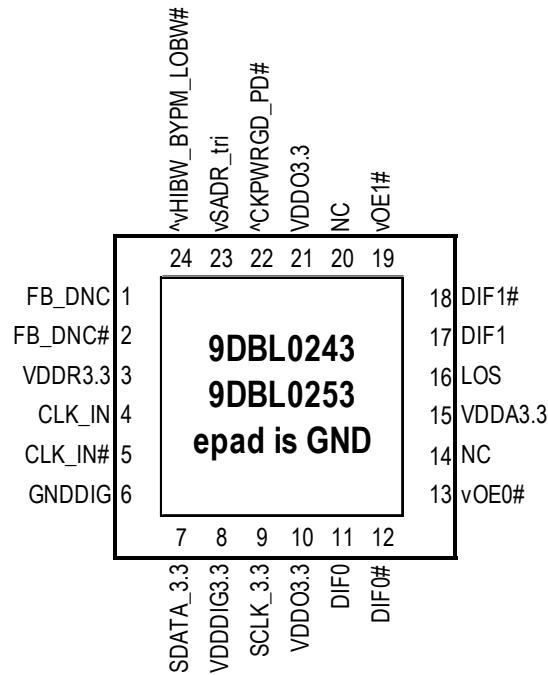

9DBL04x3 Pin Assignment

Figure 2. Pin Assignment for 5 × 5 mm 32-VFQFPN Package – Top View

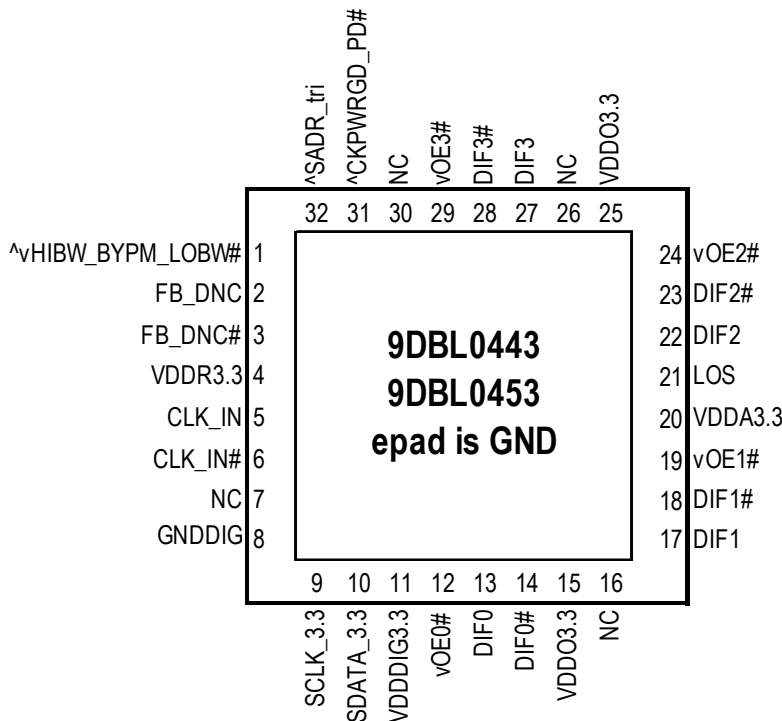

9DBL06x3 Pin Assignment

Figure 3. Pin Assignment for 5 × 5 mm 40-VFQFPN Package – Top View

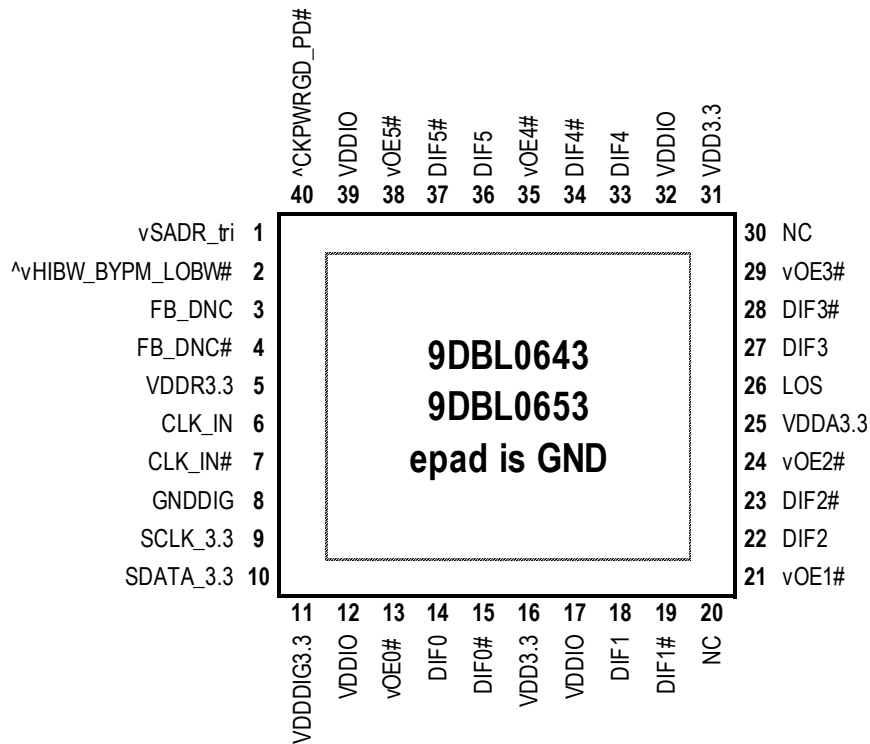

9DBL08x3 Pin Assignment

Figure 4. Pin Assignment for 6 × 6 mm 48-VFQFPN Package – Top View

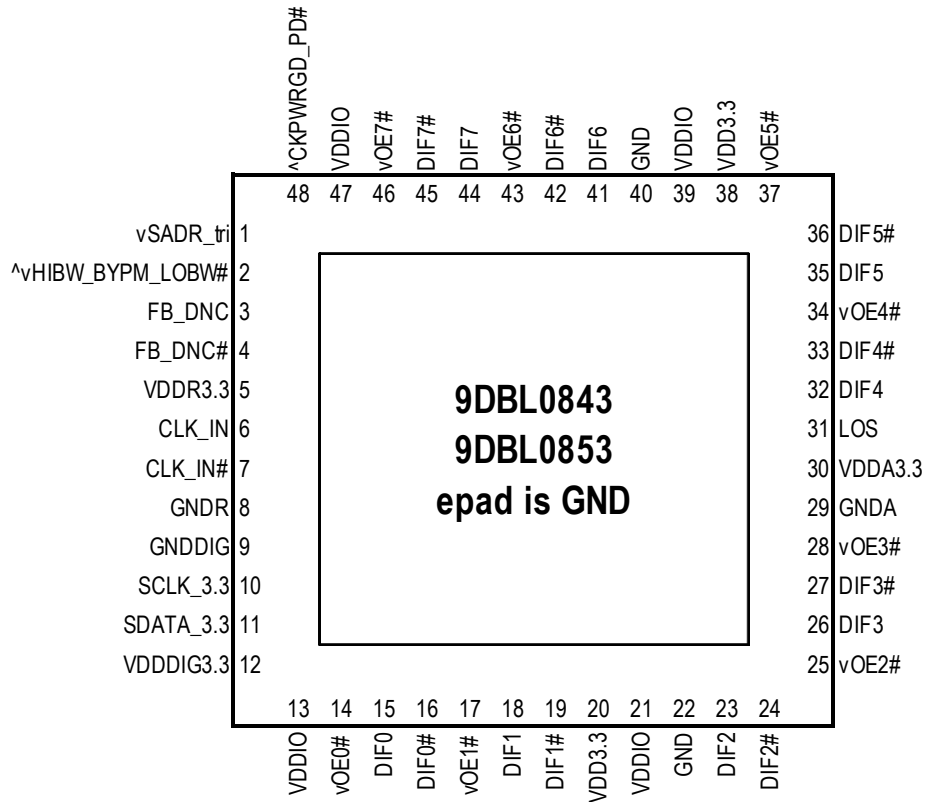

Pin Descriptions

Table 1. Pin Descriptions

Pin Name [a] [b] [c]	Type	Description	08x3 Pin No.	06x3 Pin No.	04x3 Pin No.	02x3 Pin No.
^CKPWRGD_PD#	Input	Input notifies device to sample latched inputs and start up on first high assertion. Low enters Power Down Mode, subsequent high assertions exit Power Down Mode. This pin has internal 120kΩ pull-up resistor.	48	40	31	22
^vHIBW_BYPM_LOBW#	Latched In	Tri-level input to select High BW, Bypass or Low BW mode. This pin is biased to VDD/2 (Bypass mode) with internal pull-up/pull-down resistors. See ZDB Operating Mode for details.	2	2	1	24
CLK_IN	Input	True Input for differential reference clock.	6	6	5	4
CLK_IN#	Input	Complementary input for differential reference clock.	7	7	6	5
DIF0	Output	Differential true clock output.	15	14	13	11
DIF0#	Output	Differential complementary clock output.	16	15	14	12
DIF1	Output	Differential true clock output.	18	18	17	17
DIF1#	Output	Differential complementary clock output.	19	19	18	18
DIF2	Output	Differential true clock output.	23	22	22	–
DIF2#	Output	Differential complementary clock output.	24	23	23	–
DIF3	Output	Differential true clock output.	26	27	27	–
DIF3#	Output	Differential complementary clock output.	27	28	28	–
DIF4	Output	Differential true clock output.	32	33	–	–
DIF4#	Output	Differential complementary clock output.	33	34	–	–
DIF5	Output	Differential true clock output.	35	36	–	–
DIF5#	Output	Differential complementary clock output.	36	37	–	–
DIF6	Output	Differential true clock output.	41	–	–	–
DIF6#	Output	Differential complementary clock output.	42	–	–	–
DIF7	Output	Differential true clock output.	44	–	–	–
DIF7#	Output	Differential complementary clock output.	45	–	–	–
EPAD	GND	Connect to ground.	49	41	33	25
FB_DNC	DNC	True clock of differential feedback. The feedback output and feedback input are connected internally on this pin. Do not connect anything to this pin.	3	3	2	1
FB_DNC#	DNC	Complement clock of differential feedback. The feedback output and feedback input are connected internally on this pin. Do not connect anything to this pin.	4	4	3	2
GND	GND	Ground pin.	22	–	–	–
GND	GND	Ground pin.	40	–	–	–
GND A	GND	Ground pin for the PLL core.	29	–	–	–
GND DIG	GND	Ground pin for digital circuitry.	9	8	8	6

Table 1. Pin Descriptions (Cont.)

Pin Name [a] [b] [c]	Type	Description	08x3 Pin No.	06x3 Pin No.	04x3 Pin No.	02x3 Pin No.
GNDR	GND	Analog ground pin for the differential input (receiver)	8	–	–	–
LOS	Open Drain Out	Output indicating Loss of Input Signal. This pin is an open drain output and requires an external pull-up resistor for proper functionality. The pin is normally pulled low and goes high when the input clock is not present.	31	26	21	16
NC	N/A	No connection.	–	20, 30	7, 16, 26, 30	14, 20
SCLK_3.3	Input	Clock pin of SMBus circuitry, 3.3V tolerant.	10	9	9	9
SDATA_3.3	I/O	Data pin for SMBus circuitry, 3.3V tolerant.	11	10	10	7
VDD3.3	Power	Power supply, nominal 3.3V.	20	16	–	–
VDD3.3	Power	Power supply, nominal 3.3V.	38	31	–	–
VDDA3.3	Power	3.3V power for the PLL core.	30	25	20	15
VDDDIG3.3	Power	3.3V digital power (dirty power).	12	11	11	8
VDDIO	Power	Power supply for differential outputs.	13, 21, 39, 47	12, 17, 32, 39	–	–
VDDO3.3	Power	Power supply for outputs. Nominally 3.3V.	–	–	15, 25	10, 21
VDDR3.3	Power	3.3V power for differential input clock (receiver). This VDD should be treated as an Analog power rail and filtered appropriately.	5	5	4	3
vOE0#	Input	Active low input for enabling output 0. This pin has an internal 120kΩ pull-down. 1 = disable outputs, 0 = enable outputs	14	13	12	13
vOE1#	Input	Active low input for enabling output 1. This pin has an internal 120kΩ pull-down. 1 = disable outputs, 0 = enable outputs	17	21	19	19
vOE2#	Input	Active low input for enabling output 2. This pin has an internal 120kΩ pull-down. 1 = disable outputs, 0 = enable outputs	25	24	24	–
vOE3#	Input	Active low input for enabling output 3. This pin has an internal 120kΩ pull-down. 1 = disable outputs, 0 = enable outputs	28	29	29	–
vOE4#	Input	Active low input for enabling output 4. This pin has an internal 120kΩ pull-down. 1 = disable outputs, 0 = enable outputs	34	35	–	–
vOE5#	Input	Active low input for enabling output 5. This pin has an internal 120kΩ pull-down. 1 = disable outputs, 0 = enable outputs	37	38	–	–

Table 1. Pin Descriptions (Cont.)

Pin Name ^[a] ^[b] ^[c]	Type	Description	08x3 Pin No.	06x3 Pin No.	04x3 Pin No.	02x3 Pin No.
vOE6#	Input	Active low input for enabling output 6. This pin has an internal 120kΩ pull-down. 1 = disable outputs, 0 = enable outputs	43	–	–	–
vOE7#	Input	Active low input for enabling output 7. This pin has an internal 120kΩ pull-down. 1 = disable outputs, 0 = enable outputs	46	–	–	–
vSADR_tri	Latched In	Tri-level latch to select SMBus Address. It has an internal pull-down resistor. See the SMBus Address Selection table.	1	1	32	23

[a] The ‘^’ prefix indicates internal 120kΩ pull-up resistor.

[b] The ‘^v’ prefix indicates internal 120kΩ pull-up and pull-down resistor (biased to VDD/2).

[c] The ‘v’ prefix indicates internal 120kΩ pull-down resistor.

Absolute Maximum Ratings

Stresses above the ratings listed below can cause permanent damage to the 9DBL02x3/9DBL04x3/ 9DBL06x3/9DBL08x3. These ratings, which are standard values for Renesas commercially rated parts, are stress ratings only. Functional operation of the device at these or any other conditions above those indicated in the operational sections of the specifications is not implied. Exposure to absolute maximum rating conditions for extended periods can affect product reliability. Electrical parameters are guaranteed only over the recommended operating temperature range.

Table 2. Absolute Maximum Ratings^[a]

Symbol	Parameter	Conditions	Minimum	Typical	Maximum	Units
V _{DDx}	Supply Voltage ^[b]	Applies to V _{DD} , V _{DDA} and V _{DDIO} .	-0.5		3.9	V
V _{IN}	Input Voltage ^[c]		-0.5		V _{DD} + 0.5	V
V _{IHSMB}	Input High Voltage, SMBus	SMBus clock and data pins.			3.9	V
T _s	Storage Temperature		-65		150	°C
T _j	Junction Temperature				125	°C
ESD prot	Input ESD Protection	Human Body Model.	2000			V

[a] Guaranteed by design and characterization, not 100% tested in production.

[b] Operation under these conditions is neither implied nor guaranteed.

[c] Not to exceed 3.9V.

Electrical Characteristics

Table 3. Additive PCIe Phase Jitter (Fan-out Buffer Mode) [a] [b]

Symbol	Parameter	Conditions	Minimum	Typical	Maximum	Industry Limit	Units
$t_{jphPCIeG1-CC}$	Additive PCIe Phase Jitter (Common Clocked Architecture)	PCIe Gen1 (2.5 GT/s) SSC \leq -0.5%	–	2.6	5.0	86	ps (pk-pk)
$t_{jphPCIeG2-CC}$		PCIe Gen2 Hi Band (5.0 GT/s) SSC \leq -0.5%	–	0.357	0.428	3.1	ps (RMS)
		PCIe Gen2 Lo Band (5.0 GT/s) SSC \leq -0.5%	–	0.023	0.033	3	ps (RMS)
$t_{jphPCIeG3-CC}$		PCIe Gen3 (8.0 GT/s) SSC \leq -0.5%	–	0.091	0.149	1	ps (RMS)
$t_{jphPCIeG4-CC}$		PCIe Gen4 (16.0 GT/s) [c] [d] SSC \leq -0.5%	–	0.092	0.156	0.5	ps (RMS)
$t_{jphPCIeG5-CC}$		PCIe Gen5 (32.0 GT/s) [c] [e] SSC \leq -0.5%	–	0.031	0.059	0.15	ps (RMS)
$t_{jphPCIeG1-SRIS}$	Additive PCIe Phase Jitter (SRIS Architecture) [f]	PCIe Gen1 (2.5 GT/s) SSC \leq -0.3%	–	N/A	N/A	N/A	ps (pk-pk)
$t_{jphPCIeG2-SRIS}$		PCIe Gen2 Band (5.0 GT/s) SSC \leq -0.3%	–	0.455	0.524	N/A	ps (RMS)
$t_{jphPCIeG3-SRIS}$		PCIe Gen3 (8.0 GT/s) SSC \leq -0.3%	–	0.131	0.150	N/A	ps (RMS)
$t_{jphPCIeG4-SRIS}$		PCIe Gen4 (16.0 GT/s) [c] [d] SSC \leq -0.3%	–	0.111	0.128	N/A	ps (RMS)
$t_{jphPCIeG5-SRIS}$		PCIe Gen5 (32.0 GT/s) [c] [e] SSC \leq -0.3%	–	0.040	0.045	N/A	ps (RMS)

Table 4. PCIe Phase Jitter (Zero-Delay Buffer Mode)^{[a] [b]}

Symbol	Parameter	Conditions	Minimum	Typical	Maximum	Industry Limit	Units
$t_{jphPCIeG1-CC}$	PCIe Phase Jitter (Common Clocked Architecture)	PCIe Gen1 (2.5 GT/s), SSC \leq -0.5%, any BW ZDB Mode	–	23	33	86	ps (pk-pk)
$t_{jphPCIeG2-CC}$		PCIe Gen2 Hi Band (5.0 GT/s), SSC \leq -0.5%, any BW ZDB Mode	–	1.4	1.9	3.1	ps (RMS)
$t_{jphPCIeG3-CC}$		PCIe Gen2 Lo Band (5.0 GT/s), SSC \leq -0.5%, any BW ZDB Mode	–	0.5	0.81	3	ps (RMS)
$t_{jphPCIeG4-CC}$		PCIe Gen3 (8.0 GT/s), SSC \leq -0.5%, High BW ZDB Mode	–	0.28	0.53	1	ps (RMS)
$t_{jphPCIeG5-CC}$		PCIe Gen4 (16.0 GT/s) ^{[c] [d]} , SSC \leq -0.5%, High BW ZDB Mode	–	0.26	0.48	0.5	ps (RMS)
$t_{jphPCIeG5-CC}$		PCIe Gen5 (32.0 GT/s) ^{[c] [e]} , SSC \leq -0.5%, High BW ZDB Mode	–	0.07	0.149	0.15	ps (RMS)
$t_{jphPCIeG1-SRIS}$	PCIe Phase Jitter (SRIS Architecture) ^[f]	PCIe Gen1 (2.5 GT/s), SSC \leq -0.5% High BW ZDB Mode	–	N/A	N/A	N/A	ps (pk-pk)
$t_{jphPCIeG2-SRIS}$		PCIe Gen2 (5.0 GT/s), SSC \leq -0.5% High BW ZDB Mode	–	0.99	1.23	N/A	ps (RMS)
$t_{jphPCIeG3-SRIS}$		PCIe Gen3 (8.0 GT/s), SSC \leq -0.5% High BW ZDB Mode	–	0.61	0.69	N/A	ps (RMS)

[a] The Refclk jitter is measured after applying the filter functions found in PCI Express Base Specification 5.0, Revision 1.0. See the [Test Loads](#) section of the data sheet for the exact measurement setup. The total Ref Clk jitter limits for each data rate are listed for convenience. Jitter may be subtracted from the limit using RSS subtraction to determine remaining margin. Guaranteed by design and characterization, not 100% tested in production.

[b] Jitter measurements shall be made with a capture of at least 100,000 clock cycles captured by a real-time oscilloscope (RTO) with a sample rate of 20GS/s or greater. Broadband oscilloscope noise must be minimized in the measurement. The measured PP jitter is used (no extrapolation) for RTO measurements. Alternately, jitter measurements may be used with a Phase Noise Analyzer (PNA) extending (flat) and integrating and folding the frequency content up to an offset from the carrier frequency of at least 200MHz (at 300MHz absolute frequency) below the Nyquist frequency. For PNA measurements for the 2.5GT/s data rate, the RMS jitter is converted to peak to peak jitter using a multiplication factor of 8.83.

[c] SSC spurs from the fundamental and harmonics are removed up to a cutoff frequency of 2MHz taking care to minimize removal of any non-SSC content.

[d] Note that 0.7ps RMS is to be used in channel simulations to account for additional noise in a real system.

[e] Note that 0.25ps RMS is to be used in channel simulations to account for additional noise in a real system.

[f] While the PCI Express Base Specification 5.0, Revision 1.0 provides the filters necessary to calculate SRIS jitter values, it does not provide specification limits, hence the N/A in the Limit column. SRIS values are informative only. In general, a clock operating in an SRIS system must be twice as good as a clock operating in a Common Clock system. For RMS values, twice as good is equivalent to dividing the CC value by $\sqrt{2}$. It is up to the user to divide the clock output budget or the clock input budget by $\sqrt{2}$ to arrive at a target limit.

Table 5. 12kHz to 20MHz Phase Jitter [a] [b]

Symbol	Parameter	Conditions	Minimum	Typical	Maximum	Units
$t_{jph156M12k-20}$	Additive Phase Jitter, Fanout Mode	156.25MHz, 12kHz to 20MHz.	–	363	–	fs (rms)

[a] Guaranteed by design and characterization, not 100% tested in production.

[b] Additive jitter is calculated using Root-Sum-Square (RSS) subtraction.

Table 6. Clock Input Parameters

Symbol	Parameter	Conditions	Minimum	Typical	Maximum	Units
V_{CROSS}	Input Crossover Voltage [a]	Crossover voltage.	150	–	900	mV
V_{SWING}	Input Swing [a]	Differential value.	300	–		mV
dv/dt	Input Slew Rate [a] [b]	Measured differentially.	0.4	–	8	V/ns
I_{IN}	Input Leakage Current	$V_{IN} = V_{DD}$, $V_{IN} = GND$.	-5	–	5	μA
d_{tin}	Input Duty Cycle [a]	Differential measurement.	45	–	55	%
J_{DIFIn}	Input Jitter – Cycle to Cycle [a]		0	–	125	ps

[a] Guaranteed by design and characterization, not 100% tested in production.

[b] Slew rate measured through $\pm 75mV$ window centered around differential zero.

Table 7. Output Duty Cycle, Skew and PLL Characteristics [a]

Symbol	Parameter	Conditions	Minimum	Typical	Maximum	Units
BW	PLL BW [b]	-3dB point in High BW Mode (100MHz).	2	3.3	4	MHz
		-3dB point in Low BW Mode (100MHz).	1	1.5	2	MHz
t_{JPEAK}	PLL Jitter Peaking	Peak Pass band gain (100MHz).		0.8	2	dB
t_{DC}	Duty Cycle [c]	Measured differentially, PLL Mode.	45	50	55	%
t_{DCD}	Duty Cycle Distortion [c] [d]	Measured differentially, Bypass Mode.	-1	0.0	1	%
t_{pdBYP}	Skew, Input to Output [e]	Bypass Mode, $V_T = 50\%$.	2500	3440	4500	ps
t_{pdPLL}		PLL Mode $V_T = 50\%$.	-100	8	100	ps
t_{sk3}	Skew, Output to Output [e]	$V_T = 50\%$.		22	50	ps
$t_{jycyc-cyc}$	Jitter, Cycle to Cycle	PLL Mode.		15	50	ps

[a] Guaranteed by design and characterization, not 100% tested in production.

[b] The Minimum/Typical/Maximum values of each BW setting track each other, i.e., maximum low BW will never occur with minimum high BW.

[c] Measured from differential waveform.

[d] Duty cycle distortion is the difference in duty cycle between the output and the input clock when the device is operated in bypass mode.

[e] All outputs at default slew rate.

Table 8. LP-HCSL (DIF) Output Characteristics

Symbol	Parameter	Conditions	Minimum	Typical	Maximum	Units
dV/dt	Slew Rate [a] [b] [c]	Scope averaging on, fast setting.	2	2.8	4	V/ns
		Scope averaging on, slow setting.	1.2	1.9	3.1	
$\Delta tR/tF$	Rise/Fall Matching [a] [d]	Single-ended measurement.		7	20	%
V_{HIGH}	Voltage High [e]	Statistical measurement on single-ended signal using oscilloscope math function (scope averaging on).	660	777	850	mV
V_{LOW}	Voltage Low [e]		-150	-8	150	
V_{max}	Max Voltage [e]	Measurement on single ended signal using absolute value (scope averaging off).		818	1150	
V_{min}	Min Voltage [e]		-300	-52		
V_{cross_abs}	Crossing Voltage (abs) [a] [f]	Scope averaging off.	250	385	550	
$\Delta-V_{cross}$	Crossing Voltage (var) [a] [g]	Scope averaging off.		15	140	

[a] Guaranteed by design and characterization, not 100% tested in production.

[b] Measured from differential waveform.

[c] Slew rate is measured through the Vswing voltage range centered around differential 0V. This results in a $\pm 150mV$ window around differential 0V.

[d] Matching applies to rising edge rate for Clock and falling edge rate for Clock#. It is measured using a $\pm 75mV$ window centered on the average cross point where Clock rising meets Clock# falling. The median cross point is used to calculate the voltage thresholds the oscilloscope is to use for the edge rate calculations.

[e] At default SMBus settings.

[f] V_{cross} is defined as voltage where Clock = Clock# measured on a component test board and only applies to the differential rising edge (i.e. Clock rising and Clock# falling).

[g] The total variation of all V_{cross} measurements in any particular system. Note that this is a subset of $V_{cross_min/max}$ (V_{cross} absolute) allowed. The intent is to limit V_{cross} induced modulation by setting $\Delta-V_{cross}$ to be smaller than V_{cross} absolute.

Table 9. Current Consumption – 9DBL02xx

Symbol	Parameter	Conditions	Minimum	Typical	Maximum	Units
I_{DDA}	Operating Supply Current	VDDA, PLL Mode at 100MHz.	–	7	10	mA
I_{DDDIG}		VDDDIG, PLL Mode at 100MHz.	–	3.3	5	mA
I_{DDO+R}		VDDO+VDDR, PLL Mode, all outputs at 100MHz.	–	20	25	mA
I_{DDRPD}	Powerdown Current [a]	VDDA, CKPWRGD_PD# = 0.	–	0.6	1.0	mA
$I_{DDDIGPD}$		VDDDIG, CKPWRGD_PD# = 0.	–	3.0	4.3	mA
I_{DDAOPD}		VDDO+VDDR, CKPWRGD_PD# = 0.	–	0.9	1.4	mA

Table 10. Current Consumption – 9DBL04xx

Symbol	Parameter	Conditions	Minimum	Typical	Maximum	Units
I_{DDA}	Operating Supply Current	VDDA, PLL Mode at 100MHz.	–	7	10	mA
I_{DDDIG}		VDDDIG, PLL Mode at 100MHz.	–	3.1	5	mA
I_{DDO+R}		VDDO+VDDR, PLL Mode, all outputs at 100MHz.	–	30	37	mA
I_{DDRPD}	Powerdown Current [a]	VDDA, CKPWRGD_PD# = 0.	–	0.6	1.0	mA
$I_{DDDIGPD}$		VDDDIG, CKPWRGD_PD# = 0.	–	2.9	4.5	mA
I_{DDAOPD}		VDDO+VDDR, CKPWRGD_PD# = 0.	–	0.9	1.3	mA

Table 11. Current Consumption – 9DBL06xx

Symbol	Parameter	Conditions	Minimum	Typical	Maximum	Units
I_{DDA}	Operating Supply Current	VDDA, PLL Mode, at 100MHz.	–	8	10	mA
I_{DD}		VDDx, all outputs active at 100MHz.	–	18	25	mA
I_{DDIO}		VDDIO, all outputs active at 100MHz.	–	26	35	mA
I_{DDAPD}	Powerdown Current [a]	VDDA, CKPWRGD_PD# = 0.	–	0.6	1	mA
I_{DDPD}		VDDx, CKPWRGD_PD# = 0.	–	3.8	6	mA
I_{DDIOPD}		VDDIO, CKPWRGD_PD# = 0.	–	0.05	0.10	mA

Table 12. Current Consumption – 9DBL08xx

Symbol	Parameter	Conditions	Minimum	Typical	Maximum	Units
I_{DDA}	Operating Supply Current	VDDA, PLL Mode, at 100MHz.	–	7	10	mA
I_{DD}		VDDx, all outputs active at 100MHz.	–	20	32	mA
I_{DDIO}		VDDIO, all outputs active at 100MHz.	–	35	45	mA
I_{DDAPD}	Powerdown Current [a]	VDDA, CKPWRGD_PD# = 0.	–	0.6	1	mA
I_{DDPD}		VDDx, CKPWRGD_PD# = 0.	–	3.9	8	mA
I_{DDIOPD}		VDDIO, CKPWRGD_PD# = 0.	–	0.04	0.10	mA

[a] Input clock stopped.

Table 13. Input/Supply/Common Parameters – Recommended Operating Conditions

Symbol	Parameter	Conditions	Minimum	Typical	Maximum	Units
VDDx	Supply Voltage	Supply voltage for core and analog.	3.135	3.3	3.465	V
VDDIO	Output Supply Voltage ^[a]	Supply voltage for Low Power HCSL outputs.	0.95	1.05–3.3	3.465	V
T _{AMB}	Ambient Operating Temperature	Industrial range.	-40	25	85	°C
V _{IH}	Input High Voltage	Single-ended inputs, except SMBus.	0.75 V _{DDx}		V _{DDx} + 0.3	V
V _{IL}	Input Low Voltage		-0.3		0.25 V _{DDx}	V
V _{IHtri}	Input High Voltage	Single-ended tri-level inputs ('_tri' suffix).	0.75 V _{DDx}		V _{DD} + 0.3	V
V _{IMtri}	Input Mid Voltage		0.4 V _{DDx}	0.5 V _{DDx}	0.6 V _{DDx}	V
V _{ILtri}	Input Low Voltage		-0.3		0.25 V _{DDx}	V
I _{IN}	Single-ended Input Current	Inputs without internal pull-up/pull-down resistors V _{IN} = GND, V _{IN} = VDD.	-5		5	μA
I _{INP}		Inputs with internal pull-up resistors, V _{IN} = 0V. Inputs with internal pull-down resistors, V _{IN} = VDD.	-50		50	μA
F _{IN}	Input Frequency	Bypass Mode.	1		200	MHz
		100MHz PLL Mode.	60	100.00	140	MHz
		50MHz PLL Mode.	30	50.00	65	MHz
		125MHz PLL Mode.	75	125.00	175	MHz
L _{pin}	Pin Inductance ^[b]			7	nH	
C _{IN}	Capacitance ^[b]	Logic Inputs, except DIF_IN.	1.5		5	pF
C _{INDIF_IN}		DIF_IN differential clock inputs.	1.5		2.7	pF
C _{OUT}		Output pin capacitance.			6	pF
T _{STAB}	Clk Stabilization ^[c]	From V _{DD} Power-Up and after input clock stabilization or deassertion of PD# to 1st clock.			1	ms
f _{SSCMODIN}	Input SS Modulation Frequency	PCIe applications.	30		33	kHz
		Non-PCIe applications.	0		66	kHz
t _{LATOE#}	OE# Latency ^{[b] [c]}	DIF start after OE# assertion DIF stop after OE# deassertion.	1		3	clocks
t _{DRVPD}	Tdrive_PD# ^{[b] [d]}	DIF output enable after PD# deassertion.			300	μs
t _F	Tfall ^[c]	Fall time of single-ended control inputs.			5	ns
t _R	Trise ^[c]	Rise time of single-ended control inputs.			5	ns

[a] Only present on 9DBL06xx and 9DBL08xx devices.

[b] Guaranteed by design and characterization, not 100% tested in production.

[c] Control inputs must be monotonic from 20% to 80% of input swing.

[d] Time from deassertion until outputs are > 200 mV.

Table 14. SMBus Parameters

Symbol	Parameter	Conditions	Minimum	Typical	Maximum	Units
V _{ILSMB}	SMBus Input Low Voltage	V _{DDSMB} = 3.3V.			0.8	V
V _{IHSMB}	SMBus Input High Voltage	V _{DDSMB} = 3.3V.	2.1		3.6	V
V _{OLSMB}	SMBus Output Low Voltage	At I _{PULLUP} .			0.4	V
I _{PULLUP}	SMBus Sink Current	At V _{OL} .	4			mA
V _{DDSMB}	Nominal Bus Voltage		2.7		3.6	V
t _{RSMB}	SCLK/SDATA Rise Time ^[a]	(Max VIL - 0.15) to (Min VIH + 0.15).			1000	ns
t _{FSMB}	SCLK/SDATA Fall Time ^[a]	(Min VIH + 0.15) to (Max VIL - 0.15).			300	ns
f _{SMB}	SMBus Operating Frequency ^{[b] [c]}	SMBus operating frequency.			500	kHz

[a] Guaranteed by design and characterization, not 100% tested in production.

[b] The device must be powered up for the SMBus to function.

[c] The differential input clock must be running for the SMBus to be active.

Table 15. LOS Parameters

Symbol	Parameter	Conditions	Minimum	Typical	Maximum	Units
t _{LOS}	CLK-IN Loss of Signal Detect Time		–	4.2	6	ms
t _{LOSREL}	CLK-IN Loss of Signal Release Time		–	0.12	0.5	ms

Power Management

Table 16. Power Management

CKPWRGD_PD#	CLK_IN	SMBus OEn bit	OEn# Pin	DIFn	DIFn#	PLL State (ZDB Mode)
0	X	X	X	Low ^[a]	Low ^[a]	Off
1	Running	0	X	Low ^[a]	Low ^[a]	On ^[b]
1	Running	1	0	Running	Running	On ^[b]
1	Running	1	1	Low ^[a]	Low ^[a]	On ^[b]

[a] The output state is set by B11[1:0] (Low/Low default)

[b] If Bypass mode is selected, the PLL will always be off.

ZDB Operating Mode

Table 17. ZDB (PLL) Operating Mode^[a]

HiBW_BypM_LoBW#	Operating Mode	Byte1 [7:6] Readback	Byte1 [4:3] Control
0	Low Bandwidth PLL (ZDB) Mode	00	00
Mid-level (VDD/2)	Bypass Mode (Fanout buffer)	01	01
1	High Bandwidth PLL (ZDB) Mode	11	11

[a] '10' value is reserved.

Test Loads

Figure 5. Test Load for AC/DC Measurements and ZDB Mode PCIe Jitter Measurements

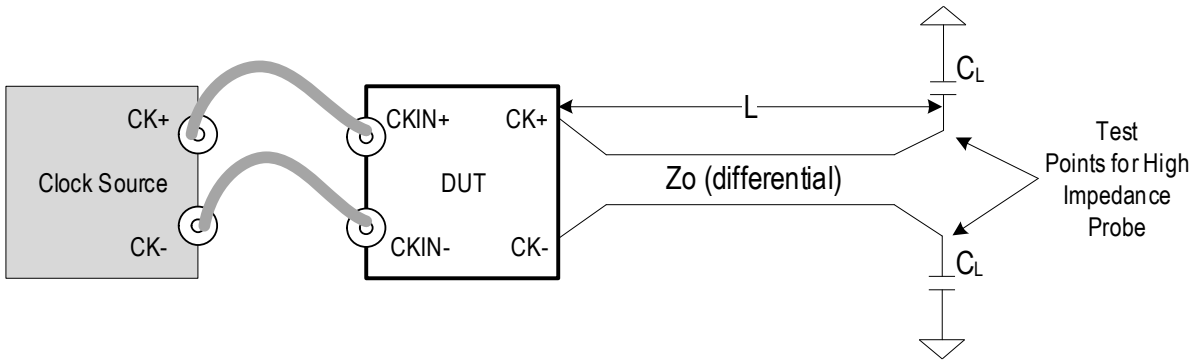

Table 18. Parameters for Measurements Using Test Setup in Figure 5 [a]

Clock Source	Device Under Test (DUT)	Differential Zo (Ω)	L (cm)	CL (pF)	Parameters Measured
SMA100B	9DBLxx5x	85	12.7	2	AC/DC parameters
SMA100B	9DBLxx4x	100	12.7	2	
9FGL08x1C	9DBLxx5x	85	12.7	2	ZDB-mode PCIe Jitter
9FGL08x1C	9DBLxx4x	100	12.7	2	

[a] A DSO is used for all measurements in this table. Equipment noise is removed from all jitter measurements taken with this setup.

Figure 6. Test Loads for Additive Phase Jitter Measurements

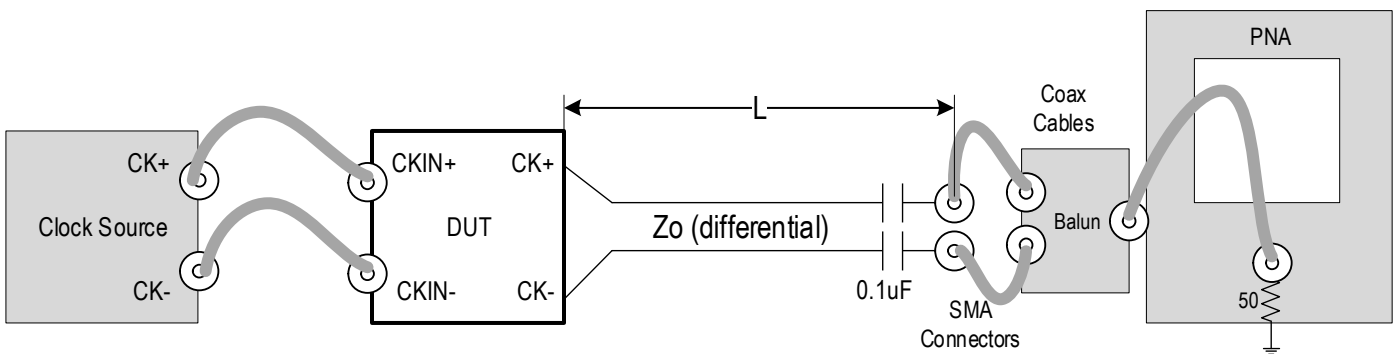

Table 19. Parameters for Measurements Using Test Setup in Figure 6

Clock Source	Device Under Test (DUT)	Differential Zo (Ω)	L (cm)	CL (pF)	Parameters Measured
SMA100B	9DBLxx5x	85	12.7	2	Fan-out Mode Additive PCIe Jitter
SMA100B	9DBLxx4x	100	12.7	2	

General SMBus Serial Interface Information

How to Write

- Controller (host) sends a start bit
- Controller (host) sends the write address
- Renesas clock will **acknowledge**
- Controller (host) sends the beginning byte location = N
- Renesas clock will **acknowledge**
- Controller (host) sends the byte count = X
- Renesas clock will **acknowledge**
- Controller (host) starts sending Byte N through Byte N+X-1
- Renesas clock will **acknowledge** each byte **one at a time**
- Controller (host) sends a stop bit

Index Block Write Operation		
Controller (Host)		Renesas (Slave/Receiver)
T	starT bit	
Slave Address		
WR	WRite	
Beginning Byte = N		ACK
Data Byte Count = X		ACK
Beginning Byte N		ACK
O		O
O		O
O		O
Byte N + X - 1		ACK
P	stoP bit	

How to Read

- Controller (host) will send a start bit
- Controller (host) sends the write address
- Renesas clock will **acknowledge**
- Controller (host) sends the beginning byte location = N
- Renesas clock will **acknowledge**
- Controller (host) will send a separate start bit
- Controller (host) sends the read address
- Renesas clock will **acknowledge**
- Renesas clock will send the data byte count = X
- Renesas clock sends Byte N+X-1
- Renesas clock sends **Byte 0 through Byte X (if X_(H) was written to Byte 8)**
- Controller (host) will need to acknowledge each byte
- Controller (host) will send a not acknowledge bit
- Controller (host) will send a stop bit

Index Block Read Operation		
Controller (Host)		Renesas
T	starT bit	
Slave Address		
WR	WRite	
Beginning Byte = N		ACK
Repeat starT		ACK
Slave Address		
RD	ReaD	
Data Byte Count=X		ACK
Beginning Byte N		O
		O
		O
Byte N + X - 1		ACK
N	Not acknowledge	
P	stoP bit	

Table 20. SMBus Address Selection

State of SADR_tri pin on first high assertion of CKPWRGD_PD#	Address ^[a]
0	1101011x
M	1101100x
1	1101101x

[a] 'x' is the Read/Write bit.

Table 21. Byte 0: Output Enable Control

Byte 0	Bit	7	6	5	4	3	2	1	0
	Function	Output Enable							
	Type	RW	RW	RW	RW	RW	RW	RW	RW
Device	Definition	0 = Output is disabled ^[a] 1 = OE# Pin Controls Output							
9DBL08xx	Name	DIF7oe	DIF6oe	DIF5oe	DIF4oe	DIF3oe	DIF2oe	DIF1oe	DIF0oe
	Default	1	1	1	1	1	1	1	1
9DBL06xx	Name	DIF5oe	DIF4oe	Reserved	DIF3oe	DIF2oe	DIF1oe	Reserved	DIF0oe
	Default	1	1	–	1	1	1	–	1
9DBL04xx	Name	Reserved	DIF3oe	Reserved	DIF2oe	DIF1oe	Reserved	DIF0oe	Reserved
	Default	–	1	–	1	1	–	1	–
9DBL02xx	Name	Reserved			DIF1oe	DIF0oe	Reserved		
	Default	–	–	–	1	1	–	–	–

[a] See Byte11[1:0] for disabled state.

Table 22. Byte 1: PLL Operating Mode and Output Amplitude Control

Byte 1	Bit	7	6	5	4	3	2	1	0
	Function	PLL Mode Readback		Enable software PLL Mode control	Software PLL Mode Control ^[a]		–	Output Amplitude	
	Type	R	R	RW	RW	RW	–	RW	RW
	Definition	See Table 17 (ZDB Mode Operating Table)		0 = B1[7:6] sets PLL Mode 1 = B1[4:3] sets PLL Mode	See Table 17 (ZDB Mode Operating Table)		Reserved	00 = 0.60V 01 = 0.68V 10 = 0.75V 11 = 0.85V	
All Devices	Name	PLLrbk1	PLLrbk0	PLLmdctrl	PLLmd1	PLLmd0	–	Amp1	Amp0
	Default	Latch	Latch	0	0	0	1	1	0

[a] B1[5] must be set to a 1 for these bits to have any effect on the part.

Table 23. Byte 2: Slew Rate Control 0

Byte 2	Bit	7	6	5	4	3	2	1	0
	Function	Slew Rate Selection							
	Type	RW	RW	RW	RW	RW	RW	RW	RW
Device	Definition	0 = Slow Setting, 1 = Fast Setting See electrical characteristics for actual slew rates.							
9DBL08xx	Name	DIF7slew	DIF6slew	DIF5slew	DIF4slew	DIF3slew	DIF2slew	DIF1slew	DIF0slew
	Default	1	1	1	1	1	1	1	1
9DBL06xx	Name	DIF5slew	DIF4slew	Reserved	DIF3slew	DIF2slew	DIF1slew	Reserved	DIF0slew
	Default	1	1	–	1	1	1	–	1
9DBL04xx	Name	Reserved	DIF3slew	Reserved	DIF2slew	DIF1slew	Reserved	DIF0slew	Reserved
	Default	–	1	–	1	1	–	1	–
9DBL02xx	Name	Reserved			DIF1slew	DIF0slew	Reserved		
	Default	–	–	–	1	1	–	–	–

Table 24. Byte 3: ZDB Mode Frequency Select and Feedback Slew Rate Control

Byte 3	Bit	7	6	5	4	3	2	1	0
	Function	–	–	Enable software (SW) selection of ZDB frequency	ZDB Frequency Select ^[a]		–	–	Feedback Slew Rate
	Type	–	–	RW	RW	RW	–	–	RW
	Definition	Reserved		0 = SW frequency select disabled 1 = SW frequency select enabled	00 = 100M 01 = 50M 10 = 125M 11 = Reserved		Reserved		0 = Slow Setting 1 = Fast Setting
All Devices	Name	–	–	FSELn	Fsel1	Fsel0	–	–	FBKslew
	Default	1	1	0	0	0	1	1	1

[a] B3[5] must be set to a 1 for these bits to have any effect on the part.

Byte 4 is Reserved.

Table 25. Byte 5: Revision ID/Vendor ID

Byte 5	Bit	7	6	5	4	3	2	1	0
	Function	Revision ID				VENDOR ID			
	Type	R	R	R	R	R	R	R	R
All Devices	Name	RID3	RID2	RID1	RID0	VID3	VID2	VID1	VID0
	Default	A rev = 0000				0001 = IDT			

Table 26. Byte 6: Device Type/Device ID

Byte 6	Bit	7	6	5	4	3	2	1	0
	Function	Device Type		Device ID					
	Type	R	R	R	R	R	R	R	R
All Devices	Name	DevType 1	DevType0	Dev ID5	Dev ID4	Dev ID3	Dev ID2	Dev ID1	Dev ID0
	Default	01 = DBx ZDB/FOB		9DBL08x3 = 0b011000, 9DBL06x3 = 0b010110 9DBL04x3 = 0b010100, 9DBL02x3 = 0b010010					

Table 27. Byte 7: Byte Count

Byte 7	Bit	7	6	5	4	3	2	1	0
	Function	–	–	–	Byte Count Programming				
	Type	–	–	–	RW	RW	RW	RW	RW
Device	Definition	Reserved			Writing to this register will configure how many bytes will be read back on a block read. Default is = 8 bytes.				
All	Name	–	–	–	BC4	BC3	BC2	BC1	BC0
	Default	0	0	0	0	1	0	0	0

Bytes 8 and 9 are reserved.

Table 28. Byte 10: Power-Down (PD) Restore

Byte 10	Bit	7	6	5	4	3	2	1	0
	Function	–	Restore Default Config in Power Down	–	–	–	–	–	–
	Type	–	RW	–	–	–	–	–	–
	Definition	Reserved	0 = Clear Config. in Power Down 1 = Keep Config. in Power Down	Reserved					
All Devices	Name	–	PD_Restore	–	–	–	–	–	–
	Default	1	1	0	0	0	0	0	0

Table 29. Byte 11: Impedance Control 0 and Stop State

Byte 11	Bit	7	6	5	4	3	2	1	0
	Function	Output Impedance -Feedback		-	-	-	-	DIF/DIF# Disable State	
	Type	RW	RW	-	-	-	-	RW	RW
Device	Definition	00 = 33ohm 01 = 85ohm 10 = 100ohm 11 = Reserved		Reserved				00 = Low/Low 01 = HiZ/HiZ 10 = High/Low 11 = Low/High	
All	Name	FBz1	FBz0	-	-	-	-	Stop1	Stop0
	Default	10 = 9DBLxx4x 01 = 9DBLxx5x		0	0	0	0	0	0

Table 30. Byte 12: Impedance Control 1

Byte 12	Bit	7	6	5	4	3	2	1	0
	Function	Output Impedance							
	Type	RW	RW	RW	RW	RW	RW	RW	RW
Device	Definition	00 = 33ohm, 01 = 85ohm, 10 = 100ohm, 11 = Reserved							
9DBL08xx	Name	DIF3z1	DIF3z0	DIF2z1	DIF2z0	DIF1z1	DIF1z0	DIF0z1	DIF0z0
	Default	9DBL084x = 0b10101010 9DBL085x = 0b01010101							
9DBL06xx	Name	DIF2z1	DIF2z0	DIF1z1	DIF1z0	Reserved		DIF0z1	DIF0z0
	Default	9DBL064x = 0b1010xx10 9DBL065x = 0b0101xx01							
9DBL04xx	Name	DIF1z1	DIF1z0	Reserved		DIF0z1	DIF0z0	Reserved	
	Default	9DBL044x = 0b10xx10xx 9DBL045x = 0b01xx01xx							
9DBL02xx	Name	DIF0z1	DIF0z0	Reserved					
	Default	9DBL024x = 0b10xxxxxx 9DBL025x = 0b01xxxxxx							

Table 31. Byte 13: Impedance Control 2

Byte 13	Bit	7	6	5	4	3	2	1	0
	Function	Output Impedance							
	Type	RW	RW	RW	RW	RW	RW	RW	RW
Device	Definition	00 = 33ohm, 01 = 85ohm, 10 = 100ohm, 11 = Reserved							
9DBL08xx	Name	DIF7z1	DIF7z0	DIF6z1	DIF6z0	DIF5z1	DIF5z0	DIF4z1	DIF4z0
	Default	9DBL084x = 0b10101010 9DBL085x = 0b01010101							
9DBL06xx	Name	DIF5z1	DIF5z0	DIF4z1	DIF4z0	Reserved		DIF3z1	DIF3z0
	Default	9DBL064x = 0b1010xx10 9DBL065x = 0b0101xx01							
9DBL04xx	Name	Reserved		DIF3z1	DIF3z0	Reserved		DIF2z1	DIF2z0
	Default	9DBL044x = 0bxx10xx10 9DBL045x = 0bxx01xx01							
9DBL02xx	Name	Reserved						DIF1z1	DIF1z0
	Default	9DBL024x = 0bxxxxxx10 9DBL025x = 0bxxxxxx01							

Table 32. Byte 14: Pull-up/Pull-down Control 0

Byte 14	Bit	7	6	5	4	3	2	1	0
	Function	Pull-up (PuP)/Pull-down (Pdwn) control							
	Type	RW	RW	RW	RW	RW	RW	RW	RW
Device	Definition	00 = None, 01 = Pdwn, 10 = Pup, 11 = Pup+Pdwn							
9DBL08xx	Name	OE3pu/pd1	OE3pu/pd0	OE2pu/pd1	OE2pu/pd0	OE1pu/pd1	OE1pu/pd0	OE0pu/pd1	OE0pu/pd0
	Default	0	1	0	1	0	1	0	1
9DBL06xx	Name	OE2pu/pd1	OE2pu/pd0	OE1pu/pd1	OE1pu/pd0	Reserved		OE0pu/pd1	OE0pu/pd0
	Default	0	1	0	1	-	-	0	1
9DBL04xx	Name	OE1pu/pd1	OE1pu/pd0	Reserved		OE0pu/pd1	OE0pu/pd0	Reserved	
	Default	0	1	-	-	0	1	-	-
9DBL02xx	Name	OE0pu/pd1	OE0pu/pd0	Reserved					
	Default	0	1	-	-	-	-	-	-

Table 33. Byte 15: Pull-up/Pull-down Control 1

Byte 15	Bit	7	6	5	4	3	2	1	0
	Function	Pull-up (PuP)/Pull-down (Pdwn) control							
	Type	RW	RW	RW	RW	RW	RW	RW	RW
Device	Definition	00 = None, 01 = Pdwn, 10 = Pup, 11 = Pup+Pdwn							
9DBL08xx	Name	OE7pu/pd1	OE7pu/pd0	OE6pu/pd1	OE6pu/pd0	OE5pu/pd1	OE5pu/pd0	OE4pu/pd1	OE4pu/pd0
	Default	0	1	0	1	0	1	0	1
9DBL06xx	Name	OE5pu/pd1	OE5pu/pd0	OE4pu/pd1	OE4pu/pd0	Reserved		OE3pu/pd1	OE3pu/pd0
	Default	0	1	0	1	-	-	0	1
9DBL04xx	Name	Reserved		OE3pu/pd1	OE3pu/pd0	Reserved		OE2pu/pd1	OE2pu/pd0
	Default	-	-	0	1	-	-	0	1
9DBL02xx	Name	Reserved						OE1pu/pd1	OE1pu/pd0
	Default	-	-	-	-	-	-	0	1

Table 34. Byte 16: Pull-up_Pull-down Control 2

Byte 16	Bit	7	6	5	4	3	2	1	0	
	Function	-	-	-	-	-	-	Pull-up(PuP)/Pull-down (Pdwn) control		
	Type	-	-	-	-	-	-	RW	RW	
Device	Definition	Reserved						00 = None, 01 = Pdwn, 10 = Pup, 11 = Pup+Pdwn		
All	Name	-	-	-	-	-	-	CKPWRGD_PD_ pu/pd1	CKPWRGD_PD_ pu/pd0	
	Default	0	0	0	0	0	0	1	0	

Byte 17 is Reserved.

Table 35. Byte 18: Polarity Control 0

Byte 18	Bit	7	6	5	4	3	2	1	0
	Function	OE pin polarity							
	Type	RW	RW	RW	RW	RW	RW	RW	RW
Device	Definition	0 = Output enabled when OE pin is Low 1 = Output enabled when OE pin is High							
9DBL08xx	Name	OE7pol	OE6pol	OE5pol	OE4pol	OE3pol	OE2pol	OE1pol	OE0pol
	Default	0	0	0	0	0	0	0	0
9DBL06xx	Name	OE5pol	OE4pol	Reserved	OE3pol	OE2pol	OE1pol	Reserved	OE0pol
	Default	0	0	0	0	0	0	0	0
9DBL04xx	Name	Reserved	OE3pol	Reserved	OE2pol	OE1pol	Reserved	OE0pol	Reserved
	Default	0	0	0	0	0	0	0	0
9DBL02xx	Name	Reserved			OE1pol	OE0pol	Reserved		
	Default	0	0	0	0	0	0	0	0

Table 36. Byte 19: Polarity Control 1

Byte 19	Bit	7	6	5	4	3	2	1	0
	Function	–	–	–	–	–	–	LOS pin polarity	CKPWRGD_PD pin polarity
	Type	–	–	–	–	–	–	RW	RW
	Definition	Reserved						0 = Low when input clock absent 1 = High when input clock absent	0 = Power Down when Low 1 = Power Down when High
All Devices	Name	–	–	–	–	–	–	LOS_pol	CKPWRGD_Pdpol
	Default	0	0	0	0	0	0	1	0

Package Outline Drawings

The package outline drawings are appended at the end of this document and are accessible from the link below. The package information is the most current data available.

9DBL02x3:

www.idt.com/us/en/document/psc/24-vfqfnp-package-outline-drawing-40-x-40-x-090-mm-body050mm-pitchepad-260-x-260-mm-nlg24p3

9DBL04x3:

www.idt.com/us/en/document/psc/32-vfqfnp-package-outline-drawing-50-x-50-x-090-mm-body-epad-315-x-315-mm-nlg32p1

9DBL06x3:

www.idt.com/document/psc/ndndg40-package-outline-50-x-50-mm-bodyepad-350mm-sq-040-mm-pitch-qfn

9DBL08x3:

www.idt.com/us/en/document/psc/48-vfqfnp-package-outline-drawing-60-x-60-x-090-mm-body-epad-41-x-41-mm-040mm-pitch-ndg48p1

Thermal Characteristics

Table 37. Thermal Characteristics [a]

Symbol	Conditions	Package	Typical Values	Units
θ_{JC}	Junction to case.	NDG48	33	°C/W
θ_{Jb}	Junction to base.		2	°C/W
θ_{JA0}	Junction to air, still air.		37	°C/W
θ_{JA1}	Junction to air, 1 m/s air flow.		30	°C/W
θ_{JA3}	Junction to air, 3 m/s air flow.		27	°C/W
θ_{JA5}	Junction to air, 5 m/s air flow.		26	°C/W
θ_{JC}	Junction to case.	NDG40 NLG32	42	°C/W
θ_{Jb}	Junction to base.		2	°C/W
θ_{JA0}	Junction to air, still air.		39	°C/W
θ_{JA1}	Junction to air, 1 m/s air flow.		33	°C/W
θ_{JA3}	Junction to air, 3 m/s air flow.		28	°C/W
θ_{JA5}	Junction to air, 5 m/s air flow.		27	°C/W
θ_{JC}	Junction to case.	NLG24	60	°C/W
θ_{Jb}	Junction to base.		5.4	°C/W
θ_{JA0}	Junction to air, still air.		50	°C/W
θ_{JA1}	Junction to air, 1 m/s air flow.		43	°C/W
θ_{JA3}	Junction to air, 3 m/s air flow.		39	°C/W
θ_{JA5}	Junction to air, 5 m/s air flow.		38	°C/W

[a] epad soldered to ground

Marking Diagrams

9DBL02x3

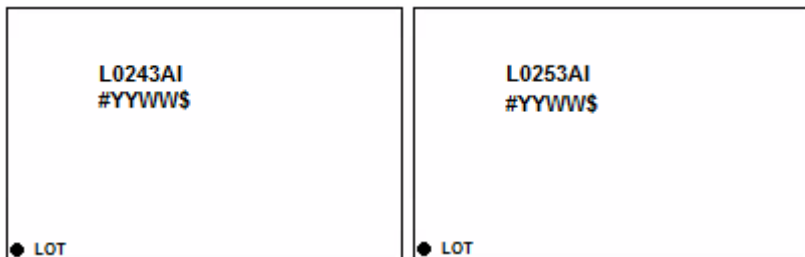

- Line 1: truncated part number.
 - “I” denotes industrial temperature range device.
- Line 2:
 - “#” is the stepping number.
 - “YYWW” is the last two digits of the year and week that the part was assembled.
 - “\$” is the mark code.
- “LOT” is the lot sequence number.

9DBL04x3

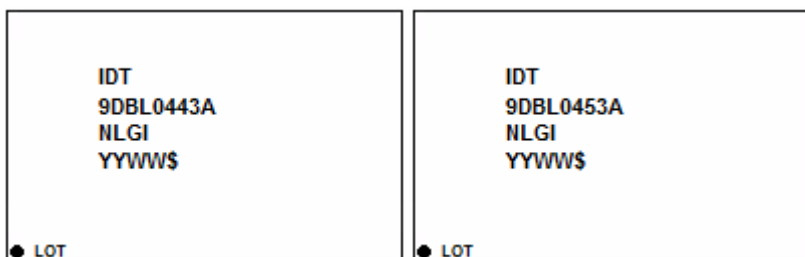

- Lines 2 and 3: part number.
 - “I” denotes industrial temperature range.
- Line 4:
 - “YYWW” is the last two digits of the year and week the part was assembled.
 - “\$” is the mark code.
- “LOT” is the lot sequence number.

9DBL06x3

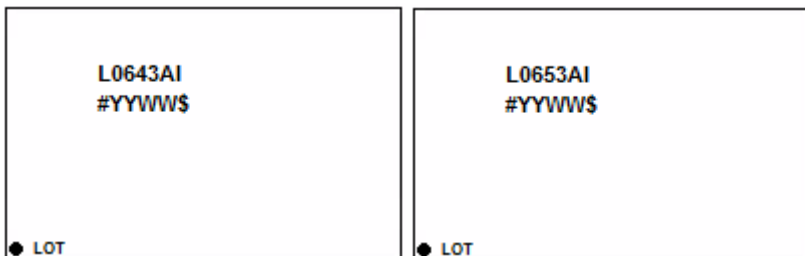

- Line 1: truncated part number.
 - “I” denotes industrial temperature range device.
- Line 2:
 - “#” is the stepping number.
 - “YYWW” is the last two digits of the year and week that the part was assembled.
 - “\$” is the mark code.
- “LOT” is the lot sequence number.

9DBL08x3

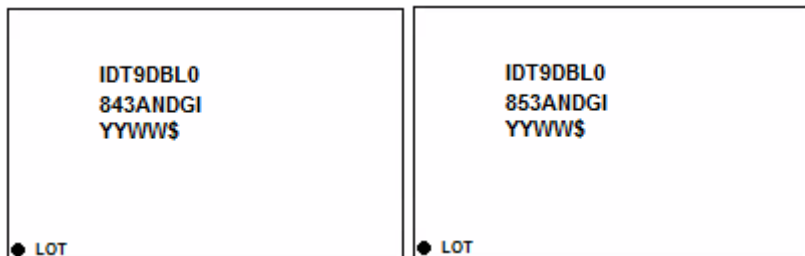

- Lines 1 and 2: part number.
 - “I” denotes industrial temperature range.
- Line 3:
 - “YYWW” is the last two digits of the year and week the part was assembled.
 - “\$” is the mark code.
- “LOT” is the lot sequence number.

Ordering Information

Table 38. Ordering Information [a] [b] [c] [d]

Output Impedance (Ω)	Number of Clock Outputs	Package	Orderable Part Number	Shipping Package
85	2	4 × 4 × 0.9 mm, 0.50mm pitch 24-VFQFPN	9DBL0253ANLGI	Trays
			9DBL0253ANLGI8	Tape and Reel
	4	5 × 5 × 0.9 mm, 0.50mm pitch 32-VFQFPN	9DBL0453ANLGI	Trays
			9DBL0453ANLGI8	Tape and Reel
	6	5 × 5 × 0.9 mm, 0.40mm pitch 40-VFQFPN	9DBL0653ANDGI	Trays
			9DBL0653ANDGI8	Tape and Reel
8	6 × 6 × 0.9 mm, 0.40mm pitch 48-VFQFPN	9DBL0853ANDGI	Trays	
		9DBL0853ANDGI8	Tape and Reel	
100	2	4 × 4 × 0.9 mm, 0.50mm pitch 24-VFQFPN	9DBL0243ANLGI	Trays
			9DBL0243ANLGI8	Tape and Reel
	4	5 × 5 × 0.9 mm, 0.50mm pitch 32-VFQFPN	9DBL0443ANLGI	Trays
			9DBL0443ANLGI8	Tape and Reel
	6	5 × 5 × 0.9 mm, 0.40mm pitch 40-VFQFPN	9DBL0643ANDGI	Trays
			9DBL0643ANDGI8	Tape and Reel
8	6 × 6 × 0.9 mm, 0.40mm pitch 48-VFQFPN	9DBL0843ANDGI	Trays	
		9DBL0843ANDGI8	Tape and Reel	

[a] "A" is the device revision designator (will not correlate with the datasheet revision).

[b] "G" denotes Pb-free configuration, RoHS compliant.

[c] "I" indicates that all devices are specified over the -40°C to +85°C (industrial) temperature range.

[d] "8" = Tape and Reel, Pin 1 Orientation: EIA-481C (see [Table 39](#) for more details).

Table 39. Pin 1 Orientation in Tape and Reel Packaging

Part Number Suffix	Pin 1 Orientation	Illustration
8	Quadrant 1 (EIA-481-C)	

Revision History

Table 40. Revision History

Revision Date	Description of Change
January 24, 2021	<ul style="list-style-type: none"> ▪ Added missing cross reference to Table 17 (ZDB Operating Mode) into Table 22 (Byte 1 description). ▪ Added minor updates to Table 17 for clarity and consistency.
August 13, 2020	<p>Changed the shipping package for the 9DBL0243A and 0253A from “Cut Tape” to “Trays” in the Ordering Information table.</p>
July 22, 2020	<ul style="list-style-type: none"> ▪ Merged 9DBL02x2, 9DBL04x2, 9DBL06x1 and 9DBL08x1 into single document. ▪ Updated PCIe jitter tables to show PCIe Gen5. ▪ Updated Test Loads figures to indicate PCIe Jitter Test setup. ▪ Updated package outline drawings link for the 9DBL08x3 devices to NDG48P1. ▪ Updated ordering information.
March 15, 2020	<p>Last update of 9DBL0243/253 Datasheet.</p>
February 1, 2017	<p>Last update of 9DBL0443/0453 Datasheet.</p>
February 1, 2017	<p>Last update of 9DBL0643/0653 Datasheet.</p>
February 1, 2017	<p>Last update of 9DBL0843/0853 Datasheet.</p>

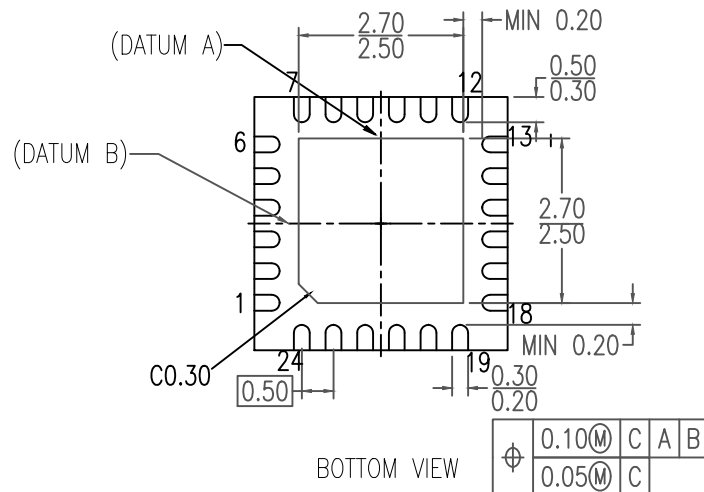
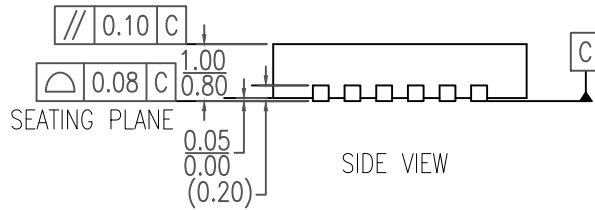
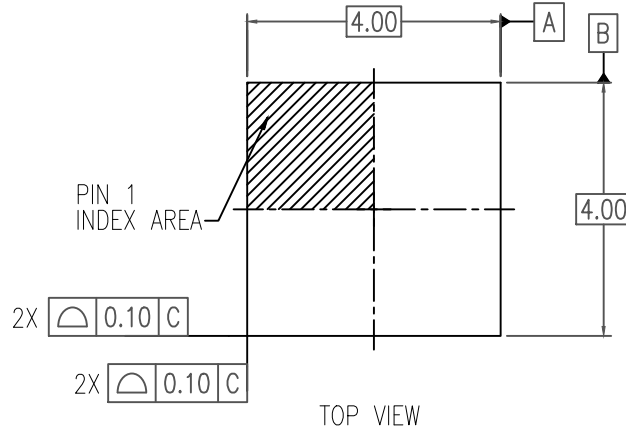

NOTES:

1. DIMENSIONING AND TOLERANCING CONFORME TO ASME Y14.5M-1994.
2. ALL DIMENSIONS ARE IN MILLIMETERS.

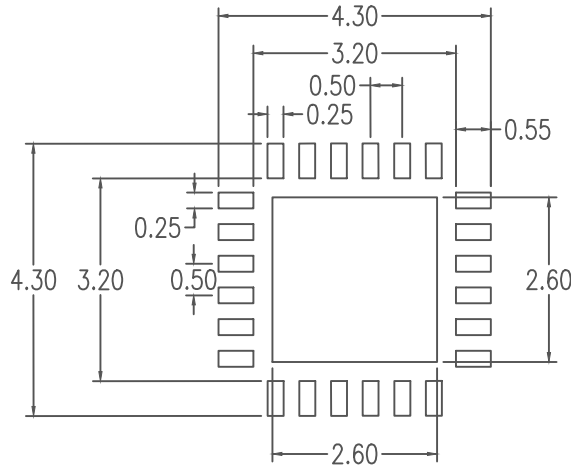

RECOMMENDED LAND PATTERN DIMENSION

NOTES:

1. ALL DIMENSIONS ARE IN MM. ANGLES IN DEGREES.
2. TOP DOWN VIEW, AS VIEWED ON PCB.
3. LAND PATTERN RECOMMENDATION PER IPC-7351B GENERIC REQUIREMENT FOR SURFACE MOUNT DESIGN AND LAND PATTERN.

Package Revision History		
Date Created	Rev No.	Description
June 15, 2016	Rev 01	Correct Title Block
Oct 3, 2018	Rev 02	New Format, Recalculate Land Pattern Change QFN to VFQFPN

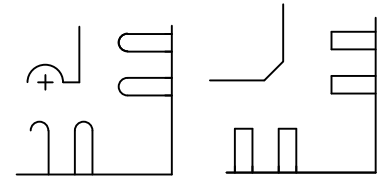
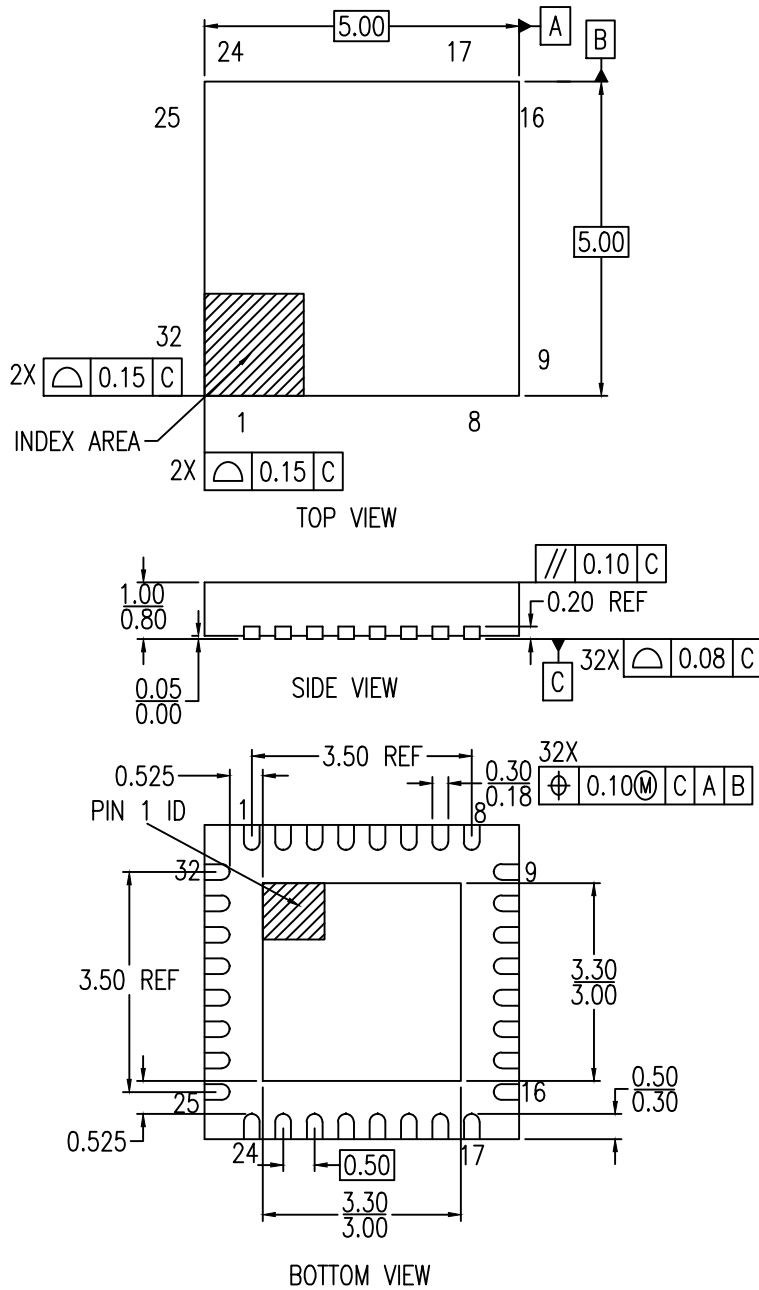

PIN #1 ID OPTION

NOTE:

1. ALL DIMENSION ARE IN MM. ANGLES IN DEGREES.
2. COPLANARITY APPLIE TO THE EXPOSED PAD AS WELL AS THE TERMINALS.
COPLANARITY SHALL NOT EXCEED 0.08 MM.
3. WARPAGE SHALL NOT EXCEED 0.10 MM.
4. PIN LOCATION IS UNIDENTIFIED BY EITHER CHAMFER OR NOTCH.

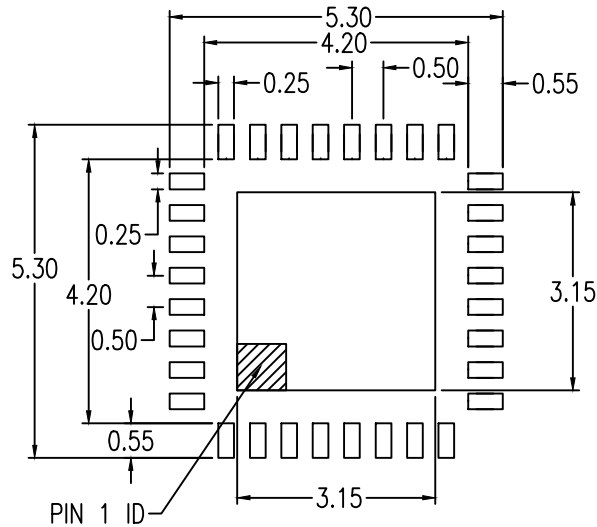

RECOMMENDED LAND PATTERN DIMENSION

1. ALL DIMENSIONS ARE IN MM. ANGLES IN DEGREES.
2. TOP DOWN VIEW, AS VIEWED ON PCB.
3. LAND PATTERN RECOMMENDATION PER IPC-7351B GENERIC REQUIREMENT FOR SURFACE MOUNT DESIGN AND LAND PATTERN.

Package Revision History		
Date Created	Rev No.	Description
April 12, 2018	Rev 02	New Format
Feb 8, 2016	Rev 01	Added "k: Value

REVISIONS			
REV	DESCRIPTION	DATE	APPROVED
00	INITIAL RELEASE	5/17/16	JH

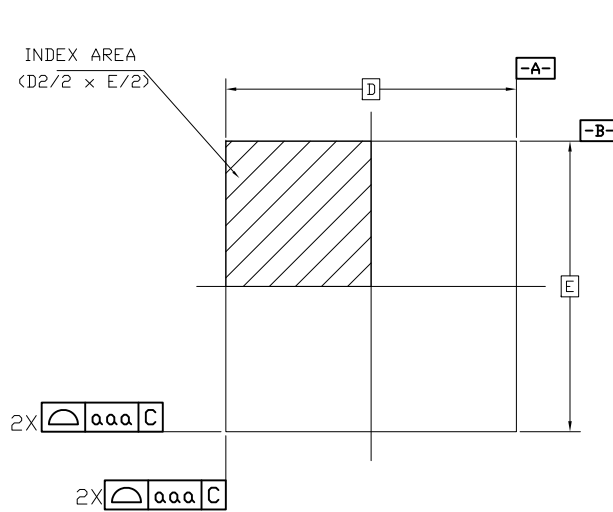

TOP VIEW

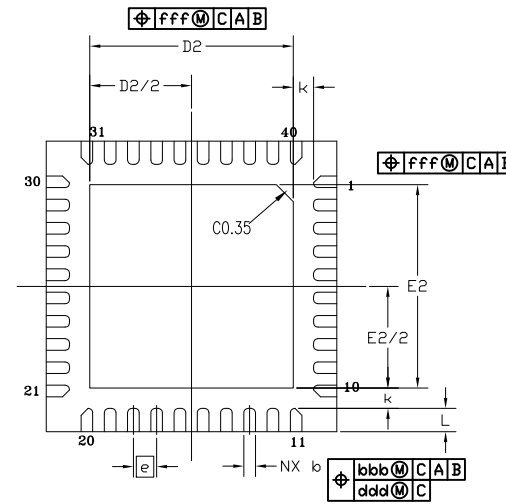

BOTTOM VIEW

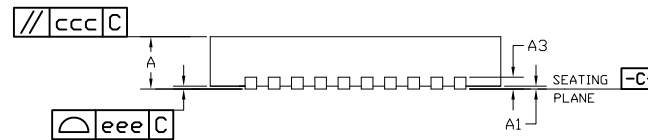

SIDE VIEW

SYMBOL	DIMENSION		
	MIN	NOM	MAX
b	0.15	0.20	0.25
D	5.00 BSC		
E	5.00 BSC		
D2	3.40	3.50	3.60
E2	3.40	3.50	3.60
L	0.30	0.40	0.50
e	0.40 BSC		
N	40		
ND	10 (note 3)		
NE	10 (note 3)		
A	0.80	0.90	1.00
A1	0.00	0.02	0.05
A3	0.2 REF		
k	0.35 REF		
aaa	0.10		
bbb	0.07		
ccc	0.10		
ddd	0.05		
eee	0.08		
fff	0.10		

NOTES:

1. ALL DIMENSIONING AND TOLERANCING CONFORM TO ANSI Y14.5M-1982
2. ALL DIMENSIONS ARE IN MILLIMETERS.
3. ND AND NE REFER TO THE NUMBER OF TERMINALS ON EACH D AND E SIDE RESPECTIVELY.

TOLERANCES UNLESS SPECIFIED		 www.IDT.com	6024 SILVER CREEK VALLEY ROAD. SAN JOSE, CA 95138 PHONE: (408) 284-8200 FAX: (408) 284-3572
DECIMAL	ANGULAR		
X±.1	±1°	TITLE/NDG40 PACKAGE OUTLINE	
XX±.05		5.0 x 5.0 mm BODY, EPAD 3.50mm SQ.	
XXX±.030		0.40 mm PITCH QFN	
APPROVALS	DATE	SIZE	DRAWING No.
DRAWN <i>ma</i>	05/31/10	C	PSC-4292-02
CHECKED			REV 00
DO NOT SCALE DRAWING			SHEET 1 OF 2

REVISIONS			
REV	DESCRIPTION	DATE	APPROVED
00	INITIAL RELEASE	5/17/16	JH

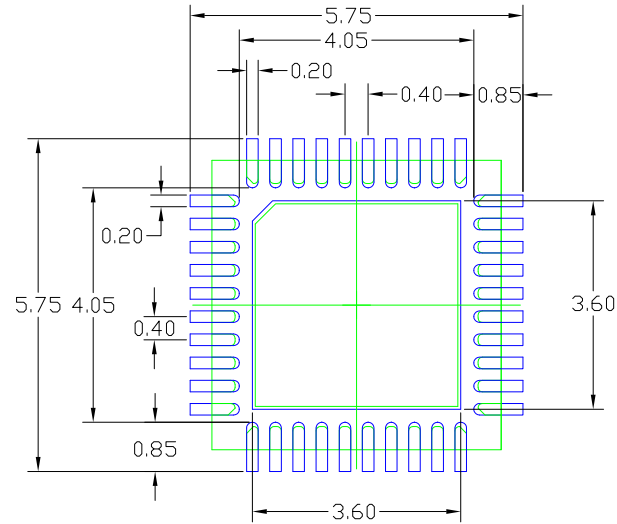

RECOMMENDED LAND PATTERN

NOTES:

1. ALL DIMENSIONS ARE IN mm. ANGLES IN DEGREES.
2. TOP DOWN VIEW AS VIEWED ON PCB.
3. COMPONENT OUTLINE SHOWS FOR REFERENCE IN GREEN.
4. LAND PATTERN IN BLUE. NSMD PATTERN ASSUMED.
5. LAND PATTERN RECOMMENDATION PER IPC-7351B GENERIC REQUIREMENT FOR SURFACE MOUNT DESIGN AND LAND PATTERN.

TOLERANCES UNLESS SPECIFIED		 www.IDT.com	6024 SILVER CREEK VALLEY ROAD, SAN JOSE, CA 95138 PHONE: (408) 284-8200 FAX: (408) 284-3572	
DECIMAL	ANGULAR			
X±.1	±1°			
XX±.05				
XXX±.030				
APPROVALS	DATE	TITLE/NDG40 PACKAGE OUTLINE		
DRAWN <i>mar</i>	05/31/10	5.0 x 5.0 mm BODY, EPAD 3.50mm SQ.		
CHECKED		0.40 mm PITCH QFN		
		SIZE	DRAWING No.	REV
		C	PSC-4292-02	00
DO NOT SCALE DRAWING				SHEET 2 OF 2

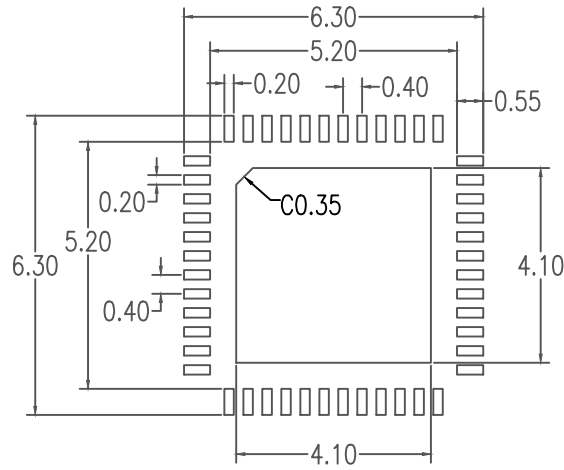

RECOMMENDED LAND PATTERN DIMENSION

NOTES:

1. ALL DIMENSION ARE IN MM. ANGLES IN DEGREES.
2. TOP DOWN VIEW. AS VIEWED ON PCB.
3. LAND PATTERN RECOMMENDATION PER IPC-7351B GENERIC REQUIREMENT FOR SURFACE MOUNT DESIGN AND LAND PATTERN.

Package Revision History		
Date Created	Rev No.	Description
Aug16, 2018	Rev 01	New Format Change QFN to VFQFPN, Recalculate Land Pattern
May 6, 2016	Rev 00	Add Chamfer