

### Description

The 9DBV0231 is a member of Renesas' 1.8V Very-Low-Power (VLP) PCIe family. The device has 2 output enables for clock management.

### Recommended Application

1.8V PCIe Gen1–5 Zero-Delay/Fan-out Buffer (ZDB/FOB)

### Output Features

- Two 1–200MHz Low-Power (LP) HCSL DIF pairs

### Key Specifications

- DIF cycle-to-cycle jitter < 50ps
- DIF output-to-output skew < 50ps
- PCIe Gen5 CC additive phase jitter < 40fs RMS
- 12kHz–20MHz additive phase jitter = 156fs RMS at 156.25MHz (typical)

### Features/Benefits

- LP-HCSL outputs; save 4 resistors compared to standard HCSL outputs
- 35mW typical power consumption in PLL mode; reduced thermal concerns
- Spread Spectrum (SS) compatible; allows use of SS for EMI reduction
- OE# pins; support DIF power management
- HCSL compatible differential input; can be driven by common clock sources
- SMBus-selectable features; optimize signal integrity to application
  - Slew rate for each output
  - Differential output amplitude
- Pin/software selectable PLL bandwidth and PLL Bypass; minimize phase jitter for each application
- Outputs blocked until PLL is locked; clean system start-up
- Device contains default configuration; SMBus interface not required for device control
- 3.3V tolerant SMBus interface works with legacy controllers
- Space saving 4 × 4mm 24-VFQFPN; minimal board space

### Block Diagram

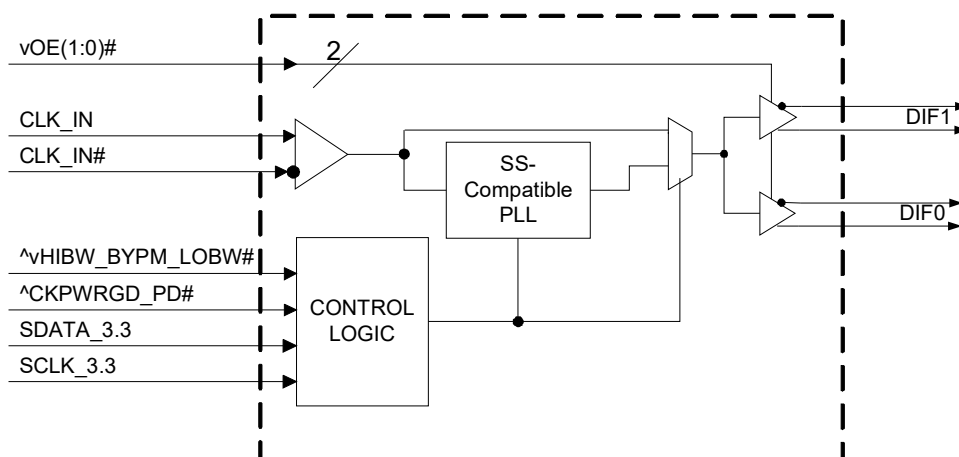

## Pin Configuration

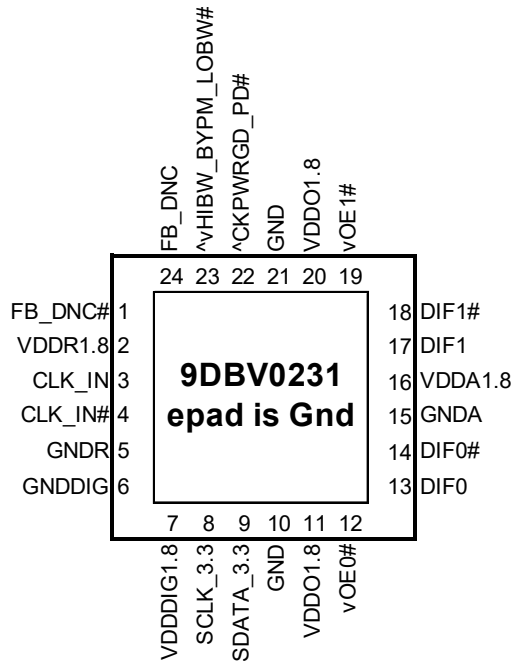

### 24-pin VFQFPN, 4x4 mm, 0.5mm pitch

- ^ prefix indicates internal 120KOhm pull up resistor
- ^v prefix indicates internal 120KOhm pull up AND pull down resistor (biased to VDD/2)
- v prefix indicates internal 120KOhm pull down resistor

## Power Management Table

CKPWRGD_PD#	CLK_IN	SMBus OEx bit	OEx# Pin	DIFx		PLL
				True O/P	Comp. O/P	
0	X	X	X	Low	Low	Off
1	Running	0	X	Low	Low	On <sup>1</sup>
1	Running	1	0	Running	Running	On <sup>1</sup>
1	Running	1	1	Low	Low	On <sup>1</sup>

1. If Bypass mode is selected, the PLL will be off, and outputs will be running.

## SMBus Address Table

Address	+ Read/Write bit
1101101	x

## Power Connections

Pin Number		Description
VDD	GND	
2	5	Input receiver analog
7	6	Digital Power
11,20	10,21	DIF outputs
16	15	PLL Analog

## Frequency Select Table

FSEL Byte3 [4:3]	CLK_IN (MHz)	DIFx (MHz)
00 (Default)	100.00	CLK IN
01	50.00	CLK IN
10	125.00	CLK IN
11	Reserved	Reserved

## PLL Operating Mode

HiBW_BypM_LoBW#	MODE	Byte1 [7:6] Readback	Byte1 [4:3] Control
0	PLL Lo BW	00	00
M	Bypass	01	01
1	PLL Hi BW	11	11

## Pin Descriptions

Pin#	Pin Name	Type	Description
1	FB_DNC#	DNC	Complement clock of differential feedback. The feedback output and feedback input are connected internally on this pin. Do not connect anything to this pin.
2	VDDR1.8	PWR	1.8V power for differential input clock (receiver). This VDD should be treated as an Analog power rail and filtered appropriately.
3	CLK_IN	IN	True Input for differential reference clock.
4	CLK_IN#	IN	Complementary Input for differential reference clock.
5	GNDR	GND	Analog Ground pin for the differential input (receiver)
6	GNDDIG	GND	Ground pin for digital circuitry
7	VDDDIG1.8	PWR	1.8V digital power (dirty power)
8	SCLK_3.3	IN	Clock pin of SMBus circuitry, 3.3V tolerant.
9	SDATA_3.3	I/O	Data pin for SMBus circuitry, 3.3V tolerant.
10	GND	GND	Ground pin.
11	VDDO1.8	PWR	Power supply for outputs, nominally 1.8V.
12	vOE0#	IN	Active low input for enabling DIF pair 0. This pin has an internal pull-down. 1 =disable outputs, 0 = enable outputs
13	DIF0	OUT	Differential true clock output
14	DIF0#	OUT	Differential Complementary clock output
15	GNDA	GND	Ground pin for the PLL core.
16	VDDA1.8	PWR	1.8V power for the PLL core.
17	DIF1	OUT	Differential true clock output
18	DIF1#	OUT	Differential Complementary clock output
19	vOE1#	IN	Active low input for enabling DIF pair 1. This pin has an internal pull-down. 1 =disable outputs, 0 = enable outputs
20	VDDO1.8	PWR	Power supply for outputs, nominally 1.8V.
21	GND	GND	Ground pin.
22	^CKPWRGD_PD#	IN	Input notifies device to sample latched inputs and start up on first high assertion. Low enters Power Down Mode, subsequent high assertions exit Power Down Mode. This pin has internal pull-up resistor.
23	^vHIBW_BYPM_LOBW#	LATCHED IN	Trilevel input to select High BW, Bypass or Low BW mode. See PLL Operating Mode Table for Details.
24	FB_DNC	DNC	True clock of differential feedback. The feedback output and feedback input are connected internally on this pin. Do not connect anything to this pin.
25	ePad	GND	Connect epad to ground.

NOTE: DNC indicates Do Not Connect anything to this pin.

## Test Loads

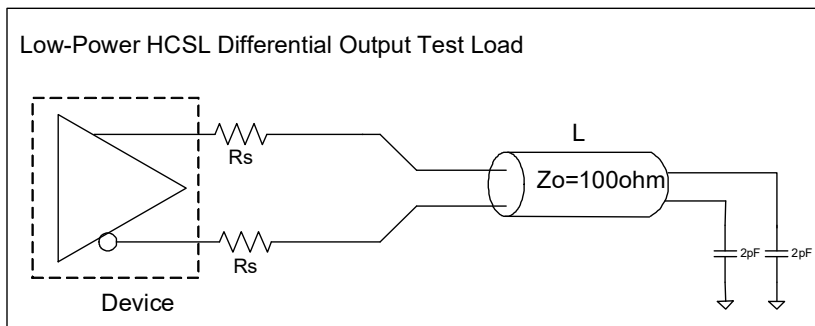

L = 5 inches

### Differential Output Terminations

Rs	Zo	Units
33	100	Ohms
27	85	

## Alternate Terminations

The 9DBV family can easily drive LVPECL, LVDS, and CML logic. See [“AN-891 Driving LVPECL, LVDS, and CML Logic with “Universal” Low-Power HCSL Outputs”](#) for details.

## Absolute Maximum Ratings

Stresses above the ratings listed below can cause permanent damage to the 9DBV0231. These ratings, which are standard values for Renesas commercially rated parts, are stress ratings only. Functional operation of the device at these or any other conditions above those indicated in the operational sections of the specifications is not implied. Exposure to absolute maximum rating conditions for extended periods can affect product reliability. Electrical parameters are guaranteed only over the recommended operating temperature range.

PARAMETER	SYMBOL	CONDITIONS	MIN	TYP	MAX	UNITS	NOTES
1.8V Supply Voltage	VDDxx	Applies to all VDD pins	-0.5		2.5	V	1,2
Input Voltage	V <sub>IN</sub>		-0.5		V <sub>DD</sub> +0.5V	V	1, 3
Input High Voltage, SMBus	V <sub>IHSMB</sub>	SMBus clock and data pins			3.6V	V	1
Storage Temperature	T <sub>s</sub>		-65		150	°C	1
Junction Temperature	T <sub>j</sub>				125	°C	1
Input ESD protection	ESD prot	Human Body Model	2000			V	1

<sup>1</sup>Guaranteed by design and characterization, not 100% tested in production.

<sup>2</sup>Operation under these conditions is neither implied nor guaranteed.

<sup>3</sup>Not to exceed 2.5V.

## Electrical Characteristics–Clock Input Parameters

TA = T<sub>AMB</sub>, Supply Voltages per normal operation conditions, See Test Loads for Loading Conditions

PARAMETER	SYMBOL	CONDITIONS	MIN	TYP	MAX	UNITS	NOTES
Input Common Mode Voltage - DIF_IN	V <sub>COM</sub>	Common Mode Input Voltage	150		1000	mV	1
Input Swing - DIF_IN	V <sub>SWING</sub>	Differential value	300		1450	mV	1
Input Slew Rate - DIF_IN	dv/dt	Measured differentially	0.4		8	V/ns	1,2
Input Leakage Current	I <sub>IN</sub>	V <sub>IN</sub> = V <sub>DD</sub> , V <sub>IN</sub> = GND	-5		5	uA	
Input Duty Cycle	d <sub>tin</sub>	Measurement from differential waveform	45		55	%	1
Input Jitter - Cycle to Cycle	J <sub>DIFIn</sub>	Differential Measurement	0		125	ps	1

<sup>1</sup>Guaranteed by design and characterization, not 100% tested in production.

<sup>2</sup>Slew rate measured through +/-75mV window centered around differential zero.

## Electrical Characteristics–Input/Supply/Common Parameters–Normal Operating Conditions

$T_A = T_{AMB}$ , Supply Voltages per normal operation conditions, See Test Loads for Loading Conditions

PARAMETER	SYMBOL	CONDITIONS	MIN	TYP	MAX	UNITS	NOTES
Supply Voltage	VDDx	Supply voltage for core and analog	1.7	1.8	1.9	V	
Ambient Operating Temperature	$T_{AMB}$	Commercial range	0	25	70	°C	
		Industrial range	-40	25	85	°C	
Input High Voltage	$V_{IH}$	Single-ended inputs, except SMBus	$0.75 V_{DD}$		$V_{DD} + 0.3$	V	
Input Mid Voltage	$V_{IM}$	Single-ended tri-level inputs ('_tri' suffix)	$0.4 V_{DD}$		$0.6 V_{DD}$	V	
Input Low Voltage	$V_{IL}$	Single-ended inputs, except SMBus	-0.3		$0.25 V_{DD}$	V	
Input Current	$I_{IN}$	Single-ended inputs, $V_{IN} = GND$ , $V_{IN} = V_{DD}$	-5		5	uA	
	$I_{INP}$	Single-ended inputs $V_{IN} = 0 V$ ; Inputs with internal pull-up resistors $V_{IN} = V_{DD}$ ; Inputs with internal pull-down resistors	-200		200	uA	
Input Frequency	$F_{ibyp}$	Bypass mode	1		200	MHz	2
	$F_{ipll}$	100MHz PLL mode	50	100.00	140	MHz	2
	$F_{ipll}$	125MHz PLL mode	62.5	125.00	175	MHz	2
	$F_{ipll}$	50MHz PLL mode	25	50.00	65	MHz	2
Pin Inductance	$L_{pin}$				7	nH	1
Capacitance	$C_{IN}$	Logic Inputs, except DIF_IN	1.5		5	pF	1
	$C_{INDIF\_IN}$	DIF_IN differential clock inputs	1.5		2.7	pF	1,5
	$C_{OUT}$	Output pin capacitance			6	pF	1
Clk Stabilization	$T_{STAB}$	From $V_{DD}$ Power-Up and after input clock stabilization or de-assertion of PD# to 1st clock			1	ms	1,2
Input SS Modulation Frequency PCIe	$f_{MODINPCIe}$	Allowable Frequency for PCIe Applications (Triangular Modulation)	30		33	kHz	
Input SS Modulation Frequency non-PCIe	$f_{MODIN}$	Allowable Frequency for non-PCIe Applications (Triangular Modulation)	0		66	kHz	
OE# Latency	$t_{LATO\#}$	DIF start after OE# assertion DIF stop after OE# deassertion	1		3	clocks	1,3
Tdrive_PD#	$t_{DRVPD}$	DIF output enable after PD# de-assertion			300	us	1,3
Tfall	$t_F$	Fall time of single-ended control inputs			5	ns	2
Trise	$t_R$	Rise time of single-ended control inputs			5	ns	2
SMBus Input Low Voltage	$V_{ILSMB}$	$V_{DDSMB} = 3.3V$ , see note 4 for $V_{DDSMB} < 3.3V$			0.6	V	
SMBus Input High Voltage	$V_{IHSMB}$	$V_{DDSMB} = 3.3V$ , see note 5 for $V_{DDSMB} < 3.3V$	2.1		3.6	V	4
SMBus Output Low Voltage	$V_{OLSMB}$	At $I_{PULLUP}$			0.4	V	
SMBus Sink Current	$I_{PULLUP}$	At $V_{OL}$	4			mA	
Nominal Bus Voltage	$V_{DDSMB}$	Bus Voltage	1.7		3.6	V	
SCLK/SDATA Rise Time	$t_{RSMB}$	(Max $V_{IL} - 0.15$ ) to (Min $V_{IH} + 0.15$ )			1000	ns	1
SCLK/SDATA Fall Time	$t_{FSMB}$	(Min $V_{IH} + 0.15$ ) to (Max $V_{IL} - 0.15$ )			300	ns	1
SMBus Operating Frequency	$f_{MAXSMB}$	Maximum SMBus operating frequency			400	kHz	6

<sup>1</sup>Guaranteed by design and characterization, not 100% tested in production.

<sup>2</sup>Control input must be monotonic from 20% to 80% of input swing.

<sup>3</sup>Time from deassertion until outputs are >200 mV.

<sup>4</sup>For  $V_{DDSMB} < 3.3V$ ,  $V_{IHSMB} \geq 0.8 \times V_{DDSMB}$ .

<sup>5</sup>DIF\_IN input.

<sup>6</sup>The differential input clock must be running for the SMBus to be active.

## Electrical Characteristics–DIF 0.7V Low Power HCSL Outputs

TA = T<sub>AMB</sub>, Supply Voltages per normal operation conditions, See Test Loads for Loading Conditions

PARAMETER	SYMBOL	CONDITIONS	MIN	TYP	MAX	UNITS	NOTES
Slew rate	dV/dt	Scope averaging on, fast setting	1.9	3.2	4	V/ns	1,2,3
	dV/dt	Scope averaging on, slow setting	1.4	2.3	3.3	V/ns	1,2,3
Slew rate matching	: dV/dt	Slew rate matching, Scope averaging on		5	20	%	1,2,4
Voltage High	V <sub>HIGH</sub>	Statistical measurement on single-ended signal using oscilloscope math function. (Scope averaging on)	660	779	850	mV	7
Voltage Low	V <sub>LOW</sub>		-150	21	150		7
Max Voltage	V <sub>max</sub>	Measurement on single ended signal using absolute value. (Scope averaging off)		835	1150	mV	7
Min Voltage	V <sub>min</sub>		-300	-42			7
Crossing Voltage (abs)	V <sub>cross_abs</sub>	Scope averaging off	250	409	550	mV	1,5
Crossing Voltage (var)	Δ-V <sub>cross</sub>	Scope averaging off		14	140	mV	1,6

<sup>1</sup>Guaranteed by design and characterization, not 100% tested in production.

<sup>2</sup> Measured from differential waveform

<sup>3</sup> Slew rate is measured through the V<sub>swing</sub> voltage range centered around differential 0V. This results in a +/-150mV window around differential 0V.

<sup>4</sup> Matching applies to rising edge rate for Clock and falling edge rate for Clock#. It is measured using a +/-75mV window centered on the average cross point where Clock rising meets Clock# falling. The median cross point is used to calculate the voltage thresholds the oscilloscope is to use for the edge rate calculations.

<sup>5</sup> V<sub>cross</sub> is defined as voltage where Clock = Clock# measured on a component test board and only applies to the differential rising edge (i.e. Clock rising and Clock# falling).

<sup>6</sup> The total variation of all V<sub>cross</sub> measurements in any particular system. Note that this is a subset of V<sub>cross\_min/max</sub> (V<sub>cross</sub> absolute) allowed. The intent is to limit V<sub>cross</sub> induced modulation by setting Δ-V<sub>cross</sub> to be smaller than V<sub>cross</sub> absolute.

<sup>7</sup> At default SMBus settings.

## Electrical Characteristics–Current Consumption

TA = T<sub>AMB</sub>, Supply Voltages per normal operation conditions, See Test Loads for Loading Conditions

PARAMETER	SYMBOL	CONDITIONS	MIN	TYP	MAX	UNITS	NOTES
Operating Supply Current	I <sub>DDA</sub>	VDDA+VDDR, PLL Mode, @100MHz		4.4	6	mA	1
	I <sub>DD</sub>	VDD, All outputs active @100MHz		14.2	18	mA	1
Powerdown Current	I <sub>DDAPD</sub>	VDDA+VDDR, PLL Mode, @100MHz		0.014	1	mA	1, 2
	I <sub>DDPD</sub>	VDD, Outputs Low/Low		0.9	1.4	mA	1, 2

<sup>1</sup> Guaranteed by design and characterization, not 100% tested in production.

<sup>2</sup> Input clock stopped.

## Electrical Characteristics–Output Duty Cycle, Jitter, Skew and PLL Characteristics

TA = T<sub>AMB</sub>. Supply Voltages per normal operation conditions, See Test Loads for Loading Conditions

PARAMETER	SYMBOL	CONDITIONS	MIN	TYP	MAX	UNITS	NOTES
PLL Bandwidth	BW	-3dB point in High BW Mode	2	2.7	4	MHz	1,5
		-3dB point in Low BW Mode	1	1.4	2	MHz	1,5
PLL Jitter Peaking	t <sub>JPEAK</sub>	Peak Pass band Gain		1.05	2	dB	1
Duty Cycle	t <sub>DC</sub>	Measured differentially, PLL Mode	45	50	55	%	1
Duty Cycle Distortion	t <sub>DCD</sub>	Measured differentially, Bypass Mode @100MHz	-1	-0.1	1	%	1,3
Skew, Input to Output	t <sub>pdBYP</sub>	Bypass Mode, V <sub>T</sub> = 50%	2600	3370	4200	ps	1
	t <sub>pdPLL</sub>	PLL Mode V <sub>T</sub> = 50%	0	112	200	ps	1,4
Skew, Output to Output	t <sub>sk3</sub>	V <sub>T</sub> = 50%		33	50	ps	1,4
Jitter, Cycle to cycle	t <sub>jcyc-cyc</sub>	PLL mode		13	50	ps	1,2
		Additive Jitter in Bypass Mode		0.1	5	ps	1,2

<sup>1</sup> Guaranteed by design and characterization, not 100% tested in production.

<sup>2</sup> Measured from differential waveform

<sup>3</sup> Duty cycle distortion is the difference in duty cycle between the output and the input clock when the device is operated in bypass mode.

<sup>4</sup> All outputs at default slew rate

<sup>5</sup> The MIN/TYP/MAX values of each BW setting track each other, i.e., Low BW MAX will never occur with Hi BW MIN.

## Electrical Characteristics–Phase Jitter Parameters – 12kHz to 20MHz

T<sub>AMB</sub> = over the specified operating range. Supply Voltages per normal operation conditions. See Test Loads for loading conditions.

Parameter	Symbol	Conditions	Minimum	Typical	Maximum	Specification Limit	Units	Notes
12k-20M Additive Phase Jitter, Fan-out Buffer Mode	t <sub>ph12k-20MFOB</sub>	Fan-out Buffer Mode, SSC OFF, 156.25MHz		156		n/a	fs (rms)	1, 2, 3

Notes:

1. Applies to all differential outputs, guaranteed by design and characterization. See Test Loads for measurement setup details.

2. 12kHz to 20MHz brick wall filter.

3. For RMS values additive jitter is calculated by solving for b where  $[b = \sqrt{c^2 - a^2}]$ , a is rms input jitter and c is rms total jitter.



## Electrical Characteristics—Additive PCIe Phase Jitter for Fanout Buffer Mode<sup>[7]</sup>

T<sub>AMB</sub> = over the specified operating range. Supply Voltages per normal operation conditions. See Test Loads for loading conditions.

Parameter	Symbol	Conditions	Minimum	Typical	Maximum	Limit	Units	Notes
Additive PCIe Phase Jitter, Fan-out Buffer Mode (Common Clocked Architecture)	t <sub>phPCIeG1-CC</sub>	PCIe Gen 1 (2.5 GT/s)		1.7	3.0	86	ps (p-p)	1, 2
	t <sub>phPCIeG2-CC</sub>	PCIe Gen 2 Hi Band (5.0 GT/s)		0.033	0.049	3	ps (RMS)	1, 2
		PCIe Gen 2 Lo Band (5.0 GT/s)		0.122	0.199	3.1	ps (RMS)	1, 2
	t <sub>phPCIeG3-CC</sub>	PCIe Gen 3 (8.0 GT/s)		0.059	0.098	1	ps (RMS)	1, 2
	t <sub>phPCIeG4-CC</sub>	PCIe Gen 4 (16.0 GT/s)		0.059	0.098	0.5	ps (RMS)	1, 2, 3, 4
	t <sub>phPCIeG5-CC</sub>	PCIe Gen 5 (32.0 GT/s)		0.023	0.038	0.15	ps (RMS)	1, 2, 3, 5
Additive PCIe Phase Jitter, Fan-out Buffer Mode (SRIS Architecture)	t <sub>phPCIeG1-SRIS</sub>	PCIe Gen 1 (2.5 GT/s)		0.175	0.038	n/a	ps (RMS)	1, 2, 6
	t <sub>phPCIeG2-SRIS</sub>	PCIe Gen 2 (5.0 GT/s)		0.156	0.275	n/a	ps (RMS)	1, 2, 6
	t <sub>phPCIeG3-SRIS</sub>	PCIe Gen 3 (8.0 GT/s)		0.041	0.247	n/a	ps (RMS)	1, 2, 6
	t <sub>phPCIeG4-SRIS</sub>	PCIe Gen 4 (16.0 GT/s)		0.043	0.064	n/a	ps (RMS)	1, 2, 6
	t <sub>phPCIeG5-SRIS</sub>	PCIe Gen 5 (32.0 GT/s)		0.036	0.066	n/a	ps (RMS)	1, 2, 6

Notes:

1. The RefClk jitter is measured after applying the filter functions found in PCI Express Base Specification 5.0, Revision 1.0. See the Test Loads section of the data sheet for the exact measurement setup. The total Ref Clk jitter limits for each data rate are listed for convenience. The worst case results for each data rate are summarized in this table. If oscilloscope data is used, equipment noise is removed from all results.
2. Jitter measurements shall be made with a capture of at least 100,000 clock cycles captured by a real-time oscilloscope (RTO) with a sample rate of 20 GS/s or greater. Broadband oscilloscope noise must be minimized in the measurement. The measured PP jitter is used (no extrapolation) for RTO measurements. Alternately - Jitter measurements may be used with a Phase Noise Analyzer (PNA) extending (flat) and integrating and folding the frequency content up to an offset from the carrier frequency of at least 200 MHz (at 300 MHz absolute frequency) below the Nyquist frequency. For PNA measurements for the 2.5 GT/s data rate, the RMS jitter is converted to peak to peak jitter using a multiplication factor of 8.83. In the case where real-time oscilloscope and PNA measurements have both been done and produce different results the RTO result must be used.
3. SSC spurs from the fundamental and harmonics are removed up to a cutoff frequency of 2 MHz taking care to minimize removal of any non-SSC content
4. Note that 0.7 ps RMS is to be used in channel simulations to account for additional noise in a real system.
5. Note that 0.25 ps RMS is to be used in channel simulations to account for additional noise in a real system.
6. The PCI Express Base Specification 5.0, Revision 1.0 provides the filters necessary to calculate SRIS jitter values, however, it does not provide specification limits, hence the n/a in the Limit column. SRIS values are informative only. In general, a clock operating in an SRIS system must be twice as good as a clock operating in a Common Clock system. For RMS values, twice as good is equivalent to dividing the CC value by  $\sqrt{2}$ . And additional consideration is the value for which to divide by  $\sqrt{2}$ . The conservative approach is to divide the ref clock jitter limit, and the case can be made for dividing the channel simulation values by  $\sqrt{2}$ , if the ref clock is close to the Tx clock input. An example for Gen4 is as follows. A "rule-of-thumb" SRIS limit would be either  $0.5\text{ps RMS}/\sqrt{2} = 0.35\text{ps RMS}$  if the clock chip is far from the clock input, or  $0.7\text{ps RMS}/\sqrt{2} = 0.5\text{ps RMS}$  if the clock chip is near the clock input.
7. Additive jitter for RMS values is calculated by solving for b where  $b = \sqrt{c^2 - a^2}$ , and a is rms input jitter and c is rms output jitter.

### Additive Phase Jitter Plot: 125M (12kHz to 20MHz)

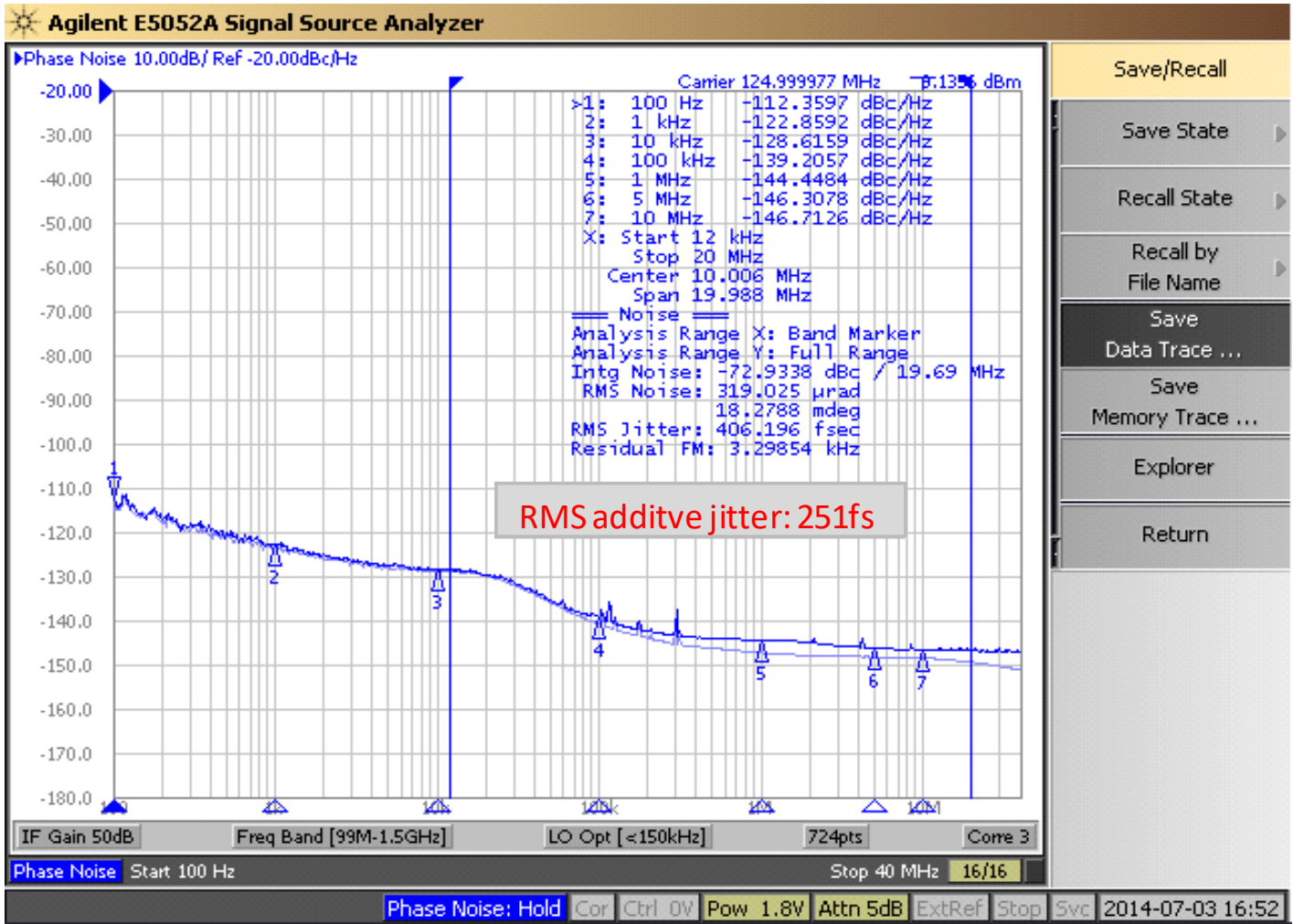

## General SMBus Serial Interface Information

### How to Write

- Controller (host) sends a start bit
- Controller (host) sends the write address
- Renesas clock will **acknowledge**
- Controller (host) sends the beginning byte location = N
- Renesas clock will **acknowledge**
- Controller (host) sends the byte count = X
- Renesas clock will **acknowledge**
- Controller (host) starts sending Byte N through Byte N+X-1
- Renesas clock will **acknowledge** each byte **one at a time**
- Controller (host) sends a Stop bit

### How to Read

- Controller (host) will send a start bit
- Controller (host) sends the write address
- Renesas clock will **acknowledge**
- Controller (host) sends the beginning byte location = N
- Renesas clock will **acknowledge**
- Controller (host) will send a separate start bit
- Controller (host) sends the read address
- Renesas clock will **acknowledge**
- Renesas clock will send the data byte count = X
- Renesas clock sends Byte N+X-1
- Renesas clock sends **Byte 0 through Byte X (if X<sub>(H)</sub> was written to Byte 8)**
- Controller (host) will need to acknowledge each byte
- Controller (host) will send a not acknowledge bit
- Controller (host) will send a stop bit

Index Block Write Operation			
Controller (Host)		Renesas (Slave/Receiver)	
T	starT bit		
Slave Address			
WR	WRite		
Beginning Byte = N			ACK
			ACK
Data Byte Count = X			ACK
Beginning Byte N		X Byte	ACK
O			O
O			O
O			O
Byte N + X - 1			ACK
P	stoP bit		

Index Block Read Operation			
Controller (Host)		Renesas	
T	starT bit		
Slave Address			
WR	WRite		
Beginning Byte = N			ACK
			ACK
RT	Repeat starT		
Slave Address			
RD	ReaD		ACK
ACK			Data Byte Count=X
			Beginning Byte N
ACK		X Byte	O
O			O
O			O
O			
			Byte N + X - 1
N	Not acknowledge		
P	stoP bit		

**Note: SMBus Address is 1101101x, where x is the read/write bit.**

**SMBus Table: Output Enable Register <sup>1</sup>**

Byte 0	Name	Control Function	Type	0	1	Default
Bit 7	Reserved					1
Bit 6	Reserved					1
Bit 5	DIF OE1	Output Enable	RW	Low/Low	Enabled	1
Bit 4	Reserved					1
Bit 3	DIF OE0	Output Enable	RW	Low/Low	Enabled	1
Bit 2	Reserved					1
Bit 1	Reserved					1
Bit 0	Reserved					1

1. A low on these bits will override the OE# pin and force the differential output Low/Low

**SMBus Table: PLL Operating Mode and Output Amplitude Control Register**

Byte 1	Name	Control Function	Type	0	1	Default
Bit 7	PLLMODERB1	PLL Mode Readback Bit 1	R	See PLL Operating Mode Table		Latch
Bit 6	PLLMODERB0	PLL Mode Readback Bit 0	R			Latch
Bit 5	PLLMODE_SWCNTRL	Enable SW control of PLL Mode	RW	Values in B1[7:6] set PLL Mode	Values in B1[4:3] set PLL Mode	0
Bit 4	PLLMODE1	PLL Mode Control Bit 1	RW <sup>1</sup>	See PLL Operating Mode Table		0
Bit 3	PLLMODE0	PLL Mode Control Bit 0	RW <sup>1</sup>			0
Bit 2	Reserved					1
Bit 1	AMPLITUDE 1	Controls Output Amplitude	RW	00 = 0.6V	01 = 0.7V	1
Bit 0	AMPLITUDE 0		RW	10 = 0.8V	11 = 0.9V	0

1. B1[5] must be set to a 1 for these bits to have any effect on the part.

**SMBus Table: DIF Slew Rate Control Register**

Byte 2	Name	Control Function	Type	0	1	Default
Bit 7	Reserved					1
Bit 6	Reserved					1
Bit 5	SLEWRATESEL DIF1	Slew Rate Selection	RW	Slow setting	Fast setting	1
Bit 4	Reserved					1
Bit 3	SLEWRATESEL DIF0	Slew Rate Selection	RW	Slow setting	Fast setting	1
Bit 2	Reserved					1
Bit 1	Reserved					1
Bit 0	Reserved					1

**SMBus Table: Frequency Select Control Register**

Byte 3	Name	Control Function	Type	0	1	Default
Bit 7	Reserved					1
Bit 6	Reserved					1
Bit 5	FREQ_SEL_EN	Enable SW selection of frequency	RW	SW frequency change disabled	SW frequency change enabled	0
Bit 4	FSEL1	Freq. Select Bit 1	RW <sup>1</sup>	See Frequency Select Table		0
Bit 3	FSEL0	Freq. Select Bit 0	RW <sup>1</sup>			0
Bit 2	Reserved					1
Bit 1	Reserved					1
Bit 0	SLEWRATESEL FB	Adjust Slew Rate of FB	RW	Slow setting	Fast setting	1

1. B3[5] must be set to a 1 for these bits to have any effect on the part.

**Byte 4 is Reserved and reads back 'hFF'**

**SMBus Table: Revision and Vendor ID Register**

Byte 5	Name	Control Function	Type	0	1	Default
Bit 7	RID3	Revision ID	R	A rev = 0000		0
Bit 6	RID2		R			0
Bit 5	RID1		R			0
Bit 4	RID0		R			0
Bit 3	VID3	VENDOR ID	R	0001 = IDT		0
Bit 2	VID2		R			0
Bit 1	VID1		R			0
Bit 0	VID0		R			1

**SMBus Table: Device Type/Device ID**

Byte 6	Name	Control Function	Type	0	1	Default
Bit 7	Device Type1	Device Type	R	00 = FGx, 01 = DBx, 10 = DMx, 11= Reserved		0
Bit 6	Device Type0		R			1
Bit 5	Device ID5	Device ID	R	000100 binary or 02 hex		0
Bit 4	Device ID4		R			0
Bit 3	Device ID3		R			0
Bit 2	Device ID2		R			0
Bit 1	Device ID1		R			1
Bit 0	Device ID0		R			0

**SMBus Table: Byte Count Register**

Byte 7	Name	Control Function	Type	0	1	Default
Bit 7		Reserved				0
Bit 6		Reserved				0
Bit 5		Reserved				0
Bit 4	BC4	Byte Count Programming	RW	Writing to this register will configure how many bytes will be read back, default is = 8 bytes.		0
Bit 3	BC3		RW			1
Bit 2	BC2		RW			0
Bit 1	BC1		RW			0
Bit 0	BC0		RW			0

## Marking Diagrams

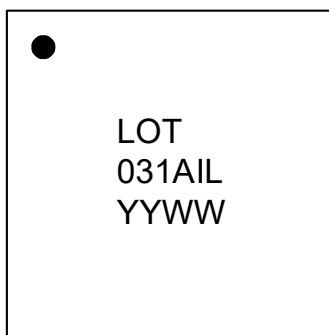
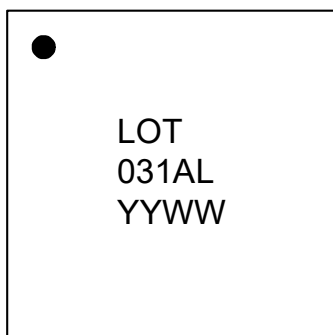

### Notes:

1. "LOT" is the lot sequence number.
2. YYWW is the last two digits of the year and week that the part was assembled.
3. Line 2: truncated part number
4. "L" denotes RoHS compliant package.
5. "I" denotes industrial temperature range device.

## Thermal Characteristics

PARAMETER	SYMBOL	CONDITIONS	PKG	TYP VALUE	UNITS	NOTES
Thermal Resistance	$\theta_{JC}$	Junction to Case	NLG20 NLG24	62	°C/W	1
	$\theta_{Jb}$	Junction to Base		5.4	°C/W	1
	$\theta_{JA0}$	Junction to Air, still air		50	°C/W	1
	$\theta_{JA1}$	Junction to Air, 1 m/s air flow		43	°C/W	1
	$\theta_{JA3}$	Junction to Air, 3 m/s air flow		39	°C/W	1
	$\theta_{JA5}$	Junction to Air, 5 m/s air flow		38	°C/W	1

<sup>1</sup>ePad soldered to board

## Package Outline Drawings

The package outline drawings are located at the end of this document and are accessible from the Renesas website. The package information is the most current data available and is subject to change without revision of this document.

### 24-VFQFPN (NLG24P1)

## Ordering Information

Part / Order Number	Shipping Packaging	Package	Temperature
9DBV0231AKLF	Tubes	24-pin VFQFPN	0 to +70° C
9DBV0231AKLFT	Tape and Reel	24-pin VFQFPN	0 to +70° C
9DBV0231AKILF	Tubes	24-pin VFQFPN	-40 to +85° C
9DBV0231AKILFT	Tape and Reel	24-pin VFQFPN	-40 to +85° C

“LF” suffix to the part number are the Pb-Free configuration and are RoHS compliant.

“A” is the device revision designator (will not correlate with the datasheet revision).

## Revision History

Revision Date	Description
August 13, 2012	<ol style="list-style-type: none"> <li>Updated electrical characteristics tables.</li> <li>Move to final.</li> </ol>
September 16, 2014	<ol style="list-style-type: none"> <li>Changed VIH min. from 0.65*VDD to 0.75*VDD</li> <li>Changed VIL max. from 0.35*VDD to 0.25*VDD</li> <li>Added missing mid-level input voltage spec (VIM) of 0.4*VDD to 0.6*VDD.</li> <li>Changed Shipping Packaging from "Trays" to "Tubes".</li> <li>Reformatted to new template</li> </ol>
April 3, 2015	<ol style="list-style-type: none"> <li>Updated block diagram with new format showing individual outputs instead of bussed outputs.</li> <li>Updated pin out and pin descriptions to show ePad on package connected to ground.</li> <li>Updated front page text to standard format for these devices. Added explicit bullet indicated Spread Spectrum compatibility. Changed data sheet title, etc.</li> <li>Added additive phase jitter plot and updated phase jitter spec table.</li> </ol>
August 10, 2015	<ol style="list-style-type: none"> <li>Replaced "Driving LVDS" with "Alternate Terminations", adding reference to AN-891.</li> <li>Updated "Clock Input Parameters Table" correcting inconsistency with PCIe SIG specifications.</li> <li>Widened allowable input frequency at each PLL mode frequency.</li> <li>Updated NLG24 package drawing with actual package info instead of generic drawing.</li> </ol>
November 5, 2015	<ol style="list-style-type: none"> <li>Minor typographical corrections throughout the data sheet</li> <li>Updated test load diagram to generic diagram. Length of test load listed outside the drawing.</li> <li>Minor updates to electrical tables for formatting. Removed Schmitt trigger info and output high/low voltage specifications for single-ended outputs, since this part does not have any.</li> <li>"Low-Power HCSL Outputs" table: corrected inversion of slew rate setting with specifications. Changed reference from 2 V/ns and 3 V/ns to slow setting and fast setting. Also change references in SMBus Bytes[3:2]</li> <li>"Low-Power HCSL Outputs" table: Removed Vswing parameter since this is an input parameter and is covered in "Clock Input Parameters" Table.</li> <li>Reduced current consumption limits.</li> <li>Minor updates to other electrical tables.</li> </ol>
April 28, 2016	<ol style="list-style-type: none"> <li>Updated max frequency of 100MHz PLL mode to 140MHz</li> <li>Updated max frequency of 125MHz PLL mode to 175MHz</li> <li>Updated max frequency of 50MHz PLL mode to 65MHz</li> </ol>
July 30, 2021	<ol style="list-style-type: none"> <li>Updated document title.</li> <li>Updated Recommended Applications.</li> <li>Updated Key Specifications.</li> <li>Updated Package Outline Drawings section.</li> <li>Updated Phase Jitter tables.</li> </ol>

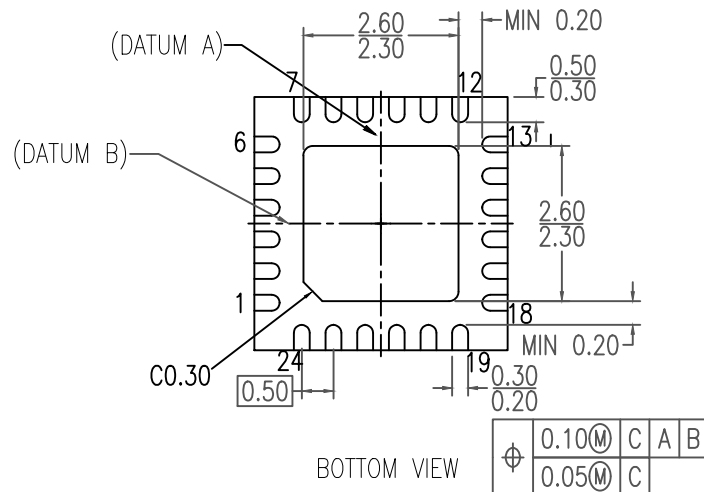
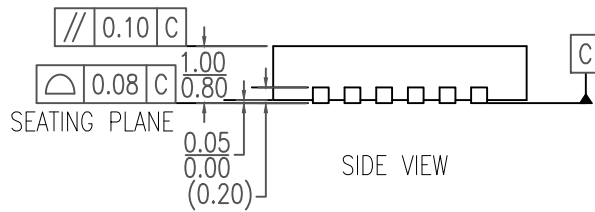
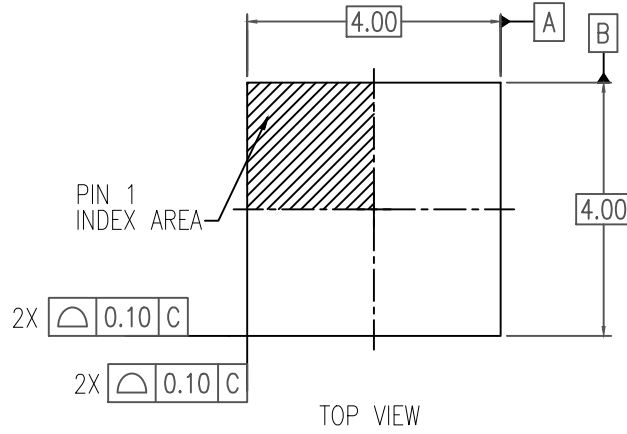

NOTES:

1. DIMENSIONING AND TOLERANCING CONFORME TO ASME Y14.5M-1994.
2. ALL DIMENSIONS ARE IN MILLIMETERS.



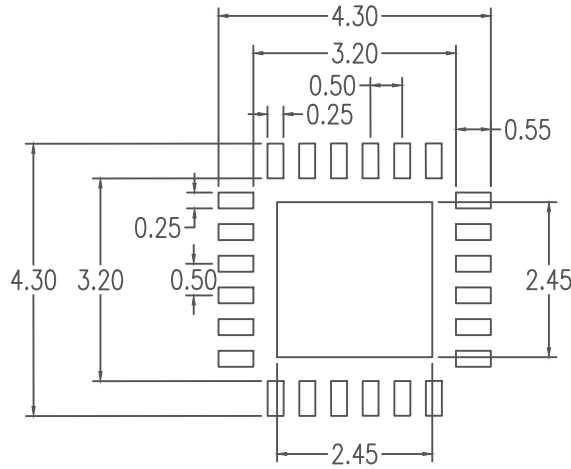

RECOMMENDED LAND PATTERN DIMENSION

NOTES:

1. ALL DIMENSIONS ARE IN MM. ANGLES IN DEGREES.
2. TOP DOWN VIEW, AS VIEWED ON PCB.
3. LAND PATTERN RECOMMENDATION PER IPC-7351B GENERIC REQUIREMENT FOR SURFACE MOUNT DESIGN AND LAND PATTERN.

Package Revision History		
Date Created	Rev No.	Description
Sept 9, 2016	Rev 01	Add Chamfer on Epad
Sept 13, 2018	Rev 02	New Format, Recalculate Land Pattern Change QFN to VFQFPN