

General Description

The 9DMU0141 is a member of IDT's SOC-Friendly 1.5V Ultra-Low-Power (ULP) PCIe Gen1-2-3 family. It has integrated output terminations providing $Z_o=100\Omega$ for direct connection to 100ohm transmission lines. The output has an OE# pin for optimal system control and power management. The part provides asynchronous or glitch-free switching modes.

Recommended Application

2:1 1.5V PCIe Gen1-2-3 Clock Mux

Output Features

- 1 – Low-Power (LP) HCSL DIF pair w/ $Z_o=100\Omega$

Key Specifications

- DIF *additive* cycle-to-cycle jitter <5ps
- DIF phase jitter is PCIe Gen1-2-3 compliant
- 125MHz additive phase jitter 535fs rms typical (12kHz to 20MHz)

Features/Benefits

- LP-HCSL output w/integrated terminations; saves 4 resistors compared to standard HCSL output
- 1.5V operation; 11mW typical power consumption
- Selectable asynchronous or glitch-free switching; allows the mux to be selected at power up even if both inputs are not running, then transition to glitch-free switching mode
- Spread Spectrum Compatible; supports EMI reduction
- OE# pins; support DIF power management
- HCSL differential inputs; can be driven by common clock sources
- 1MHz to 167MHz operating frequency
- Space saving 16-pin 3x3mm VFQFPN; minimal board space

Block Diagram

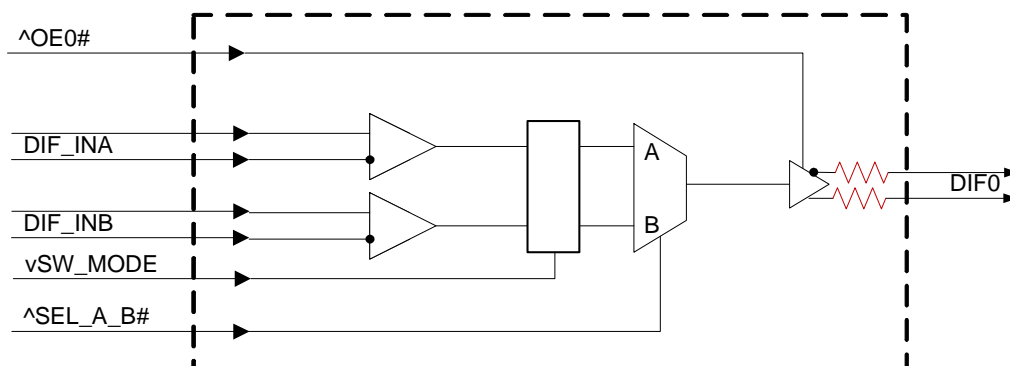

Pin Configuration

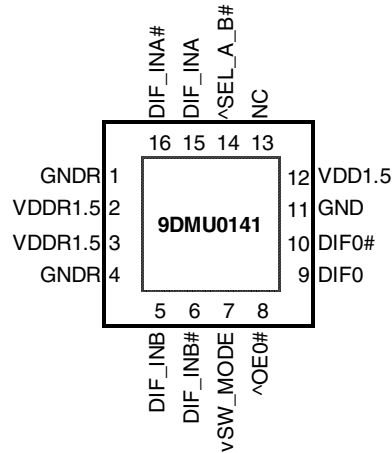

16-pin VFQFPN, 3x3 mm, 0.5mm pitch

^ prefix indicates internal 120KOhm pull up resistor
 v prefix indicates internal 120KOhm pull down resistor

Note: Paddle may be connected to ground for thermal purposes. It is not required electrically.

Power Management Table

OEx# Pin	DIF_IN	DIFx	
		True O/P	Comp. O/P
0	Running	Running	Running
1	Running	Low	Low

Power Connections

Pin Number		Description
VDD	GND	
2	1	Input A receiver analog
3	4	Input B receiver analog
12	11	DIF outputs

Note: Pins 2 and 3 should be decoupled separately to pins 1 and 4 respectively.

Pin Descriptions

Pin#	Pin Name	Type	Pin Description
1	GNDR	GND	Analog Ground pin for the differential input (receiver)
2	VDDR1.5	PWR	1.5V power for differential input clock (receiver). This VDD should be treated as an Analog power rail and filtered appropriately.
3	VDDR1.5	PWR	1.5V power for differential input clock (receiver). This VDD should be treated as an Analog power rail and filtered appropriately.
4	GNDR	GND	Analog Ground pin for the differential input (receiver)
5	DIF_INB	IN	HCSL Differential True input
6	DIF_INB#	IN	HCSL Differential Complement Input
7	vSW_MODE	IN	Switch Mode. This pin selects either asynchronous or glitch-free switching of the mux. Use asynchronous mode if 0 or 1 of the input clocks is running. Use glitch-free mode if both input clocks are running. This pin has an internal pull down resistor of ~120kohms. 0 = asynchronous mode 1 = glitch-free mode
8	^OE0#	IN	Active low input for enabling DIF pair 0. This pin has an internal pull-up resistor. 1 =disable outputs, 0 = enable outputs
9	DIF0	OUT	Differential true clock output
10	DIF0#	OUT	Differential Complementary clock output
11	GND	GND	Ground pin.
12	VDD1.5	PWR	Power supply, nominally 1.5V
13	NC	N/A	No Connection.
14	^SEL_A_B#	IN	Input to select differential input clock A or differential input clock B. This input has an internal pull-up resistor. 0 = Input B selected, 1 = Input A selected.
15	DIF_INA	IN	HCSL Differential True input
16	DIF_INA#	IN	HCSL Differential Complement Input

Test Loads

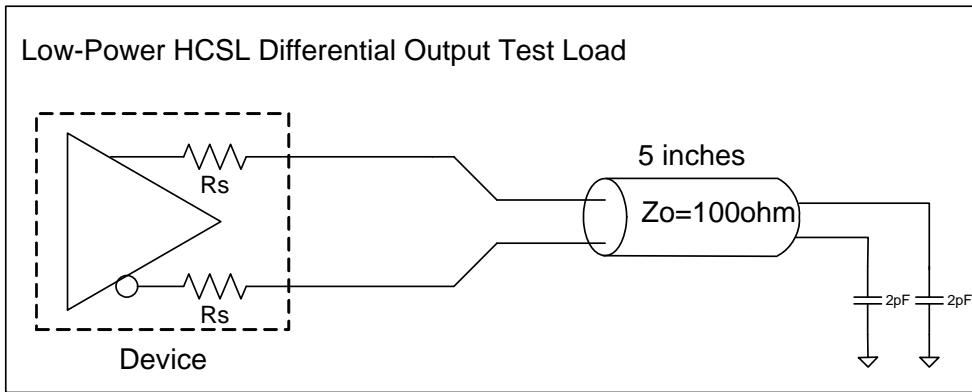

Driving LVDS

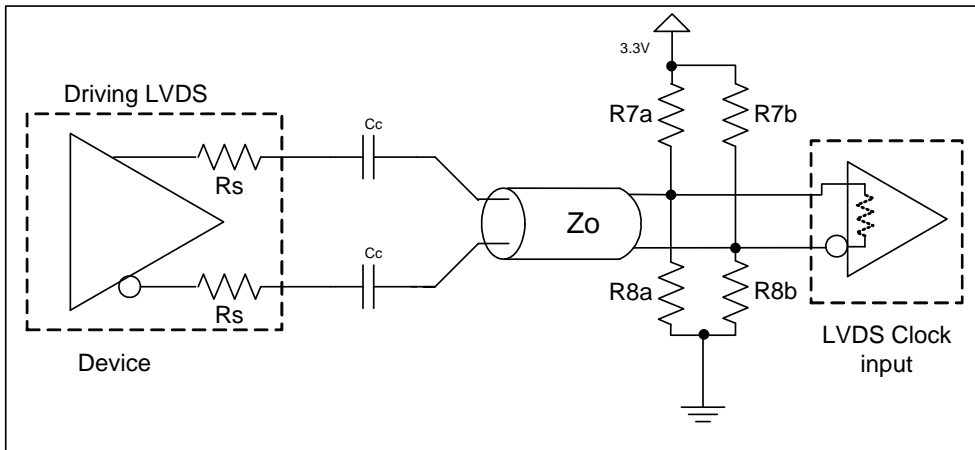

Driving LVDS inputs

Component	Value		Note
	Receiver has termination	Receiver does not have termination	
R7a, R7b	10K ohm	140 ohm	
R8a, R8b	5.6K ohm	75 ohm	
C_c	0.1 μF	0.1 μF	
V_{cm}	1.2 volts	1.2 volts	

Electrical Characteristics–Absolute Maximum Ratings

PARAMETER	SYMBOL	CONDITIONS	MIN	TYP	MAX	UNITS	NOTES
Supply Voltage	VDDx		-0.5		2	V	1,2
Input Voltage	V _{IN}		-0.5		V _{DD} +0.5	V	1,3
Input High Voltage, SMBus	V _{IHSMB}	SMBus clock and data pins			3.3	V	1
Storage Temperature	T _s		-65		150	°C	1
Junction Temperature	T _j				125	°C	1
Input ESD protection	ESD prot	Human Body Model	2000			V	1

¹Guaranteed by design and characterization, not 100% tested in production.

²Operation under these conditions is neither implied nor guaranteed.

³Not to exceed 2.0V.

Electrical Characteristics–Input/Supply/Common Parameters–Normal Operating Conditions

T_A = T_{AMB}, Supply Voltages per normal operation conditions, See Test Loads for Loading Conditions

PARAMETER	SYMBOL	CONDITIONS	MIN	TYP	MAX	UNITS	NOTES
Supply Voltage	VDDx	Supply voltage for core and analog	1.425	1.5	1.575	V	
Ambient Operating Temperature	T _{AMB}	Industrial range	-40	25	85	°C	1
Input High Voltage	V _{IH}	Single-ended inputs, except SMBus	0.75 V _{DD}		V _{DD} + 0.3	V	
Input Low Voltage	V _{IL}	Single-ended inputs, except SMBus	-0.3		0.25 V _{DD}	V	
Input Current	I _{IN}	Single-ended inputs, V _{IN} = GND, V _{IN} = VDD	-5		5	µA	
	I _{INP}	Single-ended inputs V _{IN} = 0 V; Inputs with internal pull-up resistors V _{IN} = VDD; Inputs with internal pull-down resistors	-200		200	µA	
Input Frequency	F _{in}		1		167	MHz	2
Pin Inductance	L _{pin}				7	nH	1
Capacitance	C _{IN}	Logic Inputs, except DIF_IN	1.5		5	pF	1
	C _{INDIF_IN}	DIF_IN differential clock inputs	1.5		2.7	pF	1,4
	C _{OUT}	Output pin capacitance			6	pF	1
Clk Stabilization	T _{STAB}	From V _{DD} Power-Up and after input clock stabilization or de-assertion of PD# to 1st clock			1	ms	1,2
Input SS Modulation Frequency PCIe	f _{MODINPCIe}	Allowable Frequency for PCIe Applications (Triangular Modulation)	30		33	kHz	
Input SS Modulation Frequency non-PCIe	f _{MODIN}	Allowable Frequency for non-PCIe Applications (Triangular Modulation)	0		66	kHz	
OE# Latency	t _{LATOE#}	DIF start after OE# assertion DIF stop after OE# deassertion	1		3	clocks	1,3
T _{fall}	t _F	Fall time of single-ended control inputs			5	ns	2
T _{rise}	t _R	Rise time of single-ended control inputs			5	ns	2

¹Guaranteed by design and characterization, not 100% tested in production.

²Control input must be monotonic from 20% to 80% of input swing.

³Time from deassertion until outputs are >200 mV

⁴DIF_IN input

Electrical Characteristics–Clock Input Parameters

TA = T_{AMB}, Supply Voltages per normal operation conditions, See Test Loads for Loading Conditions

PARAMETER	SYMBOL	CONDITIONS	MIN	TYP	MAX	UNITS	NOTES
Input High Voltage - DIF_IN	V _{IHDIF}	Differential inputs (single-ended measurement)	300	750	1150	mV	1
Input Low Voltage - DIF_IN	V _{ILDIF}	Differential inputs (single-ended measurement)	V _{SS} - 300	0	300	mV	1
Input Common Mode Voltage - DIF_IN	V _{COM}	Common Mode Input Voltage	200		725	mV	1
Input Amplitude - DIF_IN	V _{SWING}	Peak to Peak value (V _{IHDIF} - V _{ILDIF})	300		1450	mV	1
Input Slew Rate - DIF_IN	dv/dt	Measured differentially	0.35		8	V/ns	1,2
Input Leakage Current	I _{IN}	V _{IN} = V _{DD} , V _{IN} = GND	-5		5	uA	
Input Duty Cycle	d _{in}	Measurement from differential waveform	45	50	55	%	1
Input Jitter - Cycle to Cycle	J _{DIFin}	Differential Measurement	0		150	ps	1

¹ Guaranteed by design and characterization, not 100% tested in production.

² Slew rate measured through +/-75mV window centered around differential zero

Electrical Characteristics–DIF Low-Power HCSL Outputs

TA = T_{AMB}, Supply Voltages per normal operation conditions, See Test Loads for Loading Conditions

PARAMETER	SYMBOL	CONDITIONS	MIN	TYP	MAX	UNITS	NOTES
Slew rate	dV/dt	Scope averaging on, fast setting	1.2	2.4	3.6	V/ns	1,2,3
Slew rate matching	ΔdV/dt	Slew rate matching, Scope averaging on		13	20	%	1,2,4
Voltage High	V _{HIGH}	Statistical measurement on single-ended signal using oscilloscope math function. (Scope averaging on)	550	755	850	mV	
Voltage Low	V _{LOW}		-150	21	150		
Max Voltage	V _{max}	Measurement on single ended signal using absolute value. (Scope averaging off)		766	1150	mV	
Min Voltage	V _{min}		-300	-25			
Vswing	V _{swing}	Scope averaging off	300	1469		mV	1,2
Crossing Voltage (abs)	V _{cross_abs}	Scope averaging off	250	367	550	mV	1,5
Crossing Voltage (var)	Δ-V _{cross}	Scope averaging off		12	140	mV	1,6

¹ Guaranteed by design and characterization, not 100% tested in production.

² Measured from differential waveform

³ Slew rate is measured through the V_{swing} voltage range centered around differential 0V. This results in a +/-150mV window around differential 0V.

⁴ Matching applies to rising edge rate for Clock and falling edge rate for Clock#. It is measured using a +/-75mV window centered on the average cross point where Clock rising meets Clock# falling. The median cross point is used to calculate the voltage thresholds the oscilloscope is to use for the edge rate calculations.

⁵ V_{cross} is defined as voltage where Clock = Clock# measured on a component test board and only applies to the differential rising edge (i.e. Clock rising and Clock# falling).

⁶ The total variation of all V_{cross} measurements in any particular system. Note that this is a subset of V_{cross_min/max} (V_{cross} absolute) allowed. The intent is to limit V_{cross} induced modulation by setting Δ-V_{cross} to be smaller than V_{cross} absolute.

Electrical Characteristics–Current Consumption

TA = T_{AMB}, Supply Voltages per normal operation conditions, See Test Loads for Loading Conditions

PARAMETER	SYMBOL	CONDITIONS	MIN	TYP	MAX	UNITS	NOTES
Operating Supply Current	I _{DD}	VDD, All outputs active @100MHz		7	11	mA	1
Powerdown Current	I _{DDPD}	VDD, all outputs disabled		1.4	2.5	mA	1, 2

¹ Guaranteed by design and characterization, not 100% tested in production.

² Input clock stopped.

Electrical Characteristics–Output Duty Cycle, Jitter, Skew and PLL Characteristics

TA = T_{AMB}, Supply Voltages per normal operation conditions, See Test Loads for Loading Conditions

PARAMETER	SYMBOL	CONDITIONS	MIN	TYP	MAX	UNITS	NOTES
Duty Cycle Distortion	t _{DCD}	Measured differentially @100MHz	-1	-0.2	1	%	1,3
Skew, Input to Output	t _{pdBYP}	Bypass Mode, V _T = 50%	2196	2923	3978	ps	1
Skew, Output to Output	t _{sk3}	V _T = 50%		N/A	N/A	ps	1
Jitter, Cycle to cycle	t _{cycc-cyc}	Additive Jitter		0.1	8	ps	1,2

¹ Guaranteed by design and characterization, not 100% tested in production.

² Measured from differential waveform

³ Duty cycle distortion is the difference in duty cycle between the output and the input clock when the device is operated in bypass mode.

Electrical Characteristics–Phase Jitter Parameters

TA = T_{AMB}, Supply Voltages per normal operation conditions, See Test Loads for Loading Conditions

PARAMETER	SYMBOL	CONDITIONS	MIN	TYP	MAX	INDUSTRY LIMIT	UNITS	Notes	
Additive Phase Jitter, Bypass Mode	t _{jphPCIeG1}	PCIe Gen 1		0.4	5	N/A	ps (p-p)	1,2,3,5	
	t _{jphPCIeG2}	PCIe Gen 2 Lo Band 10kHz < f < 1.5MHz		0.4	0.6	N/A	ps (rms)	1,2,3,4,5	
		PCIe Gen 2 High Band 1.5MHz < f < Nyquist (50MHz)		0.1	0.2	N/A	ps (rms)	1,2,3,4	
	t _{jphPCIeG3}	PCIe Gen 3 (PLL BW of 2-4 or 2-5MHz, CDR = 10MHz)		0.050	0.1	N/A	ps (rms)	1,2,3,4	
	t _{jph125M0}	125MHz, 1.5MHz to 10MHz, -20dB/decade rollover < 1.5MHz, -40db/decade rolloff > 10MHz			365	380	N/A	fs (rms)	1,6
	t _{jph125M1}	125MHz, 12KHz to 20MHz, -20dB/decade rollover < 1.5MHz, -40db/decade rolloff > 10MHz			535	550	N/A	fs (rms)	1,6

¹ Guaranteed by design and characterization, not 100% tested in production.

² See <http://www.pcisig.com> for complete specs

³ Sample size of at least 100K cycles. This figures extrapolates to 108ps pk-pk @ 1M cycles for a BER of 1-12.

⁴ For RMS figures, additive jitter is calculated by solving the following equation: Additive jitter = SQRT[(total jitter)² - (input jitter)²]

⁵ Driven by 9FGU0831 or equivalent

⁶ Rohde&Schartz SMA100

Marking Diagrams

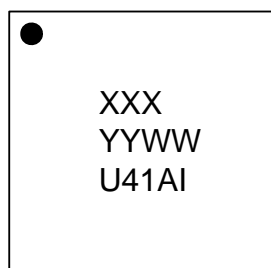

Notes:

1. "XXX" is the last 3 characters of the lot number.
2. "YYWW" is the last two digits of the year and week that the part was assembled.
3. Line 3: truncated part number
4. "I" denotes industrial temperature grade.

Thermal Characteristics

PARAMETER	SYMBOL	CONDITIONS	PKG	TYP VALUE	UNITS	NOTES
Thermal Resistance	θ_{JC}	Junction to Case	NLG16	66	°C/W	1
	θ_{Jb}	Junction to Base		5	°C/W	1
	θ_{JA0}	Junction to Air, still air		63	°C/W	1
	θ_{JA1}	Junction to Air, 1 m/s air flow		56	°C/W	1
	θ_{JA3}	Junction to Air, 3 m/s air flow		51	°C/W	1
	θ_{JA5}	Junction to Air, 5 m/s air flow		49	°C/W	1

¹ePad soldered to board

Package Outline and Package Dimensions (NLG16)

Package dimensions are kept current with JEDEC Publication No. 95

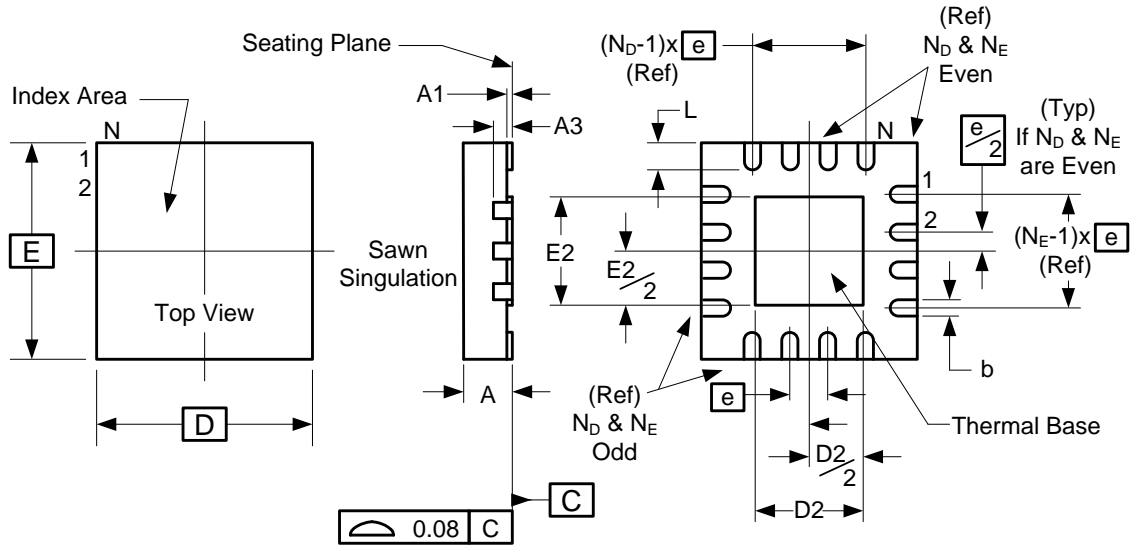

Symbol	Millimeters	
	Min	Max
A	0.80	1.00
A1	0	0.05
A3	0.20 Reference	
b	0.18	0.30
e	0.50 BASIC	
N	16	
N_D	4	
N_E	4	
D x E BASIC	3.00 x 3.00	
D2	1.55	1.80
E2	1.55	1.80
L	0.30	0.50

Ordering Information

Part / Order Number	Shipping Packaging	Package	Temperature
9DMU0141AKILF	Trays	16-pin VFQFPN	-40 to +85° C
9DMU0141AKILFT	Tape and Reel	16-pin VFQFPN	-40 to +85° C

“LF” to the suffix denotes Pb-Free configuration, RoHS compliant.

“A” is the device revision designator (will not correlate with the datasheet revision).

Revision History

Rev.	Initiator	Issue Date	Description	Page #
A	RDW	9/29/2014	1. Update front page text and electrical tables with char data. 2. Update pinout diagram with note about package paddle. 3. Move to final.	Various

