

# San Ace 92WF 9WFA type

## Oil Proof Fan

**Features**

**High Airflow and High Static Pressure**

This fan delivers a maximum airflow of 3.1 m<sup>3</sup>/min and a maximum static pressure of 380 Pa.

**Oil-proof**

The windings and electronic components are structurally protected by materials with excellent oil resistance, and stable operation is maintained even in harsh oil mist environments.



**92 x 92 x 32 mm**

**Specifications**

The models listed below **have ribs and pulse sensors.**

Model no.	Rated voltage [V]	Operating voltage range [V]	Rated current [A]	Rated input [W]	Rated speed [min <sup>-1</sup> ]	Max. airflow [m <sup>3</sup> /min] [CFM]	Max. static pressure [Pa] [inchH <sub>2</sub> O]	SPL [dB(A)]	Operating temperature [°C]	Expected life [h]
9WFA0924G2001	24	12 to 27.6	0.58	13.9	9600	3.1 109.5	380 1.53	63	-20 to +70	40000/60°C (70000/40°C)

Models with the following sensor specifications are also available as options: **Without sensor** **Lock sensor**

**Common Specifications**

- Material ..... Frame: Plastic (Flammability: UL 94V-0), Impeller: Plastic (Flammability: UL 94V-0)
- Expected life ..... Refer to specifications  
(L10 life: 90% survival rate for continuous operation in free air at 60°C, rated voltage)  
Expected life at 40°C is for reference only.
- Motor protection system ..... Current blocking function and reverse polarity protection
- Dielectric strength ..... 50/60 Hz, 500 VAC, for 1 minute (between lead wire conductors and frame)
- Sound pressure level (SPL) ..... At 1 m away from the air inlet
- Operating temperature ..... Refer to specifications (Non-condensing)
- Storage temperature ..... -30 to +70°C (Non-condensing)
- Lead wire ..... ⊕ Red ⊖ Black Sensor Yellow
- Mass ..... 205 g

**Airflow - Static Pressure Characteristics**

• Operating voltage range

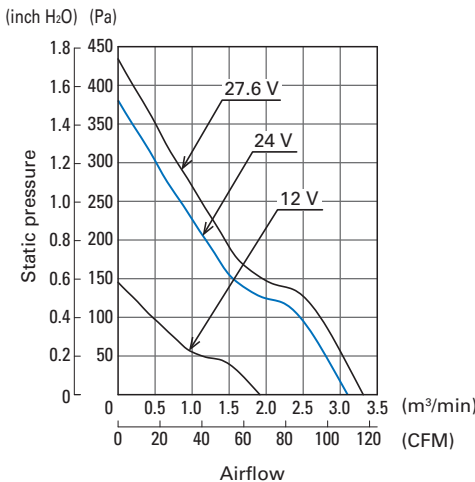

## Specifications for Pulse Sensors

Output circuit: Open collector

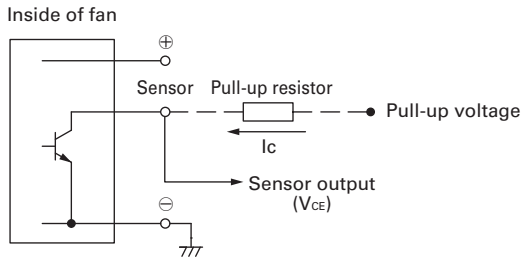

$V_{CE} = +27.6 \text{ V max.}$   
 $I_c = 5 \text{ mA max. [} V_{OL} = V_{CE} (\text{SAT}) = 1.0 \text{ V max.}]$

Output waveform (Need pull-up resistor)

In case of steady running

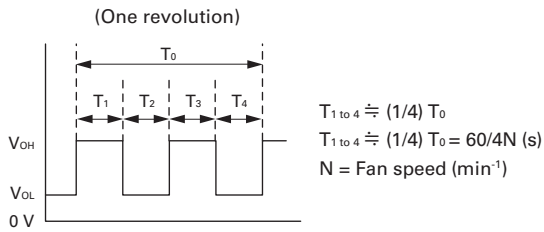

## Dimensions (unit: mm)

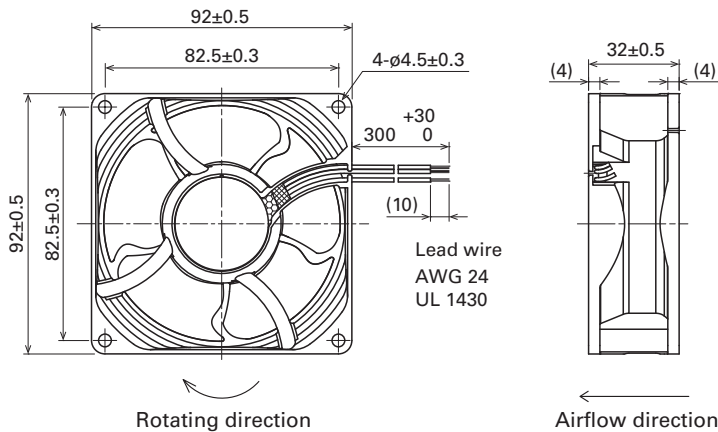

## Reference Dimensions of Mounting Holes and Vent Opening (unit: mm)

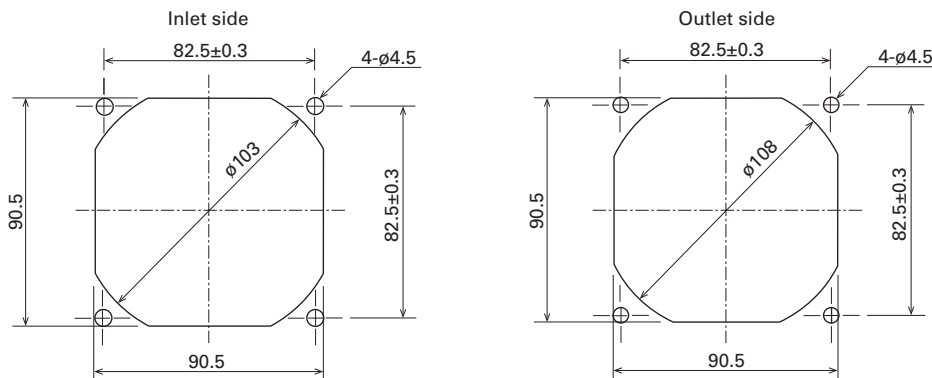

### Notice

- Please read the "Safety Precautions" on our website before using the product.
- The products shown in this catalog are subject to Japanese Export Control Law. Diversion contrary to the law of exporting country is prohibited.
- For protecting fan bearings against electrolytic corrosion near strong electromagnetic noise sources, we provide effective countermeasures such as Electrolytic Corrosion Proof Fans and EMC guards. Contact us for details.

**SANYO DENKI CO.,LTD.** 3-33-1 Minami-Otsuka, Toshima-ku, Tokyo 170-8451, Japan TEL: +81 3 5927 1020

<https://www.sanyodenki.com>

The names of companies and/or their products specified in this catalog are the trade names, and/or trademarks and/or registered trademarks of such respective companies.

"San Ace" is a trademark of SANYO DENKI CO.,LTD.

Specifications are subject to change without notice.

CATALOG No. C1096B001 '19.5