

ASIL-Compliant Hall-Effect Wheel Speed Sensor IC with Speed and Direction Output

FEATURES AND BENEFITS

- **Hall-effect technology** allows ease of use for ring magnet and ferrous target sensing
- **Integrated capacitor** in a single overmolded miniature package provides greater EMC robustness
- **SolidSpeed Digital Architecture** supports advanced algorithms, maintaining pitch accuracy during dynamic air gap disturbances
- **ASIL B rating** based on integrated diagnostics and certified safety design process
- **User-accessible EEPROM** for device traceability



PACKAGE:



2-Pin SIP
(suffix UB)

Not to scale

DESCRIPTION

The A19300 is an optimized Hall-effect integrated circuit (IC) that provides a user-friendly two-wire solution for applications where pitch accuracy is important for the determination of speed and direction of the sensed target. The small package includes an integrated capacitor and Hall-based IC in a single overmolded design, with an additional molded lead-stabilizing bar for robust shipping and ease of assembly.

The IC's SolidSpeed Digital Architecture offers intelligent algorithms capable of maintaining stable operation during dynamic air gap movements. The sophisticated digital controller provides highly accurate speed detection and rotational direction detection ideal for ABS applications.

Integrated diagnostics are used to detect an IC failure impacting output protocol accuracy, providing ASIL B compliance. The IC includes built-in EEPROM scratch memory available for device traceability throughout sensor module production.

The IC is offered in the UB package, which integrates the IC and a high temperature ceramic capacitor in a single overmolded SIP package for enhanced EMC performance.

The 2-pin SIP package is lead (Pb) free, with tin leadframe plating.

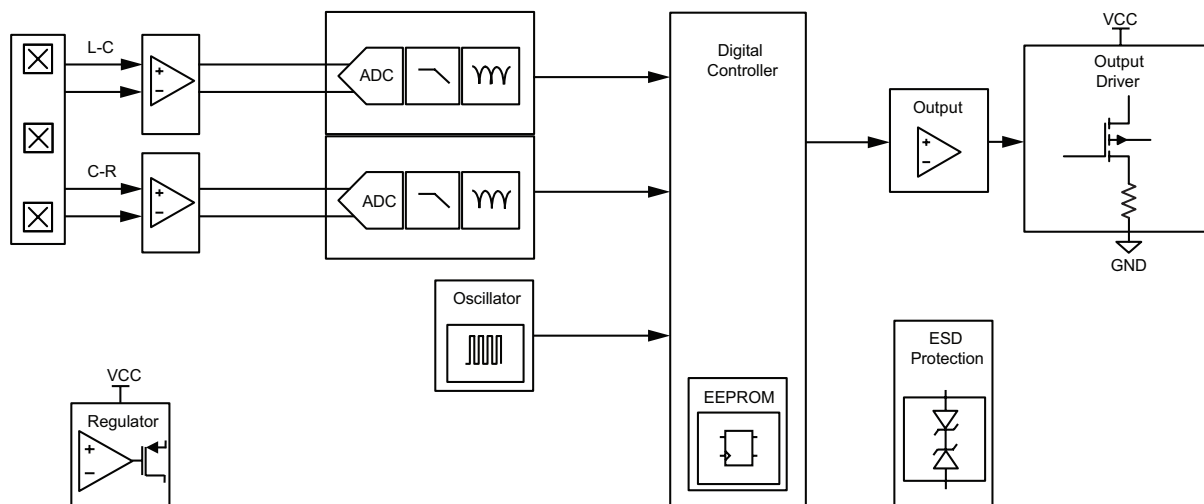

Functional Block Diagram

A19300

ASIL-Compliant Hall-Effect Wheel Speed Sensor IC with Speed and Direction Output

SELECTION GUIDE*

Part Number	Packing
A19300LUBATN-FWPE-A	Tape and reel, 4000 pieces per reel
A19300LUBATN-RWPE-A	Tape and reel, 4000 pieces per reel
A19300LUBATN-FWPE	Tape and reel, 4000 pieces per reel
A19300LUBATN-RWPE	Tape and reel, 4000 pieces per reel



*Not all combinations are available. Contact Allegro sales for availability and pricing of custom programming options.

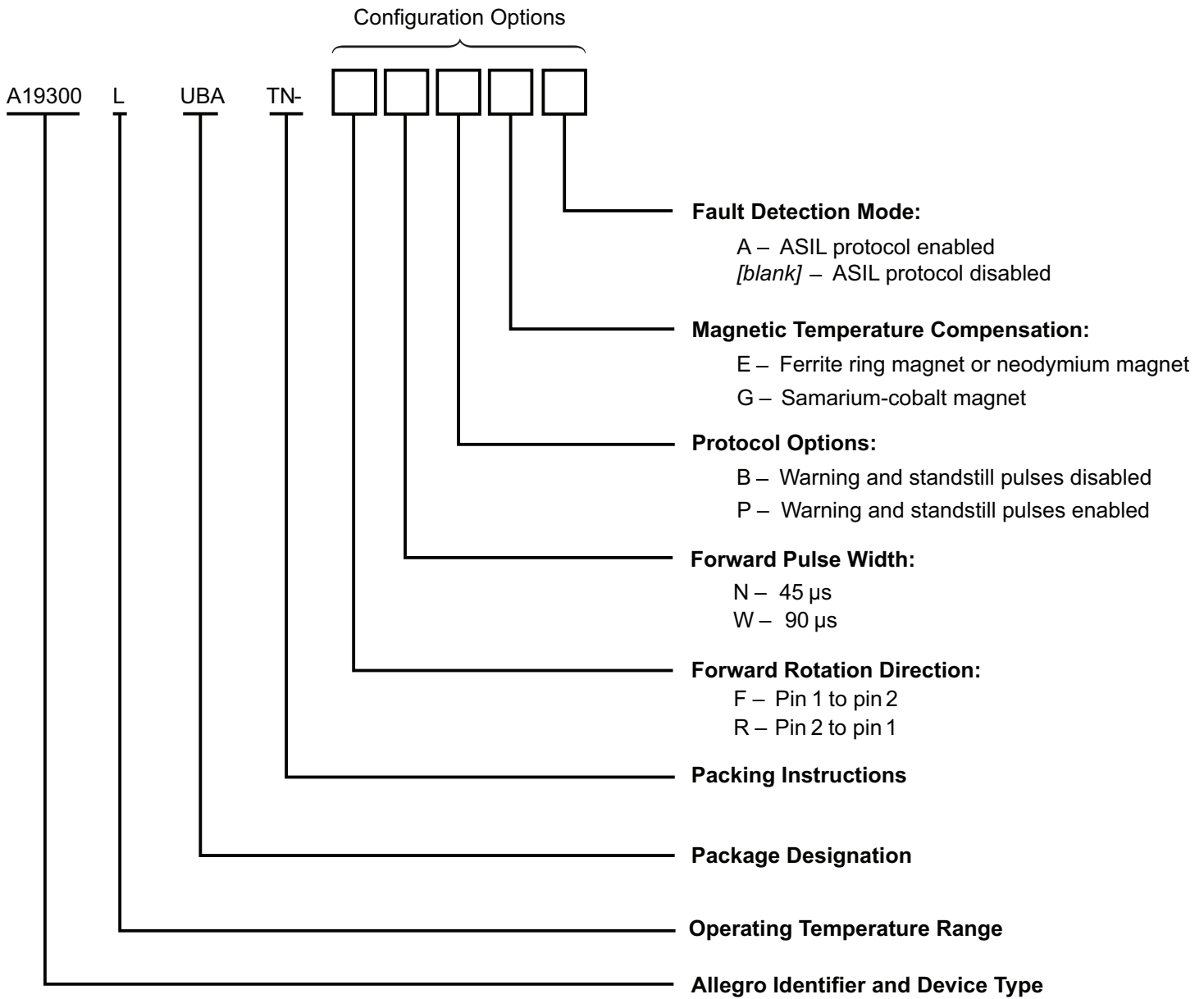

SPECIFICATIONS

ABSOLUTE MAXIMUM RATINGS

Characteristic	Symbol	Notes	Rating	Unit
Supply Voltage	V_{CC}	Refer to Power Derating section; potential between pin 1 and pin 2	28	V
Reverse Supply Voltage	V_{RCC}		-18	V
Operating Ambient Temperature	T_A		-40 to 150	°C
Maximum Junction Temperature	$T_{J(max)}$		165	°C
Storage Temperature	T_{stg}		-65 to 170	°C

INTERNAL DISCRETE CAPACITOR RATINGS

Characteristic	Symbol	Test Conditions	Value (Typ.)	Unit
Nominal Capacitance	C_{SUPPLY}	Connected between pin 1 and pin 2 (refer to Figure 1)	2.2	nF

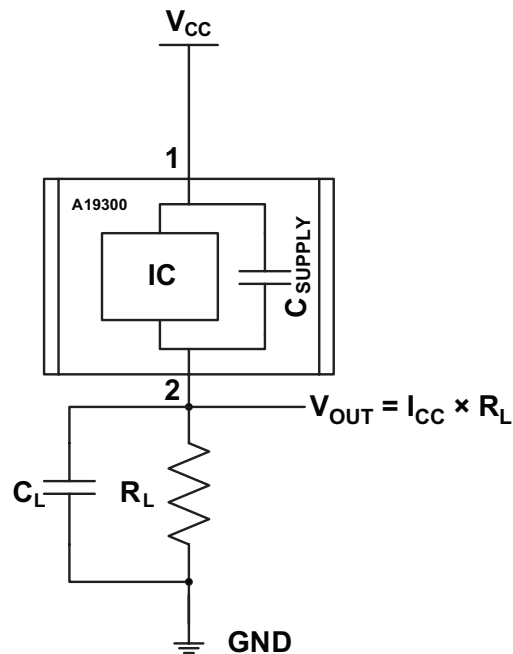
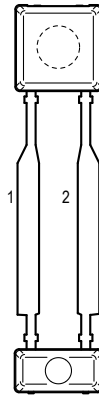

Figure 1: Typical Application Circuit

PINOUT DIAGRAM AND TERMINAL LIST**UB Package, 2-Pin SIP Pinout Diagram****Terminal List Table**

Name	Number	Function
VCC	1	Supply Voltage
GND	2	Ground

OPERATING CHARACTERISTICS: Valid throughout full operating and temperature ranges, unless otherwise specified

Characteristic	Symbol	Test Conditions	Min.	Typ. ^[1]	Max.	Unit
ELECTRICAL CHARACTERISTICS						
Supply Voltage ^[2]	V_{CC}	Potential between pin 1 and pin 2	4	–	24	V
Undervoltage Lockout	$V_{CC(UV)}$	$V_{CC} 0\text{ V} \rightarrow 5\text{ V}$ or $5\text{ V} \rightarrow 0\text{ V}$	–	3.6	3.95	V
Reverse Supply Current ^[3]	I_{RCC}	$V_{CC} = V_{RCC(max)}$	–10	–	–	mA
Supply Zener Clamp Voltage	$V_{Zsupply}$	$I_{CC} = 11.4\text{ mA}$, $T_A = 25^\circ\text{C}$, potential between pin 1 and pin 2	28	–	–	V
Supply Current	$I_{CC(LOW)}$	Low-current state	5.9	7	8.4	mA
	$I_{CC(HIGH)}$	High-current state	12	14	16	mA
Supply Current Ratio ^[4]	$I_{CC(HIGH)} / I_{CC(LOW)}$	Measured as ratio of high current to low current (isothermal)	1.9	–	–	–
ASIL Safety Current	I_{RESET}	Refer to Figure 10	1.5	3.5	3.9	mA
ASIL Safety Current Time	t_{RESET}	Refer to Figure 10	5	–	–	ms
Output Rise/Fall Time	t_r, t_f	Voltage measured at terminal 2 in Figure 1, $R_L = 100\ \Omega$, $C_L = 10\text{ pF}$, measured between 10% and 90% of $I_{CC(LOW)}$ and $I_{CC(HIGH)}$ ^[5]	0	–	1.5	μs
POWER-ON CHARACTERISTICS						
Power-On State	POS	$V_{CC} > V_{CC(min)}$, as connected in Figure 1	$I_{CC(LOW)}$			mA
Power-On Time ^[6]	t_{PO}	$V_{CC} > V_{CC(min)}$, as connected in Figure 1	–	0.25	1	ms
OUTPUT PULSE CHARACTERISTICS, PULSE PROTOCOL ^[6]						
Pulse Width Off Time	$t_{W(PRE)}$	Refer to Figure 8	38	45	52	μs
Forward Pulse Width	$t_{W(FWD)}$	-xNxx variant	38	45	52	μs
		-xWxx variant	76	90	104	μs
Reverse Pulse Width	$t_{W(REV)}$	-xNxx and -xWxx variant	153	180	207	μs
Warning Pulse Width	$t_{W(WARN)}$	-xxPx variant	38	45	52	μs
Standstill Pulse Width	$t_{W(STILL)}$	-xxPx variant	1232	1440	1656	μs
Standstill Period	t_{STOP}	-xxPx variant	590	737	848	ms

Continued on next page...

OPERATING CHARACTERISTICS (continued): Valid throughout full operating and temperature ranges, unless otherwise specified

Characteristic	Symbol	Test Conditions	Min.	Typ. ^[1]	Max.	Unit
OPERATING CHARACTERISTICS AND PERFORMANCE						
Operating Frequency, Forward Pulses ^[8]	f_{FWD}	-xNxx variant	0	–	5	kHz
		-xWxx variant	0	–	3.9	kHz
Operating Frequency, Reverse Pulses ^[8]	f_{REV}	-xNxx and -xWxx variant	0	–	2.4	kHz
Operating Frequency, Warning Pulses	f_{WARN}	-xxPx variant	0	–	5	kHz
Operating Differential Magnetic Input ^[9]	$B_{DIFF(pk-pk)}$	Peak-to-peak of differential magnetic input	20	–	–	G
Operating Differential Magnetic Range ^[9]	B_{DIFF}	Refer to Figure 5	–700	–	700	G
Air Gap Warning Level	B_{WARN}	Signal amplitude that engages warning pulses (-xxPx variant)	–	24	–	G
Operating Magnetic Input Signal Variation	$\Delta B_{DIFF(pk-pk)}$	Bounded amplitude ratio within T_{WINDOW} ^[10] ; no missed output transitions or flat line condition; possible incorrect direction information; see Figure 3 and Figure 4	0.4	–	–	–
Operating Magnetic Input Signal Window	T_{WINDOW}	Rolling window where $\Delta B_{DIFF(pk-pk)}$ cannot exceed bounded ratio; see Figure 3 and Figure 4	$4 \times T_{CYCLE}$	–	–	–
Calibration Period	T_{CAL}	Period between power-on and valid speed and correct direction output ($f \leq 200$ Hz)	–	–	$1.5 \times T_{CYCLE}$	–
Operate Point	B_{OP}	% of peak-to-peak IC-processed signal	–	60	–	%
Release Point	B_{RP}	% of peak-to-peak IC-processed signal	–	40	–	%
Switch Point Separation	$B_{DIFF(SP-SEP)}$	Required amount of amplitude separated between channels at each B_{OP} and B_{RP} occurrence and channels must be in phase (refer to Figure 6)	20	–	–	%pk-pk
THERMAL CHARACTERISTICS						
Magnetic Temperature Coefficient ^[11]	TC	Based on ferrite ring magnet and neodymium magnet (-xxxE Variant)	–	0.16	–	%/°C
		Based on SmCo magnet (-xxxG variant)	–	0.04	–	%/°C

^[1] Typical values are at $T_A = 25^\circ\text{C}$ and $V_{CC} = 12\text{ V}$. Performance may vary for individual units, within the specified maximum and minimum limits.

^[2] Maximum voltage must be adjusted for power dissipation and junction temperature; see representative for Power Derating discussions.

^[3] Negative current is defined as conventional current coming out of (sourced from) the specified device terminal.

^[4] Supply current ratio is taken as a mean value of $I_{CC(HIGH)} / I_{CC(LOW)}$.

^[5] Output Rise/Fall Time specification is guaranteed by design.

^[6] Time between power-on to I_{CC} stabilizing. Transitions prior to t_{PO} should be ignored.

^[7] Pulse width measured at threshold of $(I_{CC(HIGH)} + I_{CC(LOW)}) / 2$.

^[8] These frequency ranges are based on valid pulse width generation with each pulse width preceding with a $t_{W(PRE)(MAX)}$. Frequency is based on B_{DIFF} frequency.

^[9] Differential magnetic field is measured for Channel A (E1-E2) and Channel B (E2-E3) independently. Refer to Figure 5. Each channel's differential magnetic field is measured between two Hall elements spaced by 1.5 mm. Magnetic field is measured orthogonally to the front of the package. Refer to UB package drawing.

^[10] Symmetrical signal variation is defined as the largest amplitude ratio from B_n to $B_n + T_{WINDOW}$. Signal variation may occur continuously while B_{DIFF} remains in the operating magnetic range.

^[11] Magnetic encoders decrease in magnetic strength with rising temperature. The device temperature coefficient compensates, maintaining the $B_{DIFF(pk-pk)}$ requirement.

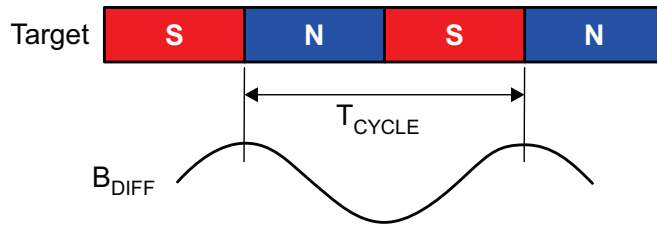

B_{DIFF} = Differential Input Signal; the differential magnetic flux sensed by the sensor

T_{CYCLE} = Target Cycle; the amount of rotation that moves one tooth (or north pole) and one valley (or south pole) across the sensor

Figure 2: Definition of T_{CYCLE}

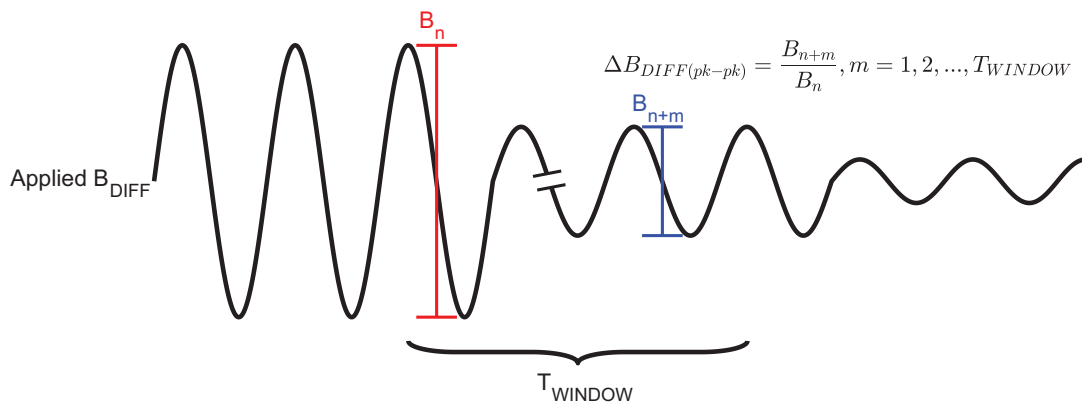

Figure 3: Single Period-to-Period Variation

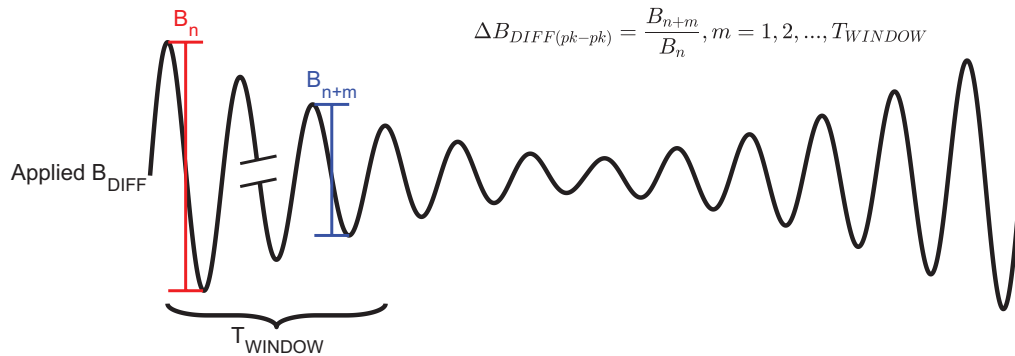

Figure 4: Repeated Period-to-Period Variation

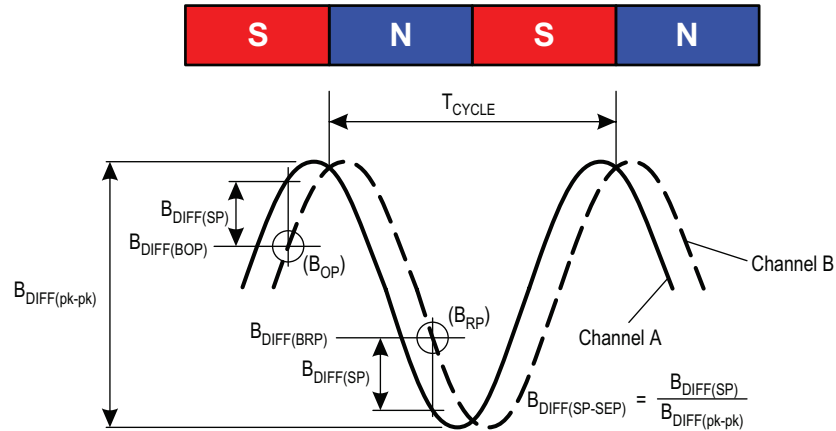

Figure 6: Definition of Switch Point Separation

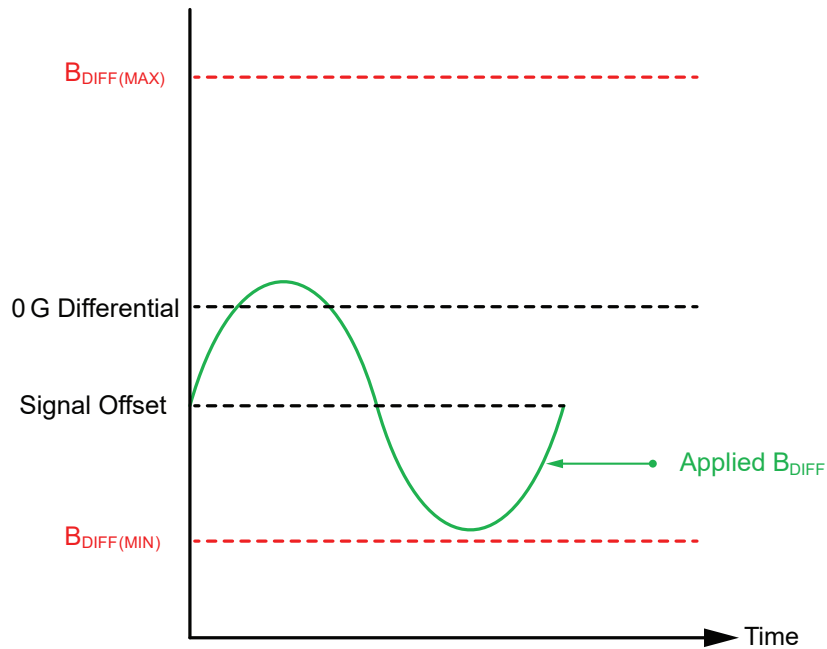

Figure 5: Input Signal Definition

THERMAL CHARACTERISTICS

Characteristic	Symbol	Test Conditions*	Value	Unit
Package Thermal Resistance	$R_{\theta JA}$	Single-layer PCB with copper limited to solder pads	213	°C/W

*Additional thermal information is available on the Allegro website.

Power Derating Curve

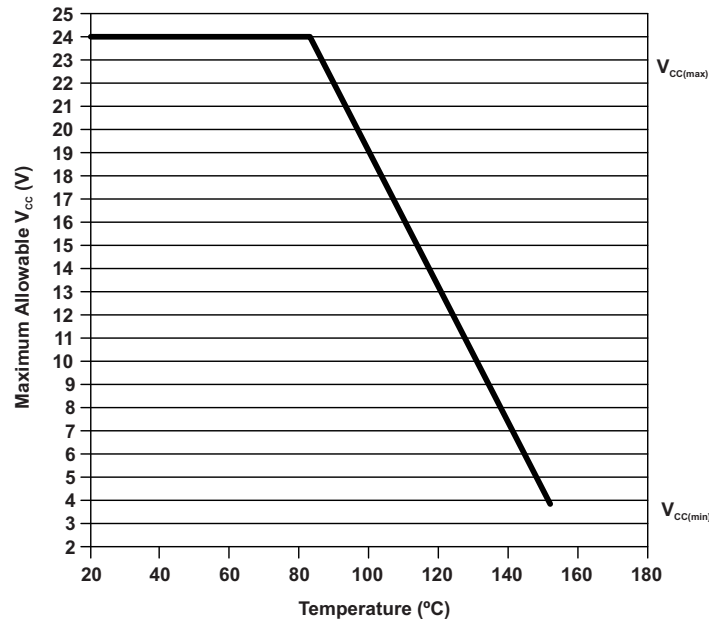

Power Dissipation versus Ambient Temperature

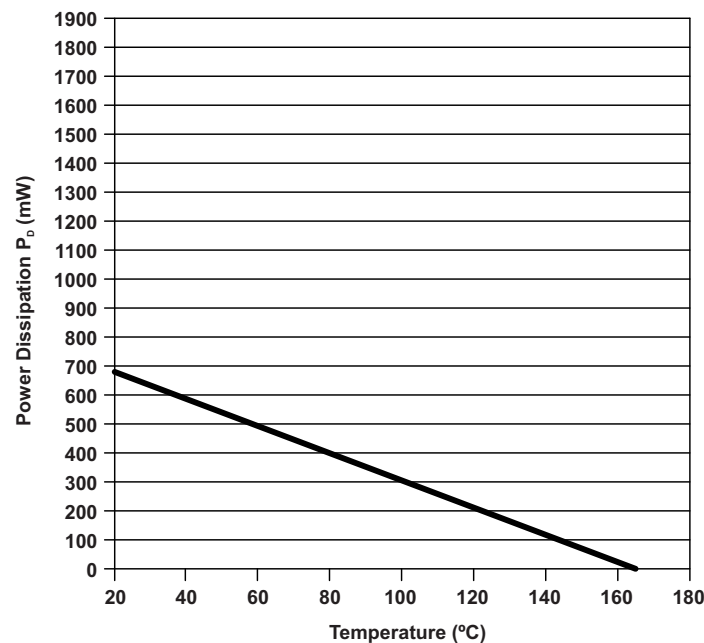

FUNCTIONAL DESCRIPTION

The A19300 sensor IC contains a single-chip Hall-effect circuit that supports three Hall elements. These elements are used in differential pairs to provide electrical signals containing information regarding edge position and direction of target rotation. The A19300 is intended for use with ring magnet targets, or, when back-biased with an appropriate magnet, with ferrous targets. The IC detects the peaks of the magnetic signals and sets dynamic thresholds based on these detected signals.

Data Protocol Description

When a target passes in front of the device (opposite the branded face of the package case), the A19300 generates an output pulse for each magnetic pole or for each tooth and each valley of the target. Speed information is provided by the output pulse rate, while direction of target rotation is provided by the duration of the output pulses.

FORWARD ROTATION

For the -F variant, when the target is rotating such that a target feature passes from pin 1 to pin 2, this is referred to as forward rotation. This direction of rotation is indicated on the output by a $t_{w(FWD)}$ pulse width. For the -R variant, forward direction is indicated for target rotation from pin 2 to 1 (refer to Figure 7).

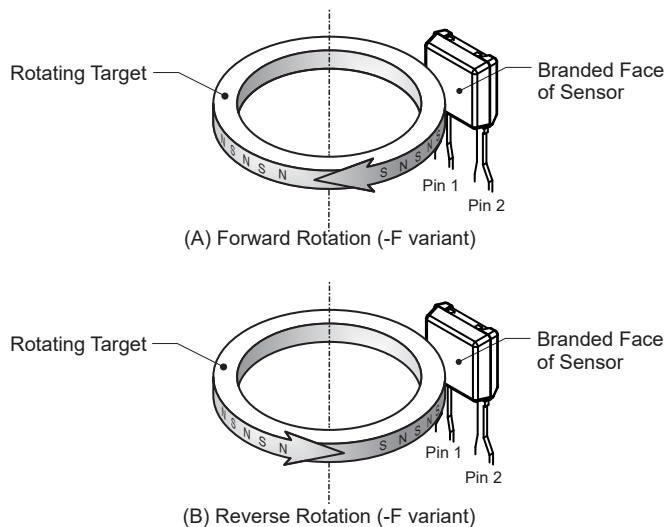

Figure 7: Target Orientation Relative to Device (ring magnet shown).

REVERSE ROTATION

For the -F variant, when the target is rotating such that a target feature passes from pin 2 to pin 1, this is referred to as reverse rotation. This direction of rotation is indicated on the output by a $t_{w(REV)}$ pulse width. For the -R variant, reverse direction is indicated for target rotation from pin 1 to 2.

Output edges are triggered by B_{DIFF} transitions through the switch points. On a crossing, the output is first set to $I_{CC(Low)}$ for a duration of $t_{w(PRE)}$, after which the output pulse of $I_{CC(HIGH)}$ is present for $t_{w(FWD)}$, $t_{w(REV)}$, or $t_{w(WARN)}$. The IC is always capable of properly detecting input signals up to the defined operating frequency. The $t_{w(PRE)}$ period is dominant, thus always providing rising output edge, but at high frequencies potentially truncating the $I_{CC(HIGH)}$ duration.

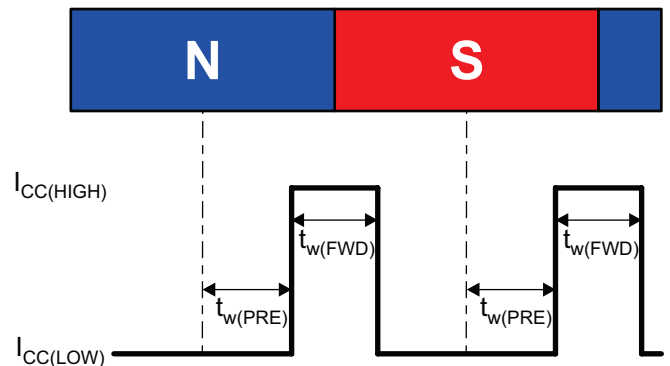
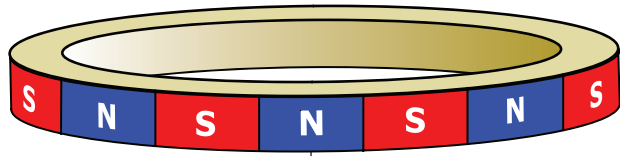
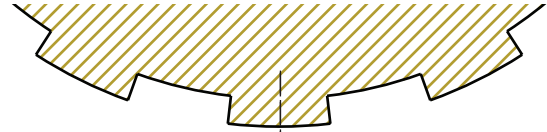
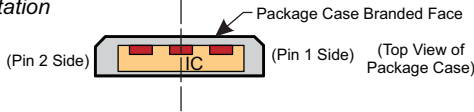

Figure 8: Output Timing Example



Device Orientation to Target



Device Orientation to Target

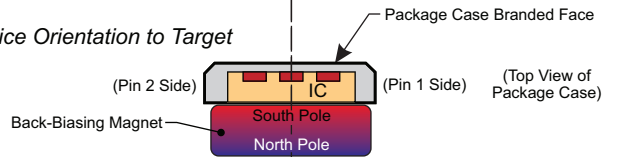

Mechanical Position (Target moves past device pin 1 to pin 2)

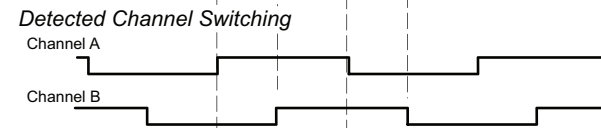
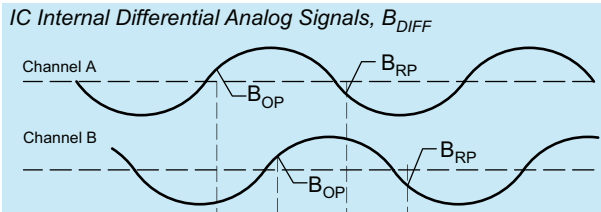
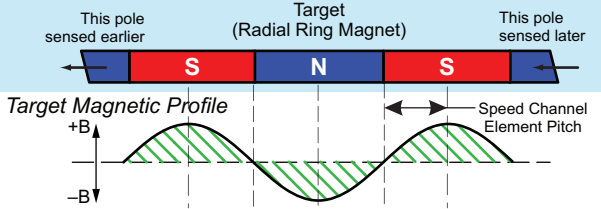

Mechanical Position (Target moves past device pin 1 to pin 2)

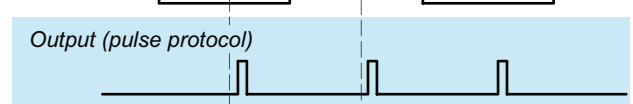
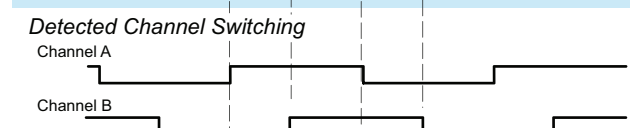
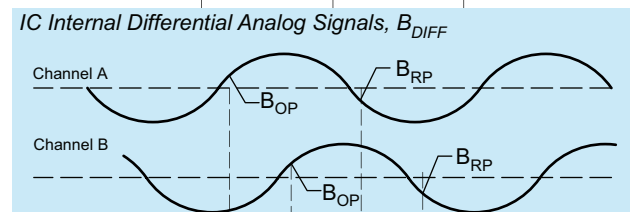
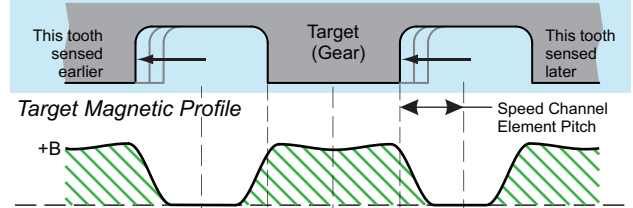

Figure 9: Basic Operation

Channel A or Channel B can be used as the output switching channel. This is determined on startup by the first channel that switches. The non-switching channel is used for direction detection.

ASIL Safe State Output Protocol

The A19300 sensor IC contains diagnostic circuitry that will continuously monitor occurrences of failure defects within the IC. Refer to Figure 10 for the output protocol of the ASIL safe state after an internal defect has been detected. Error Protocol will result from faults which cause incorrect signal transmission (i.e., too few or too many output pulses).

Note: If a fault exists continuously, the device will stay in permanent safe state. Refer to the A19300 Safety Manual for additional details on the ASIL Safe State Output Protocol.

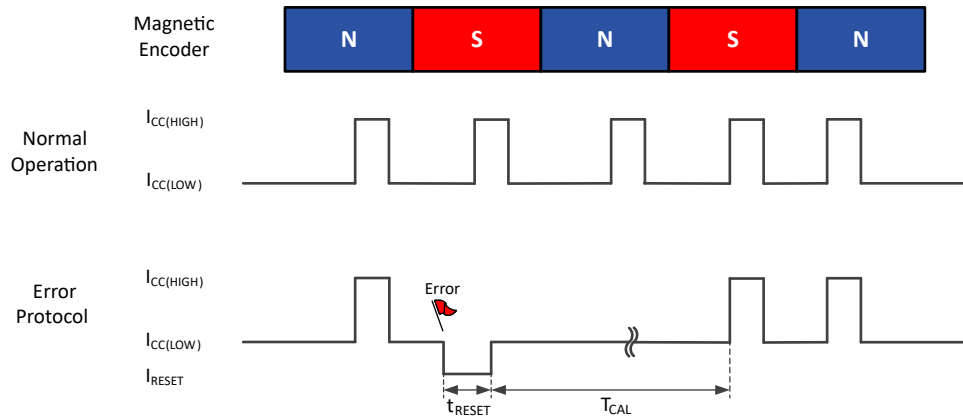

Figure 10: Output Protocol (ASIL Safe State)

Calibration and Direction Validation

When power is applied to the A19300, the built-in algorithm performs an initialization routine. For a short period after power-on, the device calibrates itself and determines the direction of target rotation. Once the calibration routine is complete, the A19300 will transmit accurate speed and direction information.

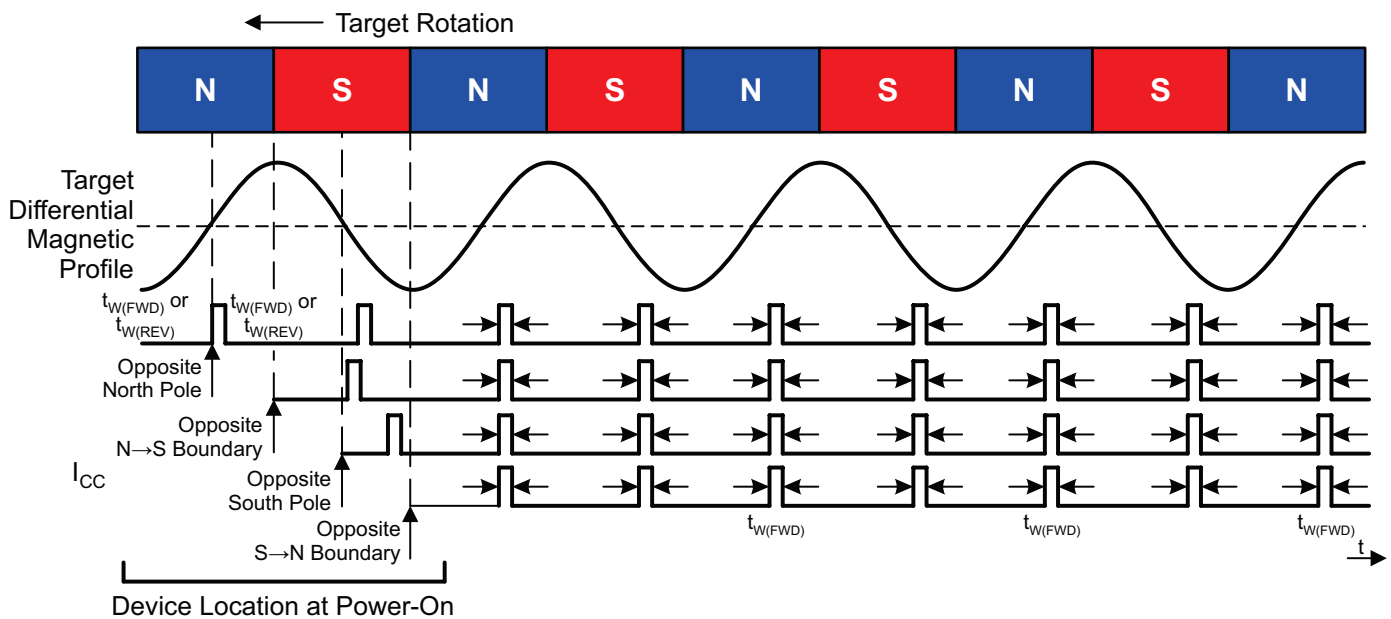

Figure 11: Calibration Behavior (-xxBx Variant)

Direction Changes, Vibrations, and Anomalous Events

During normal operation, the A19300 will be exposed to changes in the direction of target rotation (Figure 12), vibrations of the target (Figure 13), and anomalous events such as sudden air gap changes.

During calibration, output pulses with direction information are immediately transmitted to the output. Depending on target design, air gap, and the phase of the target, direction may be momentarily incorrect. Following a direction change in running mode, direction changes are immediately transmitted to the output. Depending on target design and the phase of the target, direction may be fleetingly incorrect.

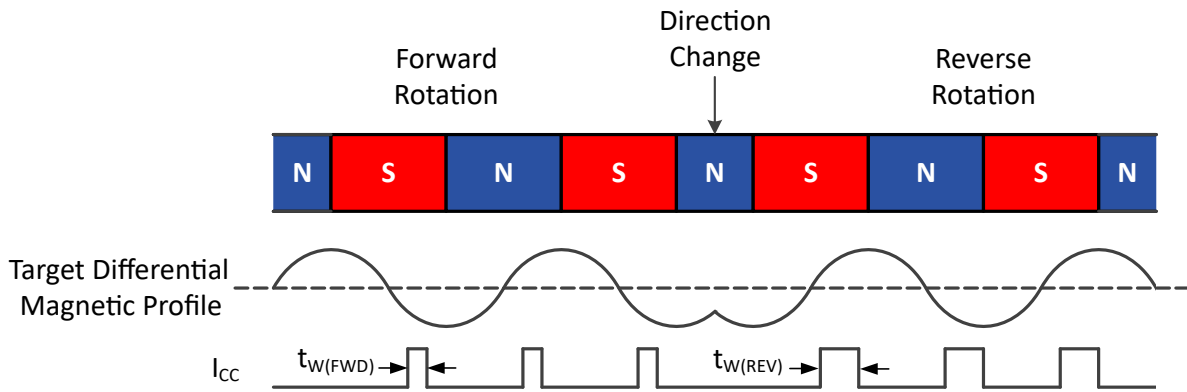

Figure 12: Direction Change Behavior

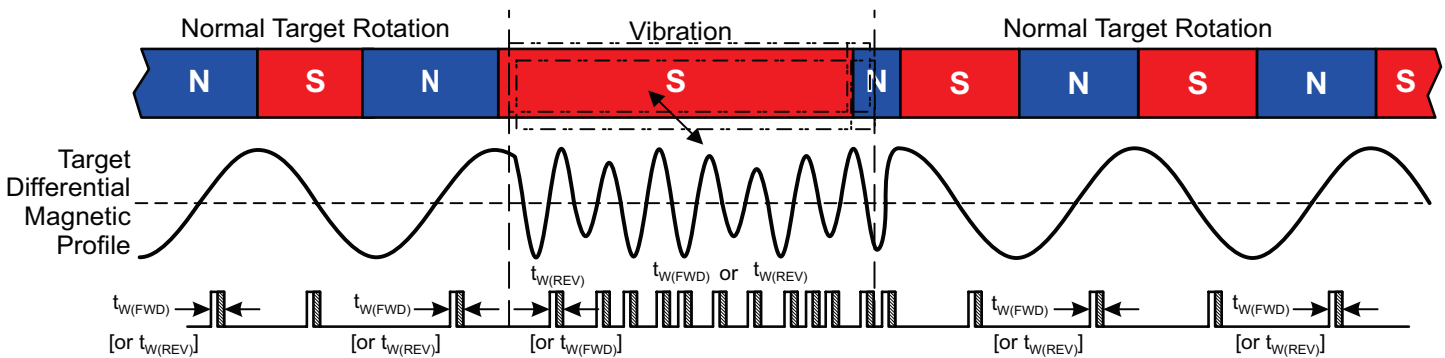

Figure 13: Vibration Behavior

POWER DERATING

The device must be operated below the maximum junction temperature of the device ($T_{J(max)}$). Under certain combinations of peak conditions, reliable operation may require derating supplied power or improving the heat dissipation properties of the application. This section presents a procedure for correlating factors affecting operating T_J . (Thermal data is also available on the Allegro MicroSystems website.)

The Package Thermal Resistance ($R_{\theta JA}$) is a figure of merit summarizing the ability of the application and the device to dissipate heat from the junction (die), through all paths to the ambient air. Its primary component is the Effective Thermal Conductivity (K) of the printed circuit board, including adjacent devices and traces. Radiation from the die through the device case ($R_{\theta JC}$) is a relatively small component of $R_{\theta JA}$. Ambient air temperature (T_A) and air motion are significant external factors, damped by overmolding.

The effect of varying power levels (Power Dissipation or P_D), can be estimated. The following formulas represent the fundamental relationships used to estimate T_J , at P_D .

$$P_D = V_{IN} \times I_{IN} \quad (1)$$

$$\Delta T = P_D \times R_{\theta JA} \quad (2)$$

$$T_J = T_A + \Delta T \quad (3)$$

For example, given common conditions such as: $T_A = 25^\circ\text{C}$, $V_{CC} = 12\text{ V}$, $I_{CC} = 7.15\text{ mA}$, and $R_{\theta JA} = 213^\circ\text{C/W}$, then:

$$P_D = V_{CC} \times I_{CC} = 12\text{ V} \times 7.15\text{ mA} = 85.8\text{ mW}$$

$$\Delta T = P_D \times R_{\theta JA} = 85.8\text{ mW} \times 213^\circ\text{C/W} = 18.3^\circ\text{C}$$

$$T_J = T_A + \Delta T = 25^\circ\text{C} + 18.3^\circ\text{C} = 43.3^\circ\text{C}$$

A worst-case estimate, $P_{D(max)}$, represents the maximum allowable power level ($V_{CC(max)}$, $I_{CC(max)}$), without exceeding $T_{J(max)}$, at a selected $R_{\theta JA}$ and T_A .

Example: Reliability for V_{CC} at $T_A = 150^\circ\text{C}$, package UB, using minimum-K PCB.

Observe the worst-case ratings for the device, specifically: $R_{\theta JA} = 213^\circ\text{C/W}$, $T_{J(max)} = 165^\circ\text{C}$, $V_{CC(max)} = 24\text{ V}$, and $I_{CC(AVG)} = 14.8\text{ mA}$. $I_{CC(AVG)}$ is computed using $I_{CC(HIGH)(max)}$ and $I_{CC(LOW)(max)}$, with a duty cycle of 84% computed from $t_{w(REV)(max)}$ on-time and $t_{w(PRE)(min)}$ off-time (pulse width protocol).

Calculate the maximum allowable power level ($P_{D(max)}$). First, invert equation 3:

$$\Delta T_{max} = T_{J(max)} - T_A = 165^\circ\text{C} - 150^\circ\text{C} = 15^\circ\text{C}$$

This provides the allowable increase to T_J resulting from internal power dissipation. Then, invert equation 2:

$$P_{D(max)} = \Delta T_{max} \div R_{\theta JA} = 15^\circ\text{C} \div 213^\circ\text{C/W} = 70.4\text{ mW}$$

Finally, invert equation 1 with respect to voltage:

$$V_{CC(est)} = P_{D(max)} \div I_{CC(AVG)} = 70.4\text{ mW} \div 14.8\text{ mA} = 4.8\text{ V}$$

The result indicates that, at T_A , the application and device can dissipate adequate amounts of heat at voltages $\leq V_{CC(est)}$.

Compare $V_{CC(est)}$ to $V_{CC(max)}$. If $V_{CC(est)} \leq V_{CC(max)}$, then reliable operation between $V_{CC(est)}$ and $V_{CC(max)}$ requires enhanced $R_{\theta JA}$. If $V_{CC(est)} \geq V_{CC(max)}$, then operation between $V_{CC(est)}$ and $V_{CC(max)}$ is reliable under these conditions.

PACKAGE OUTLINE DRAWING

For Reference Only – Not for Tooling Use

(Reference DWG-0000408, Rev. 4)

Dimensions in millimeters – NOT TO SCALE

Exact case and lead configuration at supplier discretion within limits shown

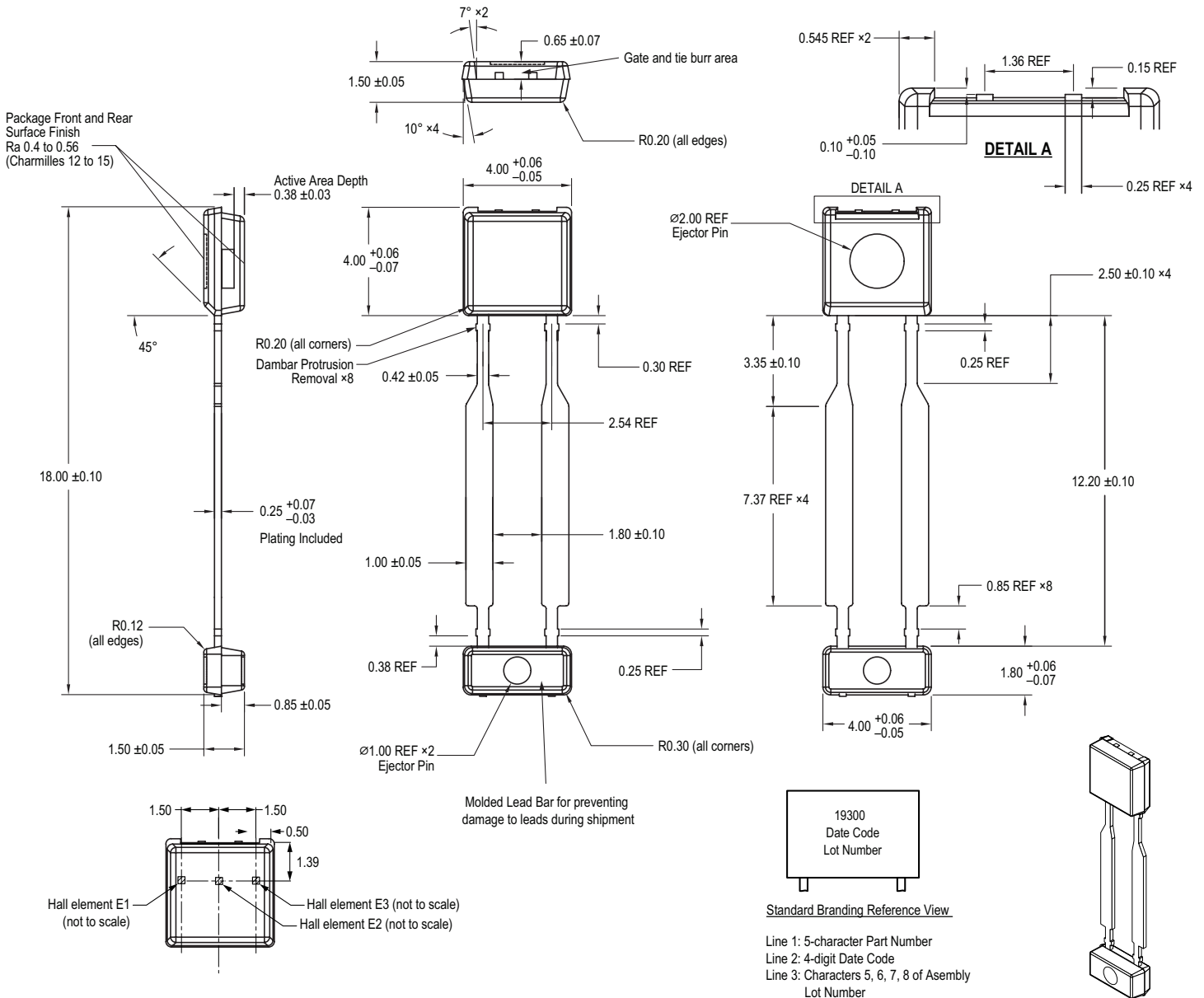

Figure 14: Package UB, 2-Pin SIP