

High-Performance GMR AK Protocol Wheel Speed and Direction Sensor IC

FEATURES AND BENEFITS

- **GMR** elements provide highly repeatable, ultra-low jitter signal for iTPMS and ADAS applications
- **Wide Air Gap** capability eases mechanical mounting tolerance requirements to enable lower cost
- **AK Protocol** compliant output with air gap information
- **SolidSpeed Digital Architecture** provides robust, adaptive performance with advanced algorithms
- **ISO 26262 ASIL B(D)** with integrated diagnostics and certified safety design process



PACKAGE:



2-Pin SIP
(suffix UB)

Not to scale

DESCRIPTION

The A19351 is a giant magnetoresistance (GMR) magnetic sensor integrated circuit (IC) designed to measure ring magnets used in automotive braking systems, to provide wheel speed and direction information. The IC fully integrates sensing elements, voltage regulators, analog-to-digital converters, and a digital controller to adaptively measure the magnetic signal and provide a robust, low-jitter AK Protocol output across the two-wire interface.

The A19351 features Allegro's SolidSpeed Digital Architecture, the latest mixed-signal speed sensor architecture for highly adaptive performance that provides the widest dynamic range of operating air gap and compensates for temperature drift effects. Flexibility is passed to the system integrator, enabling looser mechanical constraints with a wide operating air gap.

The A19351 was developed in accordance with ISO 26262 as a hardware safety element out of context with ASIL B(D) capability for use in automotive safety-related systems when integrated and used in the manner prescribed in the applicable safety manual and datasheet.

The A19351 is provided in a 2-pin SIP package (suffix UB) that is lead (Pb) free, with tin leadframe plating. The UB package includes an IC and protection capacitor integrated into a single overmolded package, with an additional molded lead-stabilizing bar for robust shipping and ease of assembly.

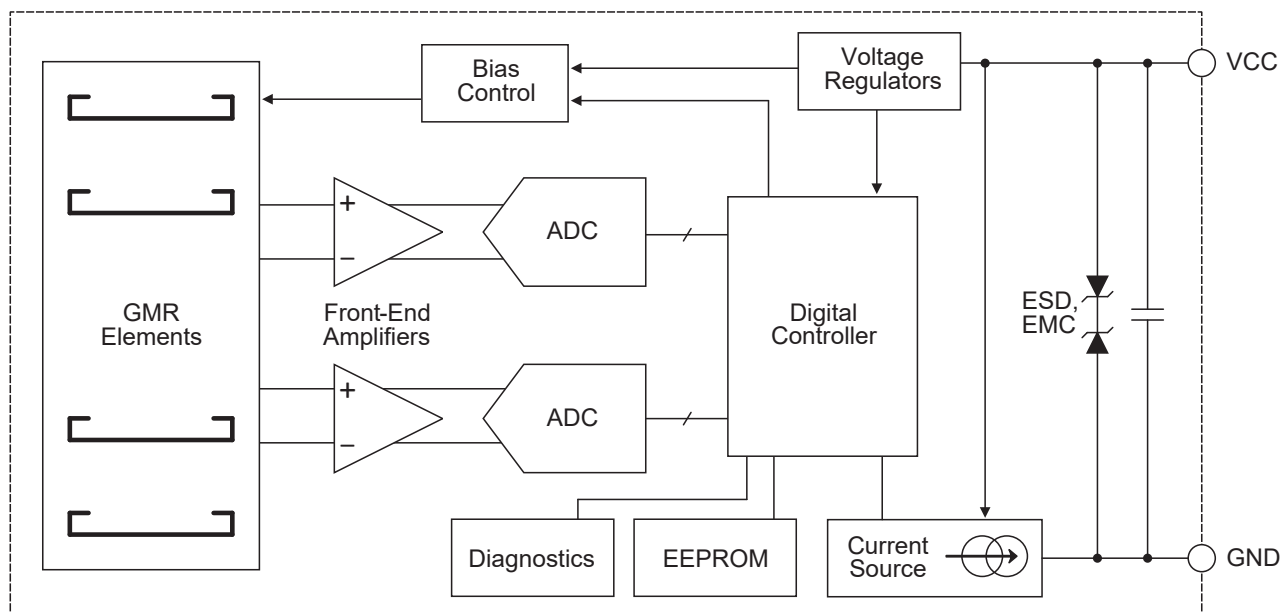

Figure 1: Functional Block Diagram

SELECTION GUIDE*

Part Number	Packing
A19351PUBATN-F-A	Tape and Reel, 4000 pieces per reel
A19351PUBATN-R-A	



* Not all combinations are available. Contact Allegro sales for availability and pricing of custom programming options.

Programming Options

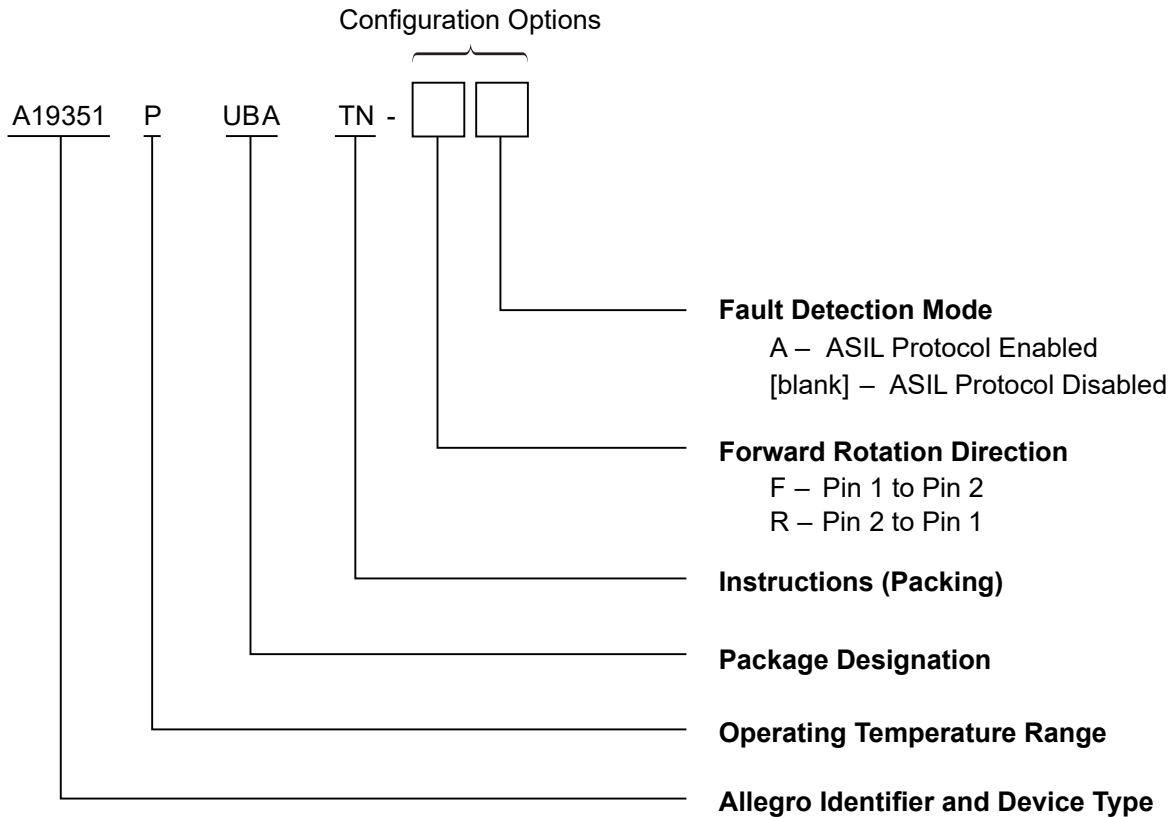

SPECIFICATIONS

ABSOLUTE MAXIMUM RATINGS

Characteristic	Symbol	Notes	Rating	Unit
Supply Voltage	V_{CC}	Refer to Power Derating section; potential between pin 1 and pin 2	28	V
Reverse Supply Voltage	V_{RCC}		-16.5	V
Operating Ambient Temperature	T_A		-40 to 160	°C
Maximum Junction Temperature	$T_{J(MAX)}$		175	°C
Storage Temperature	T_{stg}		-65 to 170	°C
Applied Magnetic Flux Density	B	In any direction	500	G

INTERNAL DISCRETE CAPACITOR RATINGS

Characteristic	Symbol	Test Conditions	Value (typ.)	Unit
Nominal Capacitance	C_{SUPPLY}	Connected between pin 1 and pin 2 (refer to Figure 2)	2.2	nF

PINOUT DIAGRAM AND PINOUT LIST

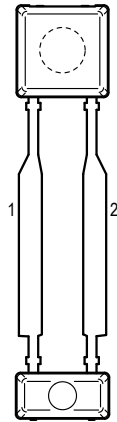

Package UB, 2-Pin SIP Pinout Diagram

Pinout List

Pin Name	Pin Number	Function
VCC	1	Supply Voltage
GND	2	Ground

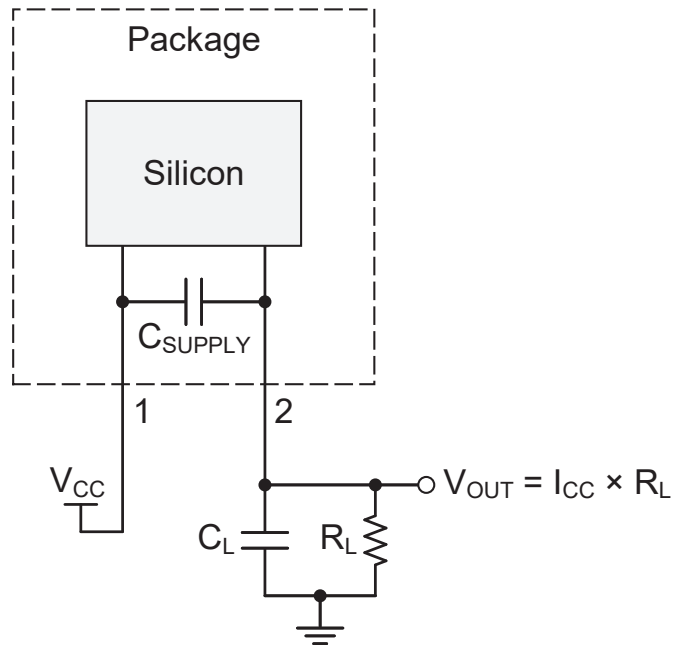

Figure 2: Typical Application Circuit

OPERATING CHARACTERISTICS: Valid throughout full operating voltage and temperature ranges, unless otherwise specified

Characteristic	Symbol	Test Conditions	Min.	Typ. [1]	Max.	Unit
ELECTRICAL CHARACTERISTICS						
Supply Voltage [2]	V_{CC}	Potential between pin 1 and pin 2	5.5	–	24	V
Undervoltage Lockout	$V_{CC(OFF)}$	V_{CC} switch off	–	–	3.5	V
UVLO Hysteresis	$V_{HYS(AK)}$		1.6	–	2	V
Reverse Supply Current [3]	I_{RCC}	$V_{CC} = V_{RCC(MAX)}$	–10	–	–	mA
Supply Zener Clamp Voltage	$V_{Zsupply}$	$I_{CC} = I_{CC(MAX)} + 3 \text{ mA}$, $T_A = 25^\circ\text{C}$	28	–	–	V
Supply Current	$I_{CC(LOW)}$	Low-current state	5.88	7	8.4	mA
	$I_{CC(MID)}$	Mid-current state	11.76	14	16.8	mA
	$I_{CC(HIGH)}$	High-current state	23.52	28	33.6	mA
Supply Current Ratio [4]		$I_{CC(MID)} / I_{CC(LOW)}$	1.9	–	–	–
		$I_{CC(HIGH)} / I_{CC(LOW)}$	3.7	–	–	–
Fault Current	I_{FAULT}	Refer to Figure 11	1	–	3.8	mA
Fault Current Duration	$t_{W(FAULT)}$	Refer to Figure 11	4	–	7	ms
Output Rise, Fall Slew Rate	SR	$R_L = 50 \Omega$, $C_L = 10 \text{ pF}$, measured between 10% and 90% of signal	8	–	28	mA/ μs
POWER-ON CHARACTERISTICS						
Power-On State	POS	$V_{CC} > V_{CC(min)}$ as connected in Figure 1	$I_{CC(LOW)}$			mA
Power-On Time [5]	t_{PO}	$V_{CC} > V_{CC(min)}$ as connected in Figure 1	–	–	1	ms
Calibration Time	T_{FP}	Rotation after t_{PO} to first output event	–	–	1.5	T_{CYCLE}
	T_{DIR}	Rotation after t_{PO} to first output event with direction information	–	–	2.25	T_{CYCLE}
PERFORMANCE						
First Direction Pulse Output Following Vibration		Period between vibration ends and valid direction output	–	–	4	T_{CYCLE}
Vibration Suppression			–	–	1	T_{CYCLE}

[1] Typical values are at $T_A = 25^\circ\text{C}$ and $V_{CC} = 12 \text{ V}$. Performance may vary for individual units, within the specified maximum and minimum limits.

[2] Maximum voltage must be adjusted for power dissipation and junction temperature; see representative Power Derating section.

[3] Negative current is defined as conventional current coming out of (sourced from) the specified device terminal.

[4] Supply current ratios are taken with the mean values of $I_{CC(LOW)}$, $I_{CC(MID)}$, and $I_{CC(HIGH)}$.

[5] Time between power-on to I_{CC} stabilizing. Output transients prior to t_{PO} should be ignored.

Continued on the next page...

OPERATING CHARACTERISTICS (continued): Valid throughout full operating voltage and temperature ranges, unless otherwise specified

Characteristic	Symbol	Test Conditions	Min.	Typ. [1]	Max.	Unit
AK PROTOCOL OPTION						
Bit Width	t_p		40	50	60	μs
Standstill Period	t_{STOP}		105	150	195	ms
Air Gap Reserve Level	B_{LR}	Differential signal that engages AK LR bit	–	3.6	–	G
INPUT CHARACTERISTICS AND PERFORMANCE						
Operating Frequency [6]	f_{SIG}	Forward and reverse rotation; with AK bit truncation beginning at 1 kHz	0	–	4	kHz
Operating Differential Magnetic Input [7]	$B_{\text{DIFF(pk-pk)}}$	Peak-to-peak of differential magnetic input; see Figure 5	2.7	–	–	G
Operating Differential Magnetic Range	B_{DIFF}		–900	–	900	G
Allowable User-Induced Differential Offset	B_{SIGEXT}	External differential signal bias (DC), operating within specification	–40	–	40	G
Operating Magnetic Input Signal Variation	$\Delta B_{\text{DIFF(pk-pk)}}$	Bounded amplitude ratio within T_{WINDOW} [8]; no missed output transitions or flat line condition; possible incorrect direction information; see Figure 3 and Figure 4	0.6	–	–	–
Operating Magnetic Input Signal Window	T_{WINDOW}	Rolling window where $\Delta B_{\text{DIFF(pk-pk)}}$ cannot exceed bounded ratio; see Figure 3 and Figure 4	4	–	–	T_{CYCLE}
Operate Point	B_{OP}	% of peak-to-peak IC-processed signal	–	60	–	%
Release Point	B_{RP}	% of peak-to-peak IC-processed signal	–	40	–	%
Repeatability [9]	$\text{Err}_{\theta\text{E}}$	Constant air gap, temperature, and target speed. $B_{\text{DIFF(pk-pk)}} > 20$ G. Primary Pulses, percent of a T_{CYCLE} one sigma.	–	0.02	–	%
Switch Point Separation	$B_{\text{DIFF(SP-SEP)}}$	Required amount of amplitude separation between Channel A and Channel B at each B_{OP} and B_{RP} occurrence. Channels must be in phase; see Figure 6	20	–	–	%pk-pk
THERMAL CHARACTERISTICS						
Magnetic Temperature Coefficient [10]	TC	Valid for full temperature range based on ferrite	–	0.2	–	%/°C
Package Thermal Resistance	$R_{\theta\text{JA}}$	Single-layer PCB with copper limited to solder pads	–	213	–	°C/W

[6] Frequency is based on B_{DIFF} frequency.

[7] Differential magnetic field is measured for the Channel A (E1-E3) and Channel B (E2-E4). Each channel's differential magnetic field is measured between two GMR elements spaced by 1.9 mm. Magnetic field is measured in the B_y direction and the $|B_x|$ field needs to be less than 80 G (Refer to Figure 7).

[8] Symmetrical signal variation is defined as the largest amplitude ratio from B_n to $B_n + T_{\text{WINDOW}}$. Signal variation may occur continuously while B_{DIFF} remains in the operating magnetic range.

[9] Constant air gap ($B_{\text{DIFF(pk-pk)}} > 20$ G), temperature, and target speed. Sinusoidal input signal. Repeatability (i.e., jitter) is guaranteed by design and characterization only.

[10] Ring magnet decreases in magnetic strength with rising temperature, and the device compensates. Note that $B_{\text{DIFF(pk-pk)}}$ requirement is not influenced by this.

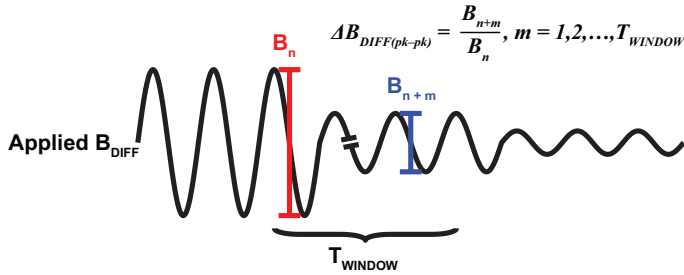

Figure 3: Single Period-to-Period Variation

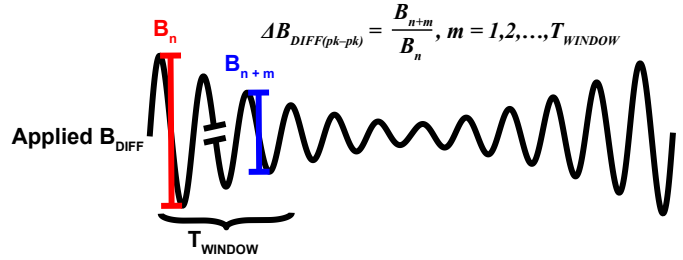

Figure 4: Repeated Period-to-Period Variation

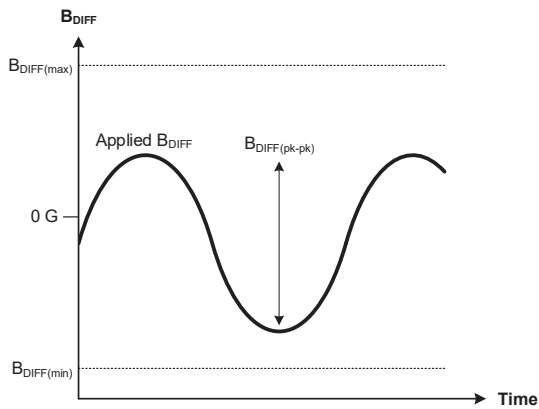

Figure 5: Input Signal Definition

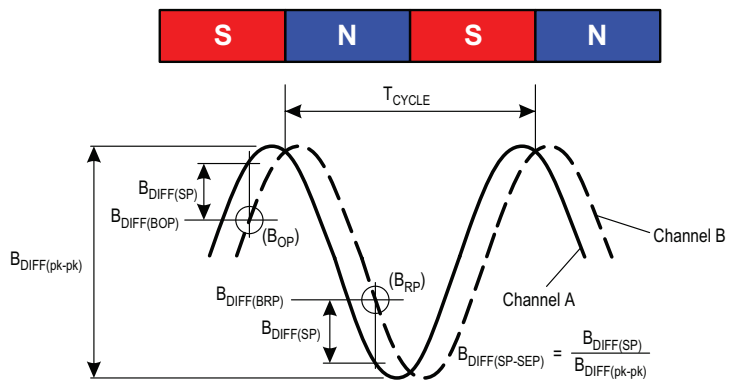

Figure 6: Definition of Switch Point Separation

FUNCTIONAL DESCRIPTION

The A19351 sensor IC contains a single-chip GMR circuit that uses spaced elements. These elements are used in differential pairs to provide electrical signals containing information regarding edge position and direction of rotation. The A19351 is intended for use with ring magnet targets as shown in Figure 8. The IC detects the peaks of the magnetic signals and sets dynamic thresholds based on these detected signals.

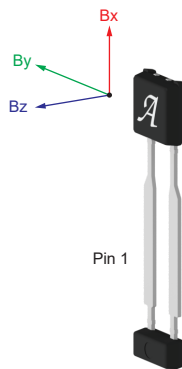

Figure 7: Package Orientation

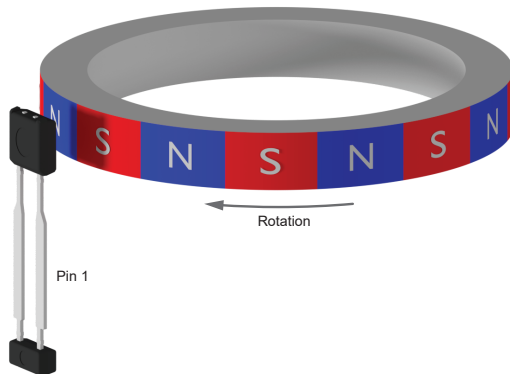

Figure 8: Target Orientation Relative to Device

Forward Rotation

For the -F variant, when the target is rotating such that a target feature passes from pin 1 to pin 2, this is referred to as forward rotation. For the -R variant, forward direction is indicated for target rotation from pin 2 to 1.

Reverse Rotation

For the -F variant, when the target is rotating such that a target feature passes from pin 2 to pin 1, this is referred to as reverse rotation. For the -R variant, reverse direction is indicated for target rotation from pin 1 to 2.

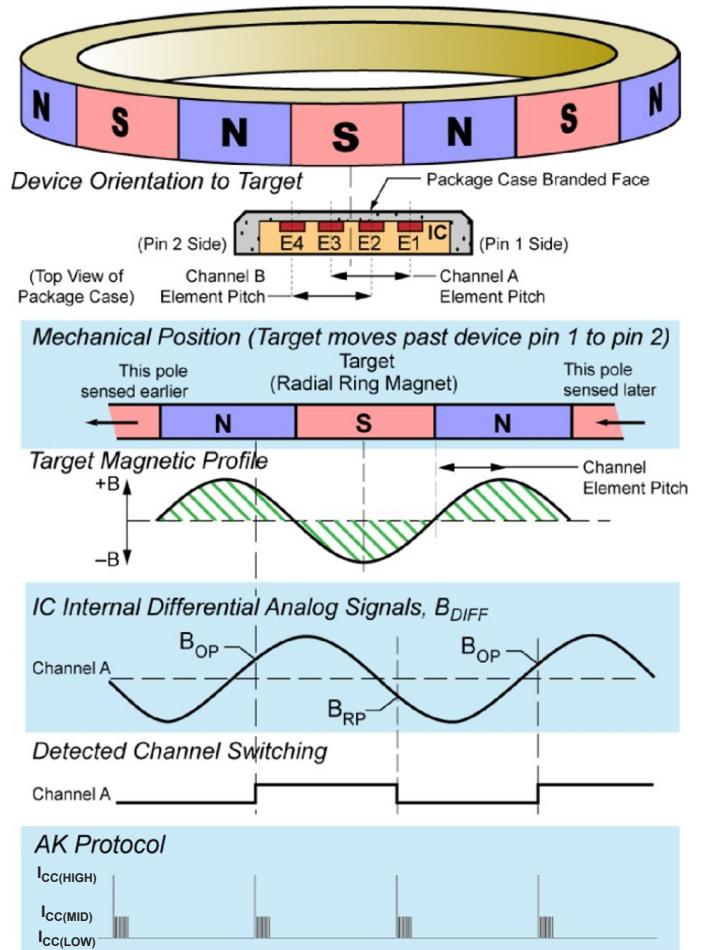

Figure 9: Basic Operation

AK Protocol Description

When a target passes in front of the device (opposite the branded face of the package case), the A19351 generates two output words for each magnetic pole-pair of the target. Speed information is provided by the speed pulse rate, and other information is directly communicated via the AK bits as described below.

Output words are triggered by B_{DIFF} transitions through two equidistant switch points. On a crossing, the speed pulse and relevant data are generated and transmitted. The IC is always capable

of properly detecting input signals up to the defined operating frequency. At frequencies beyond the operational frequency, the speed pulses will be present until the ASIL over-frequency limit asserts.

The A19351 will fulfill the requirements according to the AK Protocol specification “Requirement Specification for Standardized Interface for Wheel Speed Sensors with Additional Information ‘AK-Protokoll’” version 4.0 with some modifications as discussed in the sections that follow.

AK Bit Definitions

The AK word consists of 10 pulses: a single speed pulse, 8 data bits, and a single parity bit. The speed pulse and data bit definitions are described in Table 1.

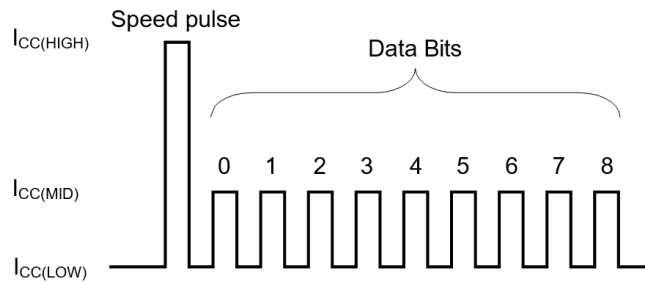

Figure 10: AK Protocol Message Format

Table 1: Speed Pulse and Data Bit Definitions

Bit Number	Field	Abbreviation	Coding	Post-Power-On Default Value
–	Speed Pulse	SP	$I_{CC(HIGH)}$ if speed pulse, $I_{CC(MID)}$ if standstill pulse	–
0	Air Gap Reserve	LR	1 if $B_{DIFF(pk-pk)} < B_{LR}$, 0 otherwise	0
1	Status Mode	M	1 if not in running mode, 0 otherwise	1
2	Unused	X	0 always	0
3	Direction Validity	GDR	1 if direction is valid, 0 otherwise	0
4	Direction	DR	1 if rotation direction is FWD, 0 if direction REV	0
5	Air Gap Indication (LSB)	LM0	LM LSB	0
6	Air Gap Indication	LM1	LM	0
7	Air Gap Indication (MSB)	LM2	LM MSB	0
8	Parity	P	Even Parity	1

LM Air Gap Table

Data bits [5:7] report the air gap indication. These bits give 8 air gap ranges with respect to the measured peak-to-peak magnetic field, $B_{DIFF(pk-pk)}$.

Table 2: LM Air Gap

LM2	LM1	LM0	$B_{DIFF(pk-pk)}$ Range (Typ.)
0	0	0	–
0	0	1	≤ 1.72 G
0	1	0	1.72 to 3.46 G
0	1	1	3.46 to 6.91 G
1	0	0	6.91 to 13.8 G
1	0	1	13.8 to 27.6 G
1	1	0	27.6 to 41.5 G
1	1	1	> 41.5 G

Output Protocol in Fault Condition

The A19351 sensor IC contains diagnostic circuitry that will continuously monitor the occurrences of failure defects within the IC. Refer to Figure 11 for the output protocol after a fault has been detected.

Note: If a fault exists continuously, the device output will remain at the I_{FAULT} level. Refer to the A19351 Safety Manual for additional details.

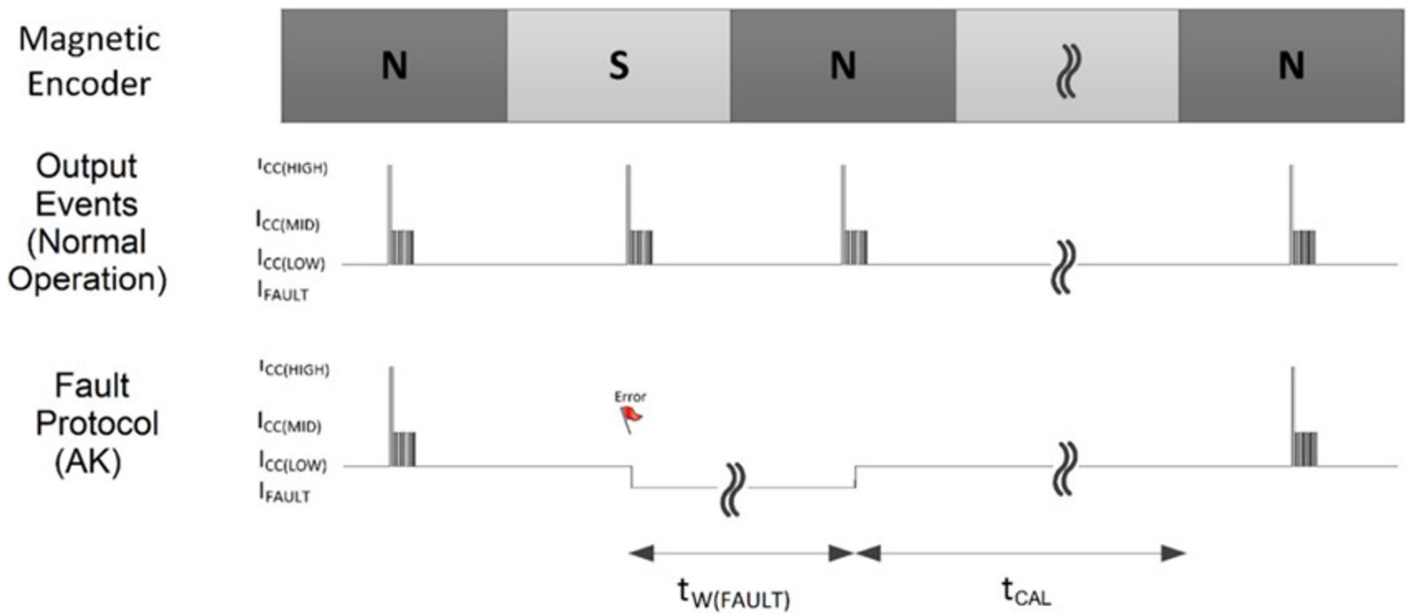

Figure 11: Output Protocols in Fault Condition

Calibration and Direction Validation

When power is applied to the A19351, the built-in algorithm performs an initialization routine. For a short period after power-on, the device calibrates itself and determines the direction of target rotation. The output does not transmit any output words during calibration. Once the calibration routine is complete, the A19351 will transmit accurate speed and direction information via AK protocol.

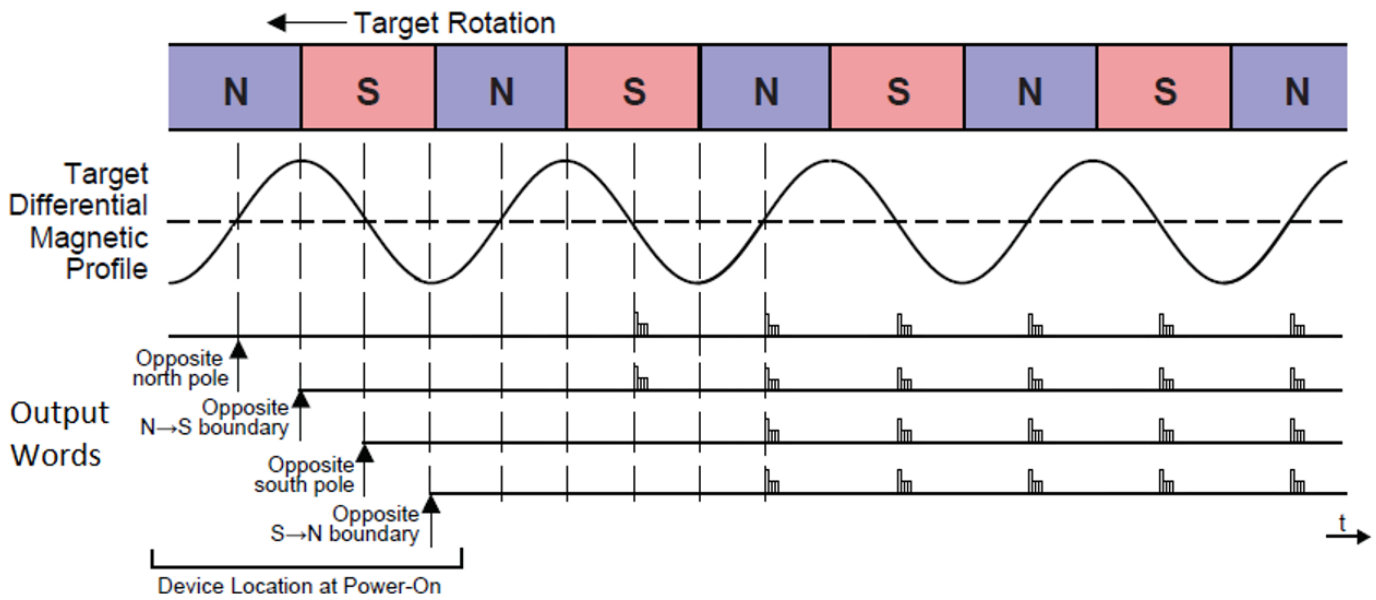

Figure 12: Calibration Behavior

Direction Changes, Vibrations, and Anomalous Events

During normal operation, the A19351 will be exposed to changes in the direction of target rotation (Figure 13), vibrations of the target (Figure 14), and anomalous events such as sudden air gap changes. The A19351 will not transmit any pulses during vibrations.

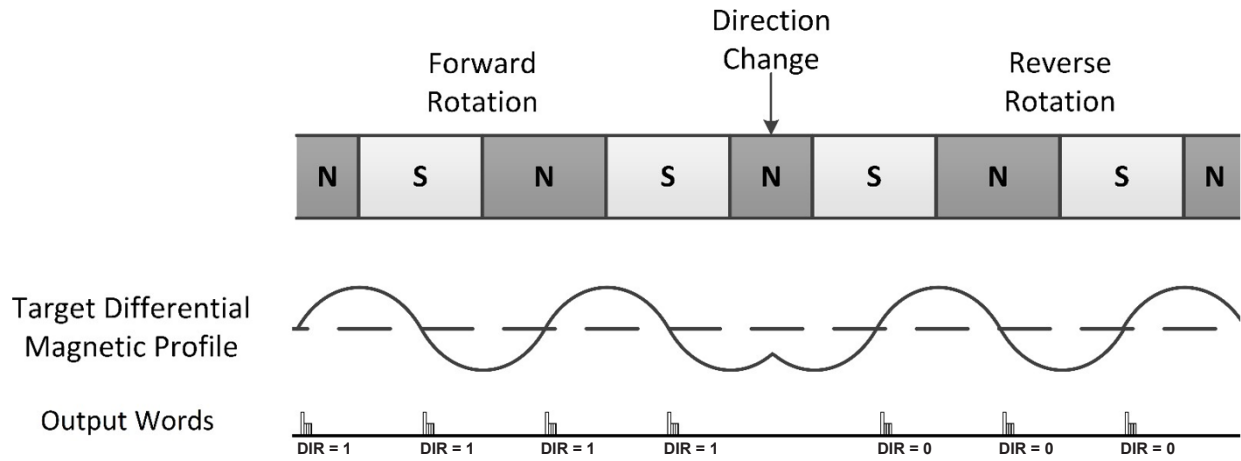

Figure 13: Direction Change Behavior

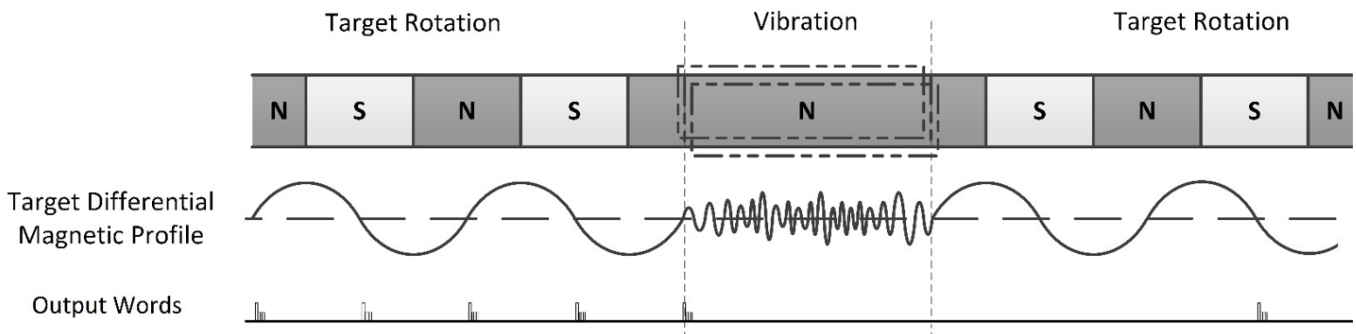

Figure 14: Vibration Behavior

POWER DERATING

The device must be operated below the maximum junction temperature of the device, $T_{J(max)}$. Under certain combinations of peak conditions, reliable operation may require derating supplied power or improving the heat dissipation properties of the application. This section presents a procedure for correlating factors affecting operating T_J . (Thermal data is also available on the Allegro MicroSystems website.)

The Package Thermal Resistance, $R_{\theta JA}$, is a figure of merit summarizing the ability of the application and the device to dissipate heat from the junction (die), through all paths to the ambient air. Its primary component is the Effective Thermal Conductivity, K , of the printed circuit board, including adjacent devices and traces. Radiation from the die through the device case, $R_{\theta JC}$, is a relatively small component of $R_{\theta JA}$. Ambient air temperature, T_A , and air motion are significant external factors, damped by overmolding.

The effect of varying power levels (Power Dissipation, P_D) can be estimated. The following formulas represent the fundamental relationships used to estimate T_J , at P_D .

$$P_D = V_{IN} \times I_{IN} \quad (1)$$

$$\Delta T = P_D \times R_{\theta JA} \quad (2)$$

$$T_J = T_A + \Delta T \quad (3)$$

For example, given common conditions such as:

$T_A = 25^\circ\text{C}$, $V_{CC} = 12\text{ V}$, $I_{CC} = 7.15\text{ mA}$, and $R_{\theta JA} = 213^\circ\text{C/W}$, then:

$$P_D = V_{CC} \times I_{CC} = 12\text{ V} \times 7.15\text{ mA} = 85.8\text{ mW}$$

$$\Delta T = P_D \times R_{\theta JA} = 85.8\text{ mW} \times 213^\circ\text{C/W} = 18.3^\circ\text{C}$$

$$T_J = T_A + \Delta T = 25^\circ\text{C} + 18.3^\circ\text{C} = 43.3^\circ\text{C}$$

A worst-case estimate, $P_{D(max)}$, represents the maximum allowable power level ($V_{CC(max)}$, $I_{CC(max)}$), without exceeding $T_{J(max)}$, at a selected $R_{\theta JA}$ and T_A .

Example: Reliability for V_{CC} at $T_A = 150^\circ\text{C}$, package UB, using minimum-K PCB.

Observe the worst-case ratings for the device, specifically:

$R_{\theta JA} = 213^\circ\text{C/W}$ (subject to change), $T_{J(max)} = 175^\circ\text{C}$, $V_{CC(max)} = 24\text{ V}$, and $I_{CC(AVG)} = 18.5\text{ mA}$. $I_{CC(AVG)}$ is computed using $I_{CC(HIGH)(max)}$, $I_{CC(MID)(max)}$, and $I_{CC(LOW)(max)}$ and maximum operational frequency of 4 kHz.

Calculate the maximum allowable power level, $P_{D(max)}$. First, invert equation 3:

$$\Delta T_{max} = T_{J(max)} - T_A = 175^\circ\text{C} - 150^\circ\text{C} = 25^\circ\text{C}$$

This provides the allowable increase to T_J resulting from internal power dissipation. Then, invert equation 2:

$$P_{D(max)} = \Delta T_{max} \div R_{\theta JA} = 25^\circ\text{C} \div 213^\circ\text{C/W} = 117.4\text{ mW}$$

Finally, invert equation 1 with respect to voltage:

$$V_{CC(est)} = P_{D(max)} \div I_{CC(max)} = 117.4\text{ mW} \div 18.5\text{ mA} = 6.3\text{ V}$$

The result indicates that, at T_A , the application and device can dissipate adequate amounts of heat at voltages $\leq V_{CC(est)}$.

Compare $V_{CC(est)}$ to $V_{CC(max)}$. If $V_{CC(est)} \leq V_{CC(max)}$, then reliable operation between $V_{CC(est)}$ and $V_{CC(max)}$ requires enhanced $R_{\theta JA}$. If $V_{CC(est)} \geq V_{CC(max)}$, then operation between $V_{CC(est)}$ and $V_{CC(max)}$ is reliable under these conditions.

Power Derating Curve

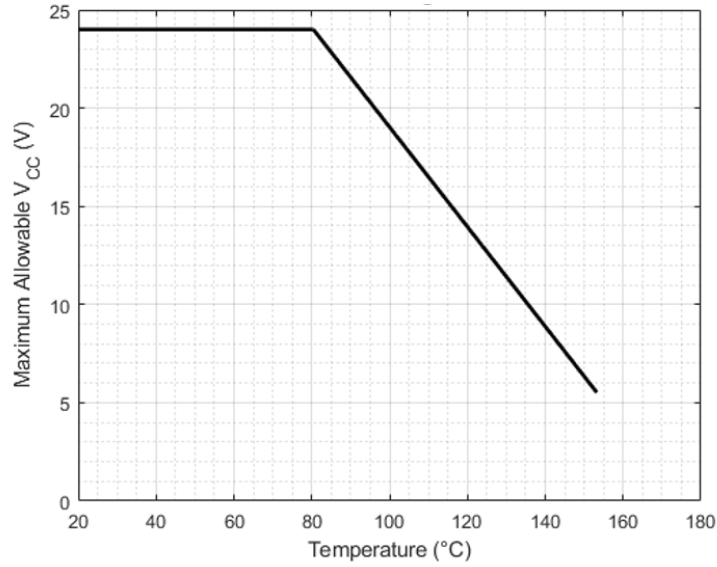

Power Dissipation versus Ambient Temperature

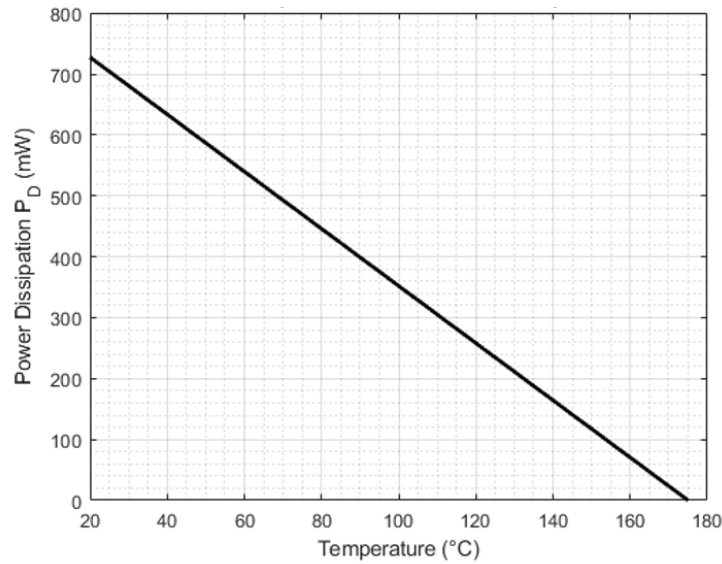

PACKAGE OUTLINE DRAWING

For Reference Only – Not for Tooling Use

(Reference DWG-0000408, Rev. 3)
Dimensions in millimeters – NOT TO SCALE
Dimensions exclusive of mold flash, gate burs, and dambar protrusions
Exact case and lead configuration at supplier discretion within limits shown

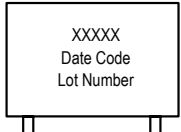
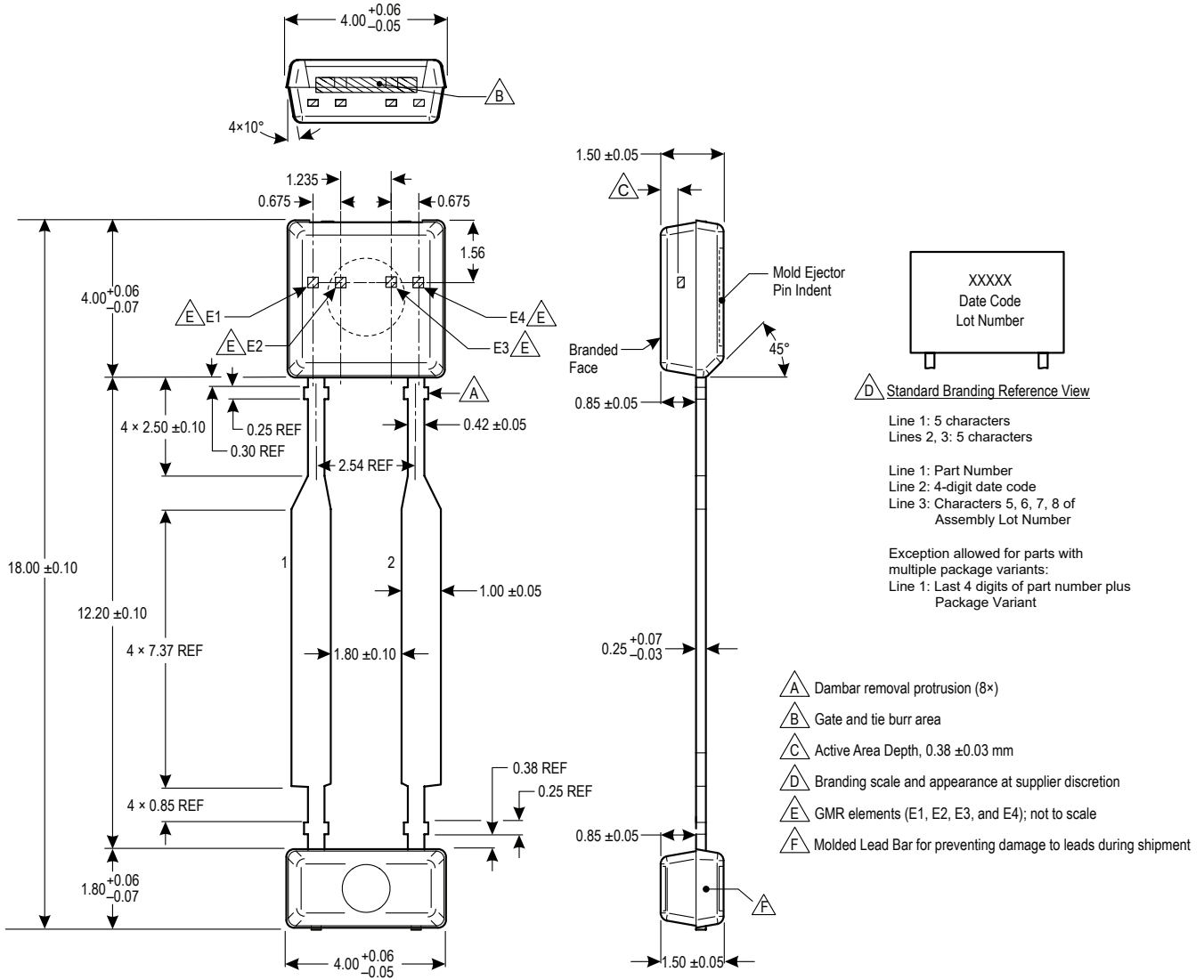

△ D Standard Branding Reference View

Line 1: 5 characters
Lines 2, 3: 5 characters

Line 1: Part Number
Line 2: 4-digit date code
Line 3: Characters 5, 6, 7, 8 of Assembly Lot Number

Exception allowed for parts with multiple package variants:
Line 1: Last 4 digits of part number plus Package Variant

- △ A Dambar removal protrusion (8×)
- △ B Gate and tie burr area
- △ C Active Area Depth, 0.38 ± 0.03 mm
- △ D Branding scale and appearance at supplier discretion
- △ E GMR elements (E1, E2, E3, and E4); not to scale
- △ F Molded Lead Bar for preventing damage to leads during shipment

Figure 15: Package UB, 2-Pin SIP