

AC axial fan

sickled blades (S series)

ebm-papst Mulfingen GmbH & Co. KG

Bachmühle 2 · D-74673 Mulfingen

Phone +49 7938 81-0

Fax +49 7938 81-110

info1@de.ebmpapst.com

www.ebmpapst.com

Limited partnership · Headquarters Mulfingen
County court Stuttgart · HRA 590344

General partner Elektrobau Mulfingen GmbH · Headquarters Mulfingen
County court Stuttgart · HRB 590142



Nominal data

Type	A2D250-AD26-05		
Motor	M2D068-DC		
Phase		3~	3~
Nominal voltage	VAC	400	480
Connection		Y	Y
Frequency	Hz	50	60
Type of data definition		cs	cs
Valid for approval / standard		CE	CE
Speed	min ⁻¹	2520	2920
Power input	W	150	230
Current draw	A	0.26	0.32
Min. ambient temperature	°C	-25	-25
Max. ambient temperature	°C	-	-

ml = max. load · me = max. efficiency · fa = running at free air · cs = customer specs · cu = customer unit
Subject to alterations

Data according to ErP directive

Installation category	A
Efficiency category	Static
Variable speed drive	No
Specific ratio*	1.00

* Specific ratio = $1 + p_{fs} / 100\,000\text{ Pa}$

	Actual	Request 2013	Request 2015
Overall efficiency η_{es}	24.7	24.6	28.6
Efficiency grade N	36.1	36	40
Power input P_e	kW	0.16	
Air flow q_v	m ³ /h	800	
Pressure increase p_{fs}	Pa	185	
Speed n	min ⁻¹	2450	

Data established at point of optimum efficiency



AC axial fan

sickled blades (S series)

Technical features

Mass	2.14 kg
Size	250 mm
Surface of rotor	Coated in black
Material of blades	Sheet steel, coated in black
Number of blades	5
Direction of air flow	"V"
Direction of rotation	Counter-clockwise, seen on rotor
Type of protection	IP 44; Depending on installation and position as per EN 60034-5
Insulation class	"F"
Humidity class	F2-2
Max. permissible ambient motor temp. (transp./ storage)	+ 80 °C
Min. permissible ambient motor temp. (transp./storage)	- 40 °C
Mounting position	Shaft horizontal or rotor on bottom; rotor on top on request
Condensate discharge holes	Rotor-side
Operation mode	S1
Motor bearing	Ball bearing
Touch current acc. IEC 60990 (measuring network Fig. 4, TN system)	< 0.75 mA
Cable exit	Lateral
Protection class	I (if protective earth is connected by customer)
Product conforming to standard	EN 60335-1
Approval	UL 1004-1; CSA C22.2 Nr.100



Product drawing

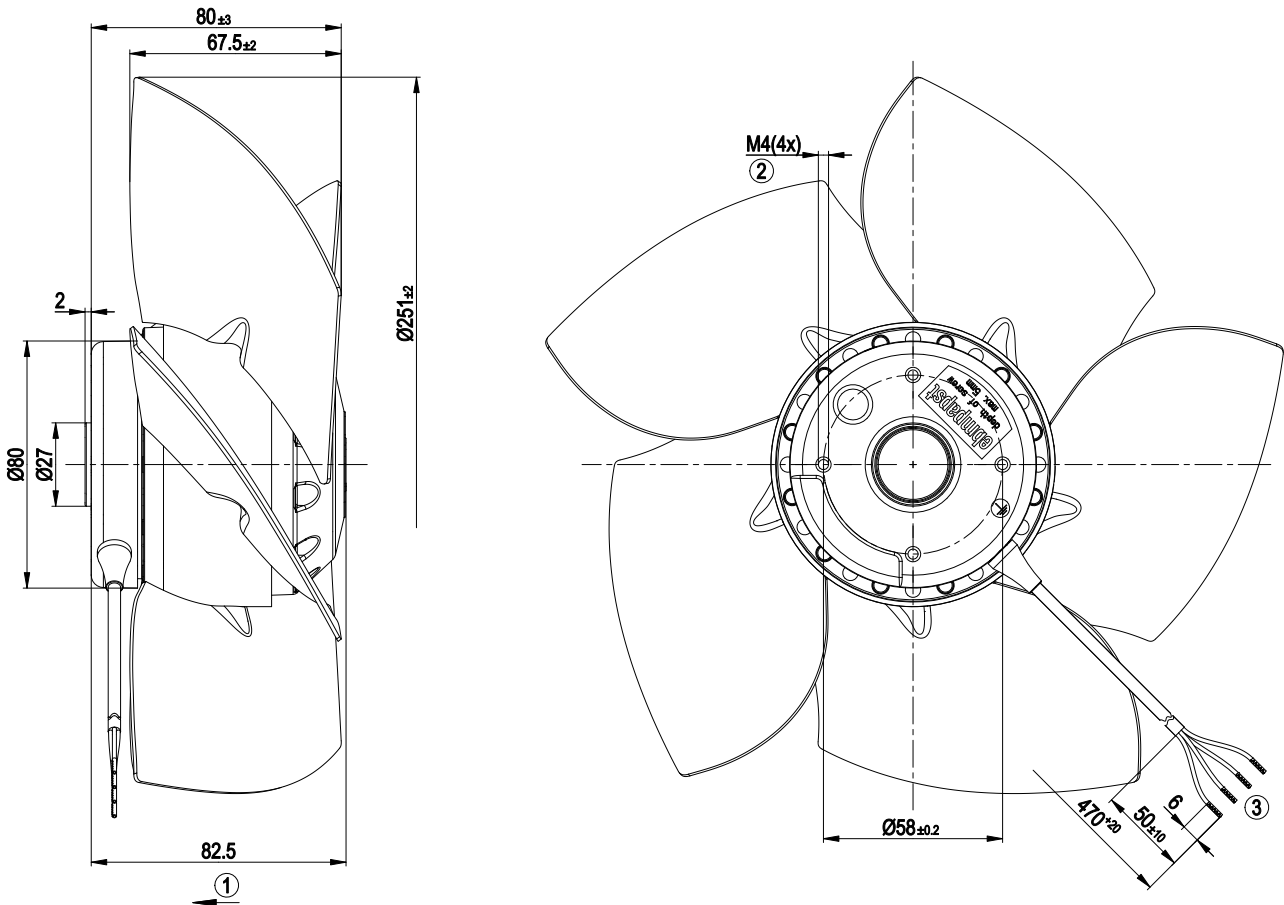

- | | |
|---|--|
| 1 | Direction of air flow "V" |
| 2 | Depth of screw max. 5 mm |
| 3 | Connection line PFA AWG20, 4 x brass lead tips crimped |

Connection screen

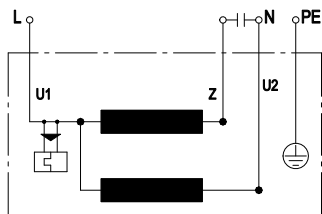

U1	blue	Z	brown	U2	black
PE	green/yellow				

Charts: Air flow 50 Hz

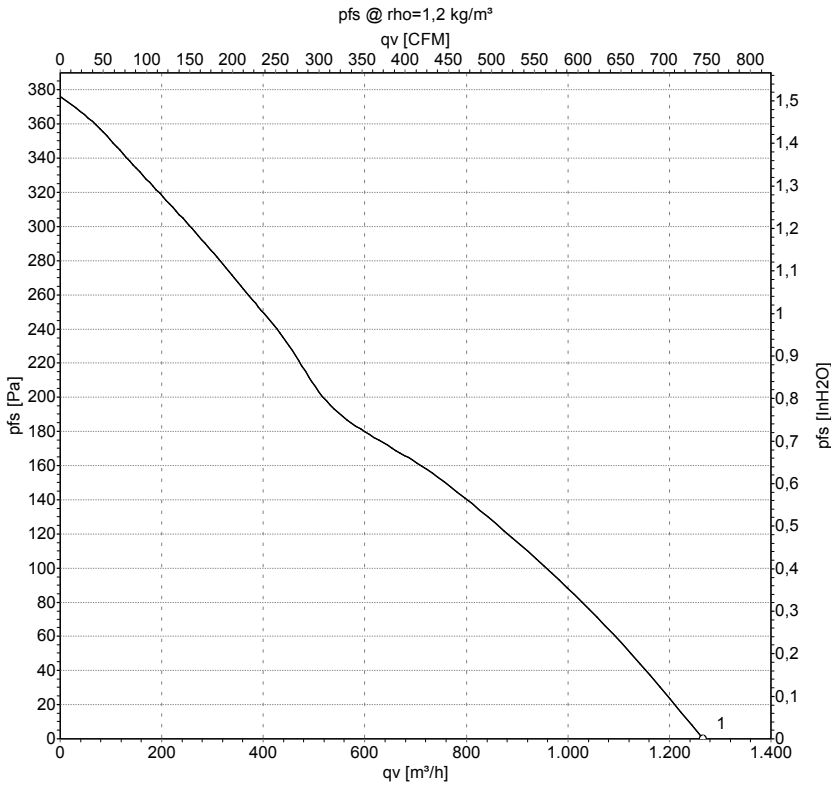

Measurement: LU-30683

Air performance measured as per ISO 5801 Installation category A. For detailed information on the measuring set-up, please contact ebm-papst. Suction-side noise levels: L_{wA} measured as per ISO 13347 / L_{pA} measured with 1m distance to fan axis. The values given are valid under the measuring conditions mentioned above and may vary according to the actual installation situation. With any deviation from the standard set-up, the specific values have to be checked and reviewed with the unit installed.

Measured values

	U	f	n	P _e	I	q _v
	V	Hz	min ⁻¹	W	A	m ³ /h
1	400	50	2585	137	0.25	1265

U = Supply voltage · f = Frequency · n = Speed · P_e = Power input · I = Current draw · q_v = Air flow

