

A2E250-AE65-02

AC axial fan

straight blades (A series)



ebm-papst Mulfingen GmbH & Co. KG

Bachmühle 2 · D-74673 Mulfingen

Phone +49 7938 81-0

Fax +49 7938 81-110

info1@de.ebmpapst.com

www.ebmpapst.com

Limited partnership · Headquarters Mulfingen

Amtsgericht (court of registration) Stuttgart · HRA 590344

General partner Elektrobau Mulfingen GmbH · Headquarters Mulfingen

Amtsgericht (court of registration) Stuttgart · HRB 590142

Nominal data

Type	A2E250-AE65-02			
Motor	M2E068-DF			
Phase		1~	1~	1~
Nominal voltage	VAC	230	230	230
Frequency	Hz	50	60	60
Method of obtaining data		fa	fa	fa
Valid for approval/standard		CE	CE	UL
Speed (rpm)	min ⁻¹	2550	2750	2750
Power consumption	W	115	165	175
Current draw	A	0.51	0.74	0.74
Capacitor	µF	4	4	4
Capacitor voltage	VDB	400	400	400
Capacitor standard		S0 (CE)	S0 (CE)	UL
Max. back pressure	Pa	150	130	130
Max. back pressure	in. wg	0.6	0.52	0.52
Min. ambient temperature	°C	-25	-25	-25
Max. ambient temperature	°C	55	50	50
Starting current	A	0.9	0.9	0.9

ml = Max. load · me = Max. efficiency · fa = Free air · cs = Customer specification · ce = Customer equipment
Subject to change



Technical description

Weight	2.2 kg
Fan size	250 mm
Rotor surface	Painted black
Impeller material	Sheet steel, painted black
Number of blades	5
Airflow direction	"A"
Direction of rotation	Clockwise, viewed toward rotor
Degree of protection	IP44
Insulation class	"B"
Moisture (F) / Environmental (H) protection class	H1
Max. permitted ambient temp. for motor (transport/storage)	+ 80 °C
Min. permitted ambient temp. for motor (transport/storage)	- 40 °C
Installation position	Shaft horizontal or rotor on bottom; rotor on top on request
Condensation drainage holes	On rotor side
Mode	S1
Motor bearing	Ball bearing
Touch current according to IEC 60990 (measuring circuit Fig. 4, TN system)	< 0.75 mA
Motor protection	Thermal overload protector (TOP) internally connected
With cable	Variable
Protection class	I (with customer connection of protective earth)
Conformity with standards	EN 60335-1; CE
Approval	CCC; EAC

Product drawing

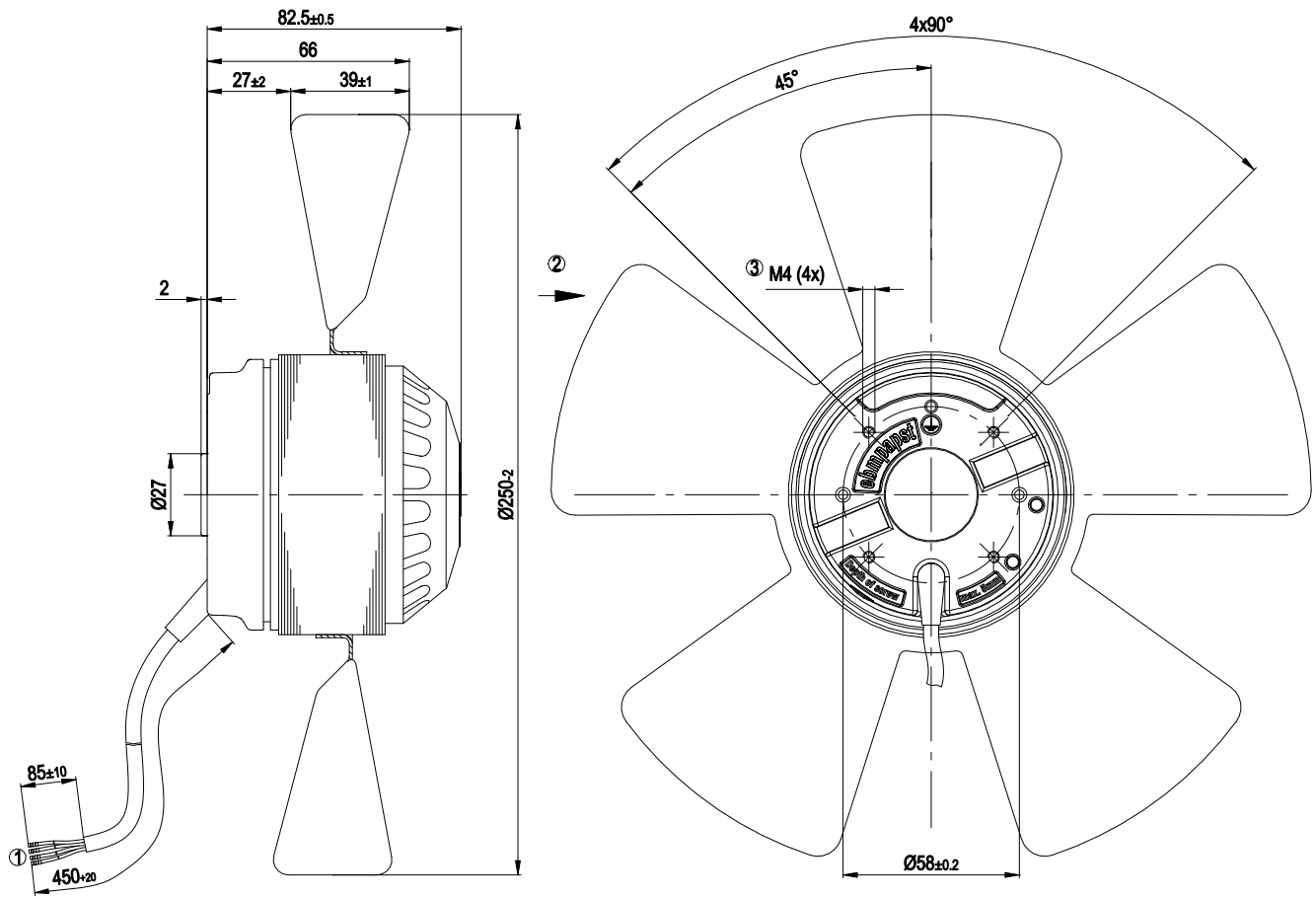

- 1 Cable PVC 4G 0.5 mm², 4x crimped splices
- 2 Direction of air flow "A"
- 3 Max. clearance for screw 5 mm

Connection diagram

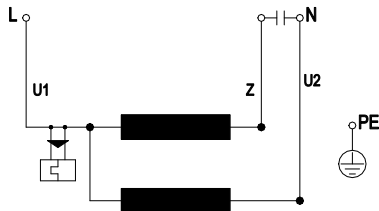

U1	blue	Z	brown	U2	black
PE	green/yellow				

Curves: Air performance 50 Hz

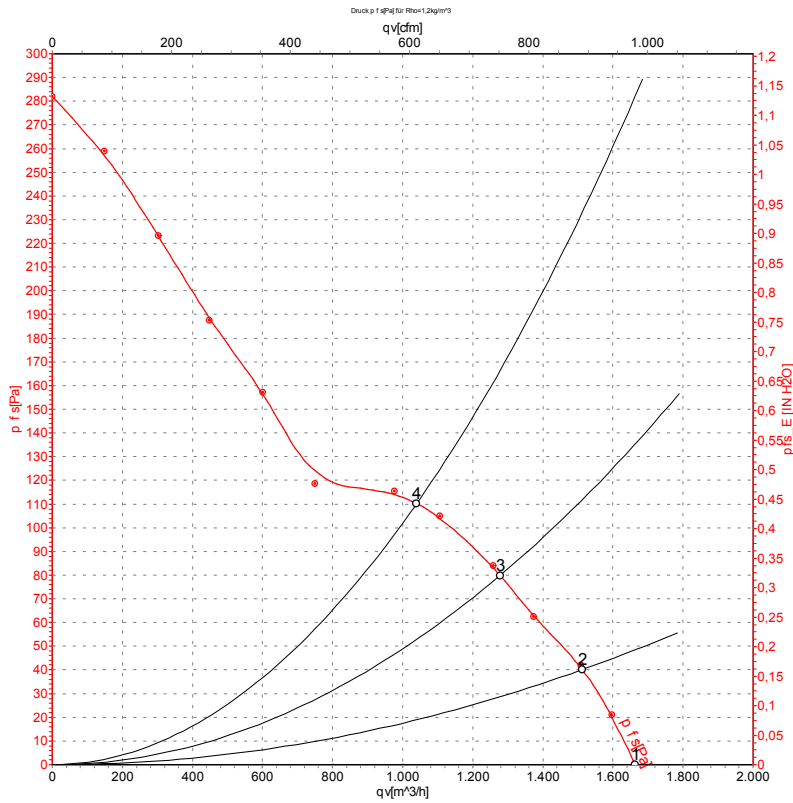

Measurement: LU-68411-1

Air performance measured according to ISO 5801 installation category A. For detailed information on the measurement setup, contact ebm-papst. Intake sound level: Sound power level according to ISO 13347 / sound pressure level measured at 1 m distance from fan axis. The values given are valid under the specified measuring conditions and may vary due to conditions of installation. For deviations from the standard configuration, the parameters have to be checked on the installed unit.

Measured values

	U	f	n	P _e	I	q _V	P _{is}	q _V	P _{is}
	V	Hz	min ⁻¹	W	A	m ³ /h	Pa	cfm	in. wg
1	230	50	2550	115	0.51	1660	0	975	0.00
2	230	50	2460	127	0.55	1515	40	890	0.16
3	230	50	2430	129	0.56	1280	80	750	0.32
4	230	50	2430	129	0.56	1040	110	610	0.44

U = Power supply · f = Frequency · n = Speed (rpm) · P_e = Power consumption · I = Current draw · q_V = Air flow · P_{is} = Pressure increase

