

Cascadable Amplifier 10 to 2000 MHz

Rev. V3

Features

- HIGH OUTPUT POWER: +19 dBm (TYP.)
- HIGH THIRD ORDER I.P.: +30 dBm (TYP.)
- WIDE BANDWIDTH: 10-2000 MHz

Description

The A38 RF amplifier is a discrete thin film hybrid design, which incorporates the use of thin film manufacturing processes for accurate performance and high reliability. This single stage bipolar transistor feedback amplifier design displays impressive performance over a broadband frequency range. An active DC biasing network is used for temperature-stable performance, in addition to an RF Choke, used for power supply decoupling. Both TO-8 and Surface Mount packages are hermetically sealed, and MIL-STD-883 environmental screening is available.

Ordering Information

Part Number	Package
A38	TO-8
SMA38	Surface Mount
CA38 **	SMA Connectorized

** The connectorized version is not RoHs compliant.

Product Image



Electrical Specifications: $Z_0 = 50\Omega$, $V_{CC} = +15 V_{DC}$

Parameter	Units	Typical	Guaranteed	
		25°C	0° to 50°C	-54° to +85°C*
Frequency	MHz	5-2050	10-2000	10-2000
Small Signal Gain (min)	dB	9.5	8.5	7.5
Gain Flatness (max)	dB	±0.4	±0.7	±1.0
Reverse Isolation	dB	15		
Noise Figure (max)	dB	6.5	7.7	8.2
Power Output @ 1 dB comp. (min)	dBm	19.0	18.0	17.5
IP3	dBm	+30		
IP2	dBm	+45		
Second Order Harmonic IP	dBm	+52		
VSWR Input / Output (max)		1.8:1 / 1.8:1	2.2:1 / 2.2:1	2.3:1 / 2.3:1
DC Current @ 15 Volts (max)	mA	65	69	72

Absolute Maximum Ratings

Parameter	Absolute Maximum
Storage Temperature	-62°C to +125°C
Case Temperature	125°C
DC Voltage	+17 V
Continuous Input Power	+17 dBm
Short Term Input power (1 minute max.)	100 mW
Peak Power (3 µsec max.)	0.5 W
"S" Series Burn-In Temperature (case)	125°C

Thermal Data: $V_{CC} = +15 V_{DC}$

Parameter	Rating
Thermal Resistance θ_{jc}	119°C/W
Transistor Power Dissipation P_d	0.659 W
Junction Temperature Rise Above Case T_{jc}	79°C

1 * Over temperature performance limits for part number CA38, guaranteed from 0°C to +50°C only.

Cascadable Amplifier 10 to 2000 MHz

Rev. V3

Typical Performance Curves at +25°C

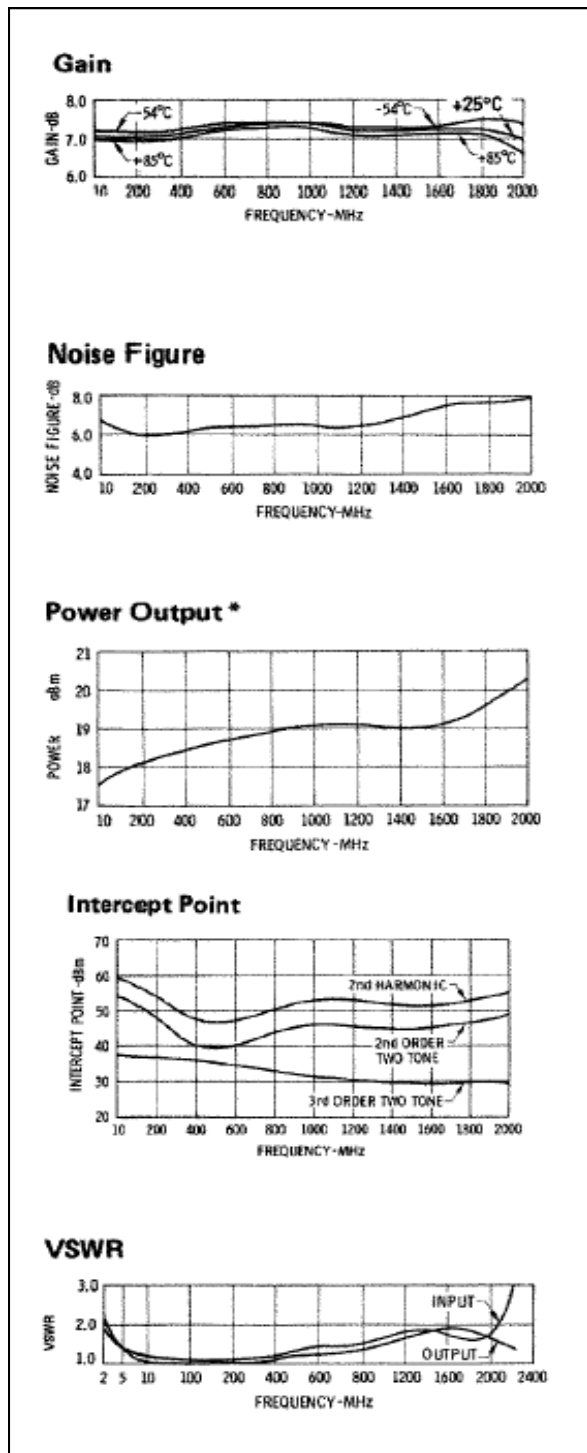

Outline Drawing: TO-8 *



Outline Drawing: Surface Mount *

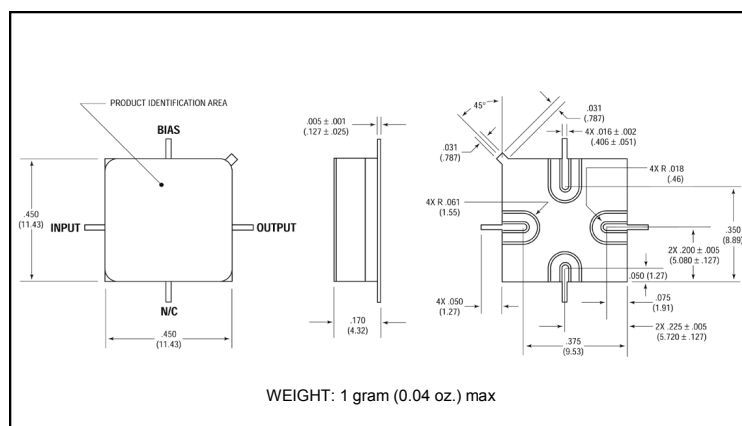

Outline Drawing: SMA Connectorized *

