

40MX and 42MX Automotive FPGA Families

Features

High Capacity

- Single-Chip ASIC Alternative for Automotive Applications
- 3,000 to 54,000 System Gates
- Up to 2.5 kbits Configurable Dual-Port SRAM
- Fast Wide-Decode Circuitry
- Up to 202 User-Programmable I/O Pins

Ease of Integration

- Up to 100% Resource Utilization and 100% Pin Locking
- Deterministic, User-Controllable Timing
- Unique In-System Diagnostic and Verification Capability with Silicon Explorer II
- Low Power Consumption
- IEEE Standard 1149.1 (JTAG) Boundary Scan Testing

Product Profile

Device	A40MX02	A40MX04	A42MX09	A42MX16	A42MX24	A42MX36
Capacity						
System Gates	3,000	6,000	14,000	24,000	36,000	54,000
SRAM Bits	–	–	–	–	–	2,560
Logic Modules						
Sequential	–	–	348	624	954	1,230
Combinatorial	295	547	336	608	912	1,184
Decode	–	–	–	–	24	24
SRAM Modules (64x4 or 32x8)	–	–	–	–	–	10
Dedicated Flip-Flops	–	–	348	624	954	1,230
Maximum Flip-Flops	147	273	516	928	1,410	1,822
Clocks	1	1	2	2	2	6
Maximum User I/Os	57	69	104	140	176	202
Boundary Scan Test (BST)	–	–	–	–	Yes	Yes
Packages (by pin count)						
PLCC	PL68	PL84	PL84	–	–	–
PQFP	PQ100	PQ100	PQ100, PQ160	PL208 PQ100	PQ160, PQ208	PQ208, PQ240
VQFP	VQ80	VQ80	VQ100	VQ176	–	–
TQFP	–	–	TQ176	–	TQ176	–

Note: While the automotive-grade MX devices are offered in standard speed grade only, the MX family is also offered in commercial, industrial and military temperature grades with -F, Std, -1, -2 and -3 speed grades. Refer to the 40MX and 42MX Family FPGAs datasheet for more details.

Ordering Information



Note: Automotive grade parts (A grade) devices are tested at room temperature to specifications that have been guard banded based on characterization across the recommended operating conditions. A-grade parts are not tested at extended temperatures. If testing to ensure guaranteed operation at extended temperatures is required, please contact your local SoC Products Group Sales office to discuss testing options available.

Plastic Device Resources

Device	User I/Os								
	PL68	PL84	PQ100	PQ160	PQ 208	PQ240	VQ80	VQ100	TQ176
A40MX02	57	–	57	–	–	–	57	–	–
A40MX04	–	69	69	–	–	–	69	–	–
A42MX09	–	72	83	101	–	–	–	83	104
A42MX16	–	–	–	–	140	–	–	83	140
A42MX24	–	–	–	125	176	–	–	–	150
A42MX36	–	–	–	–	176	202	–	–	–

Note: Package Definitions

PLCC = Plastic Leaded Chip Carrier, PQFP = Plastic Quad Flat Pack, TQFP = Thin Quad Flat Pack, VQFP = Very Thin Quad Flat Pack

Speed Grade and Temperature Grade Matrix

Application (Temperature Range)	Std
A	✓

Note: Refer to the 40MX and 42MX Family FPGAs datasheet for details on commercial-, industrial- and military-grade MX offerings.

Contact your local Microsemi SoC Products Group representative for device availability.

Table of Contents

40MX and 42MX Automotive FPGA Families

General Description	1-1
MX Architectural Overview	1-1
Other Architectural Features	1-6
Development Tool Support	1-12
Related Documents	1-12
5.0 V Operating Conditions	1-13
Power Dissipation	1-14
Junction Temperature	1-17
Package Thermal Characteristics	1-17
Timing Information	1-18
Parameter Measurement	1-21
Sequential Timing Characteristics	1-22
Predictable Performance: Tight Delay Distributions	1-28
Temperature and Voltage Derating Factors	1-29
Timing Characteristics	1-31
Pin Descriptions	1-47

Package Pin Assignments

PL68	2-1
PL84	2-3
PQ100	2-5
PQ160	2-8
VQ80	2-11
PQ208	2-13
PQ240	2-17
VQ100	2-20
TQ176	2-23

Datasheet Information

List of Changes	3-1
Datasheet Categories	3-2
Safety Critical, Life Support, and High-Reliability Applications Policy	3-2

1 – 40MX and 42MX Automotive FPGA Families

General Description

Microsemi's automotive-grade MX families provide a high-performance, single-chip solution for shortening the system design and development cycle, offering a cost-effective alternative to ASICs for in-cabin telematics and automobile interconnect applications. The 40MX and 42MX devices are excellent choices for integrating logic that is currently implemented in multiple PALs, CPLDs, and FPGAs.

The MX device architecture is based on Microsemi's patented antifuse technology implemented in a 0.45 μ m triple-metal CMOS process. With capacities ranging from 3,000 to 54,000 system gates, the MX devices are live on power-up and have one-fifth the standby power consumption of comparable FPGAs. MX FPGAs provide up to 202 user I/Os and are available in a wide variety of packages and speed grades.

The automotive-grade 42MX24 and 42MX36 include system-level features such as IEEE Standard 1149.1 (JTAG) Boundary Scan Testing and fast wide-decode modules. In addition, the A42MX36 device offers dual-port SRAM for implementing fast FIFOs, LIFOs, and temporary data storage. The storage elements can efficiently address applications requiring wide datapath manipulation.

MX Architectural Overview

The MX devices are composed of fine-grained building blocks that enable fast, efficient logic designs. All devices within these families are composed of logic modules, I/O modules, routing resources and clock networks, which are the building blocks for fast logic designs. In addition, the A42MX36 device contains embedded dual-port SRAM modules, which are optimized for high-speed datapath functions such as FIFOs, LIFOs and scratchpad memory. A42MX24 and A42MX36 also contain wide-decode modules.

Logic Modules

The 40MX logic module is an eight-input, one-output logic circuit designed to implement a wide range of logic functions with efficient use of interconnect routing resources ([Figure 1-1](#)).



Figure 1-1 • 40MX Logic Module

The logic module can implement the four basic logic functions (NAND, AND, OR and NOR) in gates of two, three, or four inputs. The logic module can also implement a variety of D-latches, exclusivity functions, AND-ORs and OR-ANDs. No dedicated hardwired latches or flip-flops are required in the array; latches and flip-flops can be constructed from logic modules whenever required in the application.

The 42MX devices contain three types of logic modules: combinatorial (C-modules), sequential (S-modules) and decode (D-modules). Figure 1-2 illustrates the combinatorial logic module.



Figure 1-2 • 42MX C-Module Implementation

The S-module, shown in Figure 1-3, implements the same combinatorial logic function as the C-module while adding a sequential element. The sequential element can be configured as either a D-flip-flop or a transparent latch. The S-module register can be bypassed so that it implements purely combinatorial logic.



Figure 1-3 • 42MX S-Module Implementation

A42MX24 and A42MX36 devices contain D-modules, which are arranged around the periphery of the device. D-modules contain wide-decode circuitry, providing a fast, wide-input AND function similar to that found in CPLD architectures (Figure 1-4).



Figure 1-4 • A42MX24 and A42MX36 D-Module Implementation

The D-module allows A42MX24 and A42MX36 devices to perform wide-decode functions at speeds comparable to CPLDs and PALs. The output of the D-module has a programmable inverter for active HIGH or LOW assertion. The D-module output is hardwired to an output pin, and can also be fed back into the array to be incorporated into other logic.

Dual-Port SRAM Modules

The A42MX36 device contains dual-port SRAM modules, which are arranged in 256-bit blocks and can be configured as 32x8 or 64x4. SRAM modules can be cascaded together to form memory spaces of user-definable width and depth. A block diagram of the A42MX36 dual-port SRAM block is shown in 1-3.



Figure 1-5 • A42MX36 Dual-Port SRAM Block

The A42MX36 SRAM modules are true dual-port structures containing independent read and write ports. Each SRAM module contains six bits of read and write addressing (RDAD[5:0] and WRAD[5:0], respectively) for 64x4-bit blocks. When configured in byte mode, the highest order address bits (RDAD5 and WRAD5) are not used. The read and write ports of the SRAM block contain independent clocks (RCLK and WCLK) with programmable polarities offering active HIGH or LOW implementation. The SRAM block contains eight data inputs (WD[7:0]) and eight outputs (RD[7:0]), which are connected to segmented vertical routing tracks.

The A42MX36 dual-port SRAM blocks provide an optimal solution for high-speed buffered applications requiring FIFO and LIFO queues. The ACTgen Macro Builder within Microsemi's Designer software provides capability to quickly design memory functions with the SRAM blocks.

Routing Structure

The MX architecture uses vertical and horizontal routing tracks to interconnect the various logic and I/O modules. These routing tracks are metal interconnects that may be continuous or split into segments. Varying segment lengths allow the interconnect of over 90% of design tracks to occur with only two antifuse connections. Segments can be joined together at the ends using antifuses to increase their lengths up to the full length of the track. All interconnects can be accomplished with a maximum of four antifuses.

Horizontal Routing

Horizontal routing tracks span the whole row length or are divided into multiple segments and are located in between the rows of modules. Any segment that spans more than one-third of the row length is considered a long horizontal segment. A typical channel is shown in [Figure 1-6](#). Within horizontal routing, dedicated routing tracks are used for global clock networks and for power and ground tie-off tracks. Non-dedicated tracks are used for signal nets.

Vertical Routing

Another set of routing tracks run vertically through the module. There are three types of vertical tracks: input, output, and long. Long tracks span the column length of the module, and can be divided into multiple segments. Each segment in an input track is dedicated to the input of a particular module; each segment in an output track is dedicated to the output of a particular module. Long segments are uncommitted and can be assigned during routing. Each output segment spans four channels (two above and two below), except near the top and bottom of the array, where edge effects occur. Long vertical tracks contain either one or two segments. An example of vertical routing tracks and segments is shown in [Figure 1-6](#).

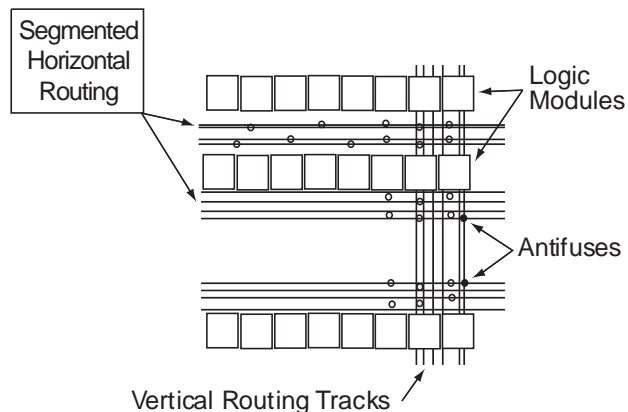

Figure 1-6 • MX Routing Structure

Antifuse Structures

An antifuse is a "normally open" structure. The use of antifuses to implement a programmable logic device results in highly testable structures as well as efficient programming algorithms. There are no pre-existing connections; temporary connections can be made using pass transistors. These temporary connections can isolate individual antifuses to be programmed and individual circuit structures to be tested, which can be done before and after programming. For instance, all metal tracks can be tested for continuity and shorts between adjacent tracks, and the functionality of all logic modules can be verified.

Clock Networks

The 40MX devices have one global clock distribution network (CLK). A signal can be put on the CLK network by being routed through the CLKBUF buffer.

In 42MX devices, there are two low-skew, high-fanout clock distribution networks, referred to as CLKA and CLKB. Each network has a clock module (CLKMOD) that can select the source of the clock signal from any of the following (Figure 1-7):

- Externally from the CLKA pad, using CLKBUF buffer
- Externally from the CLKB pad, using CLKBUF buffer
- Internally from the CLKINTA input, using CLKINT buffer
- Internally from the CLKINTB input, using CLKINT buffer



Figure 1-7 • Clock Networks of 42MX Devices

The clock modules are located in the top row of I/O modules. Clock drivers and a dedicated horizontal clock track are located in each horizontal routing channel.

Clock input pads in both 40MX and 42MX devices can also be used as normal I/Os, bypassing the clock networks.

The A42MX36 device has four additional register control resources, called quadrant clock networks (Figure 1-8). Each quadrant clock provides a local, high-fanout resource to the contiguous logic modules within its quadrant of the device. Quadrant clock signals can originate from specific I/O pins or from the internal array and can be used as a secondary register clock, register clear, or output enable.



*Note: *QCLK1IN, QCLK2IN, QCLK3IN, and QCLK4IN are internally-generated signals.*

Figure 1-8 • Quadrant Clock Network of A42MX36 Devices

I/O Modules

The I/O modules provide the interface between the device pins and the logic array. Figure 1-9 is a block diagram of the 42MX I/O module. A variety of user functions, determined by a library macro selection, can be implemented in the module. (Refer to the [Antifuse Macro Library Guide](#) for more information.) All 42MX I/O modules contain tristate buffers, with input and output latches that can be configured for input, output, or bidirectional operation.

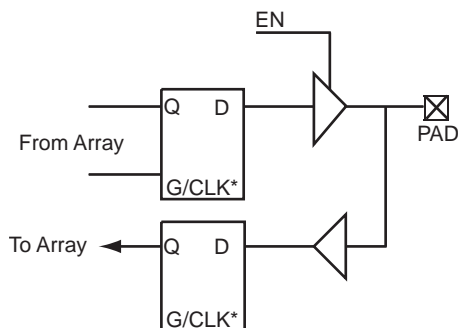

Note: *Can be configured as a latch or D flip-flop (using C-Module).

Figure 1-9 • 42MX I/O Module

42MX devices contain flexible I/O structures, where each output pin has a dedicated output-enable control (Figure 1-9). The I/O module can be used to latch input or output data, or both, providing fast setup time. In addition, the Microsemi Designer software tools can build a D-type flip-flop using a C-module combined with an I/O module to register input and output signals. Refer to the [Antifuse Macro Library Guide](#) for more details.

Microsemi's Designer software development tools provide a design library of I/O macro functions that can implement all I/O configurations supported by the MX FPGAs.

Other Architectural Features

User Security

FuseLock provides robust security against design theft. Special security fuses are hidden in the fabric of the device and are designed to prevent unauthorized users from accessing the programming and/or probe interfaces. It is virtually impossible to identify or bypass these fuses without damaging the device, making Microsemi antifuse FPGAs extremely resistive to both invasive and noninvasive attacks.

Special security fuses in 40MX devices include the Probe Fuse and Program Fuse. The former disables the probing circuitry while the latter prohibits further programming of all fuses, including the Probe Fuse. In 42MX devices, there is the Security Fuse which, when programmed, both disables the probing circuitry and prohibits further programming of the device.

For more information, refer to [Implementation of Security in Actel Antifuse FPGAs](#) application note.

Programming

Device programming is supported through the Silicon Sculptor series of programmers. Silicon Sculptor II is a compact, robust, single-site and multi-site device programmer for the PC. With standalone software, Silicon Sculptor II is designed to allow concurrent programming of multiple units from the same PC.

Silicon Sculptor II programs devices independently to achieve the fastest programming times possible. After being programmed, each fuse is verified to insure that it has been programmed correctly. Furthermore, at the end of programming, there are integrity tests that are run to ensure no extra fuses have been programmed. Not only does it test fuses (both programmed and nonprogrammed), Silicon Sculptor II also allows self-test to verify its own hardware extensively.

The procedure for programming an MX device using Silicon Sculptor II is as follows:

1. Load the *.AFM file
2. Select the device to be programmed
3. Begin programming

When the design is ready to go to production, Microsemi offers device volume-programming services either through distribution partners or via In-House Programming from the factory.

For more details on programming MX devices, please refer to the [Programming Antifuse Devices](#) and the [Silicon Sculptor II](#) user's guides.

Power Supply

Automotive MX devices are designed to operate in 5.0 V environments. [Table 1-1](#) describes the voltage settings of automotive MX devices.

Table 1-1 • Voltage Support of Automotive-Grade MX Devices

Device	VCC	VCCA	VCCI	Maximum Input Tolerance	Nominal Output Voltage
40MX	5.0 V	–	–	5.25 V	5.0 V
42MX	–	5.0 V	5.0 V	5.25V	5.0 V

Power-Up/Down

When powering up MX devices, VCCA must be greater than or equal to VCCI throughout the power-up sequence. If VCCI exceeds VCCA during power-up, either the input protection junction on the I/Os will be forward-biased or the I/Os will be at logical High, and ICC rises to high levels. During power-down, VCCA must be smaller than or equal to VCCI.

Transient Current

Due to the simultaneous random logic switching activity during power-up, a transient current may appear on the core supply (VCC). Customers must use a regulator for the VCC supply that can source a minimum of 100 mA for transient current during power-up. Failure to provide enough power can prevent the system from powering up properly and result in functional failure. However, there are no reliability concerns, since transient current is distributed across the die instead of confined to a localized spot. Since the transient current is not due to I/O switching, its value and duration are independent of the VCCI.

Test Circuitry and Silicon Explorer II Probe

MX devices contain probing circuitry that provides built-in access to every node in a design, via the use of Silicon Explorer II. Silicon Explorer II is an integrated hardware and software solution that, in conjunction with the Designer software, allow users to examine any of the internal nodes of the device while it is operating in a prototyping or a production system. The user can probe an MX device without changing the placement and routing of the design and without using any additional resources. Silicon Explorer II's noninvasive method does not alter timing or loading effects, thus shortening the debug cycle and providing a true representation of the device under actual functional situations.

Silicon Explorer II samples data at 100 MHz (asynchronous) or 66 MHz (synchronous). Silicon Explorer II attaches to a PC's standard serial port, turning the PC into a fully functional 18-channel logic analyzer. Silicon Explorer II allows designers to complete the design verification process at their desks and reduces verification time from several hours per cycle to a few seconds.

Silicon Explorer II is used to control the MODE, DCLK, SDI and SDO pins in MX devices to select the desired nets for debugging. The user simply assigns the selected internal nets in the Silicon Explorer II software to the PRA/PRB output pins for observation. Probing functionality is activated when the MODE pin is held HIGH.

Figure 1-10 illustrates the interconnection between Silicon Explorer II and 40MX devices, while Figure 1-11 illustrates the interconnection between Silicon Explorer II and 42MX devices.



Figure 1-10 • Silicon Explorer II Setup with 40MX



Figure 1-11 • Silicon Explorer II Setup with 42MX

To allow for probing capabilities, the security fuses must not be programmed. (Refer to "User Security" on page 1-6 for the security fuses of 40MX and 42MX devices). Table 1-2 summarizes the possible device configurations for probing.

Table 1-2 • Device Configuration Options for Probe Capability

Security Fuse(s) Programmed	Mode	PRA, PRB ¹	SDI, SDO, DCLK ¹
No	Low	User I/Os ²	User I/Os ²
No	High	Probe Circuit Outputs	Probe Circuit Inputs
Yes	–	Probe Circuit Secured	Probe Circuit Secured

Notes:

1. Avoid using SDI, SDO, DCLK, PRA, and PRB pins as input or bidirectional ports. Since these pins are active during probing, input signals will not pass through these pins and may cause contention.
2. If no user signal is assigned to these pins, they will behave as unused I/Os in this mode. See the "Pin Descriptions" on page 1-47 for information on unused I/O pins.

PRA and PRB pins are dual-purpose pins. When the "Reserve Probe Pin" is checked in the Designer software, PRA and PRB pins are reserved as dedicated outputs for probing. If PRA and PRB pins are required as user I/Os to achieve successful layout and "Reserve Probe Pin" is checked, the layout tool will override the option and place user I/Os on PRA and PRB pins.

Design Consideration

It is recommended to use a series 70Ω termination resistor on every probe connector (SDI, SDO, MODE, DCLK, PRA and PRB). The 70Ω series termination is used to prevent data transmission corruption during probing and reading back the checksum.

IEEE Standard 1149.1 Boundary Scan Test (BST) Circuitry

Automotive-grade 42MX24 and 42MX36 devices are compatible with IEEE Standard 1149.1 (informally known as Joint Testing Action Group Standard or JTAG), which defines a set of hardware architecture and mechanisms for cost-effective, board-level testing. The basic MX boundary-scan logic circuit is composed of the TAP (test access port), TAP controller, test data registers and instruction register (Figure 1-12).



Figure 1-12 • 42MX IEEE 1149.1 Boundary Scan Circuitry

This circuit supports all mandatory IEEE 1149.1 instructions (EXTEST, SAMPLE/PRELOAD and BYPASS) and some optional instructions. Table 1-3 describes the ports that control JTAG testing, while Table 1-4 on page 1-10 describes the test instructions supported by these MX devices.

Table 1-3 • Test Access Port Descriptions

Port	Description
TMS (Test Mode Select)	Serial input for the test logic control bits. Data is captured on the rising edge of the test logic clock (TCK)
TCK (Test Clock Input)	Dedicated test logic clock used serially to shift test instruction, test data, and control inputs on the rising edge of the clock, and serially to shift the output data on the falling edge of the clock. The maximum clock frequency for TCK is 20 MHz
TDI (Test Data Input)	Serial input for instruction and test data. Data is captured on the rising edge of the test logic clock
TDO (Test Data Output)	Serial output for test instruction and data from the test logic. TDO is set to an Inactive Drive state (high impedance) when data scanning is not in progress

Each test section is accessed through the TAP, which has four associated pins: TCK (test clock input), TDI and TDO (test data input and output), and TMS (test mode selector).

The TAP controller is a four-bit state machine. The '1's and '0's represent the values that must be present at TMS at a rising edge of TCK for the given state transition to occur. IR and DR indicate that the instruction register or the data register is operating in that state.

Table 1-4 • Supported BST Public Instructions

Instruction	IR Code [2:0]	Instruction Type	Description
EXTTEST	000	Mandatory	Allows the external circuitry and board-level interconnections to be tested by forcing a test pattern at the output pins and capturing test results at the input pins
SAMPLE/PRELOAD	001	Mandatory	Allows a snapshot of the signals at the device pins to be captured and examined during operation
HIGH Z	101	Optional	Tristates all I/Os to allow external signals to drive pins. Please refer to the IEEE Standard 1149.1 specification for details
CLAMP	110	Optional	Allows state of signals driven from component pins to be determined from the Boundary-Scan Register. Please refer to the IEEE Standard 1149.1 specification for details
BYPASS	111	Mandatory	Enables the bypass register between the TDI and TDO pins. The test data passes through the selected device to adjacent devices in the test chain

The TAP controller receives two control inputs (TMS and TCK) and generates control and clock signals for the rest of the test logic architecture. On power-up, the TAP controller enters the Test-Logic-Reset state. To guarantee a reset of the controller from any of the possible states, TMS must remain high for five TCK cycles.

Automotive-grade 42MX24 and 42MX36 devices support three types of test data registers: bypass, device identification, and boundary scan. The bypass register is selected when no other register needs to be accessed in a device. This speeds up test data transfer to other devices in a test data path. The 32-bit device identification register is a shift register with four fields (lowest significant byte (LSB), ID number, part number and version). The boundary-scan register observes and controls the state of each I/O pin.

Each I/O cell has three boundary-scan register cells, each with a serial-in, serial-out, parallel-in, and parallel-out pin. The serial pins are used to serially connect all the boundary-scan register cells in a device into a boundary-scan register chain, which starts at the TDI pin and ends at the TDO pin. The parallel ports are connected to the internal core logic tile and the input, output and control ports of an I/O buffer to capture and load data into the register to control or observe the logic state of each I/O.

JTAG Mode Activation

The JTAG test logic circuit is activated in the Designer software by selecting Tools and then Device Selection. This brings up the Device Selection dialog box as shown in Figure 1-13. The JTAG test logic circuit can be enabled by clicking the "Reserve JTAG Pins" check box. Table 1-5 explains the pins' behavior in either mode.



Figure 1-13 • Device Selection Wizard

Table 1-5 • Boundary Scan Pin Configuration and Functionality

Reserve JTAG	Checked	Unchecked
TCK	BST input; must be terminated to logical HIGH or LOW to avoid floating	User I/O
TDI, TMS	BST input; may float or be tied to HIGH. TDI may be tied to TDO of another device	User I/O
TDO	BST output; may float or be connected to TDI of another device	User I/O

TRST Pin and TAP Controller Reset

An active reset (TRST) pin is not supported; however, MX devices contain power-on circuitry that resets the boundary-scan circuitry upon power-up. Also, the TMS pin is equipped with an internal pull-up resistor. This allows the TAP controller to remain in or return to the Test-Logic-Reset state when there is no input or when a logical 1 is on the TMS pin. To reset the controller, TMS must be HIGH for at least five TCK cycles.

Boundary Scan Description Language (BSDL) File

Conforming to the IEEE Standard 1149.1 requires that the operation of the various JTAG components be documented. The BSDL file provides the standard format to describe the JTAG components that can be used by automatic test equipment software. The file includes the instructions that are supported, instruction-bit pattern, and the boundary-scan chain order. For an in-depth discussion on BSDL files, please refer to *Actel BSDL Files Format Description* application note.

BSDL files are grouped into two categories—generic and device-specific. The generic files assign all user I/Os as inouts. Device-specific files assign user I/Os as inputs, outputs, or inouts.

Generic files for MX devices are available on the Microsemi SoC Products Group website at <http://www.microsemi.com/soc/techdocs/models/bsdl.html>.

Development Tool Support

The automotive-grade MX family of FPGAs is fully supported by Libero® Integrated Design Environment (IDE). Libero IDE is a design management environment, seamlessly integrating design tools while guiding the user through the design flow, managing all design and log files, and passing necessary design data among tools. Libero IDE allows users to integrate both schematic and HDL synthesis into a single flow and verify the entire design in a single environment. Libero IDE includes SynplifyPro from Synopsys, ModelSim® HDL Simulator from Mentor Graphics,® and Viewdraw.

Libero IDE includes place-and-route and provides a comprehensive suite of backend support tools for FPGA development, including timing-driven place-and-route, and a world-class integrated static timing analyzer and constraints editor.

Additionally, the back-annotation flow is compatible with all the major simulators and the simulation results can be cross-probed with Silicon Explorer II, Microsemi's integrated verification and logic analysis tool. Another tool included in the Libero software is the SmartGen macro builder, which easily creates popular and commonly used logic functions for implementation into your schematic or HDL design.

Microsemi's Libero software is compatible with the most popular FPGA design entry and verification tools from companies such as Mentor Graphics, Synopsys, and Cadence Design Systems.

Refer to the Libero IDE web content at www.microsemi.com/soc/products/software/libero/default.aspx for further information on licensing and current operating system support.

Related Documents

Application Notes

Actel BSDL Files Format Description

www.microsemi.com/soc/documents/BSDLformat_AN.pdf

Programming Antifuse Devices

http://www.microsemi.com/soc/documents/AntifuseProgram_AN.pdf

Implementation of Security in Actel Antifuse FPGAs

www.microsemi.com/soc/documents/Antifuse_Security_AN.pdf

User's Guides and Manuals

Antifuse Macro Library Guide

www.microsemi.com/soc/documents/libguide_UG.pdf

Silicon Sculptor II

www.microsemi.com/soc/techdocs/manuals/default.asp#programmers

Miscellaneous

Libero IDE Flow Diagram

www.microsemi.com/soc/products/tools/libero/flow.html

5.0 V Operating Conditions

Absolute Maximum Ratings*

Free Air Temperature Range

Symbol	Parameter	Limits	Units
VCC/VCCA/VCCI	DC Supply Voltage	-0.5 to +6.5	V
VI	Input Voltage	-0.5 to VCC +0.5	V
VO	Output Voltage	-0.5 to VCC +0.5	V
T _{STG}	Storage Temperature	-65 to +150	°C

Note: *Stresses beyond those listed under “Absolute Maximum Ratings” may cause permanent damage to the device. Exposure to absolute maximum rated conditions for extended periods may affect device reliability. Devices should not be operated outside the Recommended Operating Conditions.

Recommended Operating Conditions

Parameter	Automotive ¹	Units
Temperature Range ²	-40 to +125	°C
VCCI	4.75 to 5.25	V
VCCA	4.75 to 5.25	V
VCC	4.75 to 5.25	V

Notes:

1. Automotive grade parts (A grade) devices are tested at room temperature to specifications that have been guard banded based on characterization across the recommended operating conditions. A-grade parts are not tested at extended temperatures. If testing to ensure guaranteed operation at extended temperatures is required, please contact your local Microsemi SoC Products Group Sales office to discuss testing options available.
2. Ambient temperature (T_A)

Electrical Specifications

Symbol	Parameter	Conditions	Automotive		Units
			Min.	Max.	
VOH ¹	Output High Voltage	(IOH = -4 mA)	3.1		V
VOL ¹	Output Low Voltage	(IOL = 4 mA)		0.4	V
VIL	Input Low Voltage			0.6	V
VIH	Input High Voltage		2.1		V
IIL, IIH	Input Leakage Current		-20	20	µA
IOZ	Tristate Output Leakage Current		-20	20	µA
t _R , t _F	Input Transition Time			250	ns
C _{IO}	I/O Capacitance			10	pF
ICC ²	Standby Current			35	mA
IIO	I/O source sink current	Can be derived from the IBIS model: (http://www.microsemi.com/soc/techdocs/models/ibis.html)			

Notes:

1. Only one output tested at a time. VCC/VCCI = min.
2. All outputs unloaded. All inputs = VCC/VCCI or GND.

Power Dissipation

General Power Equation

$$P = [ICC_{\text{standby}} + ICC_{\text{active}}] * V_{CC1} + I_{OL} * V_{OL} * N \\ + I_{OH} * (V_{CC1} - V_{OH}) * M$$

where:

ICC_{standby} is the current flowing when no inputs or outputs are changing.

ICC_{active} is the current flowing due to CMOS switching.

I_{OL}, I_{OH} are TTL sink/source currents.

V_{OL}, V_{OH} are TTL level output voltages.

N equals the number of outputs driving TTL loads to V_{OL}.

M equals the number of outputs driving TTL loads to V_{OH}.

Accurate values for N and M are difficult to determine because they depend on the family type, on design details, and on the system I/O. The power can be divided into two components: static and active.

Static Power Component

Microsemi FPGAs have small static power components that result in power dissipation lower than PALs or CPLDs. By integrating multiple PALs/CPLDs into one FPGA, an even greater reduction in board-level power dissipation can be achieved.

The power due to standby current is typically a small component of the overall power.

The static power dissipation by TTL loads depends on the number of outputs driving High or Low, and on the DC load current. Again, this number is typically small. For instance, a 32-bit bus sinking 4 mA at 0.33V will generate 42 mW with all outputs driving LOW, and 140 mW with all outputs driving HIGH. The actual dissipation will average somewhere in between, as I/Os switch states with time.

Active Power Component

Power dissipation in CMOS devices is usually dominated by the active (dynamic) power dissipation. This component is frequency-dependent and a function of the logic and the external I/O. Active power dissipation results from charging internal chip capacitances of the interconnect, unprogrammed antifuses, module inputs, and module outputs, plus external capacitance due to PC board traces and load device inputs. An additional component of the active power dissipation is the totem pole current in the CMOS transistor pairs. The net effect can be associated with an equivalent capacitance that can be combined with frequency and voltage to represent active power dissipation.

The power dissipated by a CMOS circuit can be expressed by the equation:

$$\text{Power } (\mu\text{W}) = C_{EQ} * V_{CCA}^2 * F$$

EQ 1

where:

C_{EQ} = Equivalent capacitance expressed in picofarads (pF)

V_{CCA} = Power supply in volts (V)

F = Switching frequency in megahertz (MHz)

Equivalent Capacitance

Equivalent capacitance is calculated by measuring ICC_{active} at a specified frequency and voltage for each circuit component of interest. Measurements have been made over a range of frequencies at a fixed value of V_{CC}. Equivalent capacitance is frequency-independent, so the results can be used over a wide range of operating conditions. Equivalent capacitance values are shown on the following page.

C_{EQ} Values for MX FPGAs

Modules (C _{EQM})	3.5
Input Buffers (C _{EQI})	6.9
Output Buffers (C _{EQO})	18.2
Routed Array Clock Buffer Loads (C _{EQCR})	1.4

To calculate the active power dissipated from the complete design, the switching frequency of each part of the logic must be known. The equation below shows a piece-wise linear summation over all components.

$$\begin{aligned} \text{Power} = & VCCA^2 * [(m * C_{EQM} * f_m)_{\text{Modules}} + \\ & (n * C_{EQI} * f_n)_{\text{Inputs}} + (p * (C_{EQO} + C_L) * f_p)_{\text{Outputs}} + \\ & 0.5 * (q_1 * C_{EQCR} * f_{q1})_{\text{routed_Clk1}} + (r_1 * f_{q1})_{\text{routed_Clk1}} + \\ & 0.5 * (q_2 * C_{EQCR} * f_{q2})_{\text{routed_Clk2}} + (r_2 * f_{q2})_{\text{routed_Clk2}} \end{aligned}$$

EQ 2

where:

m	=	Number of logic modules switching at frequency f _m
n	=	Number of input buffers switching at frequency f _n
p	=	Number of output buffers switching at frequency f _p
q ₁	=	Number of clock loads on the first routed array clock
q ₂	=	Number of clock loads on the second routed array clock
r ₁	=	Fixed capacitance due to first routed array clock
r ₂	=	Fixed capacitance due to second routed array clock
C _{EQM}	=	Equivalent capacitance of logic modules in pF
C _{EQI}	=	Equivalent capacitance of input buffers in pF
C _{EQO}	=	Equivalent capacitance of output buffers in pF
C _{EQCR}	=	Equivalent capacitance of routed array clock in pF
C _L	=	Output load capacitance in p
f _m	=	Average logic module switching rate in MHz
f _n	=	Average input buffer switching rate in MHz
f _p	=	Average output buffer switching rate in MHz
f _{q1}	=	Average first routed array clock rate in MHz
f _{q2}	=	Average second routed array clock rate in MHz

Fixed Capacitance Values for MX FPGAs (pF)

Device Type	r1, routed_Clk1	r2, routed_Clk2
A40MX02	41.4	N/A
A40MX04	68.6	N/A
A42MX09	118	118
A42MX16	165	165
A42MX24	185	185
A42MX36	220	220

Determining Average Switching Frequency

To determine the switching frequency for a design, the data input values to the circuit must be clearly understood. The following guidelines represent worst-case scenarios; these can be used to generally predict the upper limits of power dissipation.

- Logic Modules (m) = 80% of Combinatorial Modules
- Inputs Switching (n) = # of Inputs/4
- Outputs Switching (p) = # of Outputs/4
- First Routed Array Clock Loads (q_1) = 40% of Sequential Modules
- Second Routed Array Clock Loads (q_2) = 40% of Sequential Modules
- Load Capacitance (C_L) = 35 pF
- Average Logic Module Switching Rate (f_m) = F/10
- Average Input Switching Rate (f_n) = F/5
- Average Output Switching Rate (f_p) = F/10
- Average First Routed Array Clock Rate (f_{q1}) = F
- Average Second Routed Array Clock Rate (f_{q2}) = F/2

Junction Temperature

The temperature variable in the Designer software refers to the junction temperature, not the ambient temperature. This is an important distinction because the heat generated from dynamic power consumption is usually hotter than the ambient temperature. EQ 3 can be used to calculate junction temperature.

$$\text{Junction Temperature} = \Delta T + T_a \quad (1)$$

EQ 3

Where:

T_a = Ambient Temperature

ΔT = Temperature gradient between junction (silicon) and ambient

$\Delta T = \theta_{ja} * P$

P = Power

θ_{ja} = Junction to ambient of package. θ_{ja} numbers are located in the "Package Thermal Characteristics".

Package Thermal Characteristics

The device junction-to-case thermal characteristic is θ_{jc} , and the junction-to-ambient air characteristic is θ_{ja} . The thermal characteristics for θ_{ja} are shown with two different air flow rates.

Maximum junction temperature is 150°C.

A sample calculation of the absolute maximum power dissipation allowed for a PQFP 160-pin package at automotive temperature is as follows:

$$\frac{\text{Max. junction temp. (°C)} - \text{Max. automotive temp.}}{\theta_{ja} \text{ (°C/W)}} = \frac{150^\circ\text{C} - 125^\circ\text{C}}{26.2^\circ\text{C/W}} = 0.95 \text{ W}$$

Table 1-6 • Package Thermal Characteristics

Plastic Packages	Pin Count	θ_{jc}	θ_{ja}			Units
			Still Air	1.0 m/s 200 ft./min.	2.5 m/s 500 ft./min.	
Plastic Quad Flat Pack	100	12.0	27.8	23.4	21.2	°C/W
Plastic Quad Flat Pack	160	10.0	26.2	22.8	21.1	°C/W
Plastic Quad Flat Pack	208	8.0	26.1	22.5	20.8	°C/W
Plastic Quad Flat Pack	240	8.5	25.6	22.3	20.8	°C/W
Plastic Leaded Chip Carrier	68	13.0	25.0	21.0	19.4	°C/W
Plastic Leaded Chip Carrier	84	12.0	22.5	18.9	17.6	°C/W
Thin Plastic Quad Flat Pack	176	11.0	24.7	19.9	18.0	°C/W
Very Thin Plastic Quad Flat Pack	80	12.0	38.2	31.9	29.4	°C/W
Very Thin Plastic Quad Flat Pack	100	10.0	35.3	29.4	27.1	°C/W

Timing Information



Note: * Values are shown for 40MX at worst-case 5.0 V automotive conditions.

Figure 1-14 • 40MX Timing Model*



Notes:

*Values are shown for A42MX09 at worst-case 5.0 V automotive conditions.

† Input module predicted routing delay

Figure 1-15 • 42MX Timing Model*



Notes:

* Values are shown for A42MX36 at worst-case 5.0V automotive conditions.
 †Load-dependent

Figure 1-16 • A42MX36 Timing Model (Logic Functions using Quadrant Clocks)*



*Note: *Values are shown for A42MX36 at worst-case 5.0 V automotive conditions.*

Figure 1-17 • A42MX36 Timing Model (SRAM Functions)*

Parameter Measurement



Figure 1-18 • Output Buffer Delays



Figure 1-19 • AC Test Loads

Sequential Timing Characteristics



Figure 1-20 • Input Buffer Delays



Figure 1-21 • Module Delays



Note: D represents all data functions involving A, B, and S for multiplexed flip-flops.

Figure 1-22 • Flip-Flops and Latches



Figure 1-24 • Output Buffer Latches



Figure 1-23 • Input Buffer Latches

Decode Module Timing

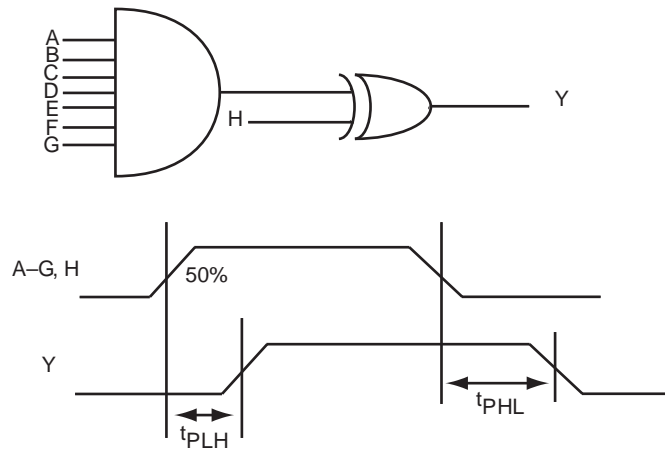

Figure 1-25 • Decode Module Timing

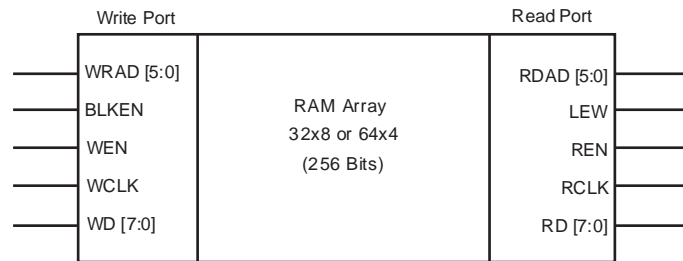

Figure 1-26 • SRAM Timing Characteristics

Dual-Port SRAM Timing Waveforms



Note: Identical timing for falling edge clock.

Figure 1-27 • 42MX SRAM Write Operation



Note: Identical timing for falling edge clock.

Figure 1-28 • 42MX SRAM Synchronous Read Operation

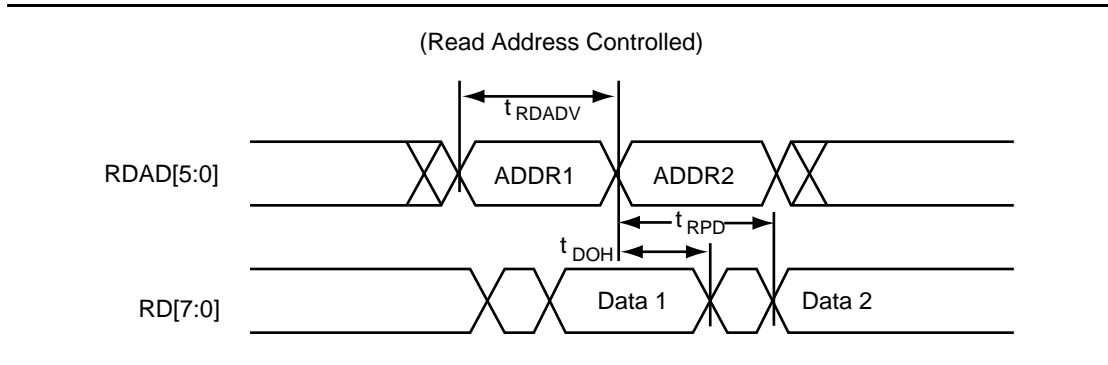

Figure 1-29 • 42MX SRAM Asynchronous Read Operation—Type 1

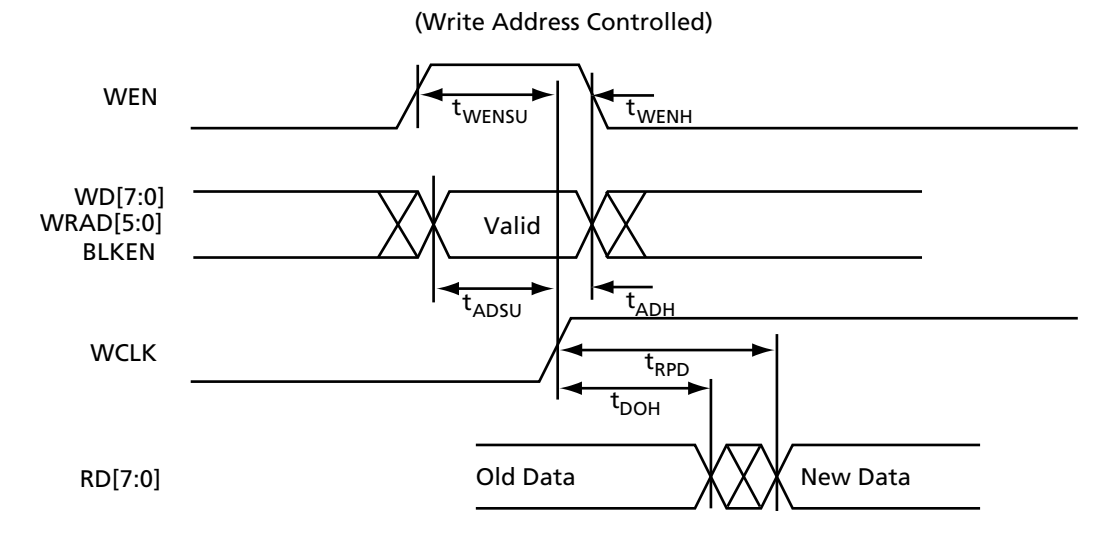

Figure 1-30 • 42MX SRAM Asynchronous Read Operation—Type 2

Predictable Performance: Tight Delay Distributions

Propagation delay between logic modules depends on the resistive and capacitive loading of the routing tracks, the interconnect elements, and the module inputs being driven. Propagation delay increases as the length of routing tracks, the number of interconnect elements, or the number of inputs increases.

From a design perspective, the propagation delay can be statistically correlated or modeled by the fanout (number of loads) driven by a module. Higher fanout usually requires some paths to have longer routing tracks.

The MX FPGAs deliver a tight fanout delay distribution, which is achieved in two ways: by decreasing the delay of the interconnect elements and by decreasing the number of interconnect elements per path.

Microsemi's patented antifuse offers a very low resistive/capacitive interconnect. The antifuses, fabricated in 0.45 μ lithography, offer nominal levels of 100 Ω resistance and 7.0 femtofarad (fF) capacitance per antifuse.

MX fanout distribution is also tight due to the low number of antifuses required for each interconnect path. The proprietary architecture limits the number of antifuses per path to a maximum of four, with 90 percent of interconnects using only two antifuses.

Timing Characteristics

Device timing characteristics fall into three categories: family-dependent, device-dependent, and design-dependent. The input and output buffer characteristics are common to all MX devices. Internal routing delays are device-dependent. Design dependency means actual delays are not determined until after place-and-route of the user's design is complete. Delay values may then be determined by using the Timer tool in the Designer software or by performing simulation with post-layout delays.

Critical Nets and Typical Nets

Propagation delays in this datasheet apply to typical nets, which are used for initial design performance evaluation. Critical net delays can then be applied to the most timing critical paths. Critical nets are determined by net property assignment in Designer software prior to placement and routing. Up to 6% of the nets in a design may be designated as critical.

Long Tracks

Some nets in the design use long tracks, which are special routing resources that span multiple rows, columns, or modules. Long tracks employ three and sometimes four antifuse connections, which increase capacitance and resistance, resulting in longer net delays for macros connected to long tracks. Typically, up to 6 percent of nets in a fully utilized device require long tracks. Long tracks add approximately a 3 ns to a 6 ns delay, which is represented statistically in higher fanout (FO=8) routing delays in the datasheet specifications section beginning on page 1-18.

Timing Derating

MX devices are manufactured with a CMOS process. Therefore, device performance varies according to temperature, voltage and process changes. Minimum timing parameters reflect maximum operating voltage, minimum operating temperature and best-case processing. Maximum timing parameters reflect minimum operating voltage, maximum operating temperature and worst-case processing.

Temperature and Voltage Derating Factors

Table 1-7 • 42MX Temperature and Voltage Derating Factors
(Normalized to $T_J = 125^\circ\text{C}$, $V_{CCA}/V_{CCI} = 4.75\text{ V}$)

42MX Voltage	Temperature						
	-55°C	-40°C	0°C	25°C	70°C	85°C	125°C
4.75	0.66	0.67	0.74	0.78	0.89	0.91	1.00
5.00	0.64	0.65	0.72	0.75	0.87	0.89	0.97
5.25	0.62	0.64	0.70	0.73	0.84	0.86	0.94

42MX Derating Factor (Normalized to $T_J = 125^\circ\text{C}$, $V_{CCA}/V_{CCI} = 4.75\text{ V}$)

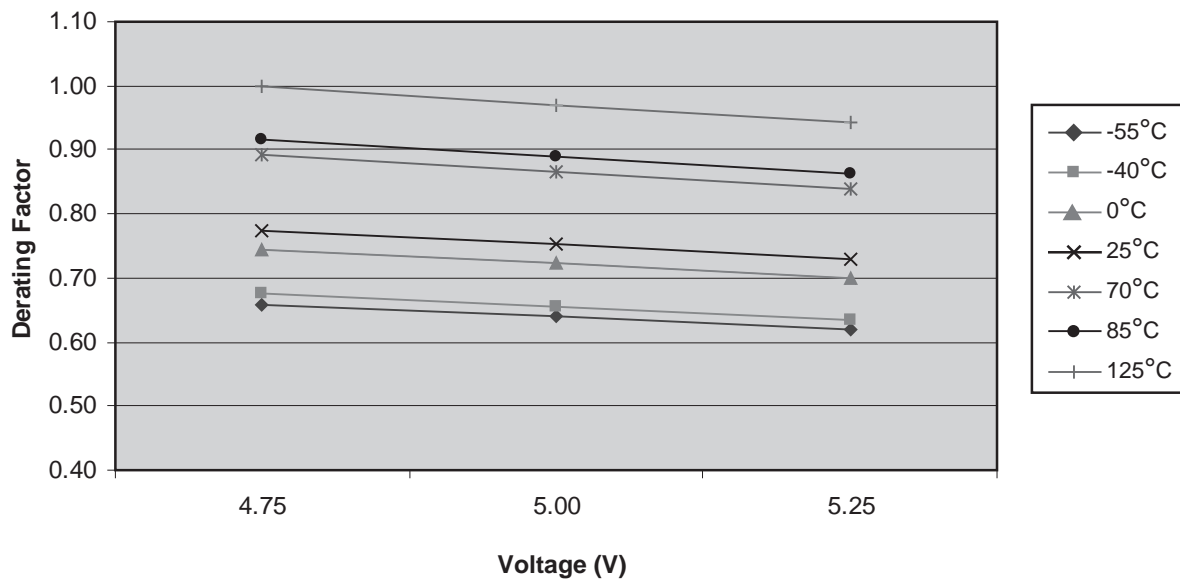

Note: This derating factor applies to all routing and propagation delays.

Figure 1-31 • 42MX Junction Temperature and Voltage Derating Curves
(Normalized to $T_J = 125^\circ\text{C}$, $V_{CCA}/V_{CCI} = 4.75\text{ V}$)

Table 1-8 • 40MX Temperature and Voltage Derating Factors
 (Normalized to $T_J = 125^\circ\text{C}$, $V_{CC} = 4.75\text{V}$)

40MX Voltage	Temperature						
	-55°C	-40°C	0°C	25°C	70°C	85°C	125°C
4.75	0.62	0.64	0.71	0.75	0.86	0.90	1.00
5.00	0.60	0.62	0.69	0.73	0.84	0.88	0.97
5.25	0.58	0.60	0.67	0.71	0.82	0.85	0.94



Note: This derating factor applies to all routing and propagation delays.

Figure 1-32 • 40MX Junction Temperature and Voltage Derating Curves
 (Normalized to $T_J = 125^\circ\text{C}$, $V_{CC} = 4.75\text{V}$)

Timing Characteristics

The timing numbers in the datasheet represent sample timing characteristics of the devices. Refer to the Timer tool in the Designer software for design-specific timing information.

**Table 1-9 • A40MX02 Timing Characteristics (Nominal 5.0V Operation)
Worst-Case Automotive Conditions, VCC = 4.75V, TJ = 125°C**

Parameter	Description	Std. Speed		Units
		Min.	Max.	
Logic Module Propagation Delays¹				
t _{PD1}	Single Module		2.2	ns
t _{PD2}	Dual-Module Macros		4.7	ns
t _{CO}	Sequential Clock-to-Q		2.2	ns
t _{GO}	Latch G-to-Q		2.2	ns
t _{RS}	Flip-Flop (Latch) Reset-to-Q		2.2	ns
Logic Module Predicted Routing Delays¹				
t _{RD1}	FO=1 Routing Delay		2.3	ns
t _{RD2}	FO=2 Routing Delay		3.2	ns
t _{RD3}	FO=3 Routing Delay		4.2	ns
t _{RD4}	FO=4 Routing Delay		5.1	ns
t _{RD8}	FO=8 Routing Delay		8.8	ns
Logic Module Sequential Timing²				
t _{SUD}	Flip-Flop (Latch) Data Input Set-Up	5.4		ns
t _{HD³}	Flip-Flop (Latch) Data Input Hold	0.0		ns
t _{SUENA}	Flip-Flop (Latch) Enable Set-Up	5.4		ns
t _{HENA}	Flip-Flop (Latch) Enable Hold	0.0		ns
t _{WCLKA}	Flip-Flop (Latch) Clock Active Pulse	5.8		ns
t _{WASYN}	Flip-Flop (Latch)	5.8		ns
t _A	Flip-Flop Clock Input Period	8.7		ns
f _{MAX}	Flip-Flop (Latch) Clock Frequency		116	MHz
Input Module Propagation Delays				
t _{INYH}	Pad-to-Y HIGH		1.3	ns
t _{INYL}	Pad-to-Y LOW		1.2	ns
Input Module Predicted Routing Delays¹				
t _{IRD1}	FO=1 Routing Delay		3.7	ns
t _{IRD2}	FO=2 Routing Delay		4.6	ns
t _{IRD3}	FO=3 Routing Delay		5.6	ns
t _{IRD4}	FO=4 Routing Delay		6.5	ns
t _{IRD8}	FO=8 Routing Delay		10.2	ns

Notes:

1. Routing delays are for typical designs across worst-case operating conditions. These parameters should be used for estimating device performance. Post-route timing analysis or simulation is required to determine actual performance.
2. Setup times assume a fanout of 3. Further testing information can be obtained from the Timer tool.
3. The hold time for the DFME1A macro may be greater than 0 ns. Use the Timer tool in Designer to check the hold time for this macro.
4. Delays based on 35 pF loading.

**Table 1-9 • A40MX02 Timing Characteristics (Nominal 5.0V Operation)
 Worst-Case Automotive Conditions, VCC = 4.75V, TJ = 125°C (continued)**

Parameter	Description	Std. Speed		Units
		Min.	Max.	
Global Clock Networks				
t _{CKH}	Input Low to HIGH	FO = 16	8.1	ns
		FO = 128	8.1	ns
t _{CKL}	Input High to LOW	FO = 16	8.6	ns
		FO = 128	8.6	ns
t _{PWH}	Minimum Pulse Width HIGH	FO = 16	3.9	ns
		FO = 128	4.2	ns
t _{PWL}	Minimum Pulse Width LOW	FO = 16	3.9	ns
		FO = 128	4.2	ns
t _{CKSW}	Maximum Skew	FO = 16	0.7	ns
		FO = 128	0.9	ns
t _P	Minimum Period	FO = 16	8.3	ns
		FO = 128	8.7	ns
f _{MAX}	Maximum Frequency	FO = 16	120	MHz
		FO = 128	116	MHz
TTL Output Module Timing⁴				
t _{DLH}	Data-to-Pad HIGH		5.9	ns
t _{DHL}	Data-to-Pad LOW		7.1	ns
t _{ENZH}	Enable Pad Z to HIGH		6.7	ns
t _{ENZL}	Enable Pad Z to LOW		8.3	ns
t _{ENHZ}	Enable Pad HIGH to Z		14.1	ns
t _{ENLZ}	Enable Pad LOW to Z		10.4	ns
d _{TLH}	Delta LOW to HIGH		0.03	ns/pF
d _{THL}	Delta HIGH to LOW		0.05	ns/pF

Notes:

1. Routing delays are for typical designs across worst-case operating conditions. These parameters should be used for estimating device performance. Post-route timing analysis or simulation is required to determine actual performance.
2. Setup times assume a fanout of 3. Further testing information can be obtained from the Timer tool.
3. The hold time for the DFME1A macro may be greater than 0 ns. Use the Timer tool in Designer to check the hold time for this macro.
4. Delays based on 35 pF loading.

**Table 1-10 • A40MX04 Timing Characteristics (Nominal 5.0 V Operation)
Worst-Case Automotive Conditions, VCC = 4.75 V, TJ = 125°C**

Parameter	Description	Std. Speed		Units
		Min.	Max.	
Logic Module Propagation Delays¹				
t _{PD1}	Single Module		2.2	ns
t _{PD2}	Dual-Module Macros		4.7	ns
t _{CO}	Sequential Clock-to-Q		2.2	ns
t _{GO}	Latch G-to-Q		2.2	ns
t _{RS}	Flip-Flop (Latch) Reset-to-Q		2.2	ns
Logic Module Predicted Routing Delays¹				
t _{RD1}	FO=1 Routing Delay		2.4	ns
t _{RD2}	FO=2 Routing Delay		3.4	ns
t _{RD3}	FO=3 Routing Delay		4.3	ns
t _{RD4}	FO=4 Routing Delay		5.2	ns
t _{RD8}	FO=8 Routing Delay		9.0	ns
Logic Module Sequential Timing²				
t _{SUD}	Flip-Flop (Latch) Data Input Set-Up	5.4		ns
t _{HD} ³	Flip-Flop (Latch) Data Input Hold	0.0		ns
t _{SUENA}	Flip-Flop (Latch) Enable Set-Up	5.4		ns
t _{HENA}	Flip-Flop (Latch) Enable Hold	0.0		ns
t _{WCLKA}	Flip-Flop (Latch) Clock Active Pulse	5.8		ns
t _{WASYN}	Flip-Flop (Latch)	5.8		ns
t _A	Flip-Flop Clock Input Period	8.7		ns
f _{MAX}	Flip-Flop (Latch) Clock Frequency		116	MHz
Input Module Propagation Delays				
t _{INYH}	Pad-to-Y HIGH		1.3	ns
t _{INYL}	Pad-to-Y LOW		1.2	ns
Input Module Predicted Routing Delays¹				
t _{IRD1}	FO=1 Routing Delay		3.7	ns
t _{IRD2}	FO=2 Routing Delay		4.6	ns
t _{IRD3}	FO=3 Routing Delay		5.6	ns
t _{IRD4}	FO=4 Routing Delay		6.5	ns
t _{IRD8}	FO=8 Routing Delay		10.2	ns

Notes:

1. Routing delays are for typical designs across worst-case operating conditions. These parameters should be used for estimating device performance. Post-route timing analysis or simulation is required to determine actual performance.
2. Setup times assume a fanout of 3. Further testing information can be obtained from the Timer tool.
3. The hold time for the DFME1A macro may be greater than 0 ns. Use the Timer tool in Designer to check the hold time for this macro.
4. Delays based on 35 pF loading.

Table 1-10 • A40MX04 Timing Characteristics (Nominal 5.0 V Operation)
Worst-Case Automotive Conditions, VCC = 4.75 V, TJ = 125°C

Parameter	Description	Std. Speed		Units
		Min.	Max.	
Global Clock Network				
t _{CKH}	Input Low to HIGH	FO = 16	8.2	ns
		FO = 128	8.2	ns
t _{CKL}	Input High to LOW	FO = 16	8.7	ns
		FO = 128	8.7	ns
t _{PWH}	Minimum Pulse Width HIGH	FO = 16	3.9	ns
		FO = 128	4.2	ns
t _{PWL}	Minimum Pulse Width LOW	FO = 16	3.9	ns
		FO = 128	4.2	ns
t _{CKSW}	Maximum Skew	FO = 16	0.7	ns
		FO = 128	0.9	ns
t _P	Minimum Period	FO = 16	8.3	ns
		FO = 128	8.7	ns
f _{MAX}	Maximum Frequency	FO = 16	120	MHz
		FO = 128	116	MHz
TTL Output Module Timing⁴				
t _{DLH}	Data-to-Pad HIGH		5.9	ns
t _{DHL}	Data-to-Pad LOW		7.1	ns
t _{ENZH}	Enable Pad Z to HIGH		6.7	ns
t _{ENZL}	Enable Pad Z to LOW		8.3	ns
t _{ENHZ}	Enable Pad HIGH to Z		14.1	ns
t _{ENLZ}	Enable Pad LOW to Z		10.4	ns
d _{TLH}	Delta LOW to HIGH		0.03	ns/pF
d _{THL}	Delta HIGH to LOW		0.05	ns/pF

Notes:

1. Routing delays are for typical designs across worst-case operating conditions. These parameters should be used for estimating device performance. Post-route timing analysis or simulation is required to determine actual performance.
2. Setup times assume a fanout of 3. Further testing information can be obtained from the Timer tool.
3. The hold time for the DFME1A macro may be greater than 0 ns. Use the Timer tool in Designer to check the hold time for this macro.
4. Delays based on 35 pF loading.

**Table 1-12 • A42MX16 Timing Characteristics (Nominal 5.0 V Operation)
Worst-Case Automotive Conditions, VCCA = 4.75 V, T_J = 125°C**

Parameter	Description	Std. Speed		Units
		Min.	Max.	
Logic Module Propagation Delays ¹				
t _{PD1}	Single Module		2.2	ns
t _{CO}	Sequential Clock-to-Q		2.4	ns
t _{GO}	Latch G-to-Q		2.2	ns
t _{RS}	Flip-Flop (Latch) Reset-to-Q		2.6	ns
Logic Module Predicted Routing Delays ²				
t _{RD1}	FO=1 Routing Delay		1.3	ns
t _{RD2}	FO=2 Routing Delay		1.7	ns
t _{RD3}	FO=3 Routing Delay		2.1	ns
t _{RD4}	FO=4 Routing Delay		2.6	ns
t _{RD8}	FO=8 Routing Delay		4.3	ns
Logic Module Sequential Timing ^{3,4}				
t _{SUD}	Flip-Flop (Latch) Data Input Set-Up	0.6		ns
t _{HD}	Flip-Flop (Latch) Data Input Hold	0.0		ns
t _{SUENA}	Flip-Flop (Latch) Enable Set-Up	1.1		ns
t _{HENA}	Flip-Flop (Latch) Enable Hold	0.0		ns
t _{WCLKA}	Flip-Flop (Latch) Clock Active Pulse Width	5.6		ns
t _{WASYN}	Flip-Flop (Latch) Asynchronous Pulse Width	7.4		ns
t _A	Flip-Flop Clock Input Period	11.3		ns
t _{INH}	Input Buffer Latch Hold	0.0		ns
t _{INSU}	Input Buffer Latch Set-Up	0.8		ns
t _{OUTH}	Output Buffer Latch Hold	0.0		ns
t _{OUTSU}	Output Buffer Latch Set-Up	0.8		ns
f _{MAX}	Flip-Flop (Latch) Clock Frequency		139	MHz
Input Module Propagation Delays				
t _{INYH}	Pad-to-Y HIGH		1.8	ns
t _{INYL}	Pad-to-Y LOW		1.3	ns
t _{INGH}	G to Y HIGH		2.4	ns
t _{INGL}	G to Y LOW		2.4	ns

Notes:

1. For dual-module macros, use t_{PD1} + t_{RD1} + t_{PDn}, t_{CO} + t_{RD1} + t_{PDn}, or t_{PD1} + t_{RD1} + t_{SUD}, point and position whichever is appropriate.
2. Routing delays are for typical designs across worst-case operating conditions. These parameters should be used for estimating device performance. Post-route timing analysis or simulation is required to determine actual performance.
3. Data applies to macros based on the S-module. Timing parameters for sequential macros constructed from C-modules can be obtained from the Timer tool.
4. Setup and hold timing parameters for the input buffer latch are defined with respect to the PAD and the D input. External setup/hold timing parameters must account for delay from an external PAD signal to the G inputs. Delay from an external PAD signal to the G input subtracts (adds) to the internal setup (hold) time.
5. Delays based on 35 pF loading.

**Table 1-12 • A42MX16 Timing Characteristics (Nominal 5.0 V Operation)
 Worst-Case Automotive Conditions, VCCA = 4.75 V, T_J = 125°C**

Parameter	Description	Std. Speed		Units
		Min.	Max.	
Input Module Predicted Routing Delays²				
t _{IRD1}	FO=1 Routing Delay		3.0	ns
t _{IRD2}	FO=2 Routing Delay		3.5	ns
t _{IRD3}	FO=3 Routing Delay		3.9	ns
t _{IRD4}	FO=4 Routing Delay		4.4	ns
t _{IRD8}	FO=8 Routing Delay		6.1	ns
Global Clock Network				
t _{CKH}	Input Low to HIGH	FO = 32	4.4	ns
		FO = 384	4.8	ns
t _{CKL}	Input High to LOW	FO = 32	6.3	ns
		FO = 384	7.4	ns
t _{PWH}	Minimum Pulse Width HIGH	FO = 32	5.3	ns
		FO = 384	6.1	ns
t _{PWL}	Minimum Pulse Width LOW	FO = 32	5.3	ns
		FO = 384	6.1	ns
t _{CKSW}	Maximum Skew	FO = 32		0.6
		FO = 384		0.6
t _{SUEXT}	Input Latch External Setup	FO = 32	0.0	ns
		FO = 384	0.0	ns
t _{HEXT}	Input Latch External Hold	FO = 32	4.6	ns
		FO = 384	5.3	ns
t _P	Minimum Period	FO = 32	6.5	ns
		FO = 384	7.2	ns
f _{MAX}	Maximum Frequency	FO = 32		153
		FO = 384		139
TTL Output Module Timing⁵				
t _{DLH}	Data-to-Pad HIGH		4.2	ns
t _{DHL}	Data-to-Pad LOW		4.9	ns
t _{ENZH}	Enable Pad Z to HIGH		4.5	ns

Notes:

1. For dual-module macros, use $t_{PD1} + t_{RD1} + t_{PDn}$, $t_{CO} + t_{RD1} + t_{PDn}$, or $t_{PD1} + t_{RD1} + t_{SUD}$, point and position whichever is appropriate.
2. Routing delays are for typical designs across worst-case operating conditions. These parameters should be used for estimating device performance. Post-route timing analysis or simulation is required to determine actual performance.
3. Data applies to macros based on the S-module. Timing parameters for sequential macros constructed from C-modules can be obtained from the Timer tool.
4. Setup and hold timing parameters for the input buffer latch are defined with respect to the PAD and the D input. External setup/hold timing parameters must account for delay from an external PAD signal to the G inputs. Delay from an external PAD signal to the G input subtracts (adds) to the internal setup (hold) time.
5. Delays based on 35 pF loading.

**Table 1-12 • A42MX16 Timing Characteristics (Nominal 5.0 V Operation)
Worst-Case Automotive Conditions, VCCA = 4.75 V, T_J = 125°C**

Parameter	Description	Std. Speed		Units
		Min.	Max.	
t _{ENZL}	Enable Pad Z to LOW		4.9	ns
t _{ENHZ}	Enable Pad HIGH to Z		9.0	ns
t _{ENLZ}	Enable Pad LOW to Z		8.3	ns
t _{GLH}	G-to-Pad HIGH		4.8	ns
t _{GHL}	G-to-Pad LOW		4.8	ns
t _{LCO}	I/O Latch Clock-to-Out (Pad-to-Pad), 64 Clock Loading		9.4	ns
t _{ACO}	Array Clock-to-Out (Pad-to-Pad), 64 Clock Loading		13.3	ns
d _{TLH}	Capacity Loading, LOW to HIGH		0.04	ns/pF
d _{THL}	Capacity Loading, HIGH to LOW		0.06	ns/pF

Notes:

1. For dual-module macros, use $t_{PD1} + t_{RD1} + t_{PDn}$, $t_{CO} + t_{RD1} + t_{PDn}$, or $t_{PD1} + t_{RD1} + t_{SUD}$, point and position whichever is appropriate.
2. Routing delays are for typical designs across worst-case operating conditions. These parameters should be used for estimating device performance. Post-route timing analysis or simulation is required to determine actual performance.
3. Data applies to macros based on the S-module. Timing parameters for sequential macros constructed from C-modules can be obtained from the Timer tool.
4. Setup and hold timing parameters for the input buffer latch are defined with respect to the PAD and the D input. External setup/hold timing parameters must account for delay from an external PAD signal to the G inputs. Delay from an external PAD signal to the G input subtracts (adds) to the internal setup (hold) time.
5. Delays based on 35 pF loading.

**Table 1-13 • A42MX24 Timing Characteristics (Nominal 5.0 V Operation)
 Worst-Case Automotive Conditions, VCCA = 4.75 V, T_J = 125°C**

Parameter	Description	Std. Speed		Units
		Min.	Max.	
Logic Module Combinatorial Functions ¹				
t _{PD}	Internal Array Module Delay		2.0	ns
t _{PDD}	Internal Decode Module Delay		2.4	ns
Logic Module Predicted Routing Delays ²				
t _{RD1}	FO=1 Routing Delay		1.4	ns
t _{RD2}	FO=2 Routing Delay		1.7	ns
t _{RD3}	FO=3 Routing Delay		2.2	ns
t _{RD4}	FO=4 Routing Delay		2.5	ns
t _{RD8}	FO=8 Routing Delay		4.1	ns
Logic Module Sequential Timing ^{3, 4}				
t _{CO}	Flip-Flop Clock-to-Output		2.2	ns
t _{GO}	Latch Gate-to-Output		2.0	ns
t _{SUD}	Flip-Flop (Latch) Set-Up Time	0.6		ns
t _{HD}	Flip-Flop (Latch) Hold Time	0.0		ns
t _{RO}	Flip-Flop (Latch) Reset-to-Output		2.4	ns
t _{SUENA}	Flip-Flop (Latch) Enable Set-Up	0.7		ns
t _{HENA}	Flip-Flop (Latch) Enable Hold	0.0		ns
t _{WCLKA}	Flip-Flop (Latch) Clock Active Pulse Width	5.5		ns
t _{WASYN}	Flip-Flop (Latch) Asynchronous Pulse Width	7.4		ns
Input Module Propagation Delays				
t _{INPY}	Input Data Pad-to-Y		1.7	ns
t _{INGO}	Input Latch Gate-to-Output		2.2	ns
t _{INH}	Input Latch Hold	0.0		ns
t _{INSU}	Input Latch Set-Up	0.8		ns
t _{ILA}	Latch Active Pulse Width	7.8		ns

Notes:

1. For dual-module macros, use $t_{PD1} + t_{RD1} + t_{PDn}$, $t_{CO} + t_{RD1} + t_{PDn}$, or $t_{PD1} + t_{RD1} + t_{SUD}$, whichever is appropriate.
2. Routing delays are for typical designs across worst-case operating conditions. These parameters should be used for estimating device performance. Post-route timing analysis or simulation is required to determine actual performance.
3. Data applies to macros based on the S-module. Timing parameters for sequential macros constructed from C-modules can be obtained from the Timer tool.
4. Setup and hold timing parameters for the Input Buffer Latch are defined with respect to the PAD and the D input. External setup/hold timing parameters must account for delay from an external PAD signal to the G inputs. Delay from an external PAD signal to the G input subtracts (adds) to the internal setup (hold) time.
5. Delays based on 35 pF loading.

**Table 1-13 • A42MX24 Timing Characteristics (Nominal 5.0 V Operation)
Worst-Case Automotive Conditions, VCCA = 4.75 V, T_J = 125°C**

Parameter	Description	Std. Speed		Units
		Min.	Max.	
Input Module Predicted Routing Delays²				
t _{IRD1}	FO=1 Routing Delay		3.1	ns
t _{IRD2}	FO=2 Routing Delay		3.5	ns
t _{IRD3}	FO=3 Routing Delay		3.8	ns
t _{IRD4}	FO=4 Routing Delay		4.2	ns
t _{IRD8}	FO=8 Routing Delay		5.8	ns
Global Clock Network				
t _{CKH}	Input Low to HIGH	FO = 32	4.4	ns
		FO = 486	4.9	ns
t _{CKL}	Input High to LOW	FO = 32	6.1	ns
		FO = 486	7.1	ns
t _{PWH}	Minimum Pulse Width HIGH	FO = 32	3.6	ns
		FO = 486	4.0	ns
t _{PWL}	Minimum Pulse Width LOW	FO = 32	3.6	ns
		FO = 486	4.0	ns
t _{CKSW}	Maximum Skew	FO = 32	0.9	ns
		FO = 486	0.9	ns
t _{SUEXT}	Input Latch External Setup	FO = 32	0.0	ns
		FO = 486	0.0	ns
t _{HEXT}	Input Latch External Hold	FO = 32	4.6	ns
		FO = 486	5.5	ns
t _P	Minimum Period	FO = 32	7.4	ns
		FO = 486	8.0	ns
f _{MAX}	Maximum Frequency	FO = 32	135	MHz
		FO = 486	124	MHz

Notes:

1. For dual-module macros, use $t_{PD1} + t_{RD1} + t_{PDn}$, $t_{CO} + t_{RD1} + t_{PDn}$, or $t_{PD1} + t_{RD1} + t_{SUD}$, whichever is appropriate.
2. Routing delays are for typical designs across worst-case operating conditions. These parameters should be used for estimating device performance. Post-route timing analysis or simulation is required to determine actual performance.
3. Data applies to macros based on the S-module. Timing parameters for sequential macros constructed from C-modules can be obtained from the Timer tool.
4. Setup and hold timing parameters for the Input Buffer Latch are defined with respect to the PAD and the D input. External setup/hold timing parameters must account for delay from an external PAD signal to the G inputs. Delay from an external PAD signal to the G input subtracts (adds) to the internal setup (hold) time.
5. Delays based on 35 pF loading.

**Table 1-13 • A42MX24 Timing Characteristics (Nominal 5.0 V Operation)
 Worst-Case Automotive Conditions, VCCA = 4.75 V, T_J = 125°C**

Parameter	Description	Std. Speed		Units
		Min.	Max.	
TTL Output Module Timing⁵				
t _{DLH}	Data-to-Pad HIGH		4.1	ns
t _{DHL}	Data-to-Pad LOW		4.8	ns
t _{ENZH}	Enable Pad Z to HIGH		4.3	ns
t _{ENZL}	Enable Pad Z to LOW		4.8	ns
t _{ENHZ}	Enable Pad HIGH to Z		8.6	ns
t _{ENLZ}	Enable Pad LOW to Z		8.0	ns
t _{GLH}	G-to-Pad HIGH		4.9	ns
t _{GHL}	G-to-Pad LOW		4.9	ns
t _{LSU}	I/O Latch Set-Up	0.8		ns
t _{LH}	I/O Latch Hold	0.0		ns
t _{LCO}	I/O Latch Clock-to-Out (Pad-to-Pad), 64 Clock Loading		9.2	ns
t _{ACO}	Array Clock-to-Out (Pad-to-Pad), 64 Clock Loading		17.8	ns
d _{TLH}	Capacity Loading, LOW to HIGH		0.06	ns/pF
d _{THL}	Capacity Loading, HIGH to LOW		0.05	ns/pF

Notes:

1. For dual-module macros, use $t_{PD1} + t_{RD1} + t_{PDn}$, $t_{CO} + t_{RD1} + t_{PDn}$, or $t_{PD1} + t_{RD1} + t_{SUD}$, whichever is appropriate.
2. Routing delays are for typical designs across worst-case operating conditions. These parameters should be used for estimating device performance. Post-route timing analysis or simulation is required to determine actual performance.
3. Data applies to macros based on the S-module. Timing parameters for sequential macros constructed from C-modules can be obtained from the Timer tool.
4. Setup and hold timing parameters for the Input Buffer Latch are defined with respect to the PAD and the D input. External setup/hold timing parameters must account for delay from an external PAD signal to the G inputs. Delay from an external PAD signal to the G input subtracts (adds) to the internal setup (hold) time.
5. Delays based on 35 pF loading.

**Table 1-14 • A42MX36 Timing Characteristics (Nominal 5.0 V Operation)
Worst-Case Automotive Conditions, VCCA = 4.75 V, T_J = 125°C**

Parameter	Description	Std. Speed		Units
		Min.	Max.	
Logic Module Combinatorial Functions¹				
t _{PD}	Internal Array Module Delay		2.3	ns
t _{PDD}	Internal Decode Module Delay		2.7	ns
Logic Module Predicted Routing Delays²				
t _{RD1}	FO=1 Routing Delay		1.6	ns
t _{RD2}	FO=2 Routing Delay		2.2	ns
t _{RD3}	FO=3 Routing Delay		2.7	ns
t _{RD4}	FO=4 Routing Delay		3.3	ns
t _{RD8}	FO=8 Routing Delay		5.5	ns
t _{RDD}	Decode-to-Output Routing Delay		0.6	ns
Logic Module Sequential Timing^{3, 4}				
t _{CO}	Flip-Flop Clock-to-Output		2.2	ns
t _{GO}	Latch Gate-to-Output		2.2	ns
t _{SUD}	Flip-Flop (Latch) Set-Up Time	0.6		ns
t _{HD}	Flip-Flop (Latch) Hold Time	0.0		ns
t _{RO}	Flip-Flop (Latch) Reset-to-Output		2.6	ns
t _{SUENA}	Flip-Flop (Latch) Enable Set-Up	1.1		ns
t _{HENA}	Flip-Flop (Latch) Enable Hold	0.0		ns
t _{WCLKA}	Flip-Flop (Latch) Clock Active Pulse Width	5.5		ns
t _{WASYN}	Flip-Flop (Latch) Asynchronous Pulse Width	7.2		ns
Synchronous SRAM Operations				
t _{RC}	Read Cycle Time	11.3		ns
t _{WC}	Write Cycle Time	11.3		ns
t _{RCKHL}	Clock HIGH/LOW Time	5.7		ns
t _{RCO}	Data Valid After Clock HIGH/LOW		5.7	ns
t _{ADSU}	Address/Data Set-Up Time	2.7		ns
t _{ADH}	Address/Data Hold Time	0.0		ns
t _{RENSU}	Read Enable Set-Up	1.0		ns

Notes:

1. For dual-module macros, use $t_{PD1} + t_{RD1} + t_{PDn}$, $t_{CO} + t_{RD1} + t_{PDn}$, or $t_{PD1} + t_{RD1} + t_{SUD}$, whichever is appropriate.
2. Routing delays are for typical designs across worst-case operating conditions. These parameters should be used for estimating device performance. Post-route timing analysis or simulation is required to determine actual performance.
3. Data applies to macros based on the S-module. Timing parameters for sequential macros constructed from C-modules can be obtained from the Timer tool.
4. Setup and hold timing parameters for the Input Buffer Latch are defined with respect to the PAD and the D input. External setup/hold timing parameters must account for delay from an external PAD signal to the G inputs. Delay from an external PAD signal to the G input subtracts (adds) to the internal setup (hold) time.
5. Delays based on 35 pF loading.

Table 1-14 • A42MX36 Timing Characteristics (Nominal 5.0 V Operation)
Worst-Case Automotive Conditions, VCCA = 4.75 V, T_J = 125°C (continued)

Parameter	Description	Std. Speed		Units
		Min.	Max.	
t _{RENH}	Read Enable Hold	5.7		ns
t _{WENSU}	Write Enable Set-Up	4.5		ns
t _{WENH}	Write Enable Hold	0.0		ns
t _{BENS}	Block Enable Set-Up	4.6		ns
t _{BENH}	Block Enable Hold	0.0		ns
Asynchronous SRAM Operations				
t _{RPD}	Asynchronous Access Time		13.6	ns
t _{RDADV}	Read Address Valid	14.7		ns
t _{ADSU}	Address/Data Set-Up Time	2.7		ns
t _{ADH}	Address/Data Hold Time	0.0		ns
t _{RENSUA}	Read Enable Set-Up to Address Valid	1.0		ns
t _{RENHA}	Read Enable Hold	5.7		ns
t _{WENSU}	Write Enable Set-Up	4.5		ns
t _{WENH}	Write Enable Hold	0.0		ns
t _{DOH}	Data Out Hold Time		2.0	ns
Input Module Propagation Delays				
t _{INPY}	Input Data Pad-to-Y		1.7	ns
t _{INGO}	Input Latch Gate-to-Output		2.4	ns
t _{INH}	Input Latch Hold	0.0		ns
t _{INSU}	Input Latch Set-Up	0.8		ns
t _{ILA}	Latch Active Pulse Width	7.8		ns
Input Module Predicted Routing Delays²				
t _{IRD1}	FO=1 Routing Delay		3.3	ns
t _{IRD2}	FO=2 Routing Delay		3.8	ns
t _{IRD3}	FO=3 Routing Delay		4.4	ns
t _{IRD4}	FO=4 Routing Delay		5.0	ns
t _{IRD8}	FO=8 Routing Delay		7.2	ns
Global Clock Network				

Notes:

1. For dual-module macros, use $t_{PD1} + t_{RD1} + t_{PDn}$, $t_{CO} + t_{RD1} + t_{PDn}$, or $t_{PD1} + t_{RD1} + t_{SUD}$, whichever is appropriate.
2. Routing delays are for typical designs across worst-case operating conditions. These parameters should be used for estimating device performance. Post-route timing analysis or simulation is required to determine actual performance.
3. Data applies to macros based on the S-module. Timing parameters for sequential macros constructed from C-modules can be obtained from the Timer tool.
4. Setup and hold timing parameters for the Input Buffer Latch are defined with respect to the PAD and the D input. External setup/hold timing parameters must account for delay from an external PAD signal to the G inputs. Delay from an external PAD signal to the G input subtracts (adds) to the internal setup (hold) time.
5. Delays based on 35 pF loading.

**Table 1-14 • A42MX36 Timing Characteristics (Nominal 5.0 V Operation)
Worst-Case Automotive Conditions, VCCA = 4.75 V, T_J = 125°C (continued)**

Parameter	Description	Std. Speed		Units
		Min.	Max.	
t _{CKH}	Input Low to HIGH	FO = 32	4.5	ns
		FO = 635	5.0	ns
t _{CKL}	Input High to LOW	FO = 32	6.3	ns
		FO = 635	8.1	ns
t _{PWH}	Minimum Pulse Width HIGH	FO = 32	2.9	ns
		FO = 635	3.3	ns
t _{PWL}	Minimum Pulse Width LOW	FO = 32	2.9	ns
		FO = 635	3.3	ns
t _{CKSW}	Maximum Skew	FO = 32	1.1	ns
		FO = 635	1.1	ns
t _{SUEXT}	Input Latch External Setup	FO = 32	0.0	ns
		FO = 635	0.0	ns
t _{HEXT}	Input Latch External Hold	FO = 32	4.8	ns
		FO = 635	5.5	ns
t _P	Minimum Period	FO = 32	8.6	ns
		FO = 635	9.4	ns
f _{MAX}	Maximum Frequency	FO = 32	116	MHz
		FO = 635	107	MHz
TTL Output Module Timing¹				
t _{DLH}	Data-to-Pad HIGH		4.3	ns
t _{DHL}	Data-to-Pad LOW		5.0	ns
t _{ENZH}	Enable Pad Z to HIGH		4.4	ns
t _{ENZL}	Enable Pad Z to LOW		4.9	ns
t _{ENHZ}	Enable Pad HIGH to Z		8.8	ns
t _{ENLZ}	Enable Pad LOW to Z		8.3	ns
t _{GLH}	G-to-Pad HIGH		5.0	ns
t _{GHL}	G-to-Pad LOW		5.0	ns
t _{LSU}	I/O Latch Set-Up	0.8		ns

Notes:

1. For dual-module macros, use $t_{PD1} + t_{RD1} + t_{PDn}$, $t_{CO} + t_{RD1} + t_{PDn}$, or $t_{PD1} + t_{RD1} + t_{SUD}$, whichever is appropriate.
2. Routing delays are for typical designs across worst-case operating conditions. These parameters should be used for estimating device performance. Post-route timing analysis or simulation is required to determine actual performance.
3. Data applies to macros based on the S-module. Timing parameters for sequential macros constructed from C-modules can be obtained from the Timer tool.
4. Setup and hold timing parameters for the Input Buffer Latch are defined with respect to the PAD and the D input. External setup/hold timing parameters must account for delay from an external PAD signal to the G inputs. Delay from an external PAD signal to the G input subtracts (adds) to the internal setup (hold) time.
5. Delays based on 35 pF loading.

**Table 1-14 • A42MX36 Timing Characteristics (Nominal 5.0 V Operation)
Worst-Case Automotive Conditions, VCCA = 4.75 V, T_J = 125°C (continued)**

Parameter	Description	Std. Speed		Units
		Min.	Max.	
t _{LH}	I/O Latch Hold	0.0		ns
t _{LCO}	I/O Latch Clock-to-Out (Pad-to-Pad), 32 I/O		9.5	ns
t _{ACO}	Array Clock-to-Out (Pad-to-Pad), 32 I/O		13.0	ns
d _{TLH}	Capacity Loading, LOW to HIGH		0.11	ns/pF
d _{THL}	Capacity Loading, HIGH to LOW		0.11	ns/pF

Notes:

1. For dual-module macros, use $t_{PD1} + t_{RD1} + t_{PDn}$, $t_{CO} + t_{RD1} + t_{PDn}$, or $t_{PD1} + t_{RD1} + t_{SUD}$, whichever is appropriate.
2. Routing delays are for typical designs across worst-case operating conditions. These parameters should be used for estimating device performance. Post-route timing analysis or simulation is required to determine actual performance.
3. Data applies to macros based on the S-module. Timing parameters for sequential macros constructed from C-modules can be obtained from the Timer tool.
4. Setup and hold timing parameters for the Input Buffer Latch are defined with respect to the PAD and the D input. External setup/hold timing parameters must account for delay from an external PAD signal to the G inputs. Delay from an external PAD signal to the G input subtracts (adds) to the internal setup (hold) time.
5. Delays based on 35 pF loading.

**Table 1-11 • A42MX09 Timing Characteristics (Nominal 5.0 V Operation)
Worst-Case Automotive Conditions, VCCA = 4.75 V, T_J = 125°C**

Parameter	Description	Std. Speed		Units
		Min.	Max.	
Logic Module Propagation Delays ¹				
t _{PD1}	Single Module		2.0	ns
t _{CO}	Sequential Clock-to-Q		2.1	ns
t _{GO}	Latch G-to-Q		2.0	ns
t _{RS}	Flip-Flop (Latch) Reset-to-Q		2.4	ns
Logic Module Predicted Routing Delays ²				
t _{RD1}	FO=1 Routing Delay		1.1	ns
t _{RD2}	FO=2 Routing Delay		1.6	ns
t _{RD3}	FO=3 Routing Delay		1.9	ns
t _{RD4}	FO=4 Routing Delay		2.2	ns
t _{RD8}	FO=8 Routing Delay		3.8	ns
Logic Module Sequential Timing ^{3, 4}				

Notes:

1. For dual-module macros, use $t_{PD1} + t_{RD1} + t_{PDn}$, $t_{CO} + t_{RD1} + t_{PDn}$, or $t_{PD1} + t_{RD1} + t_{SUD}$, whichever is appropriate.
2. Routing delays are for typical designs across worst-case operating conditions. These parameters should be used for estimating device performance. Post-route timing analysis or simulation is required to determine actual performance.
3. Data applies to macros based on the S-module. Timing parameters for sequential macros constructed from C-modules can be obtained from the Timer tool.
4. Setup and hold timing parameters for the input buffer latch are defined with respect to the PAD and the D input. External setup/hold timing parameters must account for delay from an external PAD signal to the G inputs. Delay from an external PAD signal to the G input subtracts (adds) to the internal setup (hold) time.
5. Delays based on 35 pF loading.

**Table 1-11 • A42MX09 Timing Characteristics (Nominal 5.0 V Operation)
Worst-Case Automotive Conditions, VCCA = 4.75 V, T_J = 125°C**

Parameter	Description	Std. Speed		Units
		Min.	Max.	
t _{SUD}	Flip-Flop (Latch) Data Input Set-Up	0.4		ns
t _{HD}	Flip-Flop (Latch) Data Input Hold	0.0		ns
t _{SUENA}	Flip-Flop (Latch) Enable Set-Up	0.6		ns
t _{HENA}	Flip-Flop (Latch) Enable Hold	0.0		ns
t _{WCLKA}	Flip-Flop (Latch) Clock Active Pulse Width	4.8		ns
t _{WASYN}	Flip-Flop (Latch) Asynchronous Pulse Width	6.3		ns
t _A	Flip-Flop Clock Input Period	4.8		ns
t _{INH}	Input Buffer Latch Hold	0.0		ns
t _{INSU}	Input Buffer Latch Set-Up	0.4		ns
t _{OUTH}	Output Buffer Latch Hold	0.0		ns
t _{OUTSU}	Output Buffer Latch Set-Up	0.4		ns
f _{MAX}	Flip-Flop (Latch) Clock Frequency		174	MHz
Input Module Propagation Delays				
t _{INYH}	Pad-to-Y HIGH		1.8	ns
t _{INYL}	Pad-to-Y LOW		1.3	ns
t _{INGH}	G to Y HIGH		2.1	ns
t _{INGL}	G to Y LOW		2.1	ns
Input Module Predicted Routing Delays²				
t _{IRD1}	FO=1 Routing Delay		3.4	ns
t _{IRD2}	FO=2 Routing Delay		3.8	ns
t _{IRD3}	FO=3 Routing Delay		4.2	ns
t _{IRD4}	FO=4 Routing Delay		4.6	ns
t _{IRD8}	FO=8 Routing Delay		6.2	ns
Global Clock Network				
t _{CKH}	Input Low to HIGH	FO = 32	4.0	ns
		FO = 256	4.5	ns
t _{CKL}	Input High to LOW	FO = 32	5.8	ns
		FO = 256	6.4	ns
t _{PWH}	Minimum Pulse Width HIGH	FO = 32	2.0	ns

Notes:

- For dual-module macros, use $t_{PD1} + t_{RD1} + t_{PDn}$, $t_{CO} + t_{RD1} + t_{PDn}$, or $t_{PD1} + t_{RD1} + t_{SUD}$, whichever is appropriate.
- Routing delays are for typical designs across worst-case operating conditions. These parameters should be used for estimating device performance. Post-route timing analysis or simulation is required to determine actual performance.
- Data applies to macros based on the S-module. Timing parameters for sequential macros constructed from C-modules can be obtained from the Timer tool.
- Setup and hold timing parameters for the input buffer latch are defined with respect to the PAD and the D input. External setup/hold timing parameters must account for delay from an external PAD signal to the G inputs. Delay from an external PAD signal to the G input subtracts (adds) to the internal setup (hold) time.
- Delays based on 35 pF loading.

**Table 1-11 • A42MX09 Timing Characteristics (Nominal 5.0 V Operation)
 Worst-Case Automotive Conditions, VCCA = 4.75 V, T_J = 125°C**

Parameter	Description	Std. Speed		Units
		Min.	Max.	
t _{PWL}	Minimum Pulse Width LOW	FO = 256	2.2	ns
		FO = 32	2.0	ns
t _{CKSW}	Maximum Skew	FO = 256	2.2	ns
		FO = 32		0.6
t _{SUEXT}	Input Latch External Setup	FO = 256		0.6
		FO = 32	0.0	ns
t _{HEXT}	Input Latch External Hold	FO = 256	0.0	ns
		FO = 32	3.9	ns
t _P	Minimum Period	FO = 256	4.4	ns
		FO = 32	5.3	ns
f _{MAX}	Maximum Frequency	FO = 256	5.8	ns
		FO = 32		192
				174
TTL Output Module Timing⁵				
t _{DLH}	Data-to-Pad HIGH		4.0	ns
t _{DHL}	Data-to-Pad LOW		4.8	ns
t _{ENZH}	Enable Pad Z to HIGH		4.4	ns
t _{ENZL}	Enable Pad Z to LOW		4.8	ns
t _{ENHZ}	Enable Pad HIGH to Z		8.2	ns
t _{ENLZ}	Enable Pad LOW to Z		8.9	ns
t _{GLH}	G-to-Pad HIGH		4.3	ns
t _{GHL}	G-to-Pad LOW		4.3	ns
t _{LSU}	I/O Latch Set-Up	0.8		ns
t _{LH}	I/O Latch Hold	0.0		ns
t _{LCO}	I/O Latch Clock-to-Out (Pad-to-Pad), 64 Clock Loading		8.6	ns
t _{ACO}	Array Clock-to-Out (Pad-to-Pad), 64 Clock Loading		12.2	ns
d _{TLH}	Capacity Loading, LOW to HIGH		0.04	ns/pF
d _{THL}	Capacity Loading, HIGH to LOW		0.06	ns/pF

Notes:

1. For dual-module macros, use $t_{PD1} + t_{RD1} + t_{PDn}$, $t_{CO} + t_{RD1} + t_{PDn}$, or $t_{PD1} + t_{RD1} + t_{SUD}$, whichever is appropriate.
2. Routing delays are for typical designs across worst-case operating conditions. These parameters should be used for estimating device performance. Post-route timing analysis or simulation is required to determine actual performance.
3. Data applies to macros based on the S-module. Timing parameters for sequential macros constructed from C-modules can be obtained from the Timer tool.
4. Setup and hold timing parameters for the input buffer latch are defined with respect to the PAD and the D input. External setup/hold timing parameters must account for delay from an external PAD signal to the G inputs. Delay from an external PAD signal to the G input subtracts (adds) to the internal setup (hold) time.
5. Delays based on 35 pF loading.

Pin Descriptions

CLK/A/B, I/O **Global Clock**

Clock inputs for clock distribution networks. CLK is for 40MX while CLKA and CLKB are for 42MX devices. The clock input is buffered prior to clocking the logic modules. This pin can also be used as an I/O.

DCLK, I/O **Diagnostic Clock**

TTL clock input for diagnostic probe and device programming. DCLK is active when the MODE pin is HIGH. This pin functions as an I/O when the MODE pin is LOW.

GND **Ground**

Input LOW supply voltage.

I/O **Input/Output**

Input, output, tristate, or bidirectional buffer. Input and output levels are compatible with standard TTL specifications. Unused I/O pins are configured by the Designer software as shown in [Table 1-15](#).

Table 1-15 • Configuration of Unused I/Os

Device	Configuration
A40MX02, A40MX04	Pulled LOW
A42MX09, A42MX16	Pulled LOW
A42MX24, A42MX36	Tristated

In all cases, it is recommended to tie all unused I/O pins to LOW on the board. This applies to all dual-purpose pins when configured as I/Os as well.

MODE **Mode**

Controls the use of multifunction pins (DCLK, PRA, PRB, SDI, TDO). To provide verification capability, the MODE pin should be held HIGH. To facilitate this, the MODE pin should be tied to GND through a 10kΩ resistor so that the MODE pin can be pulled HIGH when required.

NC **No Connection**

This pin is not connected to circuitry within the device. These pins can be driven to any voltage or can be left floating with no effect on the operation of the device.

PRA/B, I/O **Probe**

The Probe pin is used to output data from any user-defined design node within the device. Each diagnostic pin can be used in conjunction with the other probe pin to allow real-time diagnostic output of any signal path within the device. The Probe pin can be used as a user-defined I/O when verification has been completed. The pin's probe capabilities can be permanently disabled to protect programmed design confidentiality. The Probe pin is accessible when the MODE pin is High. This pin functions as an I/O when the MODE pin is Low.

QCLKA,B,C,D, I/O **Quadrant Clock**

Quadrant clock inputs for A42MX36 devices. When not used as a register control signal, these pins can function as general-purpose I/Os.

SDI, I/O **Serial Data Input**

Serial data input for diagnostic probe and device programming. SDI is active when the MODE pin is High. This pin functions as an I/O when the MODE pin is Low.

SDO, TDO, I/O **Serial Data Output**

Serial data output for diagnostic probe and device programming. SDO is active when the MODE pin is High. This pin functions as an I/O when the MODE pin is Low. SDO is available for 42MX devices only.

When Silicon Explorer II is being used, SDO will act as an output while the "checksum" is run. It will return to user I/O when "checksum" is complete.

TCK, I/O Test Clock

Clock signal to shift the Boundary Scan Test (BST) data into the device. This pin functions as an I/O when "Reserve JTAG" is not checked in the Designer software. BST pins are only available in the A42MX24 and A42MX36 devices.

TDI, I/O Test Data In

Serial data input for BST instructions and data. Data is shifted in on the rising edge of TCK. This pin functions as an I/O when "Reserve JTAG" is not checked in the Designer software. BST pins are only available in the A42MX24 and A42MX36 devices.

TDO, I/O Test Data Out

Serial data output for BST instructions and test data. This pin functions as an I/O when "Reserve JTAG" is not checked in the Designer software. BST pins are only available in the A42MX24 and A42MX36 devices.

TMS, I/O Test Mode Select

The TMS pin controls the use of the IEEE 1149.1 Boundary Scan pins (TCK, TDI, TDO). In flexible mode when the TMS pin is set LOW, the TCK, TDI and TDO pins are boundary-scan pins. Once the boundary scan pins are in test mode, they will remain in that mode until the internal boundary scan state machine reaches the "logic reset" state. At this point, the boundary scan pins will be released and will function as regular I/O pins. The "logic reset" state is reached five TCK cycles after the TMS pin is set High. In dedicated test mode, TMS functions as specified in the IEEE 1149.1 specifications. IEEE JTAG specification recommends a 10kΩ pull-up resistor on the pin. BST pins are only available in A42MX24 and A42MX36 devices.

VCC Supply Voltage

Supply voltage for 40MX devices.

VCCA Supply Voltage

Supply voltage for array in 42MX devices.

VCCI Supply Voltage

Supply voltage for I/Os in 42MX devices.

WD, I/O Wide Decode Output

When a wide decode module is used in a an A42MX24 or A42MX36 device, this pin can be used as a dedicated output from the wide decode module. This direct connection eliminates additional interconnect delays associated with regular logic modules. To implement the direct I/O connection, connect an output buffer of any type to the output of the wide decode macro and place this output on one of the reserved WD pins. When a wide decode module is not used, this pin functions as a regular I/O pin.

2 – Package Pin Assignments

PL68

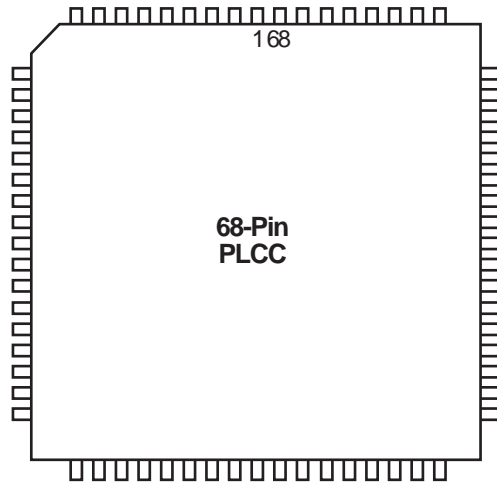

Note

For Package Manufacturing and Environmental information, visit Resource center at <http://www.microsemi.com/soc/products/rescenter/package/index.html>.

PL68	
Pin Number	A40MX02 Function
1	I/O
2	I/O
3	I/O
4	VCC
5	I/O
6	I/O
7	I/O
8	I/O
9	I/O
10	I/O
11	I/O
12	I/O
13	I/O
14	GND
15	GND
16	I/O
17	I/O
18	I/O
19	I/O
20	I/O
21	VCC
22	I/O
23	I/O
24	I/O
25	VCC
26	I/O
27	I/O
28	I/O
29	I/O
30	I/O
31	I/O
32	GND
33	I/O
34	I/O
35	I/O
36	I/O
37	I/O
38	VCC

PL68	
Pin Number	A40MX02 Function
39	I/O
40	I/O
41	I/O
42	I/O
43	I/O
44	I/O
45	I/O
46	I/O
47	I/O
48	I/O
49	GND
50	I/O
51	I/O
52	CLK, I/O
53	I/O
54	MODE
55	VCC
56	SDI, I/O
57	DCLK, I/O
58	PRA, I/O
59	PRB, I/O
60	I/O
61	I/O
62	I/O
63	I/O
64	I/O
65	I/O
66	GND
67	I/O
68	I/O

PL84

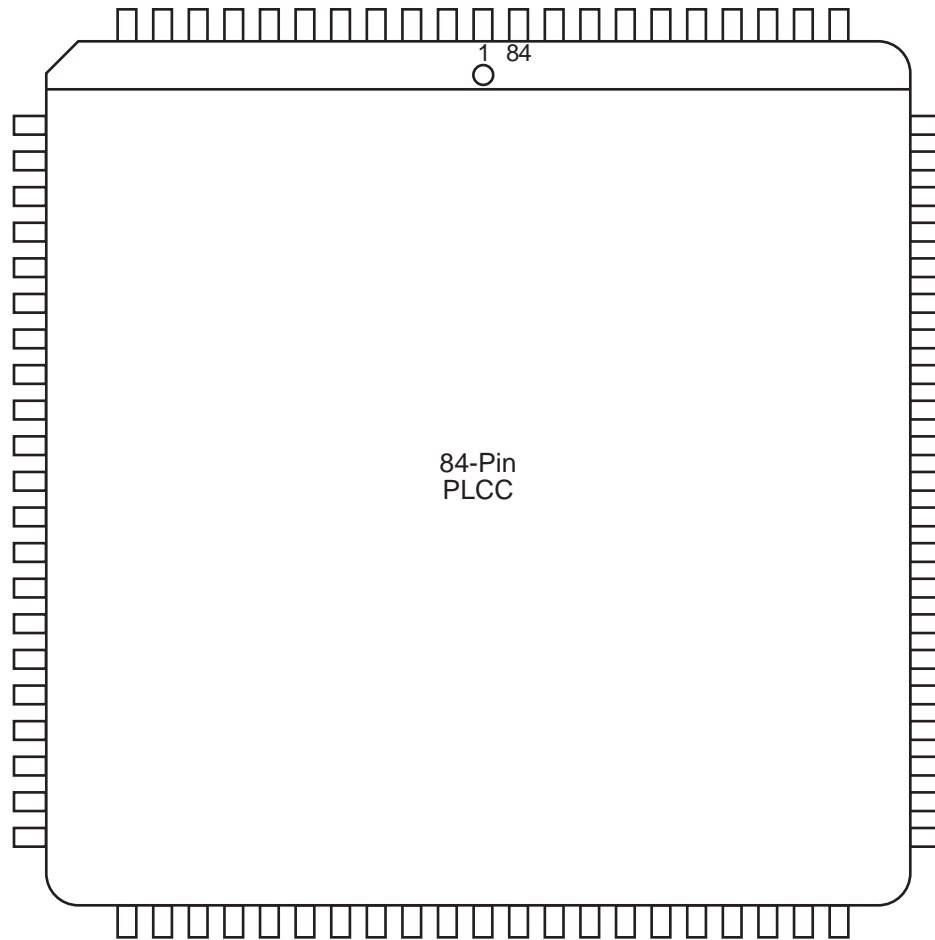

Note

For Package Manufacturing and Environmental information, visit Resource center at <http://www.microsemi.com/soc/products/rescenter/package/index.html>.

PL84		
Pin Number	A40MX04 Function	A42MX09 Function
1	I/O	I/O
2	I/O	CLKB, I/O
3	I/O	I/O
4	VCC	PRB, I/O
5	I/O	I/O
6	I/O	GND
7	I/O	I/O
8	I/O	I/O
9	I/O	I/O
10	I/O	DCLK, I/O
11	I/O	I/O
12	NC	MODE
13	I/O	I/O
14	I/O	I/O
15	I/O	I/O
16	I/O	I/O
17	I/O	I/O
18	GND	I/O
19	GND	I/O
20	I/O	I/O
21	I/O	I/O
22	I/O	VCCA
23	I/O	VCCI
24	I/O	I/O
25	VCC	I/O
26	VCC	I/O
27	I/O	I/O
28	I/O	GND
29	I/O	I/O
30	I/O	I/O
31	I/O	I/O
32	I/O	I/O
33	VCC	I/O
34	I/O	I/O
35	I/O	I/O
36	I/O	I/O
37	I/O	I/O
38	I/O	I/O
39	I/O	I/O
40	GND	I/O
41	I/O	I/O
42	I/O	I/O

PL84		
Pin Number	A40MX04 Function	A42MX09 Function
43	I/O	VCCA
44	I/O	I/O
45	I/O	I/O
46	VCC	I/O
47	I/O	I/O
48	I/O	I/O
49	I/O	GND
50	I/O	I/O
51	I/O	I/O
52	I/O	SDO, I/O
53	I/O	I/O
54	I/O	I/O
55	I/O	I/O
56	I/O	I/O
57	I/O	I/O
58	I/O	I/O
59	I/O	I/O
60	GND	I/O
61	GND	I/O
62	I/O	I/O
63	I/O	GND
64	CLK, I/O	VCCA
65	I/O	VCCI
66	MODE	I/O
67	VCC	I/O
68	VCC	I/O
69	I/O	I/O
70	I/O	GND
71	I/O	I/O
72	SDI, I/O	I/O
73	DCLK, I/O	I/O
74	PRA, I/O	I/O
75	PRB, I/O	I/O
76	I/O	SDI, I/O
77	I/O	I/O
78	I/O	I/O
79	I/O	I/O
80	I/O	I/O
81	I/O	PRA, I/O
82	GND	I/O
83	I/O	CLKA, I/O
84	I/O	VCCA

PQ100

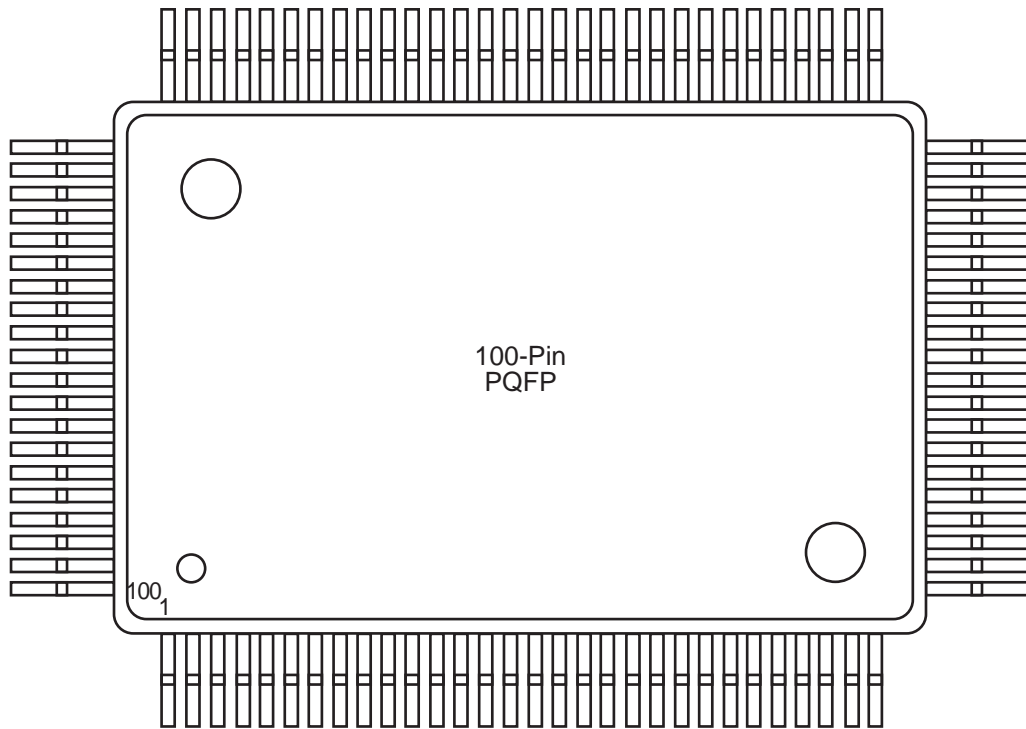

Note

For Package Manufacturing and Environmental information, visit Resource center at <http://www.microsemi.com/soc/products/rescenter/package/index.html>.

PQ100			
Pin Number	A40MX02 Function	A40MX04 Function	A42MX09 Function
1	NC	NC	I/O
2	NC	NC	DCLK, I/O
3	NC	NC	I/O
4	NC	NC	MODE
5	NC	NC	I/O
6	PRB, I/O	PRB, I/O	I/O
7	I/O	I/O	I/O
8	I/O	I/O	I/O
9	I/O	I/O	GND
10	I/O	I/O	I/O
11	I/O	I/O	I/O
12	I/O	I/O	I/O
13	GND	GND	I/O
14	I/O	I/O	I/O
15	I/O	I/O	I/O
16	I/O	I/O	VCCA
17	I/O	I/O	VCCI
18	I/O	I/O	I/O
19	VCC	VCC	I/O
20	I/O	I/O	I/O
21	I/O	I/O	I/O
22	I/O	I/O	GND
23	I/O	I/O	I/O
24	I/O	I/O	I/O
25	I/O	I/O	I/O
26	I/O	I/O	I/O
27	NC	NC	I/O
28	NC	NC	I/O
29	NC	NC	I/O
30	NC	NC	I/O
31	NC	I/O	I/O
32	NC	I/O	I/O
33	NC	I/O	I/O
34	I/O	I/O	GND
35	I/O	I/O	I/O

PQ100			
Pin Number	A40MX02 Function	A40MX04 Function	A42MX09 Function
36	GND	GND	I/O
37	GND	GND	I/O
38	I/O	I/O	I/O
39	I/O	I/O	I/O
40	I/O	I/O	VCCA
41	I/O	I/O	I/O
42	I/O	I/O	I/O
43	VCC	VCC	I/O
44	VCC	VCC	I/O
45	I/O	I/O	I/O
46	I/O	I/O	GND
47	I/O	I/O	I/O
48	NC	I/O	I/O
49	NC	I/O	I/O
50	NC	I/O	I/O
51	NC	NC	I/O
52	NC	NC	SDO, I/O
53	NC	NC	I/O
54	NC	NC	I/O
55	NC	NC	I/O
56	VCC	VCC	I/O
57	I/O	I/O	GND
58	I/O	I/O	I/O
59	I/O	I/O	I/O
60	I/O	I/O	I/O
61	I/O	I/O	I/O
62	I/O	I/O	I/O
63	GND	GND	I/O
64	I/O	I/O	GND
65	I/O	I/O	VCCA
66	I/O	I/O	VCCI
67	I/O	I/O	VCCA
68	I/O	I/O	I/O
69	VCC	VCC	I/O
70	I/O	I/O	I/O

PQ100			
Pin Number	A40MX02 Function	A40MX04 Function	A42MX09 Function
71	I/O	I/O	I/O
72	I/O	I/O	GND
73	I/O	I/O	I/O
74	I/O	I/O	I/O
75	I/O	I/O	I/O
76	I/O	I/O	I/O
77	NC	NC	I/O
78	NC	NC	I/O
79	NC	NC	SDI, I/O
80	NC	I/O	I/O
81	NC	I/O	I/O
82	NC	I/O	I/O
83	I/O	I/O	I/O
84	I/O	I/O	GND
85	I/O	I/O	I/O
86	GND	GND	I/O
87	GND	GND	PRA, I/O
88	I/O	I/O	I/O
89	I/O	I/O	CLKA, I/O
90	CLK, I/O	CLK, I/O	VCCA
91	I/O	I/O	I/O
92	MODE	MODE	CLKB, I/O
93	VCC	VCC	I/O
94	VCC	VCC	PRB, I/O
95	NC	I/O	I/O
96	NC	I/O	GND
97	NC	I/O	I/O
98	SDI, I/O	SDI, I/O	I/O
99	DCLK, I/O	DCLK, I/O	I/O
100	PRA, I/O	PRA, I/O	I/O

PQ160

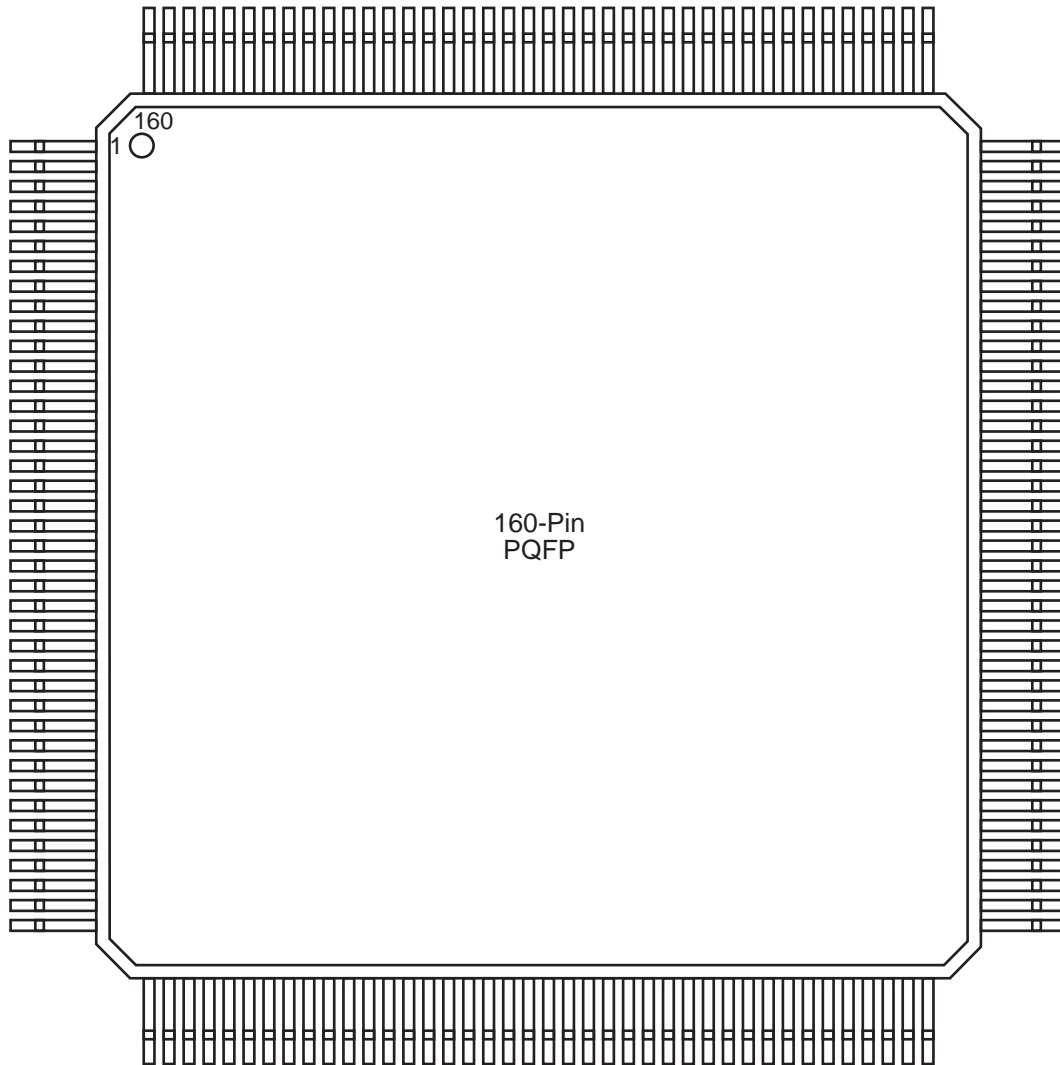

Note

For Package Manufacturing and Environmental information, visit Resource center at <http://www.microsemi.com/soc/products/rescenter/package/index.html>.

PQ160		
Pin Number	A42MX09 Function	A42MX24 Function
1	I/O	I/O
2	DCLK, I/O	DCLK, I/O
3	NC	I/O
4	I/O	WD, I/O
5	I/O	WD, I/O
6	NC	V _{CCI}
7	I/O	I/O
8	I/O	I/O
9	I/O	I/O
10	NC	I/O
11	GND	GND
12	NC	I/O
13	I/O	WD, I/O
14	I/O	WD, I/O
15	I/O	I/O
16	PRB, I/O	PRB, I/O
17	I/O	I/O
18	CLKB, I/O	CLKB, I/O
19	I/O	I/O
20	VCCA	VCCA
21	CLKA, I/O	CLKA, I/O
22	I/O	I/O
23	PRA, I/O	PRA, I/O
24	NC	WD, I/O
25	I/O	WD, I/O
26	I/O	I/O
27	I/O	I/O
28	NC	I/O
29	I/O	WD, I/O
30	GND	GND
31	NC	WD, I/O
32	I/O	I/O
33	I/O	I/O
34	I/O	I/O
35	NC	VCCI
36	I/O	WD, I/O
37	I/O	WD, I/O
38	SDI, I/O	SDI, I/O
39	I/O	I/O
40	GND	GND

PQ160		
Pin Number	A42MX09 Function	A42MX24 Function
41	I/O	I/O
42	I/O	I/O
43	I/O	I/O
44	GND	GND
45	I/O	I/O
46	I/O	I/O
47	I/O	I/O
48	I/O	I/O
49	GND	GND
50	I/O	I/O
51	I/O	I/O
52	NC	I/O
53	I/O	I/O
54	NC	VCCA
55	I/O	I/O
56	I/O	I/O
57	VCCA	VCCA
58	VCCI	VCCI
59	GND	GND
60	VCCA	VCCA
61	GND	GND
62	I/O	TCK, I/O
63	I/O	I/O
64	GND	GND
65	I/O	I/O
66	I/O	I/O
67	I/O	I/O
68	I/O	I/O
69	GND	GND
70	NC	I/O
71	I/O	I/O
72	I/O	I/O
73	I/O	I/O
74	I/O	I/O
75	NC	I/O
76	I/O	I/O
77	NC	I/O
78	I/O	I/O
79	NC	I/O
80	GND	GND

PQ160		
Pin Number	A42MX09 Function	A42MX24 Function
81	I/O	I/O
82	SDO, I/O	SDO, TDO, I/O
83	I/O	WD, I/O
84	I/O	WD, I/O
85	I/O	I/O
86	NC	VCCI
87	I/O	I/O
88	I/O	WD, I/O
89	GND	GND
90	NC	I/O
91	I/O	I/O
92	I/O	I/O
93	I/O	I/O
94	I/O	I/O
95	I/O	I/O
96	I/O	WD, I/O
97	I/O	I/O
98	VCCA	VCCA
99	GND	GND
100	NC	I/O
101	I/O	I/O
102	I/O	I/O
103	NC	I/O
104	I/O	I/O
105	I/O	I/O
106	I/O	WD, I/O
107	I/O	WD, I/O
108	I/O	I/O
109	GND	GND
110	NC	I/O
111	I/O	WD, I/O
112	I/O	WD, I/O
113	I/O	I/O
114	NC	VCCI
115	I/O	WD, I/O
116	NC	WD, I/O
117	I/O	I/O
118	I/O	TDI, I/O
119	I/O	TMS, I/O
120	GND	GND

PQ160		
Pin Number	A42MX09 Function	A42MX24 Function
121	I/O	I/O
122	I/O	I/O
123	I/O	I/O
124	NC	I/O
125	GND	GND
126	I/O	I/O
127	I/O	I/O
128	I/O	I/O
129	NC	I/O
130	GND	GND
131	I/O	I/O
132	I/O	I/O
133	I/O	I/O
134	I/O	I/O
135	NC	VCCA
136	I/O	I/O
137	I/O	I/O
138	NC	VCCA
139	VCCI	VCCI
140	GND	GND
141	NC	I/O
142	I/O	I/O
143	I/O	I/O
144	I/O	I/O
145	GND	GND
146	NC	I/O
147	I/O	I/O
148	I/O	I/O
149	I/O	I/O
150	NC	VCCA
151	NC	I/O
152	NC	I/O
153	NC	I/O
154	NC	I/O
155	GND	GND
156	I/O	I/O
157	I/O	I/O
158	I/O	I/O
159	MODE	MODE
160	GND	GND

VQ80

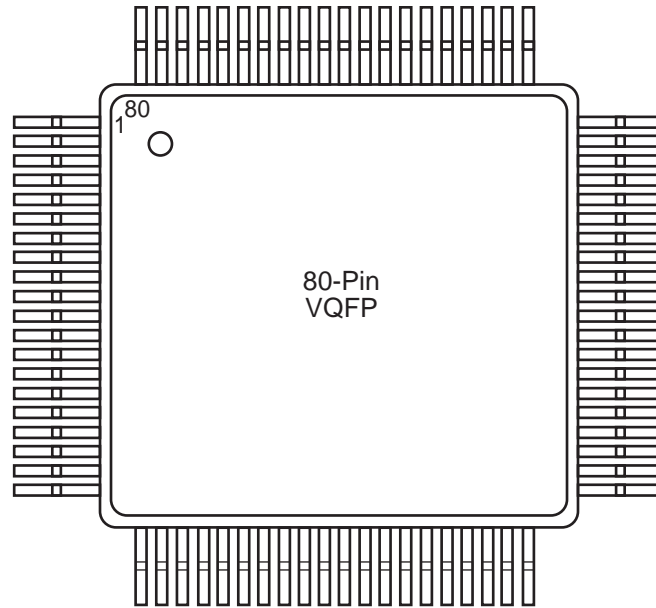

Note

For Package Manufacturing and Environmental information, visit Resource center at <http://www.microsemi.com/soc/products/rescenter/package/index.html>.

VQ80		
Pin Number	A40MX02 Function	A40MX04 Function
1	I/O	I/O
2	NC	I/O
3	NC	I/O
4	NC	I/O
5	I/O	I/O
6	I/O	I/O
7	GND	GND
8	I/O	I/O
9	I/O	I/O
10	I/O	I/O
11	I/O	I/O
12	I/O	I/O
13	VCC	VCC
14	I/O	I/O
15	I/O	I/O
16	I/O	I/O
17	NC	I/O
18	NC	I/O
19	NC	I/O
20	VCC	VCC
21	I/O	I/O
22	I/O	I/O
23	I/O	I/O
24	I/O	I/O
25	I/O	I/O
26	I/O	I/O
27	GND	GND
28	I/O	I/O
29	I/O	I/O
30	I/O	I/O
31	I/O	I/O
32	I/O	I/O
33	VCC	VCC
34	I/O	I/O
35	I/O	I/O
36	I/O	I/O
37	I/O	I/O
38	I/O	I/O
39	I/O	I/O
40	I/O	I/O
41	NC	I/O

VQ80		
Pin Number	A40MX02 Function	A40MX04 Function
42	NC	I/O
43	NC	I/O
44	I/O	I/O
45	I/O	I/O
46	I/O	I/O
47	GND	GND
48	I/O	I/O
49	I/O	I/O
50	CLK, I/O	CLK, I/O
51	I/O	I/O
52	MODE	MODE
53	VCC	VCC
54	NC	I/O
55	NC	I/O
56	NC	I/O
57	SDI, I/O	SDI, I/O
58	DCLK, I/O	DCLK, I/O
59	PRA, I/O	PRA, I/O
60	NC	NC
61	PRB, I/O	PRB, I/O
62	I/O	I/O
63	I/O	I/O
64	I/O	I/O
65	I/O	I/O
66	I/O	I/O
67	I/O	I/O
68	GND	GND
69	I/O	I/O
70	I/O	I/O
71	I/O	I/O
72	I/O	I/O
73	I/O	I/O
74	VCC	VCC
75	I/O	I/O
76	I/O	I/O
77	I/O	I/O
78	I/O	I/O
79	I/O	I/O
80	I/O	I/O

PQ208

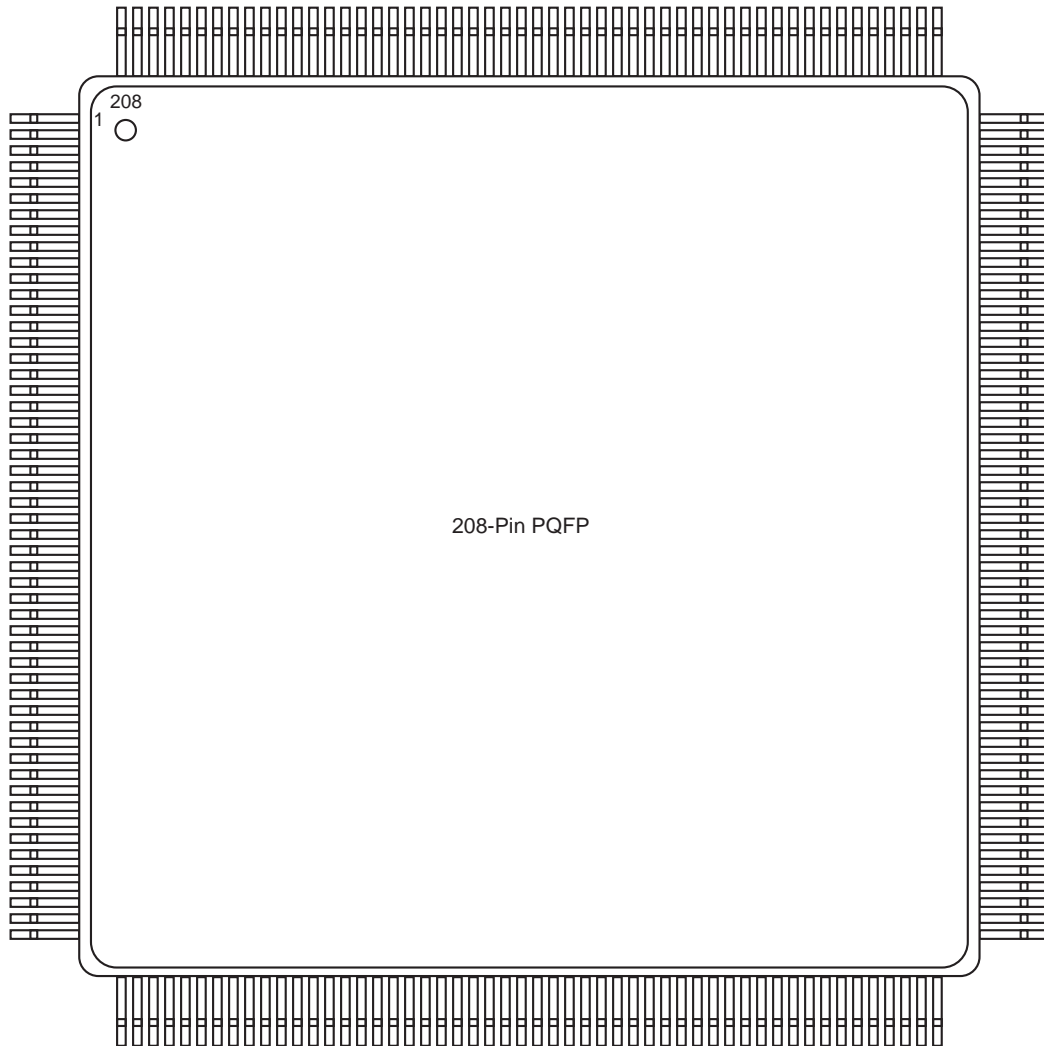

Note

For Package Manufacturing and Environmental information, visit Resource center at <http://www.microsemi.com/soc/products/rescenter/package/index.html>.

PQ208			
Pin Number	A42MX16 Function	A42MX24 Function	A42MX36 Function
1	GND	GND	GND
2	NC	VCCA	VCCA
3	MODE	MODE	MODE
4	I/O	I/O	I/O
5	I/O	I/O	I/O
6	I/O	I/O	I/O
7	I/O	I/O	I/O
8	I/O	I/O	I/O
9	NC	I/O	I/O
10	NC	I/O	I/O
11	NC	I/O	I/O
12	I/O	I/O	I/O
13	I/O	I/O	I/O
14	I/O	I/O	I/O
15	I/O	I/O	I/O
16	NC	I/O	I/O
17	VCCA	VCCA	VCCA
18	I/O	I/O	I/O
19	I/O	I/O	I/O
20	I/O	I/O	I/O
21	I/O	I/O	I/O
22	GND	GND	GND
23	I/O	I/O	I/O
24	I/O	I/O	I/O
25	I/O	I/O	I/O
26	I/O	I/O	I/O
27	GND	GND	GND
28	VCCI	VCCI	VCCI
29	VCCA	VCCA	VCCA
30	I/O	I/O	I/O
31	I/O	I/O	I/O
32	VCCA	VCCA	VCCA
33	I/O	I/O	I/O
34	I/O	I/O	I/O
35	I/O	I/O	I/O

PQ208			
Pin Number	A42MX16 Function	A42MX24 Function	A42MX36 Function
36	I/O	I/O	I/O
37	I/O	I/O	I/O
38	I/O	I/O	I/O
39	I/O	I/O	I/O
40	I/O	I/O	I/O
41	NC	I/O	I/O
42	NC	I/O	I/O
43	NC	I/O	I/O
44	I/O	I/O	I/O
45	I/O	I/O	I/O
46	I/O	I/O	I/O
47	I/O	I/O	I/O
48	I/O	I/O	I/O
49	I/O	I/O	I/O
50	NC	I/O	I/O
51	NC	I/O	I/O
52	GND	GND	GND
53	GND	GND	GND
54	I/O	TMS, I/O	TMS, I/O
55	I/O	TDI, I/O	TDI, I/O
56	I/O	I/O	I/O
57	I/O	WD, I/O	WD, I/O
58	I/O	WD, I/O	WD, I/O
59	I/O	I/O	I/O
60	VCCI	VCCI	VCCI
61	NC	I/O	I/O
62	NC	I/O	I/O
63	I/O	I/O	I/O
64	I/O	I/O	I/O
65	I/O	I/O	QCLKA, I/O
66	I/O	WD, I/O	WD, I/O
67	NC	WD, I/O	WD, I/O
68	NC	I/O	I/O
69	I/O	I/O	I/O
70	I/O	WD, I/O	WD, I/O

PQ208			
Pin Number	A42MX16 Function	A42MX24 Function	A42MX36 Function
71	I/O	WD, I/O	WD, I/O
72	I/O	I/O	I/O
73	I/O	I/O	I/O
74	I/O	I/O	I/O
75	I/O	I/O	I/O
76	I/O	I/O	I/O
77	I/O	I/O	I/O
78	GND	GND	GND
79	VCCA	VCCA	VCCA
80	NC	V _{CCI}	V _{CCI}
81	I/O	I/O	I/O
82	I/O	I/O	I/O
83	I/O	I/O	I/O
84	I/O	I/O	I/O
85	I/O	WD, I/O	WD, I/O
86	I/O	WD, I/O	WD, I/O
87	I/O	I/O	I/O
88	I/O	I/O	I/O
89	NC	I/O	I/O
90	NC	I/O	I/O
91	I/O	I/O	QCLKB, I/O
92	I/O	I/O	I/O
93	I/O	WD, I/O	WD, I/O
94	I/O	WD, I/O	WD, I/O
95	NC	I/O	I/O
96	NC	I/O	I/O
97	NC	I/O	I/O
98	VCCI	VCCI	VCCI
99	I/O	I/O	I/O
100	I/O	WD, I/O	WD, I/O
101	I/O	WD, I/O	WD, I/O
102	I/O	I/O	I/O
103	SDO, I/O	SDO, TDO, I/O	SDO, TDO, I/O
104	I/O	I/O	I/O
105	GND	GND	GND

PQ208			
Pin Number	A42MX16 Function	A42MX24 Function	A42MX36 Function
106	NC	V _{CCA}	V _{CCA}
107	I/O	I/O	I/O
108	I/O	I/O	I/O
109	I/O	I/O	I/O
110	I/O	I/O	I/O
111	I/O	I/O	I/O
112	NC	I/O	I/O
113	NC	I/O	I/O
114	NC	I/O	I/O
115	NC	I/O	I/O
116	I/O	I/O	I/O
117	I/O	I/O	I/O
118	I/O	I/O	I/O
119	I/O	I/O	I/O
120	I/O	I/O	I/O
121	I/O	I/O	I/O
122	I/O	I/O	I/O
123	I/O	I/O	I/O
124	I/O	I/O	I/O
125	I/O	I/O	I/O
126	GND	GND	GND
127	I/O	I/O	I/O
128	I/O	TCK, I/O	TCK, I/O
129	GND	GND	GND
130	VCCA	VCCA	VCCA
131	GND	GND	GND
132	V _{CCI}	V _{CCI}	V _{CCI}
133	VCCA	VCCA	VCCA
134	I/O	I/O	I/O
135	I/O	I/O	I/O
136	VCCA	VCCA	VCCA
137	I/O	I/O	I/O
138	I/O	I/O	I/O
139	I/O	I/O	I/O
140	I/O	I/O	I/O

PQ208			
Pin Number	A42MX16 Function	A42MX24 Function	A42MX36 Function
141	NC	I/O	I/O
142	I/O	I/O	I/O
143	I/O	I/O	I/O
144	I/O	I/O	I/O
145	I/O	I/O	I/O
146	NC	I/O	I/O
147	NC	I/O	I/O
148	NC	I/O	I/O
149	NC	I/O	I/O
150	GND	GND	GND
151	I/O	I/O	I/O
152	I/O	I/O	I/O
153	I/O	I/O	I/O
154	I/O	I/O	I/O
155	I/O	I/O	I/O
156	I/O	I/O	I/O
157	GND	GND	GND
158	I/O	I/O	I/O
159	SDI, I/O	SDI, I/O	SDI, I/O
160	I/O	I/O	I/O
161	I/O	WD, I/O	WD, I/O
162	I/O	WD, I/O	WD, I/O
163	I/O	I/O	I/O
164	VCCI	VCCI	VCCI
165	NC	I/O	I/O
166	NC	I/O	I/O
167	I/O	I/O	I/O
168	I/O	WD, I/O	WD, I/O
169	I/O	WD, I/O	WD, I/O
170	I/O	I/O	I/O
171	NC	I/O	QCLKD, I/O
172	I/O	I/O	I/O
173	I/O	I/O	I/O
174	I/O	I/O	I/O
175	I/O	I/O	I/O

PQ208			
Pin Number	A42MX16 Function	A42MX24 Function	A42MX36 Function
176	I/O	WD, I/O	WD, I/O
177	I/O	WD, I/O	WD, I/O
178	PRA, I/O	PRA, I/O	PRA, I/O
179	I/O	I/O	I/O
180	CLKA, I/O	CLKA, I/O	CLKA, I/O
181	NC	I/O	I/O
182	NC	VCCI	VCCI
183	VCCA	VCCA	VCCA
184	GND	GND	GND
185	I/O	I/O	I/O
186	CLKB, I/O	CLKB, I/O	CLKB, I/O
187	I/O	I/O	I/O
188	PRB, I/O	PRB, I/O	PRB, I/O
189	I/O	I/O	I/O
190	I/O	WD, I/O	WD, I/O
191	I/O	WD, I/O	WD, I/O
192	I/O	I/O	I/O
193	NC	I/O	I/O
194	NC	WD, I/O	WD, I/O
195	NC	WD, I/O	WD, I/O
196	I/O	I/O	QCLKC, I/O
197	NC	I/O	I/O
198	I/O	I/O	I/O
199	I/O	I/O	I/O
200	I/O	I/O	I/O
201	NC	I/O	I/O
202	VCCI	VCCI	VCCI
203	I/O	WD, I/O	WD, I/O
204	I/O	WD, I/O	WD, I/O
205	I/O	I/O	I/O
206	I/O	I/O	I/O
207	DCLK, I/O	DCLK, I/O	DCLK, I/O
208	I/O	I/O	I/O

PQ240



Note

For Package Manufacturing and Environmental information, visit Resource center at <http://www.microsemi.com/soc/products/rescenter/package/index.html>.

PQ240		PQ240		PQ240	
Pin Number	A42MX36 Function	Pin Number	A42MX36 Function	Pin Number	A42MX36 Function
1	I/O	42	I/O	83	I/O
2	DCLK, I/O	43	I/O	84	I/O
3	I/O	44	I/O	85	VCCA
4	I/O	45	QCLKD, I/O	86	I/O
5	I/O	46	I/O	87	I/O
6	WD, I/O	47	WD, I/O	88	VCCA
7	WD, I/O	48	WD, I/O	89	VCCI
8	V _{CCI}	49	I/O	90	VCCA
9	I/O	50	I/O	91	GND
10	I/O	51	I/O	92	TCK, I/O
11	I/O	52	VCCI	93	I/O
12	I/O	53	I/O	94	GND
13	I/O	54	WD, I/O	95	I/O
14	I/O	55	WD, I/O	96	I/O
15	QCLKC, I/O	56	I/O	97	I/O
16	I/O	57	SDI, I/O	98	I/O
17	WD, I/O	58	I/O	99	I/O
18	WD, I/O	59	VCCA	100	I/O
19	I/O	60	GND	101	I/O
20	I/O	61	GND	102	I/O
21	WD, I/O	62	I/O	103	I/O
22	WD, I/O	63	I/O	104	I/O
23	I/O	64	I/O	105	I/O
24	PRB, I/O	65	I/O	106	I/O
25	I/O	66	I/O	107	I/O
26	CLKB, I/O	67	I/O	108	VCCI
27	I/O	68	I/O	109	I/O
28	GND	69	I/O	110	I/O
29	VCCA	70	I/O	111	I/O
30	VCCI	71	V _{CCI}	112	I/O
31	I/O	72	I/O	113	I/O
32	CLKA, I/O	73	I/O	114	I/O
33	I/O	74	I/O	115	I/O
34	PRA, I/O	75	I/O	116	I/O
35	I/O	76	I/O	117	I/O
36	I/O	77	I/O	118	VCCA
37	WD, I/O	78	I/O	119	GND
38	WD, I/O	79	I/O	120	GND
39	I/O	80	I/O	121	GND
40	I/O	81	I/O	122	I/O
41	I/O	82	I/O	123	SDO, TDO, I/O

PQ240		PQ240		PQ240	
Pin Number	A42MX36 Function	Pin Number	A42MX36 Function	Pin Number	A42MX36 Function
124	I/O	165	I/O	206	VCCA
125	WD, I/O	166	QCLKA, I/O	207	I/O
126	WD, I/O	167	I/O	208	I/O
127	I/O	168	I/O	209	VCCA
128	VCCI	169	I/O	210	VCCI
129	I/O	170	I/O	211	I/O
130	I/O	171	I/O	212	I/O
131	I/O	172	VCCI	213	I/O
132	WD, I/O	173	I/O	214	I/O
133	WD, I/O	174	WD, I/O	215	I/O
134	I/O	175	WD, I/O	216	I/O
135	QCLKB, I/O	176	I/O	217	I/O
136	I/O	177	I/O	218	I/O
137	I/O	178	TDI, I/O	219	VCCA
138	I/O	179	TMS, I/O	220	I/O
139	I/O	180	GND	221	I/O
140	I/O	181	VCCA	222	I/O
141	I/O	182	GND	223	I/O
142	WD, I/O	183	I/O	224	I/O
143	WD, I/O	184	I/O	225	I/O
144	I/O	185	I/O	226	I/O
145	I/O	186	I/O	227	VCCI
146	I/O	187	I/O	228	I/O
147	I/O	188	I/O	229	I/O
148	I/O	189	I/O	230	I/O
149	I/O	190	I/O	231	I/O
150	VCCI	191	I/O	232	I/O
151	VCCA	192	VCCI	233	I/O
152	GND	193	I/O	234	I/O
153	I/O	194	I/O	235	I/O
154	I/O	195	I/O	236	I/O
155	I/O	196	I/O	237	GND
156	I/O	197	I/O	238	MODE
157	I/O	198	I/O	239	VCCA
158	I/O	199	I/O	240	GND
159	WD, I/O	200	I/O		
160	WD, I/O	201	I/O		
161	I/O	202	I/O		
162	I/O	203	I/O		
163	WD, I/O	204	I/O		
164	WD, I/O	205	I/O		

VQ100



Note

For Package Manufacturing and Environmental information, visit Resource center at <http://www.microsemi.com/soc/products/rescenter/package/index.html>.

VQ100			VQ100		
Pin Number	A42MX09 Function	A42MX16 Function	Pin Number	A42MX09 Function	A42MX16 Function
1	I/O	I/O	36	I/O	I/O
2	MODE	MODE	37	I/O	I/O
3	I/O	I/O	38	VCCA	VCCA
4	I/O	I/O	39	I/O	I/O
5	I/O	I/O	40	I/O	I/O
6	I/O	I/O	41	I/O	I/O
7	GND	GND	42	I/O	I/O
8	I/O	I/O	43	I/O	I/O
9	I/O	I/O	44	GND	GND
10	I/O	I/O	45	I/O	I/O
11	I/O	I/O	46	I/O	I/O
12	I/O	I/O	47	I/O	I/O
13	I/O	I/O	48	I/O	I/O
14	VCCA	NC	49	I/O	I/O
15	VCCI	VCCI	50	SDO, I/O	SDO, I/O
16	I/O	I/O	51	I/O	I/O
17	I/O	I/O	52	I/O	I/O
18	I/O	I/O	53	I/O	I/O
19	I/O	I/O	54	I/O	I/O
20	GND	GND	55	GND	GND
21	I/O	I/O	56	I/O	I/O
22	I/O	I/O	57	I/O	I/O
23	I/O	I/O	58	I/O	I/O
24	I/O	I/O	59	I/O	I/O
25	I/O	I/O	60	I/O	I/O
26	I/O	I/O	61	I/O	I/O
27	I/O	I/O	62	GND	GND
28	I/O	I/O	63	VCCA	VCCA
29	I/O	I/O	64	VCCI	VCCI
30	I/O	I/O	65	VCCA	VCCA
31	I/O	I/O	66	I/O	I/O
32	GND	GND	67	I/O	I/O
33	I/O	I/O	68	I/O	I/O
34	I/O	I/O	69	I/O	I/O
35	I/O	I/O	70	GND	GND

VQ100		
Pin Number	A42MX09 Function	A42MX16 Function
71	I/O	I/O
72	I/O	I/O
73	I/O	I/O
74	I/O	I/O
75	I/O	I/O
76	I/O	I/O
77	SDI, I/O	SDI, I/O
78	I/O	I/O
79	I/O	I/O
80	I/O	I/O
81	I/O	I/O
82	GND	GND
83	I/O	I/O
84	I/O	I/O
85	PRA, I/O	PRA, I/O
86	I/O	I/O
87	CLKA, I/O	CLKA, I/O
88	VCCA	VCCA
89	I/O	I/O
90	CLKB, I/O	CLKB, I/O
91	I/O	I/O
92	PRB, I/O	PRB, I/O
93	I/O	I/O
94	GND	GND
95	I/O	I/O
96	I/O	I/O
97	I/O	I/O
98	I/O	I/O
99	I/O	I/O
100	DCLK, I/O	DCLK, I/O

TQ176



Note

For Package Manufacturing and Environmental information, visit Resource center at <http://www.microsemi.com/soc/products/rescenter/package/index.html>.

TQ176			
Pin Number	A42MX09 Function	A42MX16 Function	A42MX24 Function
1	GND	GND	GND
2	MODE	MODE	MODE
3	I/O	I/O	I/O
4	I/O	I/O	I/O
5	I/O	I/O	I/O
6	I/O	I/O	I/O
7	I/O	I/O	I/O
8	NC	NC	I/O
9	I/O	I/O	I/O
10	NC	I/O	I/O
11	NC	I/O	I/O
12	I/O	I/O	I/O
13	NC	V _{CCA}	V _{CCA}
14	I/O	I/O	I/O
15	I/O	I/O	I/O
16	I/O	I/O	I/O
17	I/O	I/O	I/O
18	GND	GND	GND
19	NC	I/O	I/O
20	NC	I/O	I/O
21	I/O	I/O	I/O
22	NC	I/O	I/O
23	GND	GND	GND
24	NC	V _{CCI}	V _{CCI}
25	V _{CCA}	V _{CCA}	V _{CCA}
26	NC	I/O	I/O
27	NC	I/O	I/O
28	V _{CCI}	V _{CCA}	V _{CCA}
29	NC	I/O	I/O
30	I/O	I/O	I/O
31	I/O	I/O	I/O
32	I/O	I/O	I/O
33	NC	NC	I/O
34	I/O	I/O	I/O
35	I/O	I/O	I/O

TQ176			
Pin Number	A42MX09 Function	A42MX16 Function	A42MX24 Function
36	I/O	I/O	I/O
37	NC	I/O	I/O
38	NC	NC	I/O
39	I/O	I/O	I/O
40	I/O	I/O	I/O
41	I/O	I/O	I/O
42	I/O	I/O	I/O
43	I/O	I/O	I/O
44	I/O	I/O	I/O
45	GND	GND	GND
46	I/O	I/O	TMS, I/O
47	I/O	I/O	TDI, I/O
48	I/O	I/O	I/O
49	I/O	I/O	WD, I/O
50	I/O	I/O	WD, I/O
51	I/O	I/O	I/O
52	NC	V _{CCI}	V _{CCI}
53	I/O	I/O	I/O
54	NC	I/O	I/O
55	NC	I/O	WD, I/O
56	I/O	I/O	WD, I/O
57	NC	NC	I/O
58	I/O	I/O	I/O
59	I/O	I/O	WD, I/O
60	I/O	I/O	WD, I/O
61	NC	I/O	I/O
62	I/O	I/O	I/O
63	I/O	I/O	I/O
64	NC	I/O	I/O
65	I/O	I/O	I/O
66	NC	I/O	I/O
67	GND	GND	GND
68	V _{CCA}	V _{CCA}	V _{CCA}
69	I/O	I/O	WD, I/O
70	I/O	I/O	WD, I/O

TQ176			
Pin Number	A42MX09 Function	A42MX16 Function	A42MX24 Function
71	I/O	I/O	I/O
72	I/O	I/O	I/O
73	I/O	I/O	I/O
74	NC	I/O	I/O
75	I/O	I/O	I/O
76	I/O	I/O	I/O
77	NC	NC	WD, I/O
78	NC	I/O	WD, I/O
79	I/O	I/O	I/O
80	NC	I/O	I/O
81	I/O	I/O	I/O
82	NC	VCCI	VCCI
83	I/O	I/O	I/O
84	I/O	I/O	WD, I/O
85	I/O	I/O	WD, I/O
86	NC	I/O	I/O
87	SDO, I/O	SDO, I/O	SDO, TDO, I/O
88	I/O	I/O	I/O
89	GND	GND	GND
90	I/O	I/O	I/O
91	I/O	I/O	I/O
92	I/O	I/O	I/O
93	I/O	I/O	I/O
94	I/O	I/O	I/O
95	I/O	I/O	I/O
96	NC	I/O	I/O
97	NC	I/O	I/O
98	I/O	I/O	I/O
99	I/O	I/O	I/O
100	I/O	I/O	I/O
101	NC	NC	I/O
102	I/O	I/O	I/O
103	NC	I/O	I/O
104	I/O	I/O	I/O
105	I/O	I/O	I/O

TQ176			
Pin Number	A42MX09 Function	A42MX16 Function	A42MX24 Function
106	GND	GND	GND
107	NC	I/O	I/O
108	NC	I/O	TCK, I/O
109	LP	LP	LP
110	VCCA	VCCA	VCCA
111	GND	GND	GND
112	VCCI	VCCI	VCCI
113	VCCA	VCCA	VCCA
114	NC	I/O	I/O
115	NC	I/O	I/O
116	NC	VCCA	VCCA
117	I/O	I/O	I/O
118	I/O	I/O	I/O
119	I/O	I/O	I/O
120	I/O	I/O	I/O
121	NC	NC	I/O
122	I/O	I/O	I/O
123	I/O	I/O	I/O
124	NC	I/O	I/O
125	NC	I/O	I/O
126	NC	NC	I/O
127	I/O	I/O	I/O
128	I/O	I/O	I/O
129	I/O	I/O	I/O
130	I/O	I/O	I/O
131	I/O	I/O	I/O
132	I/O	I/O	I/O
133	GND	GND	GND
134	I/O	I/O	I/O
135	SDI, I/O	SDI, I/O	SDI, I/O
136	NC	I/O	I/O
137	I/O	I/O	WD, I/O
138	I/O	I/O	WD, I/O
139	I/O	I/O	I/O
140	NC	VCCI	VCCI

TQ176			
Pin Number	A42MX09 Function	A42MX16 Function	A42MX24 Function
141	I/O	I/O	I/O
142	I/O	I/O	I/O
143	NC	I/O	I/O
144	NC	I/O	WD, I/O
145	NC	NC	WD, I/O
146	I/O	I/O	I/O
147	NC	I/O	I/O
148	I/O	I/O	I/O
149	I/O	I/O	I/O
150	I/O	I/O	WD, I/O
151	NC	I/O	WD, I/O
152	PRA, I/O	PRA, I/O	PRA, I/O
153	I/O	I/O	I/O
154	CLKA, I/O	CLKA, I/O	CLKA, I/O
155	VCCA	VCCA	VCCA
156	GND	GND	GND
157	I/O	I/O	I/O
158	CLKB, I/O	CLKB, I/O	CLKB, I/O

TQ176			
Pin Number	A42MX09 Function	A42MX16 Function	A42MX24 Function
159	I/O	I/O	I/O
160	PRB, I/O	PRB, I/O	PRB, I/O
161	NC	I/O	WD, I/O
162	I/O	I/O	WD, I/O
163	I/O	I/O	I/O
164	I/O	I/O	I/O
165	NC	NC	WD, I/O
166	NC	I/O	WD, I/O
167	I/O	I/O	I/O
168	NC	I/O	I/O
169	I/O	I/O	I/O
170	NC	VCCI	VCCI
171	I/O	I/O	WD, I/O
172	I/O	I/O	WD, I/O
173	NC	I/O	I/O
174	I/O	I/O	I/O
175	DCLK, I/O	DCLK, I/O	DCLK, I/O
176	I/O	I/O	I/O

3 – Datasheet Information

List of Changes

The following table lists critical changes that were made in the current version of the document.

Revision	Changes in Current Version v3.1	Page
Revision 3 (May 2012)	The versioning system for datasheets has been changed. Datasheets are assigned a revision number that increments each time the datasheet is revised.	N/A
	The "Ordering Information" was revised to add a lead-free packaging ordering option (SARs 38327, 38329).	ii
	Package names used in "Product Profile" section, "Plastic Device Resources" section, and "Package Pin Assignments" section were revised to match standards given in <i>Package Mechanical Drawings</i> (SAR 34781).	i, ii, 2-1
	The "User Security" section was revised to clarify that although no existing security measures can give an absolute guarantee, Microsemi FPGAs implement the best security available in the industry (SAR 34667).	1-6
	The "Transient Current" section is new (SAR 38327).	1-7
	The "Development Tool Support" section is new (SAR 38481).	1-12
v3.1 (May 2006)	A note was added to the "Ordering Information".	ii
	Note 1 was added to "Recommended Operating Conditions".	1-13
v3.0 (April 2004)	The "Speed Grade and Temperature Grade Matrix" table is new.	ii
	The "Clock Networks" section was updated.	1-5
	The "I/O Modules" section was updated.	1-6
	The "Other Architectural Features" section is new.	1-6
	The "Development Tool Support" section was updated.	1-12
	The "Electrical Specifications" table was updated.	1-13
	The "Junction Temperature" section was updated.	1-17
	Table 1-6 was updated.	1-17
	Figure 1-14 and Figure 1-15 were updated.	1-18
	Figure 1-16 was updated.	1-19
	Figure 1-17 was updated.	1-20
	The "Critical Nets and Typical Nets" section was updated.	1-28
	The "Timing Derating" section is new.	1-28
	Table 1-7 and Figure 1-31 were updated.	1-29
	Table 1-8 and Figure 1-32 were updated.	1-30
All timing numbers contained in Table 1-9 through Table 1-14 were updated.	1-31 to 1-41	
The "Pin Descriptions" section was updated.	1-47	

Datasheet Categories

Categories

In order to provide the latest information to designers, some datasheet parameters are published before data has been fully characterized from silicon devices. The data provided for a given device is designated as either "Product Brief," "Advance," "Preliminary," or "Production." The definitions of these categories are as follows:

Product Brief

The product brief is a summarized version of a datasheet (advance or production) and contains general product information. This document gives an overview of specific device and family information.

Advance

This version contains initial estimated information based on simulation, other products, devices, or speed grades. This information can be used as estimates, but not for production. This label only applies to the DC and Switching Characteristics chapter of the datasheet and will only be used when the data has not been fully characterized.

Preliminary

The datasheet contains information based on simulation and/or initial characterization. The information is believed to be correct, but changes are possible.

Production

This version contains information that is considered to be final.

Export Administration Regulations (EAR)

The products described in this document are subject to the Export Administration Regulations (EAR). They could require an approved export license prior to export from the United States. An export includes release of product or disclosure of technology to a foreign national inside or outside the United States.

Safety Critical, Life Support, and High-Reliability Applications Policy

The products described in this advance status document may not have completed the Microsemi qualification process. Products may be amended or enhanced during the product introduction and qualification process, resulting in changes in device functionality or performance. It is the responsibility of each customer to ensure the fitness of any product (but especially a new product) for a particular purpose, including appropriateness for safety-critical, life-support, and other high-reliability applications. Consult the Microsemi SoC Products Group Terms and Conditions for specific liability exclusions relating to life-support applications. A reliability report covering all of the SoC Products Group's products is available at http://www.microsemi.com/soc/documents/ORT_Report.pdf. Microsemi also offers a variety of enhanced qualification and lot acceptance screening procedures. Contact your local sales office for additional reliability information.

