

ABP2 SERIES

32350268
Issue D

Board Mount Pressure Sensors

High Accuracy, Compensated/Amplified
6 mbar to 12 bar | 600 Pa to 1.2 MPa | 2 inH₂O to 175 psi
Digital or Analog Output, Liquid Media Capable

DESCRIPTION

The ABP2 Series are piezoresistive silicon pressure sensors offering a digital or analog output for reading pressure over the specified full scale pressure span and temperature range. They are calibrated and temperature compensated for sensor offset, sensitivity, temperature effects and accuracy errors (which include non-linearity, repeatability and hysteresis) using an on-board Application Specific Integrated Circuit (ASIC). Calibrated output values for pressure and temperature are updated at approximately 200 Hz. All products are designed and manufactured according to ISO 9001 standards. The liquid media option includes an additional gel coating to protect the electronics under port P1, which enables use with non-corrosive liquids (e.g. water and saline) and in applications where condensation can occur. The ABP2 Series is available in tube packaging. Pocket tape and reel packaging is available upon request.

VALUE TO CUSTOMERS

- Simplifies design-in: Small size saves room on the PC board (PCB), simplifying design in smaller and lower power devices. Meets IPC/JEDEC J-STD-020E Moisture Sensitivity Level 1 requirements:
 - Allows avoidance of thermal and mechanical damage during solder reflow attachment and/or repair that lesser rated sensors may incur.
 - Allows for unlimited shelf life when stored at <30°C/85 %RH (simplifying storage and reducing scrap).
 - Eliminates lengthy bakes prior to reflow.
 - Allows for lean manufacturing due to stability and usability shortly after reflow.
- Cost-effective: Small size helps engineers reduce design and manufacturing costs while maintaining enhanced performance and reliability of the systems they design.
- Accurate: Total Error Band (TEB) and wide pressure range enable engineers to optimize system performance by improving resolution and system accuracy.

- Flexible: Supply voltage range, variety of pressure units, types and ranges, output options, and wide operating temperature range simplify use in the application
- Versatile: Wet-media compatibility, low power, and temperature output options make the sensor a versatile choice for Internet of Things applications

DIFFERENTIATION

- Application-specific design ensures suitability for a wide array of customer requirements.
- Digital output allows the sensor to be directly plugged into the customer's circuitry without requiring major design changes
- Total Error Band (see Figure 1):
 - Provides a more comprehensive measurement of performance over the compensated temperature range, which minimizes testing and calibrating every sensor, thereby potentially reducing manufacturing cost; improves sensor accuracy and offers ease of sensor interchangeability due to minimal part-to-part variation.
 - Improves sensor accuracy
 - Offers ease of sensor interchangeability due to minimal part-to-part variation

POTENTIAL APPLICATIONS

- **Medical:** Ventilators/portable ventilators, CPAP, blood analysis, blood pressure monitoring, breast pumps, drug dosing, hospital beds, massage machines, oxygen concentrators, patient monitoring, sleep apnea equipment, urine analyzers and wound therapy
- **Industrial:** HVAC transmitters, life sciences, material handling, pneumatic control and regulation, process gas monitoring and valve positioning/positioners
- **Commercial:** Air beds, coffee makers, washing machines, level measurement, dish washers, vacuum cleaners, hand dryers and rice cookers
- **Transportation:** Air brakes, CNG monitoring, fork lifts and fuel level measurement



FEATURES

- Total Error Band (see Figure 1): As low as $\pm 1.5\%$ FSS
- Liquid media option: Compatible with a variety of liquid media
- Long-term stability: as low as $\pm 0.2\%$ FSS
- Accuracy: $\pm 0.25\%$ FSS BFLS
- Wide pressure range: 6 mbar to 12 bar | 600 Pa to 1.2 MPa | 2 inH₂O to 175 psi
- High burst pressures
- Wide operating temperature range of -40°C to 110°C [-40°F to 230°F]
- Calibrated over wide temperature range of -40°C to 110°C [-40°F to 230°F]
- 24-bit digital I²C or SPI-compatible output
- Ratiometric analog output
- IoT (Internet of Things) ready interface
- Ultra-low power consumption (as low as 0.01 mW typ. average power, 1 Hz measurement frequency)
- Meets IPC/JEDEC J-STD-020E Moisture Sensitivity Level 1
- REACH and RoHS compliant
- Temperature output available
- NSF-169, LFGB and BPA compliant materials



Honeywell offers a variety of board mount pressure sensors for use in potential medical and industrial applications. To view the entire product portfolio, [click here](#).

Honeywell

ABP2 SERIES BASIC BOARD MOUNT PRESSURE SENSORS

TABLE OF CONTENTS

| | |
|---|------------|
| TOTAL ERROR BAND | 3 |
| GENERAL SPECIFICATIONS | 4 |
| POWER CONSUMPTION AND STANDBY MODE | 7 |
| DIGITAL OUTPUT VERSIONS | 7 |
| ANALOG OUTPUT VERSIONS..... | 9 |
| NOMENCLATURE AND ORDER GUIDE | 10 |
| PRESSURE RANGE SPECIFICATIONS | 11 |
| DIMENSIONAL DRAWINGS | 19 |
| 1.0 GENERAL INFORMATION | 26 |
| 2.0 PINOUT AND FUNCTIONALITY | 26 |
| 3.0 START-UP TIMING..... | 26 |
| 4.0 POWER SUPPLY REQUIREMENT | 26 |
| 5.0 REFERENCE CIRCUIT DESIGNS..... | 27 |
| 5.1 DIGITAL OUTPUT VERSIONS | 27 |
| 5.2 ANALOG OUTPUT VERSIONS..... | 27 |
| 5.3 BYPASS CAPACITOR USE..... | 27 |
| 6.0 I ² C COMMUNICATIONS..... | 28 |
| 6.1 I ² C BUS CONFIGURATION | 28 |
| 6.2 I ² C DATA TRANSFER..... | 28 |
| 6.3 I ² C SENSOR ADDRESS | 28 |
| 6.4 I ² C PRESSURE AND TEMPERATURE READING..... | 28 |
| 6.5 I ² C STATUS BYTE | 29 |
| 6.6 I ² C COMMUNICATIONS..... | 29 |
| 6.7 I ² C TIMING AND LEVEL PARAMETERS | 30 |
| 6.8 REFERENCE CODE (ARDUINO/GENUINO UNO) FOR I ² C INTERFACE | 31 |
| 7.0 SPI COMMUNICATIONS | 32 |
| 7.1 SPI DEFINITION | 32 |
| 7.2 SPI DATA TRANSFER | 32 |
| 7.3 SPI PRESSURE AND TEMPERATURE READING..... | 32 |
| 7.4 SPI STATUS BYTE | 33 |
| 7.5 SPI COMMUNICATIONS..... | 34 |
| 7.6 SPI TIMING AND LEVEL PARAMETERS | 35 |
| 7.7 REFERENCE CODE (ARDUINO/GENUINO UNO) FOR SPI INTERFACE | 35 |
| 8.0 ABP2 SERIES CALCULATIONS..... | 36 |
| 8.1 DIGITAL OUTPUT VERSIONS | 36 |
| 8.2 ANALOG OUTPUT VERSIONS..... | 38 |
| 9.0 RECOMMENDED PNEUMATIC SENSOR CONNECTIONS | 39 |
| 9.1 TUBING | 39 |
| 9.2 O-RING MANIFOLD DESIGNS | 40 |
| ADDITIONAL INFORMATION | back cover |

ABP2 SERIES BASIC BOARD MOUNT PRESSURE SENSORS

TOTAL ERROR BAND

Total Error Band (TEB) is a single specification that includes the major sources of sensor error. TEB should not be confused with accuracy, which is actually a component of TEB. TEB is the worst error that the sensor could experience.

Honeywell uses the TEB specification in its datasheet because it is the most comprehensive measurement of a sensor’s true accuracy. Honeywell also provides the accuracy specification in order to provide a common comparison with competitors’ literature that does not use the TEB specification.

Many competitors do not use TEB—they simply specify the accuracy of their device. Their accuracy specification, however, may exclude certain parameters. On their datasheet, the errors are listed individually. When combined, the total error (or what would be TEB) could be significant.

FIGURE 1. TOTAL ERROR BAND

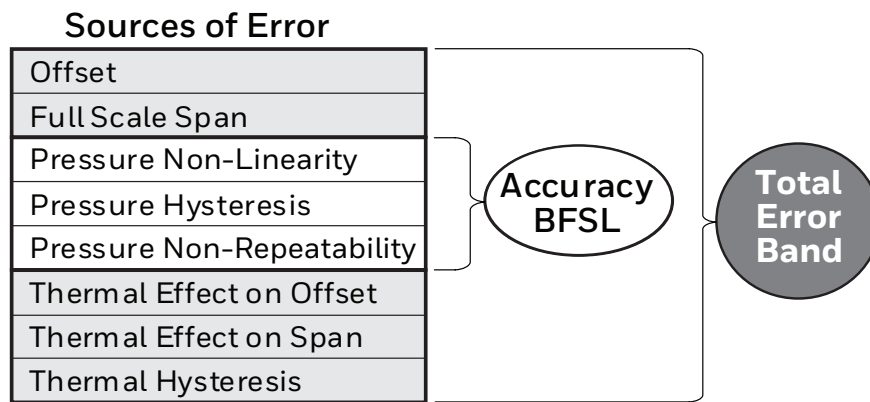

TABLE 1. ABSOLUTE MAXIMUM SPECIFICATIONS¹

| CHARACTERISTIC | MINIMUM | MAXIMUM | UNIT |
|---------------------------------------|----------------------------|--------------------|---------|
| Supply voltage (V_{supply}): | | | |
| digital output | -0.3 | 3.6 | Vdc |
| analog output | -0.3 | 6.0 | |
| Voltage on any pin | -0.3 | $V_{supply} + 0.3$ | Vdc |
| Digital clock frequency: | | | |
| I ² C | 100 | 400 | kHz |
| SPI | 50 | 800 | |
| ESD susceptibility (human body model) | 2 | — | kV |
| Storage temperature range | -40 [-40] | 125 [257] | °C [°F] |
| Soldering time and temperature: | | | |
| lead (DIP) | 4 s max. at 250°C [482°F] | | |
| peak reflow (SMT, Leadless SMT) | 15 s max. at 250°C [482°F] | | |

¹Absolute maximum ratings are the extreme limits the device will withstand without damage.

ABP2 SERIES BASIC BOARD MOUNT PRESSURE SENSORS

TABLE 2. OPERATING SPECIFICATIONS

| CHARACTERISTIC | ANALOG | | | DIGITAL | | | UNIT |
|---|-----------|---------|-----------|-----------|---------|-----------|-----------------------|
| | MINIMUM | TYPICAL | MAXIMUM | MINIMUM | TYPICAL | MAXIMUM | |
| Supply voltage (V_{supply}) ¹ | | | | | | | |
| 3.3 Vdc | 3.0 | 3.3 | 3.6 | 1.8 | 3.3 | 3.6 | Vdc |
| 5.0 Vdc | 4.75 | 5.0 | 5.25 | — | — | — | |
| Current consumption: | | | | | | | |
| I ² C sleep/standby mode | 3.0 | 33.8 | 211.0 | 3.0 | 33.8 | 211.0 | nA |
| SPI sleep/standby mode | 13.0 | 43.8 | 221.0 | 13.0 | 43.8 | 221.0 | |
| Power consumption | — | 9.5 | — | — | 3.1 | — | mW |
| Operating temperature range ² | -40 [-40] | — | 110 [230] | -40 [-40] | — | 110 [230] | °C [°F] |
| Compensated temperature range ³ | -40 [-40] | — | 110 [230] | -40 [-40] | — | 110 [230] | °C [°F] |
| Startup time ⁴ | — | — | 5 | — | — | 2.5 | ms |
| Clipping limit for analog version: | | | | | | | |
| upper | — | — | 97.5 | — | — | — | V_{supply} |
| lower | 2.5 | — | — | — | — | — | |
| Update/data rate | — | 1000 | — | 161 | 204 | — | samples/s |
| SPI/I ² C voltage level: | | | | | | | |
| low | — | — | — | — | — | 20 | % V_{supply} |
| high | — | — | — | 80 | — | — | |
| Pull up on SDA, SCL | — | — | — | 1 | — | — | kOhm |
| Total Error Band ⁵ : | | | | | | | |
| 0°C to 50°C | — | — | ±1.5 | — | — | ±1.5 | %FSS ⁶ |
| -20°C to 85°C | — | — | ±3.0 | — | — | ±3.0 | %FSS ⁶ |
| -40°C to 110°C | — | — | ±4.5 | — | — | ±4.5 | %FSS ⁶ |
| Accuracy ⁷ | — | — | ±0.25 | — | — | ±0.25 | %FSS BFSL |
| Resolution | 0.03 | — | — | — | — | — | %FSS bits |
| — | — | — | — | 14 | — | — | |
| Temperature output error ⁸ | — | — | — | — | ±5 | — | °C |

¹Sensors are not reverse polarity protected. Incorrect application of supply voltage or ground to the wrong pin may cause electrical failure.

²**Operating temperature range:** The temperature range over which the sensor will produce an output proportional to pressure.

³**Compensated temperature range:** The temperature range over which the sensor will produce an output proportional to pressure within the specified performance limits (see Total Error Band).

⁴**Startup Time:** For analog versions: 5 ms to data ready. For digital versions: 2.5 ms for power up to receive the first measurement command. Refer to Section 3.0, Tables 21, 22 and 25 for further details on communication timing.

⁵**Total Error Band:** The maximum deviation from the ideal transfer function over the entire compensated temperature and pressure range. Includes all errors due to offset, full scale span, pressure non-linearity, pressure hysteresis, repeatability, thermal effect on offset, thermal effect on span and thermal hysteresis.

⁶**Full Scale Span (FSS):** The algebraic difference between the output signal measured at the maximum (P_{max.}) and minimum (P_{min.}) limits of the pressure range (see Figure 2).

⁷**Accuracy:** The maximum deviation in output from a Best Fit Straight Line (BFSL) fitted to the output measured over the pressure range at 25°C [77°F]. Includes all errors due to pressure non-linearity, pressure hysteresis and non-repeatability.

⁸**Temperature Output Error:** The error in Temperature Output reading relative to a thermal reference standard over a temperature range of -40°C to 125°C.

ABP2 SERIES BASIC BOARD MOUNT PRESSURE SENSORS

TABLE 3. ENVIRONMENTAL SPECIFICATIONS

| CHARACTERISTIC | PARAMETER |
|---|--|
| Humidity: all external surfaces internal surfaces of liquid media options "T", "V", "G" and "F" internal surfaces of dry gases options "N" and "D" | 0 %RH to 95 %RH, non-condensing 0 %RH to 100 %RH, condensing 0 %RH to 95 %RH, non-condensing |
| Vibration | 15 g, 10 Hz to 2 kHz |
| Shock | 75 g, 6 ms duration |
| Life ¹ | 1 million full scale pressure cycles minimum |
| Solder reflow | J-STD-020-E Moisture Sensitivity Level 1 (unlimited shelf life when stored at ≤30°C/85 %RH) |
| Certification (silicone gel coating option, Port 1 only) ² | NSF169, BPA Free, LFGB |

¹Life may vary depending on specific application in which the sensor is utilized.

²Sensor materials have been tested and certified for the food safety standards noted.

TABLE 4. WETTED MATERIALS¹

| COMPONENT | PRESSURE PORT 1 (P1) | | PRESSURE PORT 2 (P2) |
|-----------------------|-------------------------------------|---|----------------------------|
| | DRY GAS OPTION | LIQUID MEDIA OPTION | |
| Ports and covers | high temperature polyamide, 304 SST | | high temperature polyamide |
| Substrate | FR4 | — | FR4 |
| Adhesives | epoxy, silicone | epoxy, silicone gel, fluorosilicone gel | epoxy, silicone |
| Electronic components | silicon, glass, gold, aluminum | — | silicon |

¹Contact Honeywell customer service for detailed material information.

TABLE 5. SENSOR PRESSURE TYPES

| PRESSURE TYPE | DESCRIPTION |
|---------------|---|
| Absolute | Output is proportional to the difference between pressure applied and a built-in vacuum reference. |
| Differential | Output is proportional to the difference between the applied pressure to each port (Port1 - Port2) |
| Gage | Output is proportional to the difference between applied pressure and atmospheric (ambient) pressure. |

TABLE 6. SENSOR OUTPUT AT SIGNIFICANT PERCENTAGES

| OUTPUT (%) | DIGITAL VERSIONS | | ANALOG VERSIONS | |
|------------|------------------|----------|---------------------|-------|
| | COUNTS | | V _{SUPPLY} | |
| | DECIMAL | HEX | 3.3 V | 5.0 V |
| 0 | 0 | 0X000000 | 0.0 | 0.0 |
| 10 | 1677722 | 0X19999A | 0.33 | 0.5 |
| 30 | 5033165 | 0X4CCCCC | 0.99 | 1.5 |
| 50 | 8388608 | 0X800000 | 1.65 | 2.5 |
| 70 | 11744051 | 0XB33333 | 2.31 | 3.5 |
| 90 | 15099494 | 0XE66666 | 2.97 | 4.5 |
| 100 | 16777215 | 0XFFFFFF | 3.3 | 5.0 |

ABP2 SERIES BASIC BOARD MOUNT PRESSURE SENSORS

FIGURE 2. TRANSFER FUNCTION FOR DIGITAL OUTPUT VERSIONS



Pressure example 1: Transfer Function A (10% to 90%)

$$\text{Output (\% of } 2^{24} \text{ counts)} = \frac{80\%}{P_{\text{max.}} - P_{\text{min.}}} \times (\text{Pressure}_{\text{applied}} - P_{\text{min.}}) + 10\%$$

Pressure example 2: Transfer Function B (30% to 70%)

$$\text{Output (\% of } 2^{24} \text{ counts)} = \frac{40\%}{P_{\text{max.}} - P_{\text{min.}}} \times (\text{Pressure}_{\text{applied}} - P_{\text{min.}}) + 30\%$$

FIGURE 3. TRANSFER FUNCTION FOR ANALOG OUTPUT VERSIONS



$$\text{Output (V)} = \frac{0.8 \times V_{\text{supply}}}{P_{\text{max.}} - P_{\text{min.}}} \times (\text{Pressure}_{\text{applied}} - P_{\text{min.}}) + 0.10 \times V_{\text{supply}}$$

ABP2 SERIES BASIC BOARD MOUNT PRESSURE SENSORS

POWER CONSUMPTION AND STANDBY MODE

DIGITAL OUTPUT VERSIONS

The sensor is normally in Standby Mode and is only turned on in response to a user command, thus minimizing power consumption. Upon receiving the user command, the sensor wakes up from Standby Mode, runs a measurement in Active State, and automatically returns to Standby Mode, awaiting the next command. The resulting sensor power consumption is a function of the sampling rate (samples per second) as shown in Tables 7 and 8 and Figures 4 and 5.

TABLE 7. DIGITAL OUTPUT VERSIONS AVERAGE POWER CONSUMPTION AT 1.8 V_{SUPPLY} (ASSUMES COMMAND AA_{HEX})

| SAMPLING RATE (samples per second) | AVERAGE POWER (mW) | ACTIVE TIME (ms) | ACTIVE POWER (mW) | IDLE TIME (ms) | IDLE POWER (mW) |
|---------------------------------------|-----------------------|---------------------|----------------------|-------------------|--------------------|
| Minimum Average Power | | | | | |
| 1 | 0.0068 | 3.625 | 1.884 | 996.375 | 0.0000054 |
| 2 | 0.0137 | 7.25 | 1.884 | 992.75 | 0.0000054 |
| 5 | 0.0341 | 18.125 | 1.884 | 981.875 | 0.0000054 |
| 10 | 0.0683 | 36.25 | 1.884 | 963.75 | 0.0000054 |
| 20 | 0.1366 | 72.5 | 1.884 | 927.5 | 0.0000054 |
| 50 | 0.3414 | 181.25 | 1.884 | 818.75 | 0.0000054 |
| 100 | 0.6829 | 362.5 | 1.884 | 637.5 | 0.0000054 |
| 160 | 1.0926 | 580 | 1.884 | 420 | 0.0000054 |
| Typical Average Power | | | | | |
| 1 | 0.0094 | 4.157 | 2.248 | 995.843 | 0.00006084 |
| 2 | 0.0187 | 8.314 | 2.248 | 991.686 | 0.00006084 |
| 5 | 0.0468 | 20.785 | 2.248 | 979.215 | 0.00006084 |
| 10 | 0.0935 | 41.57 | 2.248 | 958.43 | 0.00006084 |
| 20 | 0.1870 | 83.14 | 2.248 | 916.86 | 0.00006084 |
| 50 | 0.4673 | 207.85 | 2.248 | 792.15 | 0.00006084 |
| 100 | 0.9345 | 415.7 | 2.248 | 584.3 | 0.00006084 |
| 160 | 1.4592 | 665.12 | 2.248 | 334.88 | 0.00006084 |
| Maximum Average Power | | | | | |
| 1 | 0.0129 | 4.839 | 2.588 | 995.161 | 0.0003798 |
| 2 | 0.0254 | 9.678 | 2.588 | 990.322 | 0.0003798 |
| 5 | 0.0630 | 24.195 | 2.588 | 975.805 | 0.0003798 |
| 10 | 0.1256 | 48.39 | 2.588 | 951.61 | 0.0003798 |
| 20 | 0.2508 | 96.78 | 2.588 | 903.22 | 0.0003798 |
| 50 | 0.6264 | 241.95 | 2.588 | 758.05 | 0.0003798 |
| 100 | 1.2524 | 483.9 | 2.588 | 516.1 | 0.0003798 |
| 160 | 2.0036 | 774.24 | 2.588 | 225.76 | 0.0003798 |

FIGURE 4. DIGITAL OUTPUT VERSIONS AVERAGE POWER CONSUMPTION VS SAMPLING RATE AT 1.8 V_{SUPPLY}



ABP2 SERIES BASIC BOARD MOUNT PRESSURE SENSORS

TABLE 8 . DIGITAL OUTPUT VERSIONS AVERAGE POWER CONSUMPTION AT 3.3 V_{SUPPLY} (ASSUMES COMMAND AA_{HEX})

| SAMPLING RATE (samples per second) | AVERAGE POWER (mW) | ACTIVE TIME (ms) | ACTIVE POWER (mW) | IDLE TIME (ms) | IDLE POWER (mW) |
|---------------------------------------|-----------------------|---------------------|----------------------|-------------------|--------------------|
| Minimum Average Power | | | | | |
| 1 | 0.0114 | 3.625 | 3.134 | 996.375 | 0.0000099 |
| 2 | 0.0227 | 7.25 | 3.134 | 992.75 | 0.0000099 |
| 5 | 0.0568 | 18.125 | 3.134 | 981.875 | 0.0000099 |
| 10 | 0.1136 | 36.25 | 3.134 | 963.75 | 0.0000099 |
| 20 | 0.2272 | 72.5 | 3.134 | 927.5 | 0.0000099 |
| 50 | 0.5680 | 181.25 | 3.134 | 818.75 | 0.0000099 |
| 100 | 1.1361 | 362.5 | 3.134 | 637.5 | 0.0000099 |
| 160 | 1.8177 | 580 | 3.134 | 420 | 0.0000099 |
| Typical Average Power | | | | | |
| 1 | 0.0156 | 4.157 | 3.729 | 995.843 | 0.00011154 |
| 2 | 0.0311 | 8.314 | 3.729 | 991.686 | 0.00011154 |
| 5 | 0.0776 | 20.785 | 3.729 | 979.215 | 0.00011154 |
| 10 | 0.1551 | 41.57 | 3.729 | 958.43 | 0.00011154 |
| 20 | 0.3101 | 83.14 | 3.729 | 916.86 | 0.00011154 |
| 50 | 0.7751 | 207.85 | 3.729 | 792.15 | 0.00011154 |
| 100 | 1.5501 | 415.7 | 3.729 | 584.3 | 0.00011154 |
| 160 | 2.4800 | 665.12 | 3.729 | 334.88 | 0.00011154 |
| Maximum Average Power | | | | | |
| 1 | 0.0214 | 4.839 | 4.275 | 995.161 | 0.0006963 |
| 2 | 0.0421 | 9.678 | 4.275 | 990.322 | 0.0006963 |
| 5 | 0.1041 | 24.195 | 4.275 | 975.805 | 0.0006963 |
| 10 | 0.2075 | 48.39 | 4.275 | 951.61 | 0.0006963 |
| 20 | 0.4144 | 96.78 | 4.275 | 903.22 | 0.0006963 |
| 50 | 1.0349 | 241.95 | 4.275 | 758.05 | 0.0006963 |
| 100 | 2.0692 | 483.9 | 4.275 | 516.1 | 0.0006963 |
| 160 | 3.3103 | 774.24 | 4.275 | 225.76 | 0.0006963 |

FIGURE 5. DIGITAL OUPUT VERSIONS AVERAGE POWER CONSUMPTION VS SAMPLING RATE AT 3.3 V_{SUPPLY}



ABP2 SERIES BASIC BOARD MOUNT PRESSURE SENSORS

ANALOG OUTPUT VERSIONS (SEE TABLE 9 AND FIGURE 6.)

| TABLE 9. ANALOG OUTPUT VERSIONS POWER CONSUMPTION | | | | |
|---|-------------------|--------------------|--------------------|--------------------|
| V _{SUPPLY} (V) | ACTIVE POWER (mW) | MINIMUM POWER (mW) | AVERAGE POWER (mW) | MAXIMUM POWER (mW) |
| 2.8 | 3.36 | 3.3 | 3.4 | 3.5 |
| 3.3 | 4.62 | 4.4 | 4.5 | 4.7 |
| 5 | 9.5 | 9.1 | 9.2 | 9.4 |
| 5.5 | 11 | 10.9 | 11.0 | 11.1 |

FIGURE 6. ANALOG OUTPUT VERSIONS AVERAGE POWER CONSUMPTION



ABP2 SERIES BASIC BOARD MOUNT PRESSURE SENSORS

FIGURE 7. NOMENCLATURE AND ORDER GUIDE

For example, **ABP2DANT001BA2A3XX** defines an ABP2 Series Amplified Basic Pressure Sensor, DIP package, plastic single axial barbed pressure port, liquid media, food-grade silicone gel, no diagnostics, 1 bar absolute pressure range, digital I²C, address 0x28 output type, 10% to 90% of 2²⁴ counts (digital) transfer function, 3.3 Vdc supply voltage.

ABP2 D AN T 001BA 2 A 3 XX

Product Series

ABP2 Amplified Basic

Package

D DIP (Dual Inline Pin)

M SMT (Surface Mount Technology)

L Leadless SMT

Pressure Port¹

| | DIP | SMT | Leadless SMT |
|----------------|---|---|---|
| Plastic | NN No port | NN No port | NN No port |
| | AN Single axial barbed port | AN Single axial barbed port | AN Single axial barbed port |
| | VN Single axial barbless port | VN Single axial barbless port | VN Single axial barbless port |
| Metal | SN Single axial straight barbless port | SN Single axial straight barbless port | SN Single axial straight barbless port |
| | RN Single radial barbed port | RN Single radial barbed port | — |
| Plastic | RR Dual radial barbed ports, same side | RR Dual radial barbed ports, same side | — |
| | DA Dual axial barbed ports, same side | DA Dual axial barbed ports, same side | — |

Product Option^{2,3,4}

| | |
|----------|---|
| N | Dry gases only, no diagnostics |
| D | Dry gases only, diagnostics on |
| T | Liquid media, food-grade silicone gel, no diagnostics |
| V | Liquid media, food-grade silicone gel, diagnostics on |
| G | Liquid media, fluorosilicone gel, no diagnostics |
| F | Liquid media, fluorosilicone gel, diagnostics on |

Future

XX

Supply Voltage⁴

| | |
|----------|---------|
| 3 | 3.3 Vdc |
| 5 | 5.0 Vdc |

Transfer Function

| | |
|----------|--|
| A | 10% to 90% of V _{supply} (analog), 2 ²⁴ counts (digital) |
| B | 30% to 70% of 2 ²⁴ counts (digital) |

Output Type

| | | | |
|----------|--------------------------------|----------|--------------------------------|
| A | Analog | 3 | I ² C, Address 0x38 |
| S | SPI | 4 | I ² C, Address 0x48 |
| 0 | I ² C, Address 0x08 | 5 | I ² C, Address 0x58 |
| 1 | I ² C, Address 0x18 | 6 | I ² C, Address 0x68 |
| 2 | I ² C, Address 0x28 | 7 | I ² C, Address 0x78 |

Pressure Range

| 6 mbar to 12 bar Absolute | 600 Pa to 1.2 MPa Absolute | 2 inH ₂ O to 175 psi Absolute |
|---------------------------|----------------------------|--|
| 001BA 1 bar | 100KA 100 kPa | 015PA 15 psi |
| 1.6BA 1.6 bar | 160KA 160 kPa | 030PA 30 psi |
| 2.5BA 2.5 bar | 250KA 250 kPa | 060PA 60 psi |
| 004BA 4 bar | 400KA 400 kPa | 100PA 100 psi |
| 006BA 6 bar | 600KA 600 kPa | 150PA 150 psi |
| 010BA 10 bar | 001GA 1.2 MPa | 175PA 175 psi |
| 012BA 12 bar | | |

| Differential | Differential | Differential |
|------------------------|-----------------------|-------------------------------------|
| 006MD ±6 mbar | 600LD ±600 Pa | 002ND ±2 inH ₂ O |
| 010MD ±10 mbar | 001KD ±1 kPa | 004ND ±4 inH ₂ O |
| 016MD ±16 mbar | 1.6KD ±1.6 kPa | 005ND ±5 inH ₂ O |
| 025MD ±25 mbar | 2.5KD ±2.5 kPa | 010ND ±10 inH ₂ O |
| 040MD ±40 mbar | 004KD ±4 kPa | 020ND ±20 inH ₂ O |
| 060MD ±60 mbar | 006KD ±6 kPa | 030ND ±30 inH ₂ O |
| 100MD ±100 mbar | 010KD ±10 kPa | 001PD ±1 psi |
| 160MD ±160 mbar | 016KD ±16 kPa | 005PD ±5 psi |
| 250MD ±250 mbar | 025KD ±25 kPa | 015PD ±15 psi |
| 400MD ±400 mbar | 040KD ±40 kPa | 030PD ±30 psi |
| 600MD ±600 mbar | 060KD ±60 kPa | 060PD ±60 psi |
| 001BD ±1 bar | 100KD ±100 kPa | |
| 1.6BD ±1.6 bar | 160KD ±160 kPa | |
| 2.5BD ±2.5 bar | 250KD ±250 kPa | |
| 004BD ±4 bar | 400KD ±400 kPa | |

| Gage ⁵ | Gage ⁵ | Gage ⁵ |
|-----------------------|----------------------|------------------------------------|
| 010MG 10 mbar | 001KG 1 kPa | 004NG 4 inH ₂ O |
| 016MG 16 mbar | 1.6KG 1.6 kPa | 005NG 5 inH ₂ O |
| 025MG 25 mbar | 2.5KG 2.5 kPa | 010NG 10 inH ₂ O |
| 040MG 40 mbar | 004KG 4 kPa | 020NG 20 inH ₂ O |
| 060MG 60 mbar | 006KG 6 kPa | 030NG 30 inH ₂ O |
| 100MG 100 mbar | 010KG 10 kPa | 001PG 1 psi |
| 160MG 160 mbar | 016KG 16 kPa | 005PG 5 psi |
| 250MG 250 mbar | 025KG 25 kPa | 015PG 15 psi |
| 400MG 400 mbar | 040KG 40 kPa | 030PG 30 psi |
| 600MG 600 mbar | 060KG 60 kPa | 060PG 60 psi |
| 001BG 1 bar | 100KG 100 kPa | 100PG 100 psi |
| 1.6BG 1.6 bar | 160KG 160 kPa | 150PG 150 psi |
| 2.5BG 2.5 bar | 250KG 250 kPa | 175PG 175 psi |
| 004BG 4 bar | 400KG 400 kPa | |
| 006BG 6 bar | 600KG 600 kPa | |
| 008BG 8 bar | 800KG 800 kPa | |
| 010BG 10 bar | 001GG 1 MPa | |
| 012BG 12 bar | 1.2GG 1.2 MPa | |

¹ The "DA" Pressure Port is only available with Product Options "N" and "D". The "DA" Pressure Port is available in standard listings with pressure ranges up to 400 mbar | ±160 mbar. For higher pressure ranges, please consult the factory.

² Product Options "N" and "D" are only available with gage pressure ranges 10 mbar to 40 mbar | 1 kPa to 4 kPa | 4 inH₂O to 20 inH₂O and differential pressure ranges ±6 mbar to ±25 mbar | ±1 kPa to ±2.5 kPa | ±2 inH₂O to ±10 inH₂O.

³ Product Options "G" and "F" are only available with pressure ranges 600 mbar | 15 psi gage and ±250 mbar | ±5 psi differential and above. See Tables 14, 16, and 18 for pressure range specifications when using fluorosilicone gel.

⁴ 5 Vdc supply voltage and diagnostic options are only available with analog output listings. They are not available with digital output listings.

⁵ 10 mbar, 1 kPa, and 4 inH₂O pressure ranges are limited to 11 bit resolution for analog output listings.

ABP2 SERIES BASIC BOARD MOUNT PRESSURE SENSORS

SELECT ABP2 SERIES SENSORS MOUNTED ON BREAKOUT BOARDS

Breakout boards, with or without the sensor premounted (see Figure 8 and Tables 10, 11, and 12) are designed for use with the Honeywell SEB Sensor Evaluation Kit.

FIGURE 8. ABP2 SERIES SENSORS AND BREAKOUT BOARDS

SN Leadless SMT sensor premounted on breakout board (ABP2LSNT060PGSA3BB)

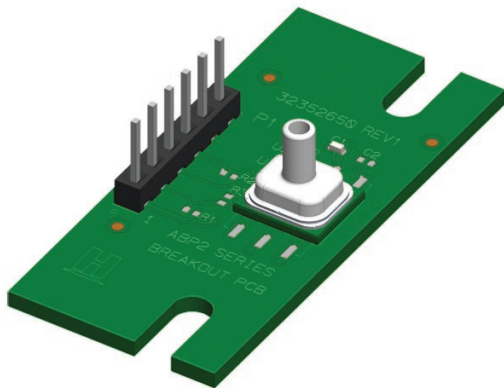

Breakout board (ABP2-BREAKOUT-BRD)

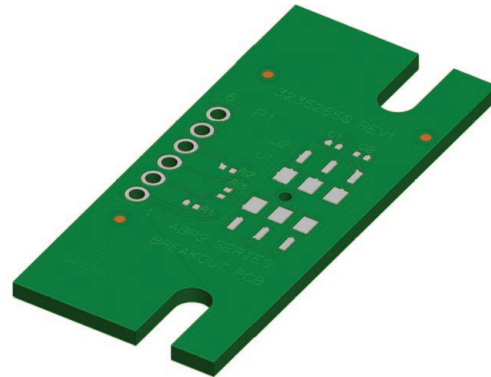

TABLE 10. ORDER GUIDE FOR ABP2 SERIES SENSORS AND BREAKOUT BOARDS

| CATALOG LISTING | DESCRIPTION |
|--------------------|--|
| ABP2MRRN004ND2B3BB | ABP2 Series sensor with SMT package, plastic dual radial barbed ports, same side pressure port, dry gases only, no diagnostics, ± 4 inH ₂ O differential pressure range, I ² C address 0x28, 30% to 70% of 2 ²⁴ counts digital transfer function, 3.3 Vdc supply premounted on breakout board |
| ABP2MDAN004ND2B3BB | ABP2 Series sensor with SMT package, plastic dual axial barbed ports same side, dry gases only, no diagnostics, ± 4 inH ₂ O differential pressure range, I ² C address 0x28, 30% to 70% of 2 ²⁴ counts digital transfer function, 3.3 Vdc supply premounted on breakout board |
| ABP2MVNT400MG2A3BB | ABP2 Series sensor with leaded SMT package, metal single axial tapered pressure port, liquid media, food-grade silicone gel, no diagnostics, 400 mbar gage pressure range, I ² C address 0x28, 10% to 90% of 2 ²⁴ counts digital transfer function, 3.3 Vdc supply premounted on breakout board |
| ABP2LANT001PG2A3BB | ABP2 Series sensor with leadless SMT package, plastic single axial barbed pressure port, liquid media, food-grade silicone gel, no diagnostics, 1 psi gage pressure range, I ² C address 0x28, 10% to 90% of 2 ²⁴ counts digital transfer function, 3.3 Vdc supply premounted on breakout board |
| ABP2LSNT060PGSA3BB | ABP2 Series sensor with leadless SMT package, metal single axial straight barbless pressure port, liquid media, food-grade silicone gel, no diagnostics, 60 psi gage pressure range, SPI output type, 10% to 90% of 2 ²⁴ counts digital transfer function, 3.3 Vdc supply premounted on breakout board |
| ABP2LANT001BA2A3BB | ABP2 Series sensor with leadless SMT package, plastic single axial barbed pressure port, liquid media, food-grade silicone gel, no diagnostics, 1 bar absolute pressure range, I ² C address 0x28, 10% to 90% of 2 ²⁴ counts digital transfer function, 3.3 Vdc supply premounted on breakout board |
| ABP2-BREAKOUT-BRD | Bare breakout board for use with SMT and leadless SMT packages with AN, SN, VN, NN, RN, or RR pressure ports |

ABP2 SERIES BASIC BOARD MOUNT PRESSURE SENSORS

SELECT ABP2 SERIES SENSORS MOUNTED ON BREAKOUT BOARDS (CONTINUED)

| TABLE 11. BREAKOUT BOARD ASSEMBLY DETAILS | | | | | |
|---|----------------|--|--------------------------|-----------|---|
| SL NUMBER | REF DESIGNATOR | DESCRIPTION | MANUFACTURER PART NUMBER | POPULATE | DESCRIPTION |
| 1 | C1 | capacitor, ceramic, 0.1 μ F, 16 V, X7R, 10% SMD 0402 | GCM155R71C104KA55J | populated | a decoupling capacitor, breakout board shipped with this part assembled |
| 2 | C2 | capacitor, ceramic SMD 0402 | NA | DNP | do not populate |
| 3 | R1, R2 | resistor SMD 0402 SCL line/R1 and SDA line R2 | NA | DNP | optional pull-up resistors for I ² C output (not populated on the breakout board); recommended pull-up resistor value: 1 kOhm to 10 kOhm |
| 4 | R3 | resistor, SMD 0402 | NA | DNP | jumper resistor, do not populate |
| 5 | P1 | connector, header, 6 pin, straight, 2,54 mm pitch through hole | 826629-6 | populated | 6 pin connector |
| 6 | U1 | ABP2 sensor | ABP2 | populated | respective ABP2 sensor mounted |

| TABLE 12. BREAKOUT BOARD PINOUTS | | |
|----------------------------------|-------------------------|-----------------|
| PIN NUMBER | I ² C OUTPUT | SPI OUTPUT |
| 1 | V _{DD} | V _{DD} |
| 2 | SCL | SCLK |
| 3 | EOC | MISO |
| 4 | SDA | MOSI |
| 5 | GND | GND |
| 6 | NC | SS |

ABP2 SERIES BASIC BOARD MOUNT PRESSURE SENSORS

TABLE 13. PRESSURE RANGE SPECIFICATIONS: 6 MBAR TO 12 BAR FOR PRODUCT OPTIONS "N", "D", "T" AND "V" ONLY

| PRESSURE RANGE | PRESSURE RANGE | | UNIT | OVERPRESSURE ¹ | | BURST PRESSURE ² | | COMMON MODE PRESSURE ³ | TOTAL ERROR BAND ⁴ (%FSS) | | | TYPICAL OFFSET SHIFT WITH REFLOW (%FSS) | LONG-TERM STABILITY (1000 HR) (%FSS) | TRANSFER FUNCTION FOR DIGITAL VERSIONS |
|---------------------|-------------------|-------------------|------|---------------------------|-------------|-----------------------------|-------------|-----------------------------------|--------------------------------------|---------------|----------------|---|--------------------------------------|--|
| | P _{MIN.} | P _{MAX.} | | PORT 1 (P1) | PORT 2 (P2) | PORT 1 (P1) | PORT 2 (P2) | | 0°C TO 50°C | -20°C TO 85°C | -40°C TO 110°C | | | |
| Absolute | | | | | | | | | | | | | | |
| 001BA | 0 | 1 | bar | 16 | – | 25 | – | – | ±1.5 | ±3.0 | ±4.5 | ±1.0 | ±0.2 | A |
| 1.6BA | 0 | 1.6 | bar | 16 | – | 25 | – | – | ±1.5 | ±3.0 | ±4.5 | ±1.0 | ±0.2 | A |
| 2.5BA | 0 | 2.5 | bar | 16 | – | 25 | – | – | ±1.5 | ±3.0 | ±4.5 | ±1.0 | ±0.2 | A |
| Differential | | | | | | | | | | | | | | |
| 006MD | -6 | 6 | mbar | 700 | 700 | 7000 | 1000 | – | ±2.0 | ±3.5 | – | ±1.0 | ±0.3 | B |
| 010MD | -10 | 10 | mbar | 700 | 700 | 7000 | 1000 | – | ±2.0 | ±3.5 | – | ±1.0 | ±0.3 | B |
| 016MD | -16 | 16 | mbar | 700 | 700 | 7000 | 1000 | – | ±2.0 | ±3.5 | – | ±1.0 | ±0.3 | A |
| 025MD | -25 | 25 | mbar | 700 | 700 | 7000 | 1000 | – | ±2.0 | ±3.5 | – | ±1.0 | ±0.3 | A |
| 040MD | -40 | 40 | mbar | 2000 | 1000 | 7000 | 2000 | 2000 | ±1.5 | ±3.0 | ±4.5 | ±1.0 | ±0.2 | A |
| 060MD | -60 | 60 | mbar | 2000 | 1000 | 7000 | 2000 | 2000 | ±1.5 | ±3.0 | ±4.5 | ±1.0 | ±0.2 | A |
| 100MD | -100 | 100 | mbar | 2000 | 1000 | 7000 | 2000 | 2000 | ±1.5 | ±3.0 | ±4.5 | ±1.0 | ±0.2 | A |
| 160MD | -160 | 160 | mbar | 2000 | 1000 | 7000 | 2000 | 2000 | ±1.5 | ±3.0 | ±4.5 | ±1.0 | ±0.2 | A |
| 250MD | -250 | 250 | mbar | 16000 | – | 25000 | – | 10000 | ±1.5 | ±3.0 | ±4.5 | ±1.0 | ±0.6 | A |
| 400MD | -400 | 400 | mbar | 16000 | – | 25000 | – | 10000 | ±1.5 | ±3.0 | ±4.5 | ±1.0 | ±0.6 | A |
| 600MD | -600 | 600 | mbar | 16000 | – | 25000 | – | 10000 | ±1.5 | ±3.0 | ±4.5 | ±1.0 | ±0.6 | A |
| 001BD | -1 | 1 | bar | 16 | – | 25 | – | 16 | ±1.5 | ±3.0 | ±4.5 | ±1.0 | ±0.2 | A |
| 1.6BD | -1.6 | 1.6 | bar | 16 | – | 25 | – | 16 | ±1.5 | ±3.0 | ±4.5 | ±1.0 | ±0.2 | A |
| 2.5BD | -2.5 | 2.5 | bar | 16 | – | 25 | – | 16 | ±1.5 | ±3.0 | ±4.5 | ±1.0 | ±0.2 | A |
| 004BD | -4 | 4 | bar | 16 | – | 25 | – | 16 | ±1.5 | ±3.0 | ±4.5 | ±1.0 | ±0.2 | A |
| Gage | | | | | | | | | | | | | | |
| 010MG | 0 | 10 | mbar | 700 | – | 7000 | – | – | ±2.0 | ±3.5 | – | ±1.0 | ±0.3 | B |
| 016MG | 0 | 16 | mbar | 700 | – | 7000 | – | – | ±2.0 | ±3.5 | – | ±1.0 | ±0.3 | B |
| 025MG | 0 | 25 | mbar | 700 | – | 7000 | – | – | ±2.0 | ±3.5 | – | ±1.0 | ±0.3 | A |
| 040MG | 0 | 40 | mbar | 700 | – | 7000 | – | – | ±2.0 | ±3.5 | – | ±1.0 | ±0.3 | A |
| 060MG | 0 | 60 | mbar | 2000 | – | 7000 | – | – | ±1.5 | ±3.0 | ±4.5 | ±1.0 | ±0.2 | A |
| 100MG | 0 | 100 | mbar | 2000 | – | 7000 | – | – | ±1.5 | ±3.0 | ±4.5 | ±1.0 | ±0.2 | A |
| 160MG | 0 | 160 | mbar | 2000 | – | 7000 | – | – | ±1.5 | ±3.0 | ±4.5 | ±1.0 | ±0.2 | A |
| 250MG | 0 | 250 | mbar | 2000 | – | 7000 | – | – | ±1.5 | ±3.0 | ±4.5 | ±1.0 | ±0.2 | A |
| 400MG | 0 | 400 | mbar | 2000 | – | 7000 | – | – | ±1.5 | ±3.0 | ±4.5 | ±1.0 | ±0.2 | A |
| 600MG | 0 | 600 | mbar | 16000 | – | 25000 | – | – | ±1.5 | ±3.0 | ±4.5 | ±1.0 | ±0.6 | A |
| 001BG | 0 | 1 | bar | 16 | – | 25 | – | – | ±1.5 | ±3.0 | ±4.5 | ±1.0 | ±0.5 | A |
| 1.6BG | 0 | 1.6 | bar | 16 | – | 25 | – | – | ±1.5 | ±3.0 | ±4.5 | ±1.0 | ±0.2 | A |
| 2.5BG | 0 | 2.5 | bar | 16 | – | 25 | – | – | ±1.5 | ±3.0 | ±4.5 | ±1.0 | ±0.2 | A |
| 004BG | 0 | 4 | bar | 16 | – | 25 | – | – | ±1.5 | ±3.0 | ±4.5 | ±1.0 | ±0.2 | A |
| 006BG | 0 | 6 | bar | 16 | – | 25 | – | – | ±1.5 | ±3.0 | ±4.5 | ±1.0 | ±0.2 | A |
| 008BG | 0 | 8 | bar | 16 | – | 25 | – | – | ±1.5 | ±3.0 | ±4.5 | ±1.0 | ±0.2 | A |
| 010BG | 0 | 10 | bar | 16 | – | 25 | – | – | ±1.5 | ±3.0 | ±4.5 | ±1.0 | ±0.2 | A |
| 012BG | 0 | 12 | bar | 16 | – | 25 | – | – | ±1.5 | ±3.0 | ±4.5 | ±1.0 | ±0.2 | A |

¹ **Overpressure:** The maximum pressure which may safely be applied to the product for it to remain in specification once pressure is returned to the operating pressure range. Exposure to higher pressures may cause permanent damage to the product. Unless otherwise specified, this applies to all available pressure ports at any temperature within the operating temperature range.

² **Burst Pressure:** The maximum pressure that may be applied to any port of the product without causing escape of pressure media. The product should not be expected to function after exposure to any pressure beyond the burst pressure.

³ **Common Mode Pressure:** The maximum pressure that can be applied simultaneously to both ports of a differential pressure sensor without causing changes in specified performance.

⁴ **Total Error Band:** The maximum deviation from the ideal transfer function over the entire compensated temperature and pressure range without causing changes in specified performance.

ABP2 SERIES BASIC BOARD MOUNT PRESSURE SENSORS

TABLE 14. PRESSURE RANGE SPECIFICATIONS: 250 MBAR TO 12 BAR FOR PRODUCT OPTIONS "G" AND "F" ONLY

| PRESSURE RANGE | PRESSURE RANGE | | UNIT | OVERPRESSURE ¹ | | BURST PRESSURE ² | | COMMON MODE PRESSURE ³ | TOTAL ERROR BAND ⁴ (%FSS) | | | TYPICAL OFFSET SHIFT WITH REFLOW (%FSS) | LONG-TERM STABILITY (1000 HR) (%FSS) | TRANSFER FUNCTION FOR DIGITAL VERSIONS |
|---------------------|-------------------|-------------------|------|---------------------------|-------------|-----------------------------|-------------|-----------------------------------|--------------------------------------|---------------|----------------|---|--------------------------------------|--|
| | P _{MIN.} | P _{MAX.} | | PORT 1 (P1) | PORT 2 (P2) | PORT 1 (P1) | PORT 2 (P2) | | 0°C TO 50°C | -20°C TO 85°C | -40°C TO 110°C | | | |
| Absolute | | | | | | | | | | | | | | |
| 001BA | 0 | 1 | bar | 16 | — | 25 | — | — | ±2.0 | ±3.0 | ±4.5 | ±1.0 | ±0.5 | A |
| 1.6BA | 0 | 1.6 | bar | 16 | — | 25 | — | — | ±2.0 | ±3.0 | ±4.5 | ±1.0 | ±0.5 | A |
| 2.5BA | 0 | 2.5 | bar | 16 | — | 25 | — | — | ±2.0 | ±3.0 | ±4.5 | ±1.0 | ±0.5 | A |
| 004BA | 0 | 4 | bar | 16 | — | 25 | — | — | ±2.0 | ±3.0 | ±4.5 | ±1.0 | ±0.5 | A |
| 006BA | 0 | 6 | bar | 16 | — | 25 | — | — | ±2.0 | ±3.0 | ±4.5 | ±1.0 | ±0.5 | A |
| 008BA | 0 | 8 | bar | 16 | — | 25 | — | — | ±2.0 | ±3.0 | ±4.5 | ±1.0 | ±0.5 | A |
| 010BA | 0 | 10 | bar | 16 | — | 25 | — | — | ±2.0 | ±3.0 | ±4.5 | ±1.0 | ±0.5 | A |
| 012BA | 0 | 12 | bar | 16 | — | 25 | — | — | ±2.0 | ±3.0 | ±4.5 | ±1.0 | ±0.5 | A |
| Differential | | | | | | | | | | | | | | |
| 250MD | -250 | 250 | mbar | 16000 | — | 25000 | — | 16000 | ±2.0 | ±3.0 | ±4.5 | ±1.0 | ±0.5 | A |
| 400MD | -400 | 400 | mbar | 16000 | — | 25000 | — | 16000 | ±2.0 | ±3.0 | ±4.5 | ±1.0 | ±0.5 | A |
| 600MD | -600 | 600 | mbar | 16000 | — | 25000 | — | 16000 | ±2.0 | ±3.0 | ±4.5 | ±1.0 | ±0.5 | A |
| 001BD | -1 | 1 | bar | 16 | — | 25 | — | 16 | ±2.0 | ±3.0 | ±4.5 | ±1.0 | ±0.5 | A |
| 1.6BD | -1.6 | 1.6 | bar | 16 | — | 25 | — | 16 | ±2.0 | ±3.0 | ±4.5 | ±1.0 | ±0.5 | A |
| 2.5BD | -2.5 | 2.5 | bar | 16 | — | 25 | — | 16 | ±2.0 | ±3.0 | ±4.5 | ±1.0 | ±0.5 | A |
| 004BD | -4 | 4 | bar | 16 | — | 25 | — | 16 | ±2.0 | ±3.0 | ±4.5 | ±1.0 | ±0.5 | A |
| Gage | | | | | | | | | | | | | | |
| 600MG | 0 | 600 | mbar | 16000 | — | 25000 | — | — | ±2.0 | ±3.0 | ±4.5 | ±1.0 | ±0.5 | A |
| 001BG | 0 | 1 | bar | 16 | — | 25 | — | — | ±2.0 | ±3.0 | ±4.5 | ±1.0 | ±0.5 | A |
| 1.5BG | 0 | 1.6 | bar | 16 | — | 25 | — | — | ±2.0 | ±3.0 | ±4.5 | ±1.0 | ±0.5 | A |
| 2.5BG | 0 | 2.5 | bar | 16 | — | 25 | — | — | ±2.0 | ±3.0 | ±4.5 | ±1.0 | ±0.5 | A |
| 004BG | 0 | 4 | bar | 16 | — | 25 | — | — | ±2.0 | ±3.0 | ±4.5 | ±1.0 | ±0.5 | A |
| 006BG | 0 | 6 | bar | 16 | — | 25 | — | — | ±2.0 | ±3.0 | ±4.5 | ±1.0 | ±0.5 | A |
| 008BG | 0 | 8 | bar | 16 | — | 25 | — | — | ±2.0 | ±3.0 | ±4.5 | ±1.0 | ±0.5 | A |
| 010BG | 0 | 10 | bar | 16 | — | 25 | — | — | ±2.0 | ±3.0 | ±4.5 | ±1.0 | ±0.5 | A |
| 012BG | 0 | 12 | bar | 16 | — | 25 | — | — | ±2.0 | ±3.0 | ±4.5 | ±1.0 | ±0.5 | A |

¹ **Overpressure:** The maximum pressure which may safely be applied to the product for it to remain in specification once pressure is returned to the operating pressure range. Exposure to higher pressures may cause permanent damage to the product. Unless otherwise specified, this applies to all available pressure ports at any temperature within the operating temperature range.

² **Burst Pressure:** The maximum pressure that may be applied to any port of the product without causing escape of pressure media. The product should not be expected to function after exposure to any pressure beyond the burst pressure.

³ **Common Mode Pressure:** The maximum pressure that can be applied simultaneously to both ports of a differential pressure sensor without causing changes in specified performance.

⁴ **Total Error Band:** The maximum deviation from the ideal transfer function over the entire compensated temperature and pressure range without causing changes in specified performance.

ABP2 SERIES BASIC BOARD MOUNT PRESSURE SENSORS

TABLE 15. PRESSURE RANGE SPECIFICATIONS: 600 PA TO 1.2 MPA FOR PRODUCT OPTIONS "N", "D", "T" AND "V" ONLY

| PRESSURE RANGE | PRESSURE RANGE | | UNIT | OVERPRESSURE ¹ | | BURST PRESSURE ² | | COMMON MODE PRESSURE ³ | TOTAL ERROR BAND ⁴ (%FSS) | | | TYPICAL OFFSET SHIFT WITH REFLOW (%FSS) | LONG-TERM STABILITY (1000 HR) (%FSS) | TRANSFER FUNCTION FOR DIGITAL VERSIONS |
|---------------------|-------------------|-------------------|------|---------------------------|-------------|-----------------------------|-------------|-----------------------------------|--------------------------------------|---------------|----------------|---|--------------------------------------|--|
| | P _{MIN.} | P _{MAX.} | | PORT 1 (P1) | PORT 2 (P2) | PORT 1 (P1) | PORT 2 (P2) | | 0°C TO 50°C | -20°C TO 85°C | -40°C TO 110°C | | | |
| Absolute | | | | | | | | | | | | | | |
| 100KA | 0 | 100 | kPa | 1600 | — | 2500 | — | — | ±1.5 | ±3.0 | ±4.5 | ±1.0 | ±0.2 | A |
| 160KA | 0 | 160 | kPa | 1600 | — | 2500 | — | — | ±1.5 | ±3.0 | ±4.5 | ±1.0 | ±0.2 | A |
| 250KA | 0 | 250 | kPa | 1600 | — | 2500 | — | — | ±1.5 | ±3.0 | ±4.5 | ±1.0 | ±0.2 | A |
| Differential | | | | | | | | | | | | | | |
| 600LD | -600 | 600 | Pa | 70000 | 70000 | 70000 | 100000 | — | ±2.0 | ±3.5 | — | ±1.0 | ±0.3 | B |
| 001KD | -1 | 1 | kPa | 70 | 70 | 700 | 100 | — | ±2.0 | ±3.5 | — | ±1.0 | ±0.3 | B |
| 1.6KD | -1.6 | 1.6 | kPa | 70 | 70 | 700 | 100 | — | ±2.0 | ±3.5 | — | ±1.0 | ±0.3 | A |
| 2.5KD | -2.5 | 2.5 | kPa | 70 | 70 | 700 | 100 | — | ±2.0 | ±3.5 | — | ±1.0 | ±0.3 | A |
| 004KD | -4 | 4 | kPa | 200 | 100 | 700 | 200 | 200 | ±1.5 | ±3.0 | ±4.5 | ±1.0 | ±0.2 | A |
| 006KD | -6 | 6 | kPa | 200 | 100 | 700 | 200 | 200 | ±1.5 | ±3.0 | ±4.5 | ±1.0 | ±0.2 | A |
| 010KD | -10 | 10 | kPa | 200 | 100 | 700 | 200 | 200 | ±1.5 | ±3.0 | ±4.5 | ±1.0 | ±0.2 | A |
| 016KD | -16 | 16 | kPa | 200 | 100 | 700 | 200 | 200 | ±1.5 | ±3.0 | ±4.5 | ±1.0 | ±0.2 | A |
| 025KD | -25 | 25 | kPa | 1600 | — | 2500 | — | 16000 | ±1.5 | ±3.0 | ±4.5 | ±1.0 | ±0.6 | A |
| 040KD | -40 | 40 | kPa | 1600 | — | 2500 | — | 16000 | ±1.5 | ±3.0 | ±4.5 | ±1.0 | ±0.6 | A |
| 060KD | -60 | 60 | kPa | 1600 | — | 2500 | — | 16000 | ±1.5 | ±3.0 | ±4.5 | ±1.0 | ±0.6 | A |
| 100KD | -100 | 100 | kPa | 1600 | — | 2500 | — | 16000 | ±1.5 | ±3.0 | ±4.5 | ±1.0 | ±0.2 | A |
| 160KD | -160 | 160 | kPa | 1600 | — | 2500 | — | 16000 | ±1.5 | ±3.0 | ±4.5 | ±1.0 | ±0.2 | A |
| 250KD | -250 | 250 | kPa | 1600 | — | 2500 | — | 16000 | ±1.5 | ±3.0 | ±4.5 | ±1.0 | ±0.2 | A |
| 400KD | -400 | 400 | kPa | 1600 | — | 2500 | — | 16000 | ±1.5 | ±3.0 | ±4.5 | ±1.0 | ±0.2 | A |
| Gage | | | | | | | | | | | | | | |
| 001KG | 0 | 1 | kPa | 70 | — | 700 | — | — | ±2.0 | ±3.5 | — | ±1.0 | ±0.3 | B |
| 1.6KG | 0 | 1.6 | kPa | 70 | — | 700 | — | — | ±2.0 | ±3.5 | — | ±1.0 | ±0.3 | B |
| 2.5KG | 0 | 2.5 | kPa | 70 | — | 700 | — | — | ±2.0 | ±3.5 | — | ±1.0 | ±0.3 | A |
| 004KG | 0 | 4 | kPa | 70 | — | 700 | — | — | ±2.0 | ±3.5 | — | ±1.0 | ±0.3 | A |
| 006KG | 0 | 6 | kPa | 200 | — | 700 | — | — | ±1.5 | ±3.0 | ±4.5 | ±1.0 | ±0.2 | A |
| 010KG | 0 | 10 | kPa | 200 | — | 700 | — | — | ±1.5 | ±3.0 | ±4.5 | ±1.0 | ±0.2 | A |
| 016KG | 0 | 16 | kPa | 200 | — | 700 | — | — | ±1.5 | ±3.0 | ±4.5 | ±1.0 | ±0.2 | A |
| 025KG | 0 | 25 | kPa | 200 | — | 700 | — | — | ±1.5 | ±3.0 | ±4.5 | ±1.0 | ±0.2 | A |
| 040KG | 0 | 40 | kPa | 200 | — | 700 | — | — | ±1.5 | ±3.0 | ±4.5 | ±1.0 | ±0.2 | A |
| 060KG | 0 | 60 | kPa | 1600 | — | 2500 | — | — | ±1.5 | ±3.0 | ±4.5 | ±1.0 | ±0.6 | A |
| 100KG | 0 | 100 | kPa | 1600 | — | 2500 | — | — | ±1.5 | ±3.0 | ±4.5 | ±1.0 | ±0.5 | A |
| 160KG | 0 | 160 | kPa | 1600 | — | 2500 | — | — | ±1.5 | ±3.0 | ±4.5 | ±1.0 | ±0.2 | A |
| 250KG | 0 | 250 | kPa | 1600 | — | 2500 | — | — | ±1.5 | ±3.0 | ±4.5 | ±1.0 | ±0.2 | A |
| 400KG | 0 | 400 | kPa | 1600 | — | 2500 | — | — | ±1.5 | ±3.0 | ±4.5 | ±1.0 | ±0.2 | A |
| 600KG | 0 | 600 | kPa | 1600 | — | 2500 | — | — | ±1.5 | ±3.0 | ±4.5 | ±1.0 | ±0.2 | A |
| 800KG | 0 | 800 | kPa | 1600 | — | 2500 | — | — | ±1.5 | ±3.0 | ±4.5 | ±1.0 | ±0.2 | A |
| 001GG | 0 | 1 | MPa | 1.6 | — | 2.5 | — | — | ±1.5 | ±3.0 | ±4.5 | ±1.0 | ±0.2 | A |
| 1.2GG | 0 | 1.2 | MPa | 1.6 | — | 2.5 | — | — | ±1.5 | ±3.0 | ±4.5 | ±1.0 | ±0.2 | A |

¹ **Overpressure:** The maximum pressure which may safely be applied to the product for it to remain in specification once pressure is returned to the operating pressure range. Exposure to higher pressures may cause permanent damage to the product. Unless otherwise specified, this applies to all available pressure ports at any temperature within the operating temperature range.

² **Burst Pressure:** The maximum pressure that may be applied to any port of the product without causing escape of pressure media. The product should not be expected to function after exposure to any pressure beyond the burst pressure.

³ **Common Mode Pressure:** The maximum pressure that can be applied simultaneously to both ports of a differential pressure sensor without causing changes in specified performance.

⁴ **Total Error Band:** The maximum deviation from the ideal transfer function over the entire compensated temperature and pressure range without causing changes in specified performance.

ABP2 SERIES BASIC BOARD MOUNT PRESSURE SENSORS

TABLE 16. PRESSURE RANGE SPECIFICATIONS: 25 KPA TO 1.2 MPA FOR PRODUCT OPTIONS "G" AND "F" ONLY

| PRESSURE RANGE | PRESSURE RANGE | | UNIT | OVERPRESSURE ¹ | | BURST PRESSURE ² | | COMMON MODE PRESSURE ³ | TOTAL ERROR BAND ⁴ (%FSS) | | | TYPICAL OFFSET SHIFT WITH REFLOW (%FSS) | LONG-TERM STABILITY (1000 HR) (%FSS) | TRANSFER FUNCTION FOR DIGITAL VERSIONS |
|---------------------|-------------------|-------------------|------|---------------------------|-------------|-----------------------------|-------------|-----------------------------------|--------------------------------------|---------------|----------------|---|--------------------------------------|--|
| | P _{MIN.} | P _{MAX.} | | PORT 1 (P1) | PORT 2 (P2) | PORT 1 (P1) | PORT 2 (P2) | | 0°C TO 50°C | -20°C TO 85°C | -40°C TO 110°C | | | |
| Absolute | | | | | | | | | | | | | | |
| 100KA | 0 | 100 | kPa | 1600 | — | 2500 | — | — | ±2.0 | ±3.0 | ±4.5 | ±1.0 | ±0.5 | A |
| 160KA | 0 | 160 | kPa | 1600 | — | 2500 | — | — | ±2.0 | ±3.0 | ±4.5 | ±1.0 | ±0.5 | A |
| 250KA | 0 | 250 | kPa | 1600 | — | 2500 | — | — | ±2.0 | ±3.0 | ±4.5 | ±1.0 | ±0.5 | A |
| 400KG | 0 | 400 | kPa | 1600 | — | 2500 | — | — | ±2.0 | ±3.0 | ±4.5 | ±1.0 | ±0.5 | A |
| 600KG | 0 | 600 | kPa | 1600 | — | 2500 | — | — | ±2.0 | ±3.0 | ±4.5 | ±1.0 | ±0.5 | A |
| 800KG | 0 | 800 | kPa | 1600 | — | 2500 | — | — | ±2.0 | ±3.0 | ±4.5 | ±1.0 | ±0.5 | A |
| 001GG | 0 | 1 | MPa | 1.6 | — | 2.5 | — | — | ±2.0 | ±3.0 | ±4.5 | ±1.0 | ±0.5 | A |
| 1.2GG | 0 | 1.2 | MPa | 1.6 | — | 2.5 | — | — | ±2.0 | ±3.0 | ±4.5 | ±1.0 | ±0.5 | A |
| Differential | | | | | | | | | | | | | | |
| 025KD | -25 | 25 | kPa | 1600 | — | 2500 | — | 1600 | ±2.0 | ±3.0 | ±4.5 | ±1.0 | ±0.5 | A |
| 040KD | -40 | 40 | kPa | 1600 | — | 2500 | — | 1600 | ±2.0 | ±3.0 | ±4.5 | ±1.0 | ±0.5 | A |
| 060KD | -60 | 60 | kPa | 1600 | — | 2500 | — | 1600 | ±2.0 | ±3.0 | ±4.5 | ±1.0 | ±0.5 | A |
| 100KD | -100 | 100 | kPa | 1600 | — | 2500 | — | 1600 | ±2.0 | ±3.0 | ±4.5 | ±1.0 | ±0.5 | A |
| 160KD | -160 | 160 | kPa | 1600 | — | 2500 | — | 1600 | ±2.0 | ±3.0 | ±4.5 | ±1.0 | ±0.5 | A |
| 250KD | -250 | 250 | kPa | 1600 | — | 2500 | — | 1600 | ±2.0 | ±3.0 | ±4.5 | ±1.0 | ±0.5 | A |
| 400KD | -400 | 400 | kPa | 1600 | — | 2500 | — | 1600 | ±2.0 | ±3.0 | ±4.5 | ±1.0 | ±0.5 | A |
| Gage | | | | | | | | | | | | | | |
| 060KG | 0 | 60 | kPa | 1600 | — | 2500 | — | — | ±2.0 | ±3.0 | ±4.5 | ±1.0 | ±0.5 | A |
| 100KG | 0 | 100 | kPa | 1600 | — | 2500 | — | — | ±2.0 | ±3.0 | ±4.5 | ±1.0 | ±0.5 | A |
| 160KG | 0 | 160 | kPa | 1600 | — | 2500 | — | — | ±2.0 | ±3.0 | ±4.5 | ±1.0 | ±0.5 | A |
| 250KG | 0 | 250 | kPa | 1600 | — | 2500 | — | — | ±2.0 | ±3.0 | ±4.5 | ±1.0 | ±0.5 | A |
| 400KG | 0 | 400 | kPa | 1600 | — | 2500 | — | — | ±2.0 | ±3.0 | ±4.5 | ±1.0 | ±0.5 | A |
| 600KG | 0 | 600 | kPa | 1600 | — | 2500 | — | — | ±2.0 | ±3.0 | ±4.5 | ±1.0 | ±0.5 | A |
| 800KG | 0 | 800 | kPa | 1600 | — | 2500 | — | — | ±2.0 | ±3.0 | ±4.5 | ±1.0 | ±0.5 | A |
| 001GG | 0 | 1 | MPa | 1.6 | — | 2.5 | — | — | ±2.0 | ±3.0 | ±4.5 | ±1.0 | ±0.5 | A |
| 1.2GG | 0 | 1.2 | MPa | 1.6 | — | 2.5 | — | — | ±2.0 | ±3.0 | ±4.5 | ±1.0 | ±0.5 | A |

¹ **Overpressure:** The maximum pressure which may safely be applied to the product for it to remain in specification once pressure is returned to the operating pressure range. Exposure to higher pressures may cause permanent damage to the product. Unless otherwise specified, this applies to all available pressure ports at any temperature within the operating temperature range.

² **Burst Pressure:** The maximum pressure that may be applied to any port of the product without causing escape of pressure media. The product should not be expected to function after exposure to any pressure beyond the burst pressure.

³ **Common Mode Pressure:** The maximum pressure that can be applied simultaneously to both ports of a differential pressure sensor without causing changes in specified performance.

⁴ **Total Error Band:** The maximum deviation from the ideal transfer function over the entire compensated temperature and pressure range without causing changes in specified performance.

ABP2 SERIES BASIC BOARD MOUNT PRESSURE SENSORS

TABLE 17. PRESSURE RANGE SPECIFICATIONS: 2 INH₂O TO 175 PSI FOR PRODUCT OPTIONS "N", "D", "T" AND "V" ONLY

| PRESSURE RANGE | PRESSURE RANGE | | UNIT | OVERPRESSURE ¹ | | BURST PRESSURE ² | | COMMON MODE PRESSURE ³ | TOTAL ERROR BAND ⁴ (%FSS) | | | TYPICAL OFFSET SHIFT WITH REFLOW (%FSS) | LONG-TERM STABILITY (1000 HR) (%FSS) | TRANSFER FUNCTION FOR DIGITAL VERSIONS |
|---------------------|-------------------|-------------------|--------------------|---------------------------|-------------|-----------------------------|-------------|-----------------------------------|--------------------------------------|---------------|----------------|---|--------------------------------------|--|
| | P _{MIN.} | P _{MAX.} | | PORT 1 (P1) | PORT 2 (P2) | PORT 1 (P1) | PORT 2 (P2) | | 0°C TO 50°C | -20°C TO 85°C | -40°C TO 110°C | | | |
| Absolute | | | | | | | | | | | | | | |
| 015PA | 0 | 15 | psi | 240 | — | 375 | — | — | ±1.5 | ±3.0 | ±4.5 | ±1.0 | ±0.2 | A |
| 030PA | 0 | 30 | psi | 240 | — | 375 | — | — | ±1.5 | 3.0 | ±4.5 | ±1.0 | ±0.2 | A |
| Differential | | | | | | | | | | | | | | |
| 002ND | -2 | 2 | inH ₂ O | 270 | 270 | 2800 | 415 | — | ±2.0 | ±3.5 | — | ±1.0 | ±0.3 | B |
| 004ND | -4 | 4 | inH ₂ O | 270 | 270 | 2800 | 415 | — | ±2.0 | ±3.5 | — | ±1.0 | ±0.3 | B |
| 005ND | -5 | 5 | inH ₂ O | 270 | 270 | 2800 | 415 | — | ±2.0 | ±3.5 | — | ±1.0 | ±0.3 | A |
| 010ND | -10 | 10 | inH ₂ O | 270 | 270 | 2800 | 415 | — | ±2.0 | ±3.5 | — | ±1.0 | ±0.3 | A |
| 020ND | -20 | 20 | inH ₂ O | 830 | 415 | 2800 | 830 | 830 | ±1.5 | ±3.0 | ±4.5 | ±1.0 | ±0.2 | A |
| 030ND | -30 | 30 | inH ₂ O | 830 | 415 | 2800 | 830 | 830 | ±1.5 | ±3.0 | ±4.5 | ±1.0 | ±0.2 | A |
| 001PD | -1 | 1 | psi | 30 | 15 | 100 | 830 | 30 | ±1.5 | ±3.0 | ±4.5 | ±1.0 | ±0.2 | A |
| 005PD | -5 | 5 | psi | 240 | — | 375 | — | 240 | ±1.5 | ±3.0 | ±4.5 | ±1.0 | ±0.6 | A |
| 015PD | -15 | 15 | psi | 240 | — | 375 | — | 240 | ±1.5 | ±3.0 | ±4.5 | ±1.0 | ±0.2 | A |
| 030PD | -30 | 30 | psi | 240 | — | 375 | — | 240 | ±2.0 | ±3.0 | ±4.5 | ±1.0 | ±0.2 | A |
| 060PD | -60 | 60 | psi | 240 | — | 375 | — | 240 | ±2.0 | ±3.0 | ±4.5 | ±1.0 | ±0.2 | A |
| Gage | | | | | | | | | | | | | | |
| 004NG | 0 | 4 | inH ₂ O | 270 | — | 2800 | — | — | ±2.0 | ±3.5 | — | ±1.0 | ±0.3 | B |
| 005NG | 0 | 5 | inH ₂ O | 270 | — | 2800 | — | — | ±2.0 | ±3.5 | — | ±1.0 | ±0.3 | B |
| 010NG | 0 | 10 | inH ₂ O | 270 | — | 2800 | — | — | ±2.0 | ±3.5 | — | ±1.0 | ±0.3 | A |
| 020NG | 0 | 20 | inH ₂ O | 270 | — | 2800 | — | — | ±2.0 | ±3.5 | — | ±1.0 | ±0.3 | A |
| 030NG | 0 | 30 | inH ₂ O | 830 | — | 2800 | — | — | ±1.5 | ±3.0 | ±4.5 | ±1.0 | ±0.2 | A |
| 001PG | 0 | 1 | psi | 30 | — | 100 | — | — | ±1.5 | ±3.0 | ±4.5 | ±1.0 | ±0.2 | A |
| 005PG | 0 | 5 | psi | 30 | — | 100 | — | — | ±1.5 | ±3.0 | ±4.5 | ±1.0 | ±0.2 | A |
| 015PG | 0 | 15 | psi | 240 | — | 375 | — | — | ±1.5 | ±3.0 | ±4.5 | ±1.0 | ±0.5 | A |
| 030PG | 0 | 30 | psi | 240 | — | 375 | — | — | ±1.5 | ±3.0 | ±4.5 | ±1.0 | ±0.2 | A |
| 060PG | 0 | 60 | psi | 240 | — | 375 | — | — | ±1.5 | ±3.0 | ±4.5 | ±1.0 | ±0.2 | A |
| 100PG | 0 | 100 | psi | 240 | — | 375 | — | — | ±1.5 | ±3.0 | ±4.5 | ±1.0 | ±0.2 | A |
| 150PG | 0 | 150 | psi | 240 | — | 375 | — | — | ±1.5 | ±3.0 | ±4.5 | ±1.0 | ±0.2 | A |
| 175PG | 0 | 175 | psi | 240 | — | 375 | — | — | ±1.5 | ±3.0 | ±4.5 | ±1.0 | ±0.2 | A |

¹ **Overpressure:** The maximum pressure which may safely be applied to the product for it to remain in specification once pressure is returned to the operating pressure range. Exposure to higher pressures may cause permanent damage to the product. Unless otherwise specified, this applies to all available pressure ports at any temperature within the operating temperature range.

² **Burst Pressure:** The maximum pressure that may be applied to any port of the product without causing escape of pressure media. The product should not be expected to function after exposure to any pressure beyond the burst pressure.

³ **Common Mode Pressure:** The maximum pressure that can be applied simultaneously to both ports of a differential pressure sensor without causing changes in specified performance.

⁴ **Total Error Band:** The maximum deviation from the ideal transfer function over the entire compensated temperature and pressure range without causing changes in specified performance.

ABP2 SERIES BASIC BOARD MOUNT PRESSURE SENSORS

TABLE 18. PRESSURE RANGE SPECIFICATIONS: 5 PSI TO 175 PSI FOR PRODUCT OPTIONS "G" AND "F" ONLY

| PRESSURE RANGE | PRESSURE RANGE | | UNIT | OVERPRESSURE ¹ | | BURST PRESSURE ² | | COMMON MODE PRESSURE ³ | TOTAL ERROR BAND ⁴ (%FSS) | | | TYPICAL OFFSET SHIFT WITH REFLOW (%FSS) | LONG-TERM STABILITY (1000 HR) (%FSS) | TRANSFER FUNCTION FOR DIGITAL VERSIONS |
|---------------------|-------------------|-------------------|------|---------------------------|-------------|-----------------------------|-------------|-----------------------------------|--------------------------------------|---------------|----------------|---|--------------------------------------|--|
| | P _{MIN.} | P _{MAX.} | | PORT 1 (P1) | PORT 2 (P2) | PORT 1 (P1) | PORT 2 (P2) | | 0°C TO 50°C | -20°C TO 85°C | -40°C TO 110°C | | | |
| Absolute | | | | | | | | | | | | | | |
| 015PA | 0 | 15 | psi | 240 | — | 375 | — | — | ±2.0 | ±3.0 | ±4.5 | ±1.0 | ±0.5 | A |
| 030PA | 0 | 30 | psi | 240 | — | 375 | — | — | ±2.0 | ±3.0 | ±4.5 | ±1.0 | ±0.5 | A |
| 060PA | 0 | 60 | psi | 240 | — | 375 | — | — | ±2.0 | ±3.0 | ±4.5 | ±1.0 | ±0.5 | A |
| 100PA | 0 | 100 | psi | 240 | — | 375 | — | — | ±2.0 | ±3.0 | ±4.5 | ±1.0 | ±0.5 | A |
| 150PA | 0 | 150 | psi | 240 | — | 375 | — | — | ±2.0 | ±3.0 | ±4.5 | ±1.0 | ±0.5 | A |
| 175PA | 0 | 175 | psi | 240 | — | 375 | — | — | ±2.0 | ±3.0 | ±4.5 | ±1.0 | ±0.5 | A |
| Differential | | | | | | | | | | | | | | |
| 005PD | -5 | 5 | psi | 240 | — | 375 | — | 240 | ±2.0 | ±3.0 | ±4.5 | ±1.0 | ±0.5 | A |
| 015PD | -15 | 15 | psi | 240 | — | 375 | — | 240 | ±2.0 | ±3.0 | ±4.5 | ±1.0 | ±0.5 | A |
| 030PD | -30 | 30 | psi | 240 | — | 375 | — | 240 | ±2.0 | ±3.0 | ±4.5 | ±1.0 | ±0.5 | A |
| 060PD | -60 | 60 | psi | 240 | — | 375 | — | 240 | ±2.0 | ±3.0 | ±4.5 | ±1.0 | ±0.5 | A |
| Gage | | | | | | | | | | | | | | |
| 015PG | 0 | 15 | psi | 240 | — | 375 | — | — | ±2.0 | ±3.0 | ±4.5 | ±1.0 | ±0.5 | A |
| 030PG | 0 | 30 | psi | 240 | — | 375 | — | — | ±2.0 | ±3.0 | ±4.5 | ±1.0 | ±0.5 | A |
| 060PG | 0 | 60 | psi | 240 | — | 375 | — | — | ±2.0 | ±3.0 | ±4.5 | ±1.0 | ±0.5 | A |
| 100PG | 0 | 100 | psi | 240 | — | 375 | — | — | ±2.0 | ±3.0 | ±4.5 | ±1.0 | ±0.5 | A |
| 150PG | 0 | 150 | psi | 240 | — | 375 | — | — | ±2.0 | ±3.0 | ±4.5 | ±1.0 | ±0.5 | A |
| 175PG | 0 | 175 | psi | 240 | — | 375 | — | — | ±2.0 | ±3.0 | ±4.5 | ±1.0 | ±0.5 | A |

¹ **Overpressure:** The maximum pressure which may safely be applied to the product for it to remain in specification once pressure is returned to the operating pressure range. Exposure to higher pressures may cause permanent damage to the product. Unless otherwise specified, this applies to all available pressure ports at any temperature within the operating temperature range.

² **Burst Pressure:** The maximum pressure that may be applied to any port of the product without causing escape of pressure media. The product should not be expected to function after exposure to any pressure beyond the burst pressure.

³ **Common Mode Pressure:** The maximum pressure that can be applied simultaneously to both ports of a differential pressure sensor without causing changes in specified performance.

⁴ **Total Error Band:** The maximum deviation from the ideal transfer function over the entire compensated temperature and pressure range without causing changes in specified performance.

ABP2 SERIES BASIC BOARD MOUNT PRESSURE SENSORS

DIMENSIONAL DRAWINGS

FIGURE 9. DIP PACKAGE DIMENSIONAL DRAWINGS (FOR REFERENCE ONLY: MM [IN.])

DIP NN: Plastic no port



DIP AN: Plastic single axial barbed port

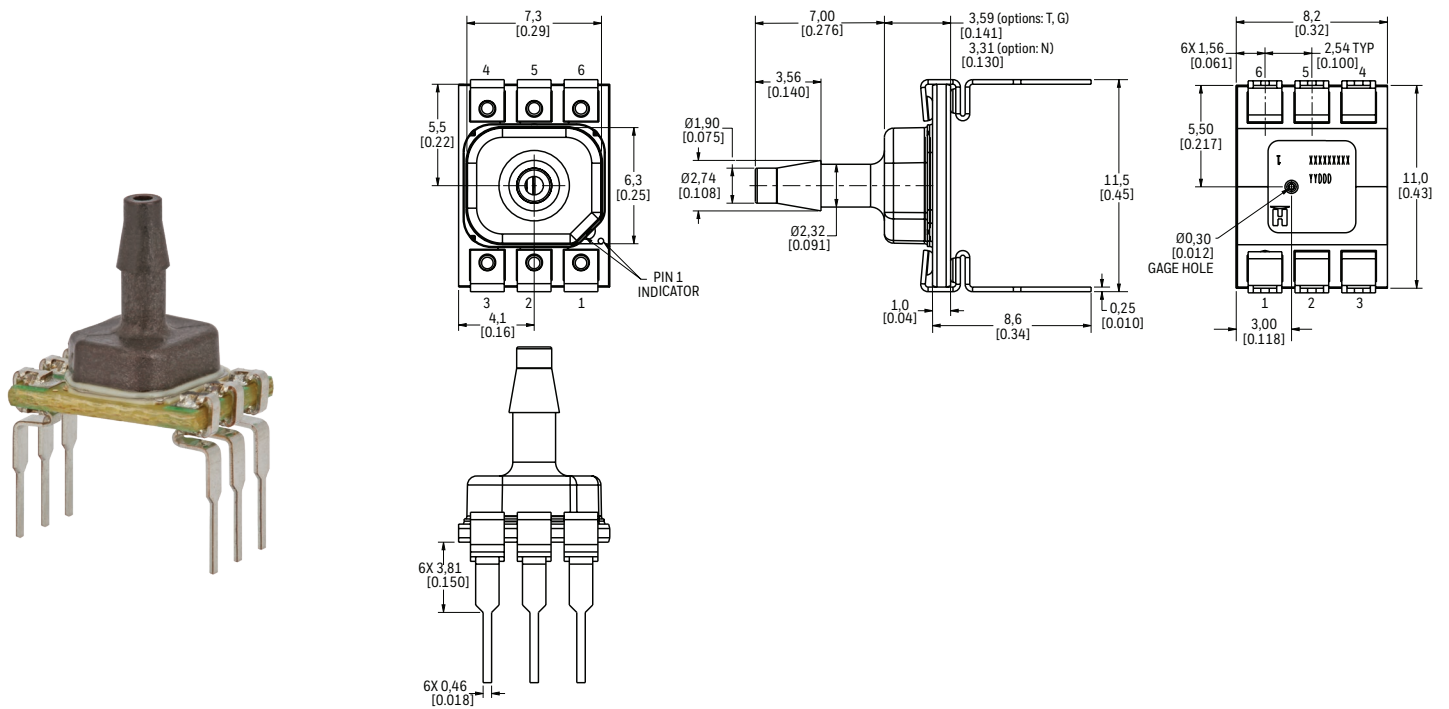

ABP2 SERIES BASIC BOARD MOUNT PRESSURE SENSORS

FIGURE 9. DIP PACKAGE DIMENSIONAL DRAWINGS (CONTINUED)

DIP VN: Metal single axial barbless port



DIP SN: Metal single axial straight barbless port

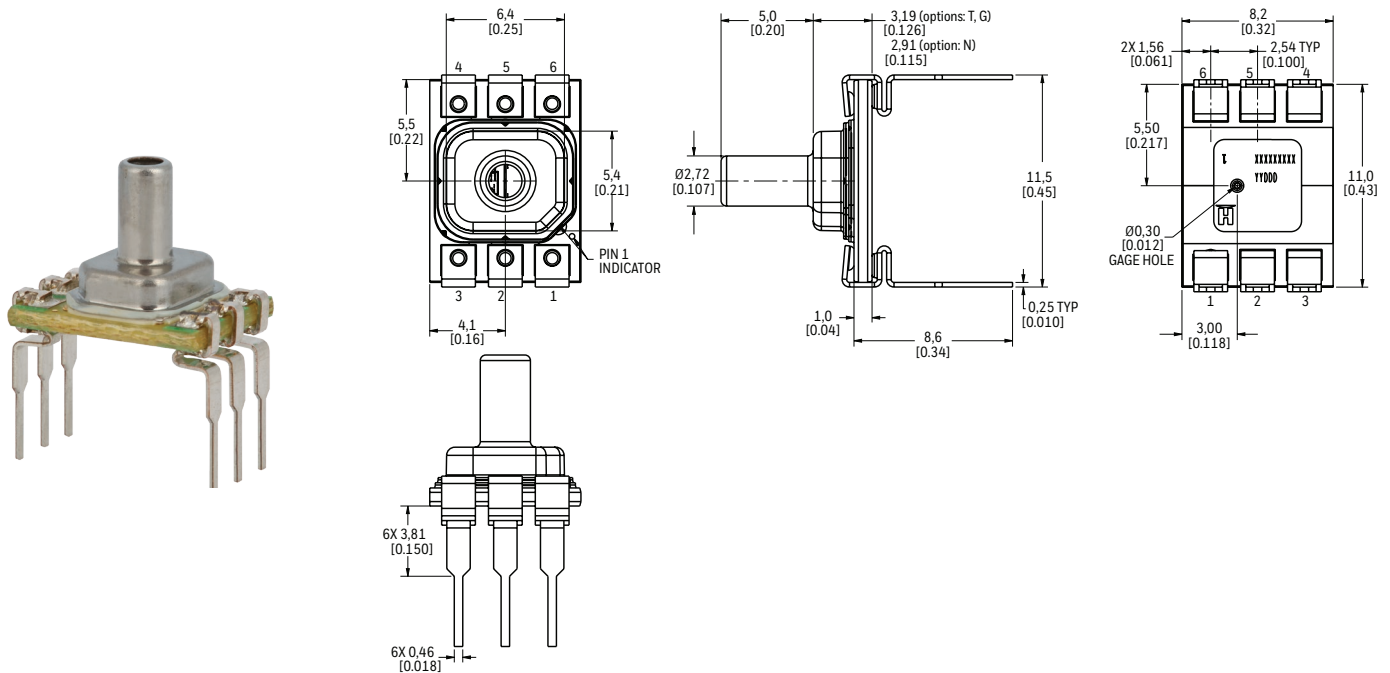

ABP2 SERIES BASIC BOARD MOUNT PRESSURE SENSORS

FIGURE 9. DIP PACKAGE DIMENSIONAL DRAWINGS (CONTINUED)

DIP RN: Plastic single radial barbed port

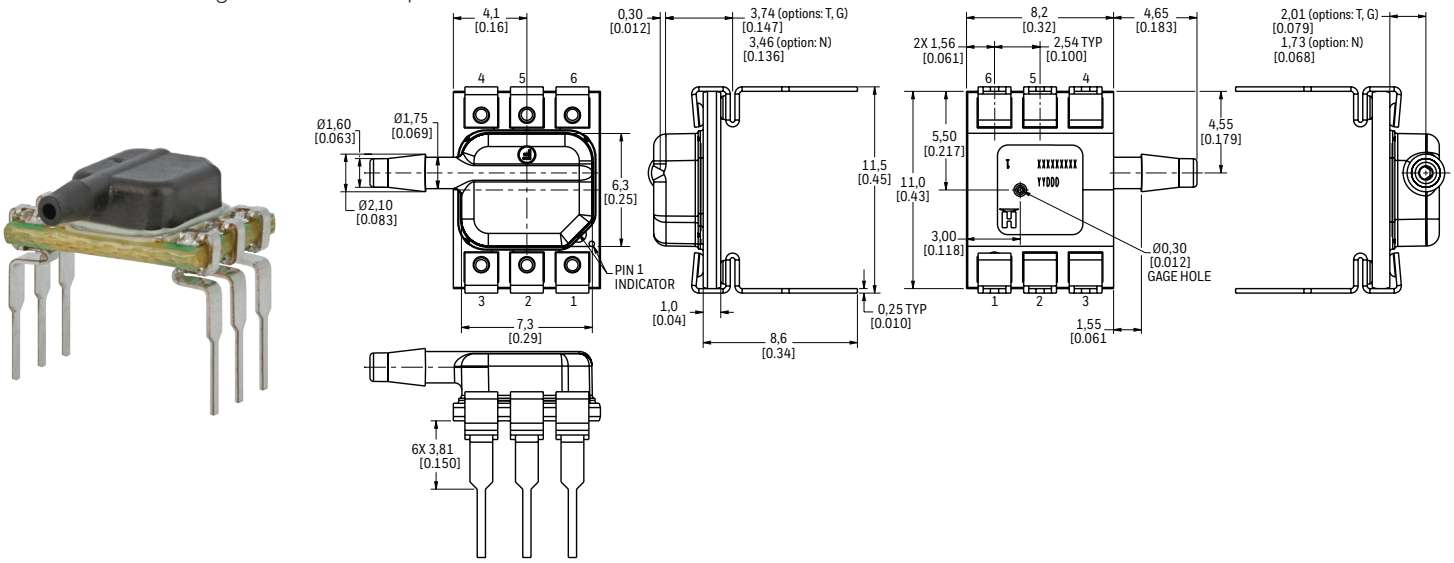

DIP RR: Plastic dual radial barbed ports, same side

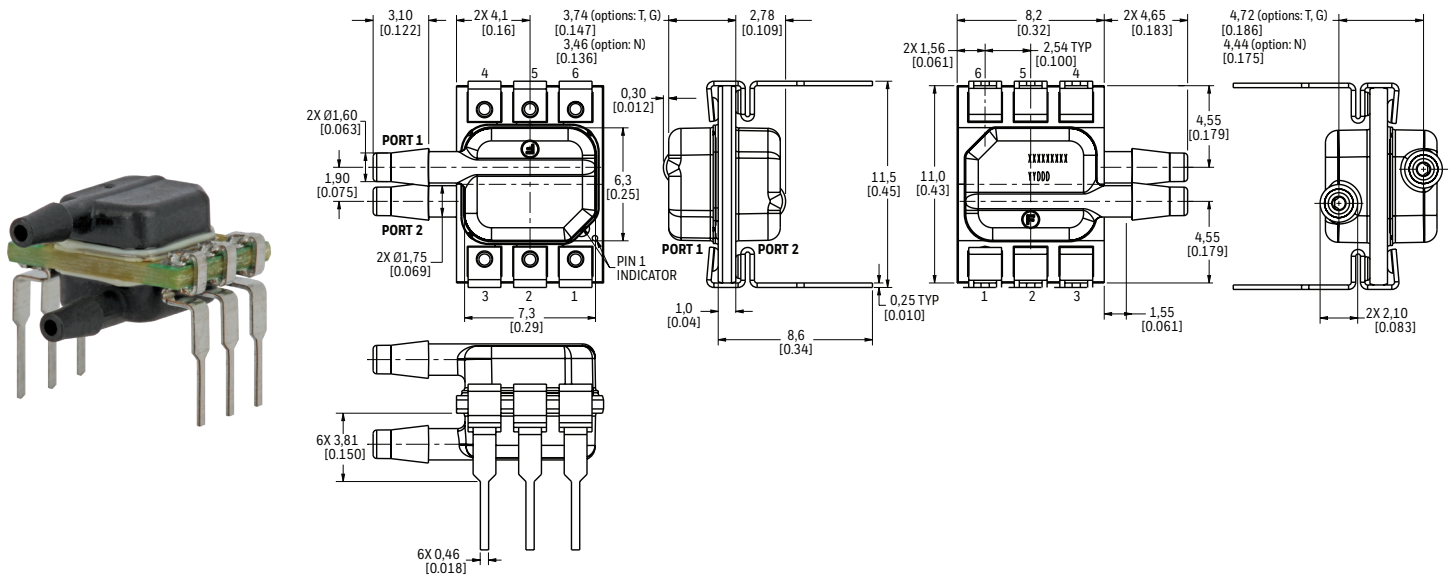

DIP DA: Plastic dual axial barbed ports, same side

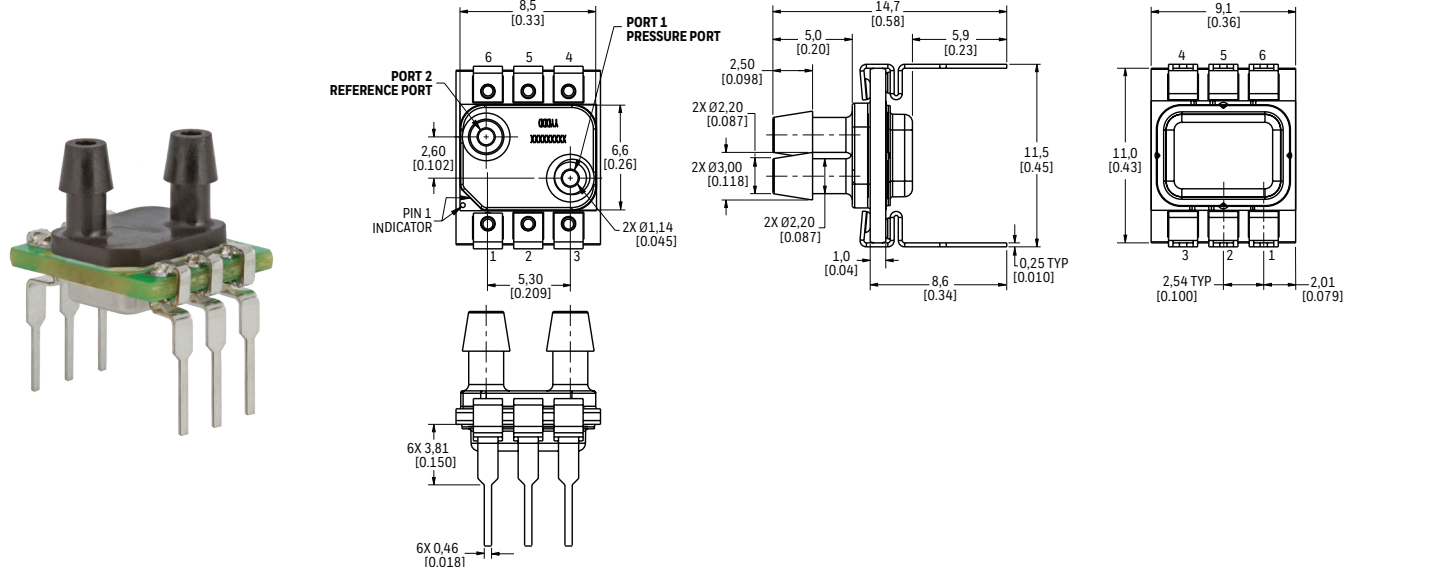

ABP2 SERIES BASIC BOARD MOUNT PRESSURE SENSORS

FIGURE 10. SMT PACKAGE DIMENSIONAL DRAWINGS (FOR REFERENCE ONLY: MM [IN.])

SMT NN: Plastic no port



SMT AN: Plastic single axial barbed port

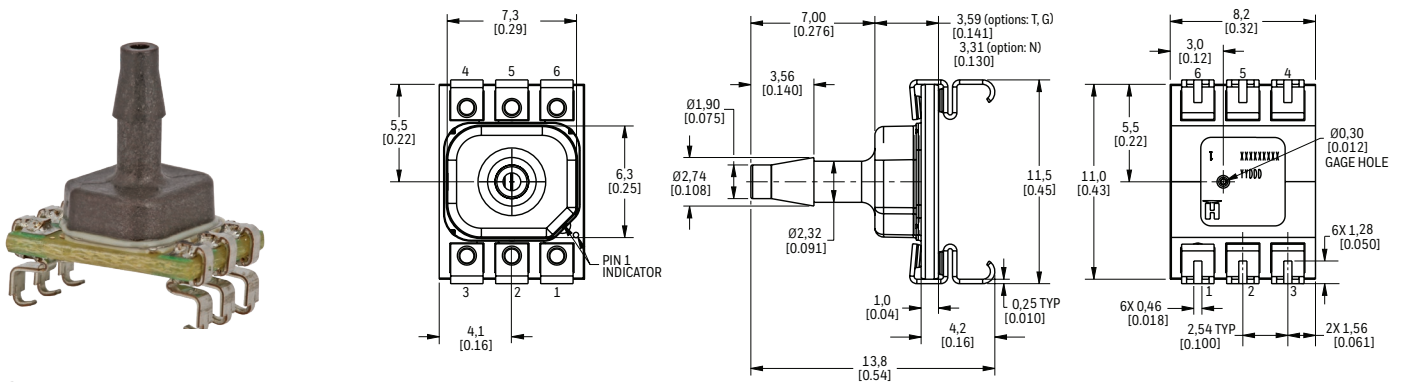

SMT VN: Metal single axial barbless port

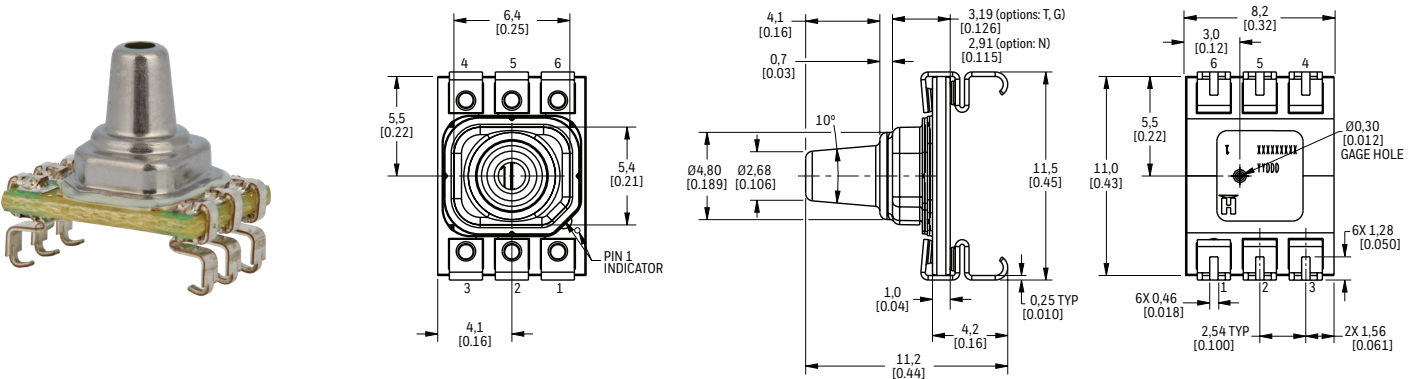

SMT SN: Metal single axial straight barbless port

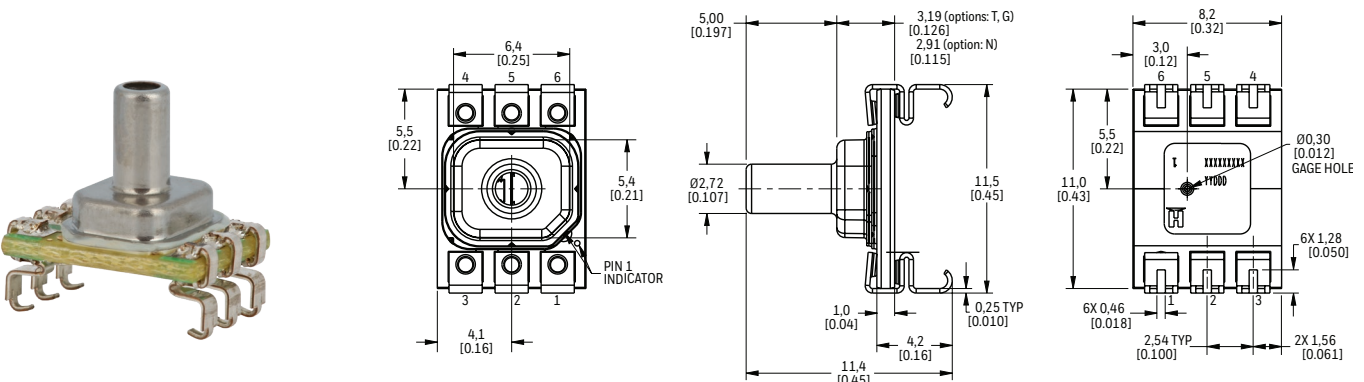

ABP2 SERIES BASIC BOARD MOUNT PRESSURE SENSORS

FIGURE 10. SMT PACKAGE DIMENSIONAL DRAWINGS (CONTINUED)

SMT RN: Plastic single radial barbed port



SMT RR: Plastic dual radial barbed ports, same side



SMT DA: Plastic dual axial barbed ports, same side

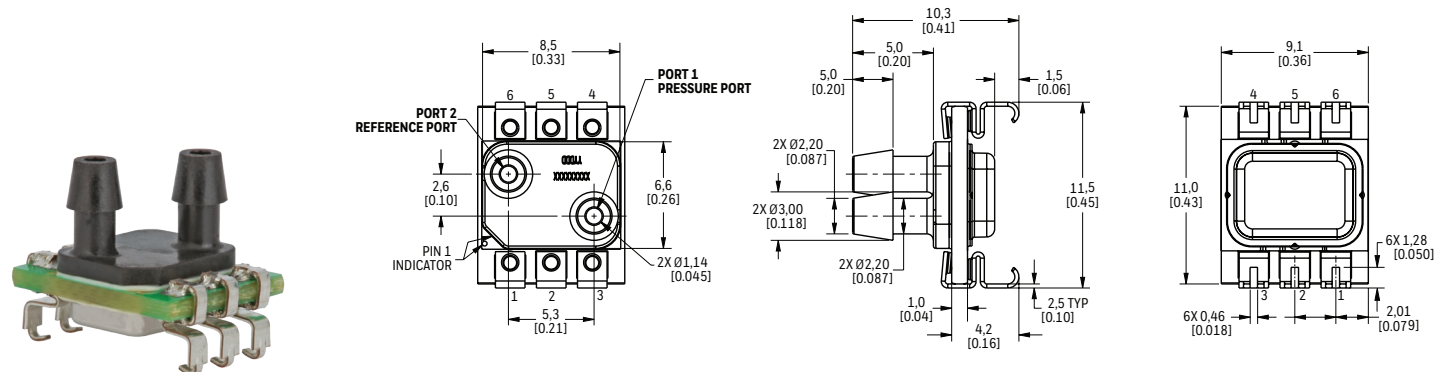

ABP2 SERIES BASIC BOARD MOUNT PRESSURE SENSORS

FIGURE 11. LEADLESS SMT PACKAGE DIMENSIONAL DRAWINGS (FOR REFERENCE ONLY: MM [IN.])

LEADLESS SMT NN: Plastic no port

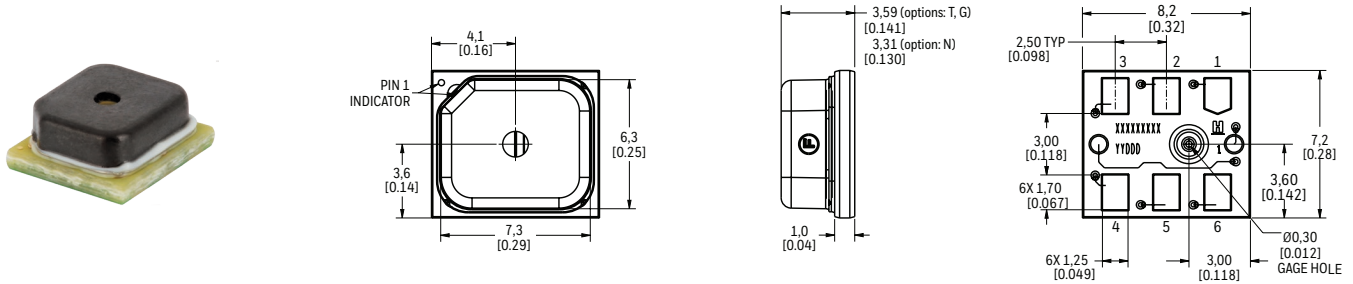

LEADLESS SMT AN: Plastic single axial barbed port

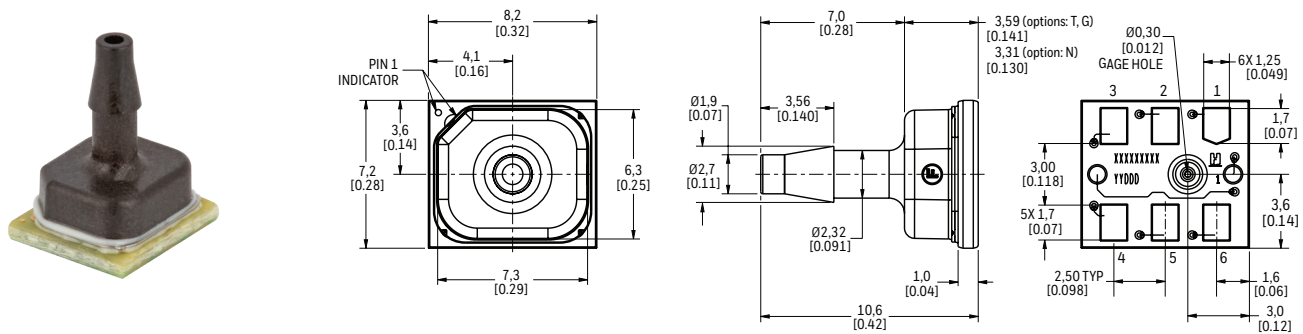

LEADLESS SMT VN: Metal single axial barbless port

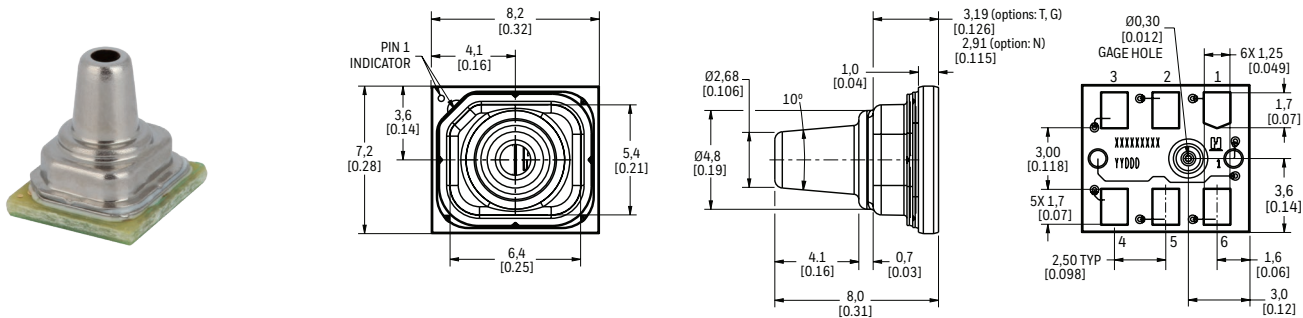

LEADLESS SMT SN: Metal single axial straight port

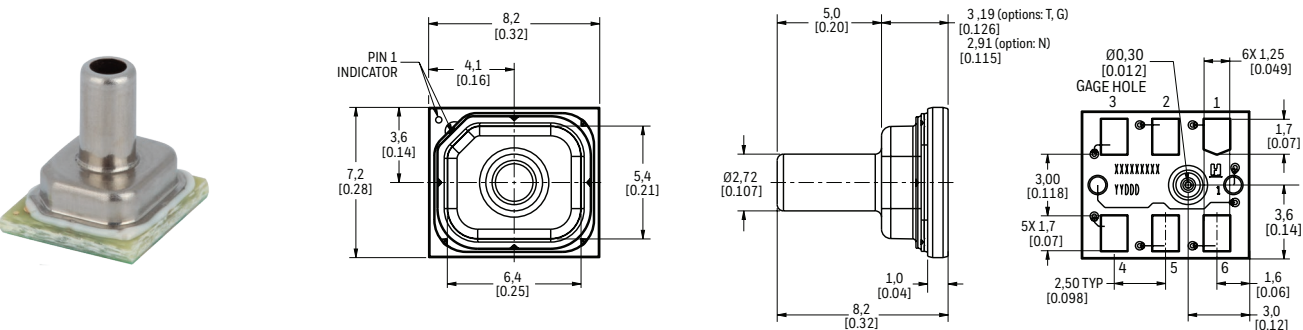

ABP2 SERIES BASIC BOARD MOUNT PRESSURE SENSORS

TABLE 19. PINOUT

| OUTPUT TYPE | PIN 1 | PIN 2 | PIN 3 | PIN 4 | PIN 5 | PIN 6 |
|------------------|-------|-----------------|------------------|-------|-------|-----------------|
| I ² C | GND | V _{DD} | EOC | NC | SDA | SCL |
| SPI | GND | V _{DD} | MISO | SS | MOSI | SCLK |
| analog | GND | NC | V _{OUT} | NC | NC | V _{DD} |

FIGURE 12. RECOMMENDED PCB LAYOUT AND PART MARKING DETAILS

DIP Packages
All pressure port styles except DA



SMT Packages
All pressure port styles except DA

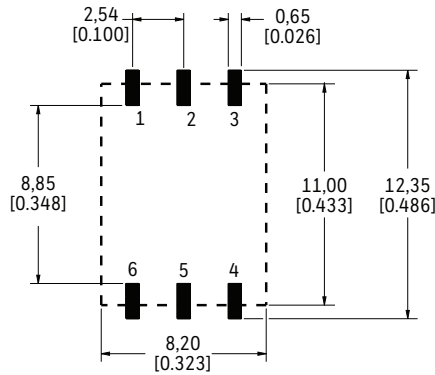

Leadless SMT Packages
All pressure port styles



DIP Packages
Pressure port style DA only

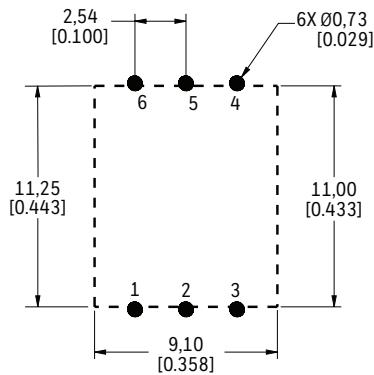

DMT Packages
Pressure port style DA only

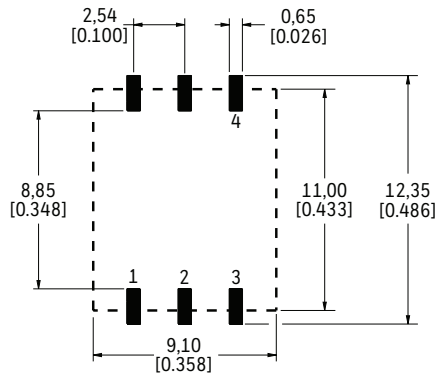

Part Marking Details



CATALOG LISTING: 'XXXXXXXX'
 EXAMPLE: N010BAA3
 N - DRY GASES ONLY NO DIAGNOSTICS, 010B - 10bar, A - ABSOLUTE, A - ANALOG,
 A - 10% to 90% of 2²⁴ COUNTS (DIGITAL). 3 - 3.3Vdc
 DATE CODE: 'YYDDD'
 EXAMPLE: 19215
 19 - YY - YEAR, 215 - DDD - JULIAN DAY.

ABP2 SERIES BASIC BOARD MOUNT PRESSURE SENSORS

1.0 GENERAL INFORMATION

Please see Figures 7, 8, and 9 for product dimensions and pinout details.

2.0 PINOUT AND FUNCTIONALITY

TABLE 20. PINOUT AND FUNCTIONALITY

| PAD NUMBER | I ² C SENSOR | | SPI SENSOR | |
|------------|-------------------------|--|-----------------|-----------------------------------|
| | NAME | DESCRIPTION | NAME | DESCRIPTION |
| 1 | GND | Ground reference voltage signal | GND | Ground reference voltage signal |
| 2 | V _{DD} | Positive supply voltage | V _{DD} | Positive supply voltage |
| 3 | EOC ¹ | End-of-conversion indicator: This pin is set high when a measurement and calculation have been completed and the data is ready to be clocked out | MISO | Master In/Sensor Out: Data output |
| 4 | NC | No connection | SS | Sensor Select: Chip select |
| 5 | SDA | Data in/out | MOSI | Master Out/Sensor In: Data in |
| 6 | SCL | Clock input | SCLK | Clock input |

¹ For more details on EOC functionality, please refer to the technical note.

3.0 START-UP TIMING

On power-up, the ABP2 Series digital sensor is able to receive the first command after 2.5 ms from when the V_{DD} supply is within operating specifications.

4.0 POWER SUPPLY REQUIREMENT

Verify that system power to the sensor meets the V_{DD} rising slope requirement (minimum V_{DD} rising slope is at least 10 V/ms).

ABP2 SERIES BASIC BOARD MOUNT PRESSURE SENSORS

5.0 REFERENCE CIRCUIT DESIGNS

5.1 DIGITAL OUTPUT VERSIONS

FIGURE 13. I²C/SPI CIRCUIT DIAGRAM

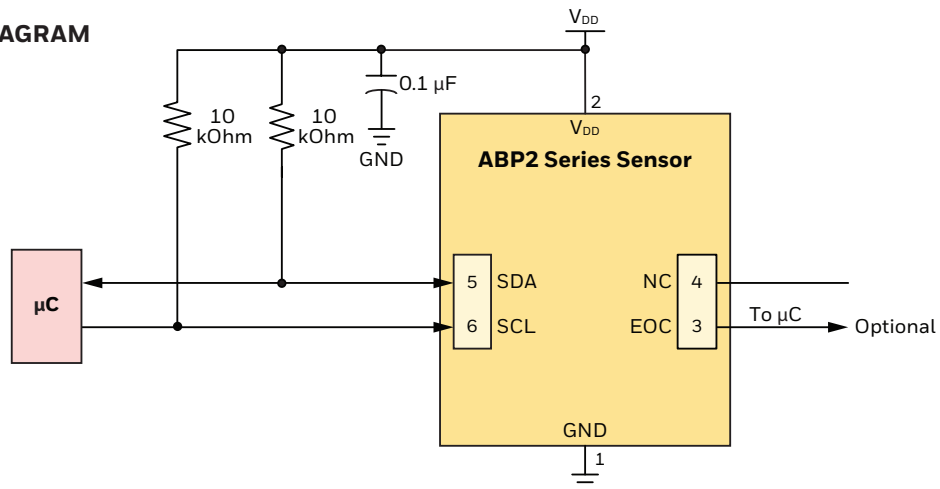
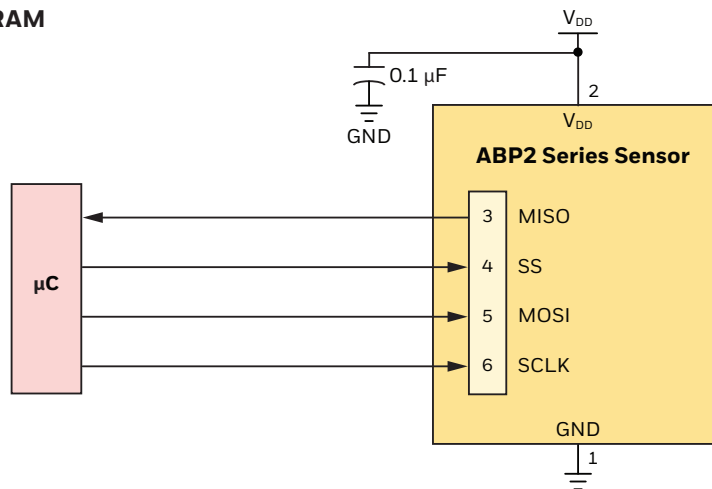
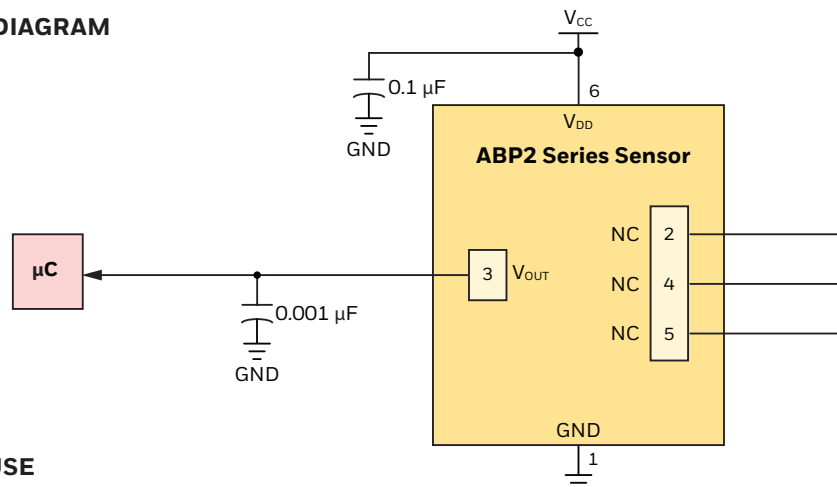

FIGURE 14. SPI CIRCUIT DIAGRAM



5.2 ANALOG OUTPUT VERSIONS

FIGURE 15. ANALOG CIRCUIT DIAGRAM



5.3 BYPASS CAPACITOR USE

NOTICE

To ensure output noise suppression, place an external bypass capacitor of 0.1 μF very close to the sensor power supply pin (see Figures 13 and 14) in the end-user design.

ABP2 SERIES BASIC BOARD MOUNT PRESSURE SENSORS

6.0 I²C COMMUNICATIONS

6.1 I²C BUS CONFIGURATION (SEE FIGURE 16.)

The I²C bus is a simple, serial 8-bit oriented computer bus for efficient I²C (Inter-IC) control. It provides good support for communication between different ICs across short circuit-board distances, such as interfacing microcontrollers with various low speed peripheral devices. For detailed specifications of the I²C protocol, see Version 6 (April 2014) of the I²C Bus Specification (source: NXP Semiconductor at <https://www.nxp.com/docs/en/user-guide/UM10204.pdf>).

Each device connected to the bus is software addressable by a unique address and a simple Master/Sensor relationship that exists at all times. The output stages of devices connected to the bus are designed around an open collector architecture. Because of this, pull-up resistors to +V_{DD} must be provided on the bus. Both SDA and SCL are bidirectional lines, and it is important to system performance to match the capacitive loads on both lines. In addition, in accordance with the I²C specification, the maximum allowable capacitance on either line is 400 pF to ensure reliable edge transitions at 400 kHz clock speeds.

When the bus is free, both lines are pulled up to +V_{DD}. Data on the I²C bus can be transferred at a rate up to 100 kbit/s in the standard-mode, or up to 400 kbit/s in the fast-mode.

FIGURE 16. I²C BUS CONFIGURATION

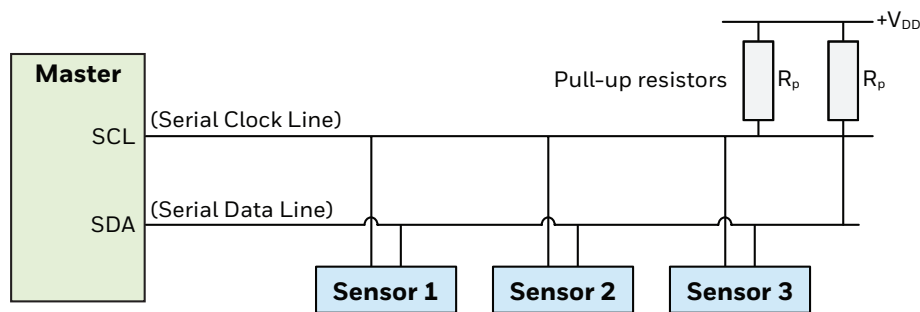

6.2 I²C DATA TRANSFER

The ABP2 Series I²C sensors are designed to respond to requests from a Master device. Following the address and read bit from the Master, the ABP2 Series digital output pressure sensors are designed to output up to 7 bytes of data. The first data byte is the Status Byte (8 bit), the second to fourth bytes are the compensated pressure output (24 bit) and the fifth to seventh bytes are the compensated temperature output (24 bit).

6.3 I²C SENSOR ADDRESS

Each ABP2 Series I²C sensor is referenced on the bus by a 7-bit Sensor address. The default address for the ABP2 Series is 40 (28 hex). Other available standard addresses are: 08 (08 hex), 24 (18 hex), 56 (38 hex), 72 (48 hex), 88 (58 hex), 104 (68 hex), 120 (78 hex). (Other custom values are available. Please contact Honeywell Customer Service with questions regarding custom Sensor addresses.)

6.4 I²C PRESSURE AND TEMPERATURE READING

To read out the compensated pressure and temperature reading, the Master generates a START condition and sends the Sensor address followed by a read bit (1). After the Sensor generates an acknowledge, it will transmit up to 7 bytes of data. The first data byte is the Status Byte (8-bit) and the second to fourth bytes are the compensated pressure output (24 bit) and the fifth to seventh bytes are the compensated temperature output (24 bit). The Master must acknowledge the receipt of each byte, and can terminate the communication by sending a Not Acknowledge (NACK) bit followed by a Stop bit after receiving the required bytes of data.

ABP2 SERIES BASIC BOARD MOUNT PRESSURE SENSORS

6.5 I²C STATUS BYTE

TABLE 21. I²C STATUS BYTE EXPLANATION

| BIT (MEANING) | STATUS | COMMENT |
|---------------------------------|--|---|
| 7 | always 0 | — |
| 6 (Power indication) | 1 = device is powered 0 = device is not powered | — |
| 5 (Busy flag) | 1 = device is busy | Indicates that the data for the last command is not yet available. No new commands are processed if the device is busy. |
| 4 | always 0 | — |
| 3 | always 0 | — |
| 2 (Memory integrity/error flag) | 0 = integrity test passed 1 = integrity test failed | Indicates whether the checksum-based integrity check passed or failed; the memory error status bit is calculated only during the power-up sequence. |
| 1 | always 0 | — |
| 0 (Math saturation) | 1 = internal math saturation has occurred | — |

6.6 I²C COMMUNICATIONS

6.6.1 I²C OUTPUT MEASUREMENT COMMAND

To communicate with the ABP2 Series I²C output sensor using an Output Measurement Command of “0xAA”, followed by “0x00” “0x00”, follow the steps shown in Table 22. This command will cause the device to exit Standby Mode and enter Operating Mode. At the conclusion of the measurement cycle, the device will automatically re-enter Standby Mode.

TABLE 22. I²C OUTPUT MEASUREMENT COMMAND

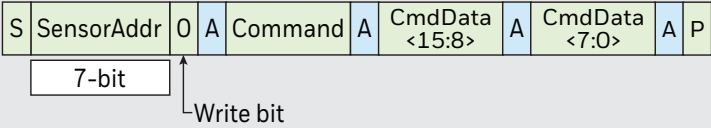
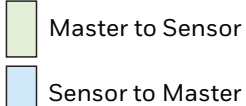
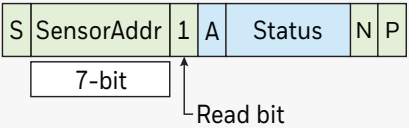
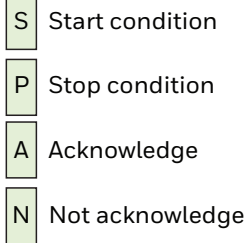
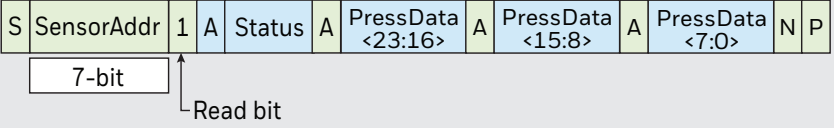
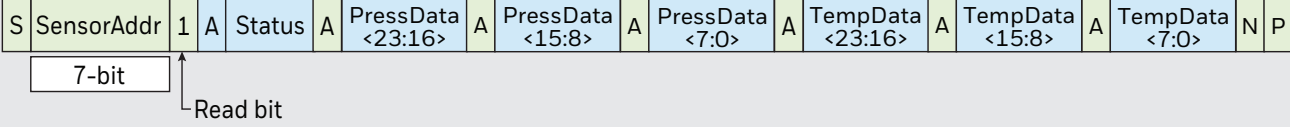
| STEP | ACTION | NOTES |
|------|--|---|
| 1 |  <p>Write bit</p> |  <ul style="list-style-type: none"> Master to Sensor Sensor to Master |
| 2 | <p>Option 1: Wait until the busy flag in the Status Byte clears.</p> <p>Option 2: Wait for at least 5 ms for the data conversion to occur.</p> <p>Option 3: Wait for the EOC indicator.</p>  <p>Read bit</p> |  <ul style="list-style-type: none"> S Start condition P Stop condition A Acknowledge N Not acknowledge |
| 3 | <p>To read only the 24-bit pressure output along with the 8-bit Status Byte:</p>  <p>Read bit</p> <p>To read the 24-bit pressure output and 24-bit temperature output along with the 8-bit Status Byte:</p>  <p>Read bit</p> | |

ABP2 SERIES BASIC BOARD MOUNT PRESSURE SENSORS

6.6.2 I²C SENSOR ADDRESS OF 0X28

To communicate with the ABP2 Series I²C output sensor with an I²C Sensor Address of 0x28 (hex), follow the steps shown in Table 23.

TABLE 23. I²C SENSOR ADDRESS OF 0X28 COMMUNICATIONS

| STEP | ACTION | NOTES |
|------|---|---|
| 1 | <p>Option 1: Wait until the busy flag in the Status Byte clears.</p> <p>Option 2: Wait for at least 5 ms for the data conversion to occur.</p> <p>Option 3: Wait for the EOC indicator.</p> | <ul style="list-style-type: none"> Master to Sensor Sensor to Master S Start condition P Stop condition A Acknowledge N Not acknowledge |
| 2 | <p>Option 1: Wait until the busy flag in the Status Byte clears.</p> <p>Option 2: Wait for at least 5 ms for the data conversion to occur.</p> <p>Option 3: Wait for the EOC indicator.</p> | <ul style="list-style-type: none"> S Start condition P Stop condition A Acknowledge N Not acknowledge |
| 3 | <p>To read the 24-bit pressure output along with the 8-bit Status Byte:</p> <p>To read the 24-bit pressure output and the 24-bit temperature output along with the 8-bit Status Byte:</p> | |

6.7 I²C TIMING AND LEVEL PARAMETERS

TABLE 24. I²C BUS TIMING DIAGRAM AND PARAMETERS



| CHARACTERISTIC | ABBREVIATION | MIN. | TYP. | MAX. | UNIT |
|--|--------------|------|------|------|----------|
| SCL clock frequency | f_{SCL} | 100 | — | 400 | kHz |
| Start condition hold time relative to SCL edge | t_{HDSTA} | 0.1 | — | — | μ s |
| Minimum SCL clock low width ¹ | t_{LOW} | 0.6 | — | — | μ s |
| Minimum SCL clock high width ¹ | t_{HIGH} | 0.6 | — | — | μ s |
| Start condition setup time relative to SCL edge | t_{SUSTA} | 0.1 | — | — | μ s |
| Data hold time on SDA relative to SCL edge | t_{HDDAT} | 0 | — | — | μ s |
| Data setup time on SDA relative to SCL edge | t_{SUDAT} | 0.1 | — | — | μ s |
| Stop condition setup time on SCL | t_{SUSTO} | 0.1 | — | — | μ s |
| Bus free time between stop condition and start condition | t_{BUS} | 2 | — | — | μ s |
| Output level low | Out_{low} | — | 0 | 0.2 | V_{DD} |
| Output level high | Out_{high} | 0.8 | 1 | — | V_{DD} |
| Pull-up resistance on SDA and SCL | R_p | 1 | — | 50 | kOhm |

¹ Combined low and high widths must equal or exceed minimum SCL period.

ABP2 SERIES BASIC BOARD MOUNT PRESSURE SENSORS

6.8 REFERENCE CODE (ARDUINO/GENUINO UNO) FOR I²C INTERFACE

See also Section 8.0 for details and examples of ABP2 Series Pressure and Temperature output calculations.

```
#include<Arduino.h>
#include<Wire.h>

uint8_t id = 0x28; // i2c address
uint8_t data[7]; // holds output data
uint8_t cmd[3] = {0xAA, 0x00, 0x00}; // command to be sent
double press_counts = 0; // digital pressure reading [counts]
double temp_counts = 0; // digital temperature reading [counts]
double pressure = 0; // pressure reading [bar, psi, kPa, etc.]
double temperature = 0; // temperature reading in deg C
double outputmax = 15099494; // output at maximum pressure [counts]
double outputmin = 16777215; // output at minimum pressure [counts]
double pmax = 1; // maximum value of pressure range [bar, psi, kPa, etc.]
double pmin = 0; // minimum value of pressure range [bar, psi, kPa, etc.]
double percentage = 0; // holds percentage of full scale data
char printBuffer[200], cBuff[20], percBuff[20], pBuff[20], tBuff[20];
void setup() {
  Serial.begin(9600);
  while (!Serial) {
    delay(10);
  }
  Wire.begin();
  sprintf(printBuffer, "\nStatus Register, 24 - bit Sensor data, Digital Pressure Counts,\
  Percentage of full scale pressure, Pressure Output, Temperature\n");
  Serial.println(printBuffer);
}
void loop() {
  Wire.beginTransmission(id);
  int stat = Wire.write(cmd, 3); // write command to the sensor
  stat |= Wire.endTransmission();
  delay(10);
  Wire.requestFrom(id, 7); // read back Sensor data 7 bytes
  int i = 0;
  for (i = 0; i < 7; i++) {
    data[i] = Wire.read();
  }
  press_counts = data[3] + data[2] * 256 + data[1] * 65536; // calculate digital pressure counts
  temp_counts = data[6] + data[5] * 256 + data[4] * 65536; // calculate digital temperature counts
  temperature = (temp_counts * 200 / 16777215) - 50; // calculate temperature in deg c
  percentage = (press_counts / 16777215) * 100; // calculate pressure as percentage of full scale
  //calculation of pressure value according to equation 2 of datasheet
  pressure = ((press_counts - outputmin) * (pmax - pmin)) / (outputmax - outputmin) + pmin;
  dtostrf(press_counts, 4, 1, cBuff);
  dtostrf(percentage, 4, 3, percBuff);
  dtostrf(pressure, 4, 3, pBuff);
  dtostrf(temperature, 4, 3, tBuff);
  /*
  The below code prints the raw data as well as the processed data
  Data format : Status Register, 24-bit Sensor Data, Digital Counts, percentage of full scale
  pressure,
  pressure output, temperature
  */
  sprintf(printBuffer, " %x\t %2x %2x %2x\t %s\t %s\t %s\t %s\n", data[0], data[1], data[2],
    data[3],
    cBuff, percBuff, pBuff, tBuff);
  Serial.print(printBuffer);
  delay(10);
}
```

ABP2 SERIES BASIC BOARD MOUNT PRESSURE SENSORS

7.0 SPI COMMUNICATIONS

7.1 SPI DEFINITION

The Serial Peripheral Interface (SPI) is a simple bus system for synchronous serial communication between one Master and one or more Sensors. It operates either in full-duplex or half-duplex mode, allowing communication to occur in either both directions simultaneously, or in one direction only. The Master device initiates an information transfer on the bus and generates clock and control signals. Sensor devices are controlled by the Master through individual Sensors Select (SS) lines and are active only when selected. The ABP2 Series SPI sensors operate in full-duplex mode only, with data transfer from the Sensors to the Master. This data transmission uses four, unidirectional bus lines. The Master controls SCLK, MOSI and SS; the Sensor controls MISO. (See Figure 17.)

FIGURE 17. SPI BUS CONFIGURATION

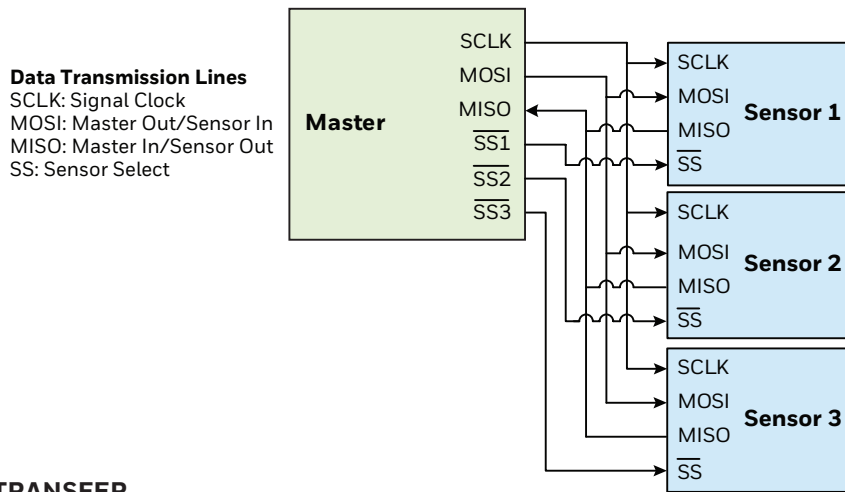

7.2 SPI DATA TRANSFER

Communicate with the ABP2 Series SPI sensors by de-asserting the Sensor Select (SS) line. At this point, the sensor is no longer idle, and will begin sending data once a clock is received. ABP2 Series SPI sensors are configured for SPI operation in mode 0 (clock polarity is 0 and clock phase is 0). (See Figure 18.)

FIGURE 18. EXAMPLE OF 1 BYTE SPI DATA TRANSFER

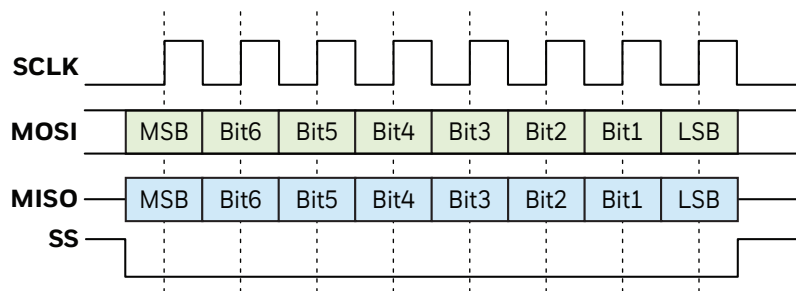

Once the clocking begins, the ABP2 Series SPI sensor is designed to output up to 7 bytes of data. The first data byte is the Status Byte (8-bit), the second to fourth bytes are the compensated pressure output (24-bit) and the fifth to seventh bytes are the compensated temperature output (24-bit).

7.3 SPI PRESSURE AND TEMPERATURE READING

To read out the compensated pressure and temperature reading, the Master generates the necessary clock signal after activating the sensor with the Sensor Select (SS) line. The sensor will transmit up to 7 bytes of data. The first data byte is the Status Byte (8-bit), the second to fourth bytes are the compensated pressure output (24-bit) and the fifth to seventh bytes are the compensated temperature output (24-bit). The Master can terminate the communication by stopping the clock and deactivating the SS line.

ABP2 SERIES BASIC BOARD MOUNT PRESSURE SENSORS

7.4 SPI STATUS BYTE

The SPI status byte contains the bits shown in Table 25.

TABLE 25. SPI STATUS BYTE EXPLANATION

| BIT (MEANING) | STATUS | COMMENT |
|---------------------------------|--|---|
| 7 | always 0 | — |
| 6 (Power indication) | 1 = device is powered 0 = device is not powered | — |
| 5 (Busy flag) | 1 = device is busy | Indicates that the data for the last command is not yet available. No new commands are processed if the device is busy. |
| 4 | always 0 | — |
| 3 | always 0 | — |
| 2 (Memory integrity/error flag) | 0 = integrity test passed 1 = integrity test failed | Indicates whether the checksum-based integrity check passed or failed; the memory error status bit is calculated only during the power-up sequence. |
| 1 | always 0 | — |
| 0 (Math saturation) | 1 = internal math saturation has occurred | — |

7.5 SPI COMMUNICATION

To communicate with the ABP2 Series SPI output sensor using an Output Measurement Command of “0xAA”, followed by “0x00” “0x00”, follow the steps shown in Table 26. This command will cause the device to exit Standby Mode and enter Operating Mode. At the conclusion of the measurement cycle, the device will automatically re-enter Standby Mode.

TABLE 26. SPI OUTPUT MEASUREMENT COMMAND

| STEP | ACTION | NOTES | | | | | | | | | | | | | | | | | | | | | | | | | | | | | | | | | |
|-------------|---|------------------------------|----------------------------------|-------------------|-------------------|--------------------------------|------------------------------|-------------------|-------------------|-------------|--|-------------------|----------------------------------|------|------|------|------|------|------|------|-------------|---------------|-------------------|-------------------|-------------------|-------------------|-------------------|-------------|--------|-------------------|------------------|-----------------|------------------|--------------------------------|--|
| 1 | <p>The data on MISO depend on the preceding command. Discard the data on the MISO line.</p> <table border="1"> <tr> <td>0xAA</td> <td>0x00</td> <td>0x00</td> </tr> <tr> <td>MOSI</td> <td>Measurement Command</td> <td>CmdData <15:8> CmdData <7:0></td> </tr> <tr> <td>MISO</td> <td>Status</td> <td>Data Data</td> </tr> </table> | 0xAA | 0x00 | 0x00 | MOSI | Measurement Command | CmdData <15:8> CmdData <7:0> | MISO | Status | Data Data | <p>Master to Sensor</p> <p>Sensor to Master</p> <ul style="list-style-type: none"> NOP Command is “0xF0”. | | | | | | | | | | | | | | | | | | | | | | | | |
| 0xAA | 0x00 | 0x00 | | | | | | | | | | | | | | | | | | | | | | | | | | | | | | | | | |
| MOSI | Measurement Command | CmdData <15:8> CmdData <7:0> | | | | | | | | | | | | | | | | | | | | | | | | | | | | | | | | | |
| MISO | Status | Data Data | | | | | | | | | | | | | | | | | | | | | | | | | | | | | | | | | |
| 2 | <p>Option 1: Wait until the busy flag in the Status Byte clears. Option 2: Wait for at least 5 ms for the data conversion to occur.</p> <table border="1"> <tr> <td>0xF0</td> </tr> <tr> <td>MOSI</td> <td>Command = NOP</td> </tr> <tr> <td>MISO</td> <td>Status</td> </tr> </table> | 0xF0 | MOSI | Command = NOP | MISO | Status | | | | | | | | | | | | | | | | | | | | | | | | | | | | | |
| 0xF0 | | | | | | | | | | | | | | | | | | | | | | | | | | | | | | | | | | | |
| MOSI | Command = NOP | | | | | | | | | | | | | | | | | | | | | | | | | | | | | | | | | | |
| MISO | Status | | | | | | | | | | | | | | | | | | | | | | | | | | | | | | | | | | |
| 3 | <p>To read only the 24-bit pressure output along with the 8-bit Status Byte:</p> <table border="1"> <tr> <td>0xF0</td> <td>0x00</td> <td>0x00</td> <td>0x00</td> </tr> <tr> <td>MOSI</td> <td>Command = NOP</td> <td>00_{Hex}</td> <td>00_{Hex}</td> </tr> <tr> <td>MISO</td> <td>Status</td> <td>PressData <24:16></td> <td>PressData <15:8> PressData <7:0></td> </tr> </table> <p>To read the 24-bit pressure output and the 24-bit temperature output along with the 8-bit Status Byte:</p> <table border="1"> <tr> <td>0xF0</td> <td>0x00</td> <td>0x00</td> <td>0x00</td> <td>0x00</td> <td>0x00</td> <td>0x00</td> </tr> <tr> <td>MOSI</td> <td>Command = NOP</td> <td>00_{Hex}</td> <td>00_{Hex}</td> <td>00_{Hex}</td> <td>00_{Hex}</td> <td>00_{Hex}</td> </tr> <tr> <td>MISO</td> <td>Status</td> <td>PressData <24:16></td> <td>PressData <15:8></td> <td>PressData <7:0></td> <td>TempData <24:16></td> <td>TempData <15:8> TempData <7:0></td> </tr> </table> | 0xF0 | 0x00 | 0x00 | 0x00 | MOSI | Command = NOP | 00 _{Hex} | 00 _{Hex} | MISO | Status | PressData <24:16> | PressData <15:8> PressData <7:0> | 0xF0 | 0x00 | 0x00 | 0x00 | 0x00 | 0x00 | 0x00 | MOSI | Command = NOP | 00 _{Hex} | 00 _{Hex} | 00 _{Hex} | 00 _{Hex} | 00 _{Hex} | MISO | Status | PressData <24:16> | PressData <15:8> | PressData <7:0> | TempData <24:16> | TempData <15:8> TempData <7:0> | |
| 0xF0 | 0x00 | 0x00 | 0x00 | | | | | | | | | | | | | | | | | | | | | | | | | | | | | | | | |
| MOSI | Command = NOP | 00 _{Hex} | 00 _{Hex} | | | | | | | | | | | | | | | | | | | | | | | | | | | | | | | | |
| MISO | Status | PressData <24:16> | PressData <15:8> PressData <7:0> | | | | | | | | | | | | | | | | | | | | | | | | | | | | | | | | |
| 0xF0 | 0x00 | 0x00 | 0x00 | 0x00 | 0x00 | 0x00 | | | | | | | | | | | | | | | | | | | | | | | | | | | | | |
| MOSI | Command = NOP | 00 _{Hex} | 00 _{Hex} | 00 _{Hex} | 00 _{Hex} | 00 _{Hex} | | | | | | | | | | | | | | | | | | | | | | | | | | | | | |
| MISO | Status | PressData <24:16> | PressData <15:8> | PressData <7:0> | TempData <24:16> | TempData <15:8> TempData <7:0> | | | | | | | | | | | | | | | | | | | | | | | | | | | | | |

ABP2 SERIES BASIC BOARD MOUNT PRESSURE SENSORS

7.6 SPI TIMING AND LEVEL PARAMETERS

TABLE 27. SPI BUS TIMING DIAGRAM AND PARAMETERS



| CHARACTERISTIC | ABBREVIATION | MIN. | TYP. | MAX. | UNIT |
|--|--------------|------|------|------|----------|
| SCLK clock frequency | f_{SCLK} | 50 | — | 800 | kHz |
| SS drop to first clock edge | t_{HDSS} | 2.5 | — | — | μ s |
| Minimum SCLK clock low width ¹ | t_{LOW} | 0.6 | — | — | μ s |
| Minimum SCLK clock high width ¹ | t_{HIGH} | 0.6 | — | — | μ s |
| Clock edge to data transition | t_{CLKD} | 0 | — | — | μ s |
| Rise of SS relative to last clock edge | t_{SUSS} | 0.1 | — | — | μ s |
| Bus free time between rise and fall of SS | t_{BUS} | 2 | — | — | μ s |
| Output level low | Out_{low} | — | 0 | 0.2 | V_{DD} |
| Output level high | Out_{high} | 0.8 | 1 | — | V_{DD} |

¹Combined low and high widths must equal or exceed minimum SCLK period.

ABP2 SERIES BASIC BOARD MOUNT PRESSURE SENSORS

7.7 REFERENCE CODE (ARDUINO/GENUINO UNO) FOR SPI INTERFACE

See also Section 8.0 for details and examples of ABP2 Series Pressure and Temperature output calculations.

```
#include<Arduino.h>
#include<SPI.h>

double press_counts = 0; // digital pressure reading [counts]
double temp_counts = 0; // digital temperature reading [counts]
double pressure = 0; // pressure reading [bar, psi, kPa, etc.]
double temperature = 0; // temperature reading in deg C
double outputmax = 15099494; // output at maximum pressure [counts]
double outputmin = 1677722; // output at minimum pressure [counts]
double pmax = 1; // maximum value of pressure range [bar, psi, kPa, etc.]
double pmin = 0; // minimum value of pressure range [bar, psi, kPa, etc.]
double percentage = 0; // holds percentage of full scale data
char printBuffer[200], cBuff[20], percBuff[20], pBuff[20], tBuff[20];
void setup() {
  Serial.begin(9600);
  while (!Serial) {
    delay(10);
  }
  sprintf(printBuffer, "\nStatus Register, 24-bit Sensor data, Digital Pressure Counts,\
Percentage of full scale pressure,Pressure Output, Temperature\n");
  Serial.println(printBuffer);
  SPI.begin();
  pinMode(10, OUTPUT); // pin 10 as SS
  digitalWrite(10, HIGH); // set SS High
}
void loop() {
  delay(1);
  while (1) {
    uint8_t data[7] = {0xFA, 0x00, 0x00, 0x00, 0x00, 0x00, 0x00}; // holds output data
    uint8_t cmd[3] = {0xAA, 0x00, 0x00}; // command to be sent
    SPI.beginTransaction(SPISettings(200000, MSBFIRST, SPI_MODE0)); //SPI at 200kHz
    digitalWrite(10, LOW); // set SS Low
    SPI.transfer(cmd, 3); // send Read Command
    digitalWrite(10, HIGH); // set SS High
    delay(10); // wait for conversion
    digitalWrite(10, LOW);
    SPI.transfer(data, 7);
    digitalWrite(10, HIGH);
    SPI.endTransaction();
    press_counts = data[3] + data[2] * 256 + data[1] * 65536; // calculate digital pressure counts
    temp_counts = data[6] + data[5] * 256 + data[4] * 65536; // calculate digital temperature counts
    temperature = (temp_counts * 200 / 16777215) - 50; // calculate temperature in deg c
    percentage = (press_counts / 16777215) * 100; // calculate pressure as percentage of full scale
    //calculation of pressure value according to equation 2 of datasheet
    pressure = ((press_counts - outputmin) * (pmax - pmin)) / (outputmax - outputmin) + pmin;
    dtostrf(press_counts, 4, 1, cBuff);
    dtostrf(percentage, 4, 3, percBuff);
    dtostrf(pressure, 4, 3, pBuff);
    dtostrf(temperature, 4, 3, tBuff);
    /*
     The below code prints the raw data as well as the processed data
     Data format : Status Register, 24-bit Sensor Data, Digital Counts, percentage of full scale
     pressure, pressure output,
     temperature
    */
    sprintf(printBuffer, "%x\t%x\t%x\t%x\t%s\t%s\t%s\t%s\n", data[0], data[1], data[2], data[3],
      cBuff, percBuff, pBuff, tBuff);
    Serial.print(printBuffer);
    delay(10);
  }
}
```

ABP2 SERIES BASIC BOARD MOUNT PRESSURE SENSORS

8.0 ABP2 SERIES CALCULATIONS

8.1 DIGITAL OUTPUT VERSIONS

8.1.1 Pressure Output

The ABP2 Series sensor pressure output may be expressed by the transfer function of the device as shown in Equation 1:

Equation 1: Pressure Sensor Transfer Function

$$\text{Output} = \frac{\text{Output}_{\text{max.}} - \text{Output}_{\text{min.}}}{P_{\text{max.}} - P_{\text{min.}}} * (\text{Pressure} - P_{\text{min.}}) + \text{Output}_{\text{min.}}$$

Rearranging this equation to solve for Pressure provides Equation 2:

Equation 2: Pressure Output Function

$$\text{Pressure} = \frac{(\text{Output} - \text{Output}_{\text{min.}}) * (P_{\text{max.}} - P_{\text{min.}})}{\text{Output}_{\text{max.}} - \text{Output}_{\text{min.}}} + P_{\text{min.}}$$

Where:

Output_{max.} = output at maximum pressure [counts]

Output_{min.} = output at minimum pressure [counts]

P_{max.} = maximum value of pressure range [bar, psi, kPa, etc.]

P_{min.} = minimum value of pressure range [bar, psi, kPa, etc.]

Pressure = pressure reading [bar, psi, kPa, etc.]

Output = digital pressure reading [counts]

Example: Calculate the pressure for a -1 psi to 1 psi gage sensor with a 10 to 90 calibration, and a pressure output of 14260634 (decimal) counts:

Output_{max.} = 15099494 counts (90 of 2²⁴ counts or 0xE66666)

Output_{min.} = 1677722 counts (10 of 2²⁴ counts or 0x19999A)

P_{max.} = 1 psi

P_{min.} = -1 psi

Pressure = calculated pressure in psi

Output = 14260634 counts

$$\text{Pressure} = \left(\frac{(2.805 - 0.33 * (1 - (-1)))}{2.97 - 0.33} \right) + (-1)$$

$$\text{Pressure} = \left(\frac{25165824}{13421772} \right) + (-1)$$

Pressure = 0.875 psi

ABP2 SERIES BASIC BOARD MOUNT PRESSURE SENSORS

8.12 Temperature Output

The ABP2 Series sensor temperature output may be expressed by the transfer function of the device as shown in Equation 3:

Equation 3: Temperature Output Transfer Function

$$\text{Temperature} = \frac{T_{\text{out}} * (T_{\text{max.}} - T_{\text{min.}})}{(2^{(24)} - 1)} + T_{\text{min.}}$$

Where:

Temperature = calculated temperature output in °C

T_{out} = digital temperature output in counts (decimal)

$T_{\text{max.}}$ = 150°C

$T_{\text{min.}}$ = -50°C

Example: Calculate the temperature for a temperature output of 6291456 (decimal) counts.

$$\text{Temperature} = \frac{T_{\text{out}} * (150 - (-50))}{(2^{(24)} - 1)} + T_{\text{min.}}$$

$$\text{Temperature} = \frac{6291456 * 200}{16777215} - 50$$

$$\text{Temperature} = 25^{\circ}\text{C}$$

ABP2 SERIES BASIC BOARD MOUNT PRESSURE SENSORS

8.2 ANALOG OUTPUT VERSIONS

The ABP2 Series sensor temperature output may be expressed by the transfer function of the device as shown in Equation 1:

Equation 1: Pressure Output Transfer Function

$$\text{Output} = \frac{\text{Output}_{\text{max.}} - \text{Output}_{\text{min.}}}{P_{\text{max.}} - P_{\text{min.}}} * (\text{Pressure} - P_{\text{min.}}) + \text{Output}_{\text{min.}}$$

$$\text{Pressure} = \frac{(\text{Output} - \text{Output}_{\text{min.}}) * (P_{\text{max.}} - P_{\text{min.}})}{\text{Output}_{\text{max.}} - \text{Output}_{\text{min.}}} + P_{\text{min.}}$$

Where:

Output_{max.} = output at maximum pressure [Vdc]

Output_{min.} = output at minimum pressure [Vdc]

P_{max.} = maximum value of pressure range [bar, psi, kPa, etc.]

P_{min.} = minimum value of pressure range [bar, psi, kPa, etc.]

Pressure = pressure reading [bar, psi, kPa, etc.]

Output = digital pressure reading [Vdc]

Example: Calculate the pressure for a -1 psi to 1 psi gage sensor with a 10% to 90% calibration, and a pressure output of 2.805 Vdc at 3.3 Vdc supply voltage:

Output_{max.} = 2.97 Vdc (90% of V_{supply})

Output_{min.} = 0.33 Vdc (10% of V_{supply})

P_{max.} = 1 psi

P_{min.} = -1 psi

Pressure = pressure in psi

Output = 2.805 Vdc

$$\text{Pressure} = \left(\frac{(2.805 - 0.33) * (1 - (-1))}{2.97 - 0.33} \right) + (-1)$$

$$\text{Pressure} = \left(\frac{4.95}{2.64} \right) - 1$$

Pressure = 0.875 psi

ABP2 SERIES BASIC BOARD MOUNT PRESSURE SENSORS

9.0 RECOMMENDED PNEUMATIC SENSOR CONNECTIONS

9.1 TUBING

Tubing is a common method of pneumatically connecting to the sensors and needs to be matched to the sensor’s application to provide the required operating temperature range and working pressure. Depending on the working pressure range and operating temperature, the corresponding type of tubing can be selected (i.e., Superthane®, silicone, and vinyl). Silicone tubing, for instance, tends to be the easiest to which to connect; however, its working pressure is not as high as that of the other materials.

The lower the shore rating for the tubing, the easier it is to insert the tubing onto the sensor’s pressure port; however, the lower shore rated tubing also has lower working pressures. For working pressures of 20 psi and below, silicone or vinyl tubing tends to be used. For pressures above 20 psi, Superthane® or low-density polyethylene tubing may be considered. Table 28 shows recommended tubing for use with Honeywell’s Basic Board Mount Pressure Sensors.

Generally, when the working pressure is 15 psi or less, clamps are typically not required. However, because each application is different, the end use must be taken into account before determining whether clamps are necessary to ensure that the tubing remains in place and doesn’t leak. Considerations include vibration, pressure spikes, and the type of tubing being used. A common clamping method is to use a plastic cable tie, available in a variety of sizes and found in most hardware stores. They are relatively easy to install and stay in place over time.

NOTICE

Instead of using a clamp, a small drop of epoxy may be applied to either pressure port prior to the tubing being placed onto the port or applied at the end of the tubing once the tubing is in place. This method holds the tubing in place and can further act as a sealing agent to help ensure a leak-tight connection between the pressure port and the tubing. A room temperature sealant is generally used for this purpose. Ensure that the epoxy doesn’t block the hole in the port as it needs to remain open.

NOTICE

To apply a more rigid tubing-to-port connection, a low-power heat gun may be used to slightly heat the tubing. Once cooled, the tubing tends to grip the pressure port better.

TABLE 28. RECOMMENDED TUBING

| PRESSURE PORT | MANUFACTURER | TYPE | PART NUMBER | ID | OD | PRESSURE AT 25°C (PSI) |
|---------------|-------------------|---------------------------|-------------|----------|----------|------------------------|
| AN | Frelin-Wade | Fre-Thane® (polyurethane) | 1A-156-11 | 0.093 in | 0.156 in | 210 |
| AN | Frelin-Wade | nylon | 1A-200-01 | 0.093 in | 0.125 in | 270 |
| AN | NewAge Industries | PVC | 1100225 | 0.094 in | 0.156 in | 42 |
| AN | NewAge Industries | silicone | 2800315 | 0.094 in | 0.156 in | 20 |
| AN | McMaster | silicone | 5041K512 | 2,0 mm | 6,0 mm | 60 |
| AN | McMaster | silicone | 5041K601 | 2,0 mm | 6,0 mm | 115 |
| RN, RR | Frelin-Wade | Fre-Thane | 95a-157 | 0.066 in | 0.125 in | 225 |
| RN, RR | NewAge Industries | Superthane® (ether) | 2110535 | 0.066 in | 0.125 in | 135 |
| RN | NewAge Industries | silicone | 2800161 | 0.063 in | 0,188 in | 20 |
| RN, RR | Du-Bro | silicone | 196 1/16 ID | 0.063 in | 0.125 in | 20 |
| RN, RR | US Plastics | Excelthane polyurethane | 77901710 | 0.063 in | 0.125 in | 70 |
| RN, RR | McMaster | silicone | 5041K603 | 1,0 mm | 3.00 in | 15 |
| DA | McMaster | silicone | 5041K512 | 2,0 mm | 6,0 mm | 60 |

ABP2 SERIES BASIC BOARD MOUNT PRESSURE SENSORS

9.2 O-RING MANIFOLD DESIGNS

O-rings may also be used to connect pneumatically to the sensor. Most O-ring manufacturers recommend a compression of 20% to 25% to provide the proper O-ring compression over the temperature range. Silicone or fluorosilicone O-rings are commonly used as they tend to take less of a set over temperature versus other O-ring materials. System operating temperatures and sealant media compatibility are the two most important parameters which must be considered when selecting an O-ring base polymer. See Figures 19 and 20, and Table 29 for more information.

FIGURE 19. GUIDELINES FOR O-RING MANIFOLD DESIGNS¹

NN Pressure Port



VN Pressure Port²

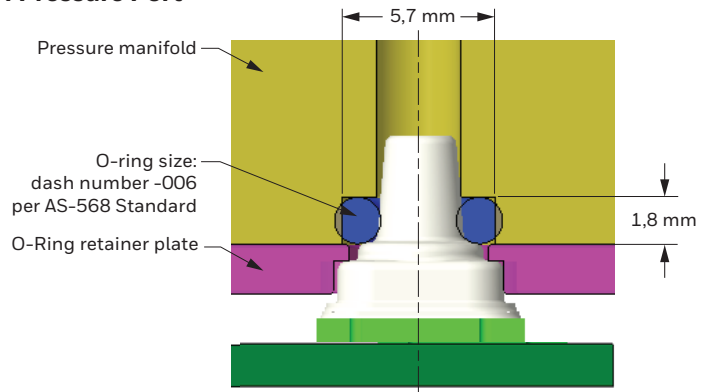

AN Pressure Port



SN Pressure Port²



¹The recommended design has been validated for operating conditions ranging from -40°C to 110°C and up to 16 bar gage pressure.

²For more demanding applications, a second O-ring can be used with a gland height of 3,6 mm (VN pressure port) and 4,55 mm (SN pressure port).

FIGURE 20. FORCE VS % OF O-RING COMPRESSION



NOTICE

It is the buyer's sole responsibility to determine the suitability of the product in the application.

ABP2 SERIES BASIC BOARD MOUNT PRESSURE SENSORS

TABLE 29. RECOMMENDED O-RINGS

| PRESSURE PORT | O-RING SIZE AS-568 UNIFORM DASH NUMBERS | O-RING ID (MM) | O-RING C/S (MM) | MATERIAL | SUPPLIER | PART NUMBER | SHORE HARDNESS |
|---------------|---|----------------|-----------------|-----------------|----------|-------------|----------------|
| NN | -004 | 1,78 | 1,78 | fluoroelastomer | McMaster | 8333T114 | durometer 70A |
| NN | -004 | 1,78 | 1,78 | silicone | McMaster | 1283N14 | durometer 70A |
| AN | -004 | 1,78 | 1,78 | fluoroelastomer | McMaster | 8333T114 | durometer 70A |
| AN | -004 | 1,78 | 1,78 | silicone | McMaster | 1283N14 | durometer 70A |
| SN | -005 | 2,75 | 1,78 | fluoroelastomer | McMaster | 8333T115 | durometer 70A |
| SN | -005 | 2,75 | 1,78 | silicone | McMaster | 1283N15 | durometer 70A |
| VN | -006 | 2,90 | 1,78 | fluoroelastomer | McMaster | 8333T116 | durometer 70A |
| VN | -006 | 2,90 | 1,78 | silicone | McMaster | 1283N16 | durometer 70A |