

## 1.5A, 600V - 1000V Standard Bridge Rectifier

### FEATURES

- AEC-Q101 qualified available
- Glass passivated chip junction
- Ideal for automated placement
- Reliable low cost construction utilizing molded plastic technique
- High surge current capability
- Moisture sensitivity level: level 1, per J-STD-020
- RoHS Compliant
- Halogen-free according to IEC 61249-2-21

### APPLICATIONS

- Switching mode power supply (SMPS)
- Adapters
- Lighting application

### MECHANICAL DATA

- Case: ABS
- Molding compound meets UL 94V-0 flammability rating
- Terminal: Matte tin plated leads, solderable per J-STD-002
- Meet JESD 201 class 2 whisker test
- Polarity: As marked
- Weight: 0.096g (approximately)

KEY PARAMETERS		
PARAMETER	VALUE	UNIT
$I_F$	1.5	A
$V_{RRM}$	600 - 1000	V
$I_{FSM}$	40	A
$T_{J\ MAX}$	150	°C
Package	ABS	
Configuration	Quad	

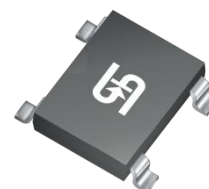

ABS

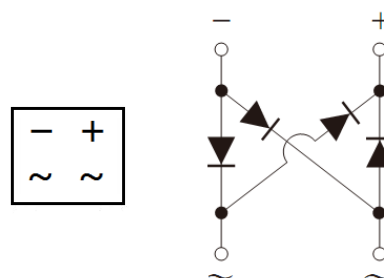

ABSOLUTE MAXIMUM RATINGS ( $T_A = 25^\circ\text{C}$ unless otherwise noted)				
PARAMETER	SYMBOL	ABS15J	ABS15M	UNIT
Marking code on the device		ABS15J	ABS15M	
Repetitive peak reverse voltage	$V_{RRM}$	600	1000	V
Reverse voltage, total rms value	$V_{R(RMS)}$	420	700	V
Forward current	On glass-epoxy	$I_F$	1.5	A
	On aluminum substrate		2.0	A
Surge peak forward current single half sinewave superimposed on rated load	$t = 8.3\text{ms}$	$I_{FSM}$	40	A
	$t = 1.0\text{ms}$		100	A
Rating for fusing ( $t < 8.3\text{ms}$ )	$I^2t$	6.64		$\text{A}^2\text{s}$
Junction temperature	$T_J$	- 55 to +150		°C
Storage temperature	$T_{STG}$	- 55 to +150		°C

**THERMAL PERFORMANCE**

PARAMETER	SYMBOL	TYP	UNIT
Junction-to-lead thermal resistance	$R_{\theta JL}$	25	°C/W
Junction-to-ambient thermal resistance	$R_{\theta JA}$	80	°C/W

**ELECTRICAL SPECIFICATIONS** ( $T_A = 25^\circ\text{C}$  unless otherwise noted)

PARAMETER	CONDITIONS	SYMBOL	TYP	MAX	UNIT
Forward voltage per diode <sup>(1)</sup>	$I_F = 0.5\text{A}, T_J = 25^\circ\text{C}$	$V_F$	0.88	-	V
	$I_F = 1.5\text{A}, T_J = 25^\circ\text{C}$		0.97	1.00	V
Reverse current @ rated $V_R$ per diode <sup>(2)</sup>	$T_J = 25^\circ\text{C}$	$I_R$	-	5	$\mu\text{A}$
	$T_J = 125^\circ\text{C}$		-	150	$\mu\text{A}$

**Notes:**

1. Pulse test with  $PW = 0.3\text{ms}$
2. Pulse test with  $PW = 30\text{ms}$

**ORDERING INFORMATION**

ORDERING CODE <sup>(1)(2)</sup>	PACKAGE	PACKING
ABS15x	ABS	5,000 / Tape & Reel
ABS15xH	ABS	5,000 / Tape & Reel

**Notes:**

1. "x" defines voltage from 600V(ABS15J) to 1000V(ABS15M)
2. "H" means AEC-Q101 qualified

**CHARACTERISTICS CURVES**

( $T_A = 25^\circ\text{C}$  unless otherwise noted)

**Fig.1 Forward Current Derating Curve**

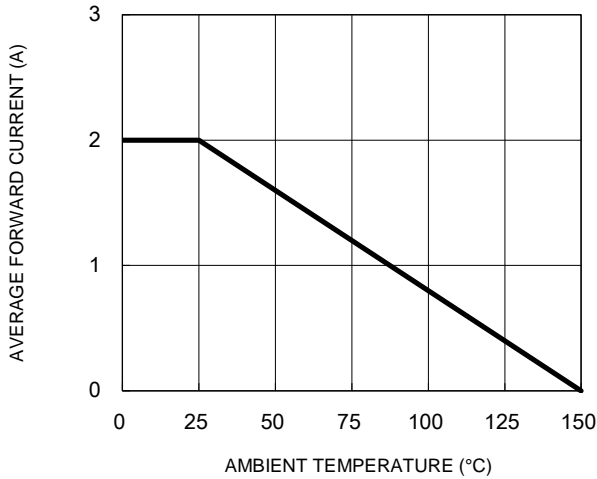

**Fig.2 Typical Junction Capacitance**

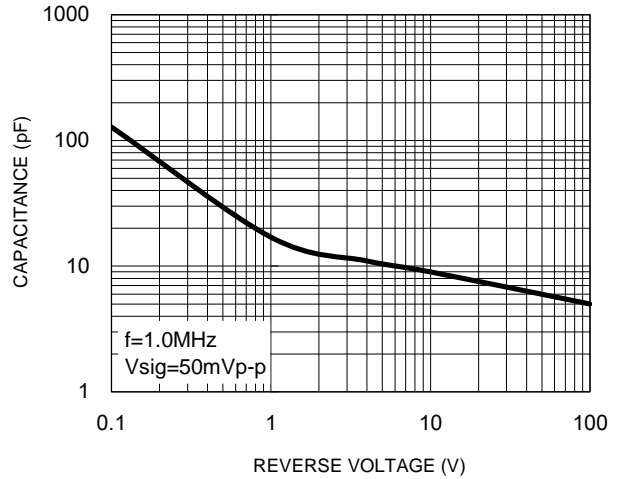

**Fig.3 Typical Reverse Characteristics**

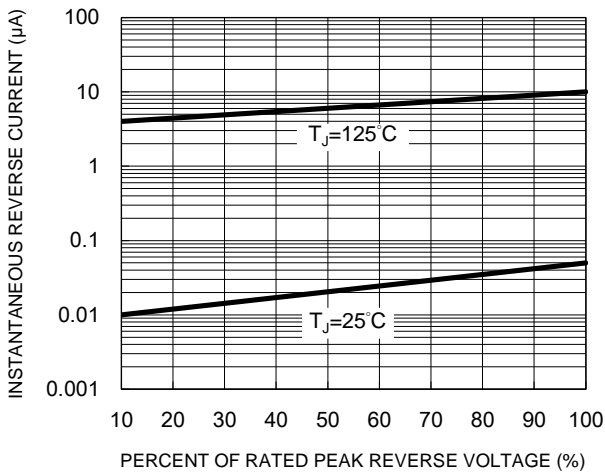

**Fig.4 Typical Forward Characteristics**

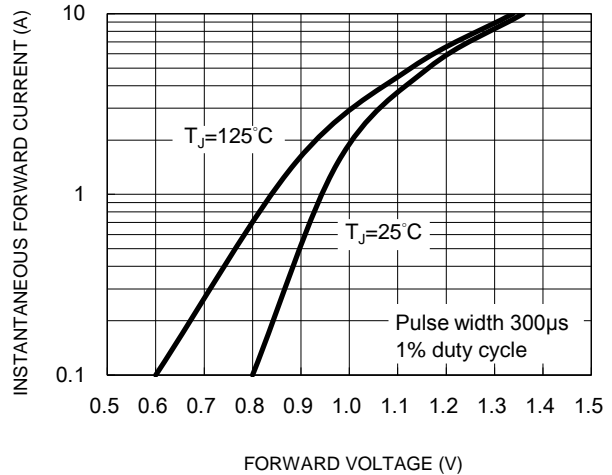

**Fig.5 Maximum Non-Repetitive Forward Surge Current**

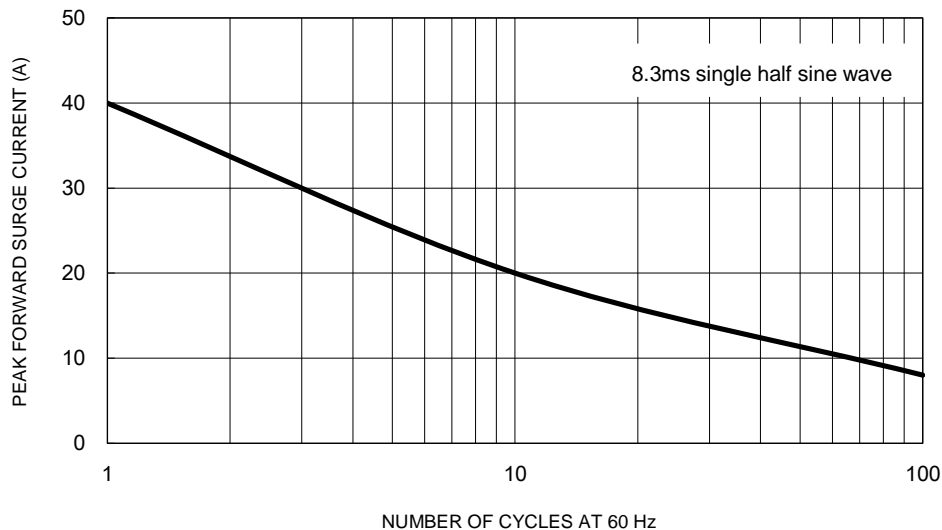

**PACKAGE OUTLINE DIMENSIONS**

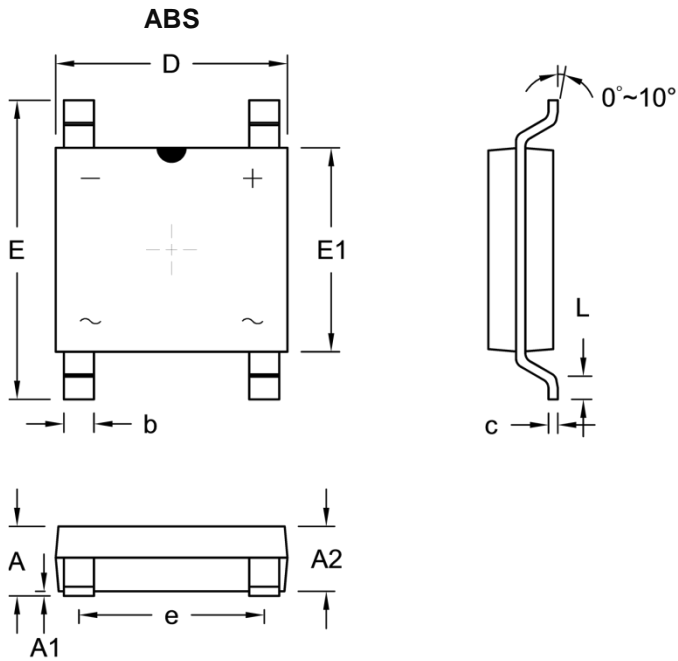

DIM.	Unit (mm)		Unit (inch)	
	Min.	Max.	Min.	Max.
A	1.40	1.60	0.055	0.063
A1	0.05	0.15	0.002	0.006
A2	1.35	1.45	0.053	0.057
b	0.60	0.70	0.024	0.028
c	0.15	0.25	0.006	0.010
D	4.90	5.10	0.193	0.201
E	6.25	6.65	0.246	0.262
E1	4.30	4.50	0.169	0.177
e	3.90	4.10	0.154	0.161
L	0.30	0.70	0.012	0.028

**SUGGESTED PAD LAYOUT**

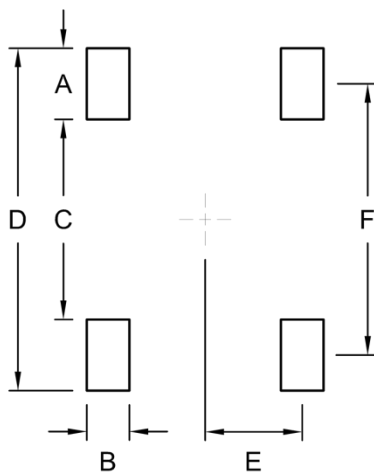

Symbol	Unit (mm)	Unit (inch)
A	1.50	0.059
B	0.90	0.035
C	4.22	0.166
D	7.22	0.284
E	2.05	0.081
F	5.72	0.225

**MARKING DIAGRAM**

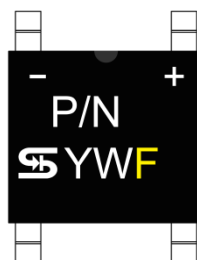

P/N = Marking Code  
 YW = Date Code  
 F = Factory Code