

1.5A, 600V Low V_F Standard Bridge Rectifier

FEATURES

- Ideal for automated placement
- Reliable low cost construction utilizing molded plastic technique
- High surge current capability
- Moisture sensitivity level: level 1, per J-STD-020
- RoHS Compliant
- Halogen-free according to IEC 61249-2-21

APPLICATIONS

- Switching mode power supply (SMPS)
- Adapters
- Lighting application

MECHANICAL DATA

- Case: ABS
- Molding compound meets UL 94V-0 flammability rating
- Terminal: Matte tin plated leads, solderable per J-STD-002
- Meet JESD 201 class 1A whisker test
- Polarity: As marked
- Weight: 0.096g (approximately)

| KEY PARAMETERS | | |
|----------------|-------|------|
| PARAMETER | VALUE | UNIT |
| I_F | 1.5 | A |
| V_{RRM} | 600 | V |
| I_{FSM} | 60 | A |
| $T_{J\ MAX}$ | 150 | °C |
| Package | ABS | |
| Configuration | Quad | |

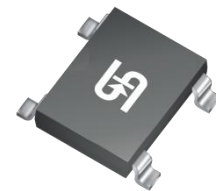

ABS

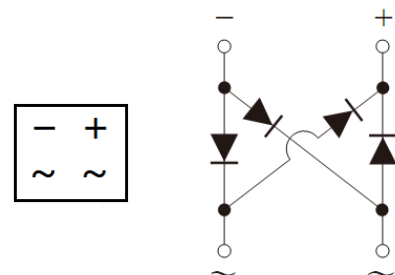

| ABSOLUTE MAXIMUM RATINGS ($T_A = 25^\circ\text{C}$ unless otherwise noted) | | | |
|--|--------------|--------------|----------------------|
| PARAMETER | SYMBOL | ABS15LJ | UNIT |
| Marking code on the device | | ABS15LJ | |
| Repetitive peak reverse voltage | V_{RRM} | 600 | V |
| Reverse voltage, total rms value | $V_{R(RMS)}$ | 420 | V |
| Forward current | I_F | 1.5 | A |
| Peak forward surge current, 8.3ms single half sine-wave superimposed on rated load | I_{FSM} | 60 | A |
| Rating for fusing ($t < 8.3\text{ms}$) | I^2t | 14.94 | A^2s |
| Junction temperature | T_J | - 55 to +150 | °C |
| Storage temperature | T_{STG} | - 55 to +150 | °C |

| THERMAL PERFORMANCE | | | |
|--|-----------------|------------|-------------|
| PARAMETER | SYMBOL | TYP | UNIT |
| Junction-to-lead thermal resistance | $R_{\theta JL}$ | 25 | °C/W |
| Junction-to-ambient thermal resistance | $R_{\theta JA}$ | 80 | °C/W |

| ELECTRICAL SPECIFICATIONS ($T_A = 25^\circ\text{C}$ unless otherwise noted) | | | | | |
|---|---|---------------|------------|------------|---------------|
| PARAMETER | CONDITIONS | SYMBOL | TYP | MAX | UNIT |
| Forward voltage per diode ⁽¹⁾ | $I_F = 0.5\text{A}, T_J = 25^\circ\text{C}$ | V_F | 0.85 | - | V |
| | $I_F = 1.5\text{A}, T_J = 25^\circ\text{C}$ | | 0.90 | 0.95 | V |
| Reverse current @ rated V_R per diode ⁽²⁾ | $T_J = 25^\circ\text{C}$ | I_R | - | 5 | μA |
| | $T_J = 125^\circ\text{C}$ | | - | 150 | μA |

Notes:

1. Pulse test with PW = 0.3ms
2. Pulse test with PW = 30ms

| ORDERING INFORMATION | | |
|-----------------------------|----------------|---------------------|
| ORDERING CODE | PACKAGE | PACKING |
| ABS15LJ | ABS | 5,000 / Tape & Reel |

CHARACTERISTICS CURVES

($T_A = 25^\circ\text{C}$ unless otherwise noted)

Fig.1 Forward Current Derating Curve

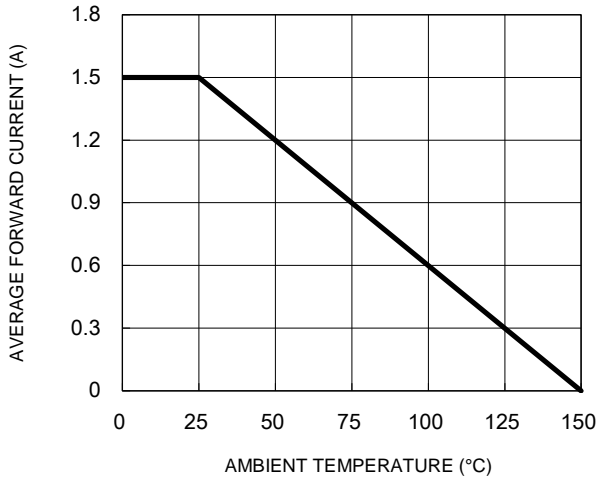

Fig.2 Typical Junction Capacitance

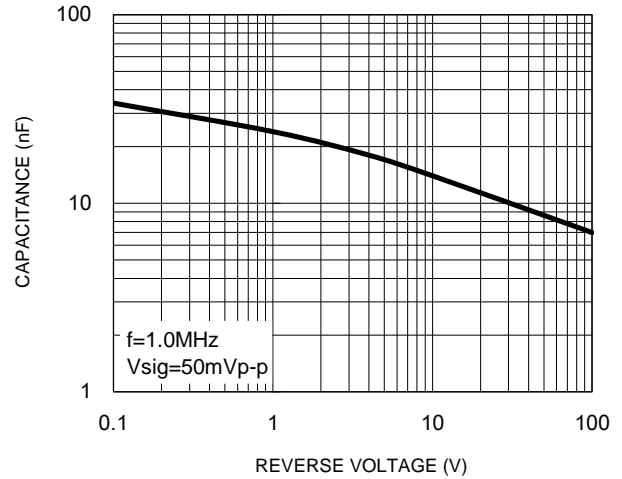

Fig.3 Typical Reverse Characteristics

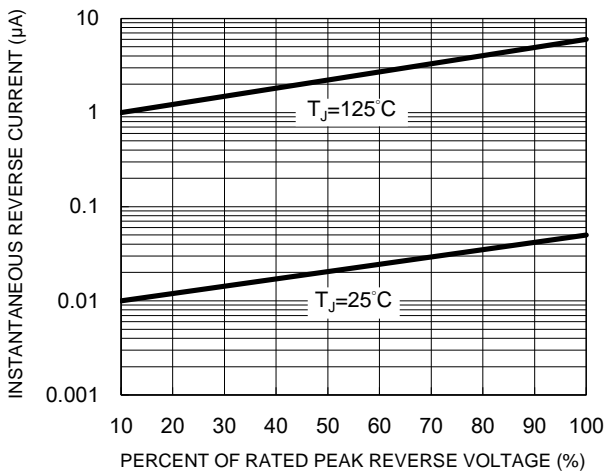

Fig.4 Typical Forward Characteristics

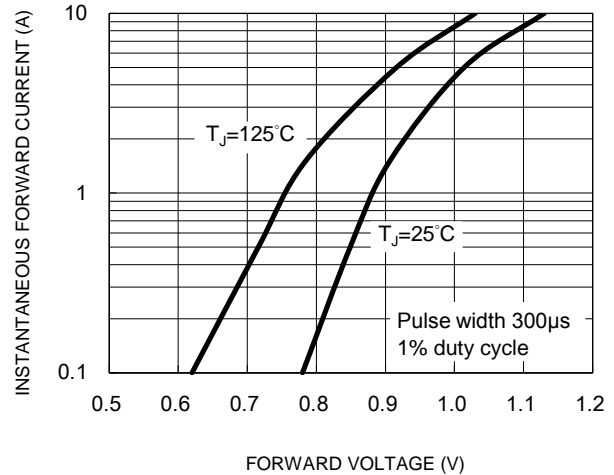
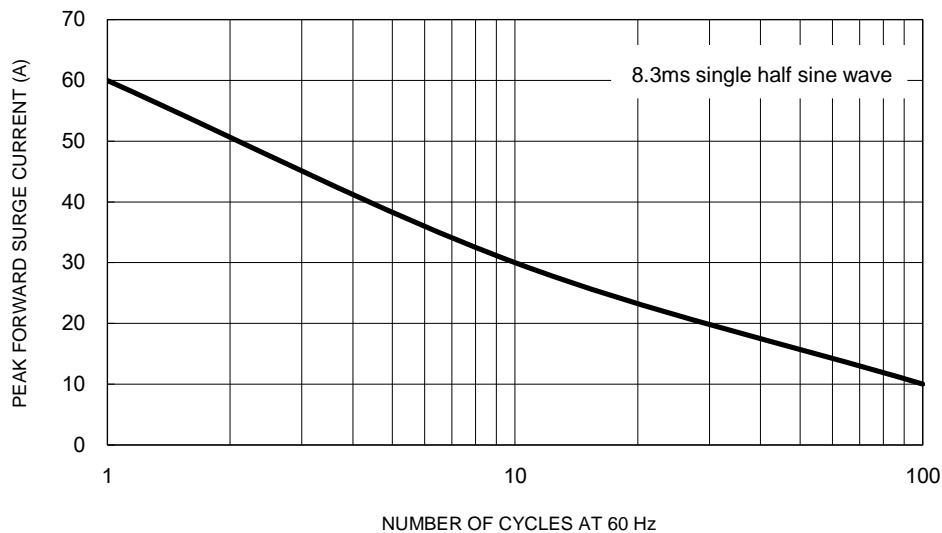
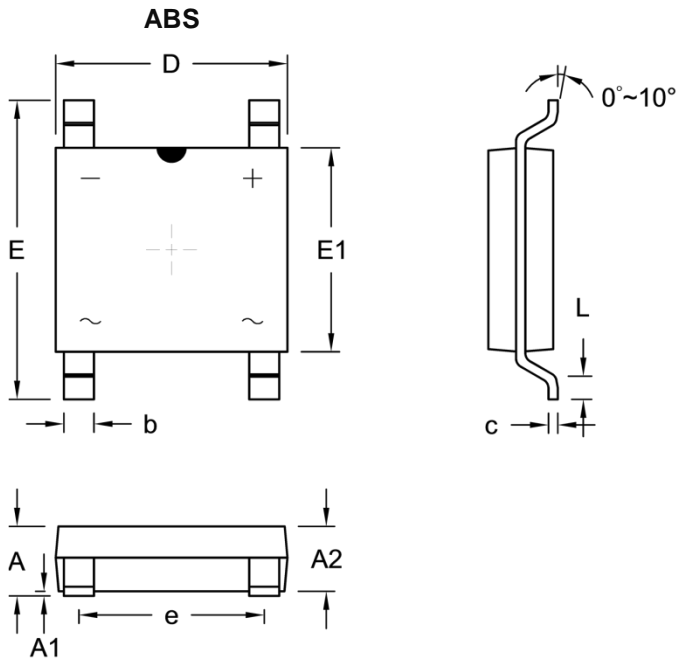

Fig.5 Maximum Non-Repetitive Forward Surge Current



PACKAGE OUTLINE DIMENSIONS



| DIM. | Unit (mm) | | Unit (inch) | |
|------|-----------|------|-------------|-------|
| | Min. | Max. | Min. | Max. |
| A | 1.40 | 1.60 | 0.055 | 0.063 |
| A1 | 0.05 | 0.15 | 0.002 | 0.006 |
| A2 | 1.35 | 1.45 | 0.053 | 0.057 |
| b | 0.60 | 0.70 | 0.024 | 0.028 |
| c | 0.15 | 0.25 | 0.006 | 0.010 |
| D | 4.90 | 5.10 | 0.193 | 0.201 |
| E | 6.25 | 6.65 | 0.246 | 0.262 |
| E1 | 4.30 | 4.50 | 0.169 | 0.177 |
| e | 3.90 | 4.10 | 0.154 | 0.161 |
| L | 0.30 | 0.70 | 0.012 | 0.028 |

SUGGESTED PAD LAYOUT

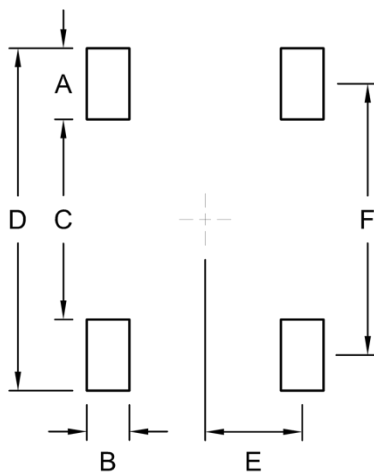

| Symbol | Unit (mm) | Unit (inch) |
|--------|-----------|-------------|
| A | 1.50 | 0.059 |
| B | 0.90 | 0.035 |
| C | 4.22 | 0.166 |
| D | 7.22 | 0.284 |
| E | 2.05 | 0.081 |
| F | 5.72 | 0.225 |

MARKING DIAGRAM

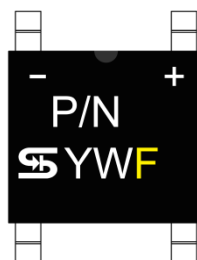

P/N = Marking Code
 YW = Date Code
 F = Factory Code