

## ABS210-HF

Reverse Voltage: 1000 Volts

Forward Current: 2.0 A

RoHS Device

Halogen Free

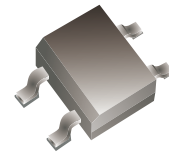

### Features

- High surge current capability.
- Designed for surface mount application.

### Mechanical data

- Case: ABS/LBF, molded plastic.
- Terminals: Solderable per MIL-STD-750, method 2026.

### Circuit Diagram

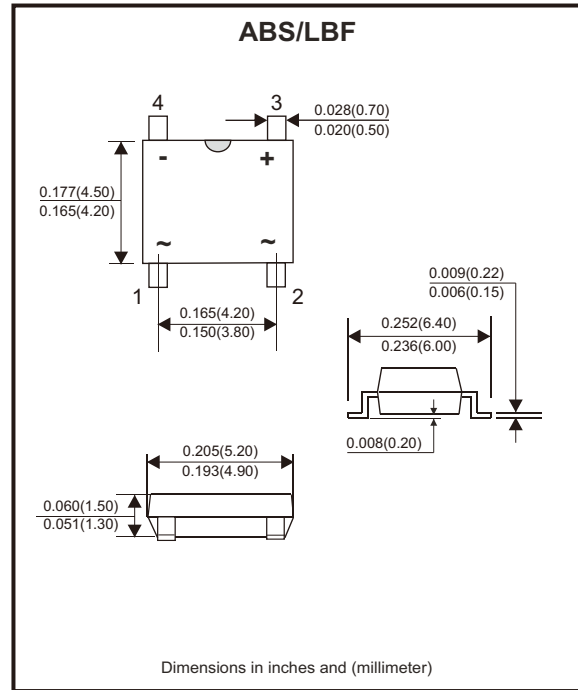
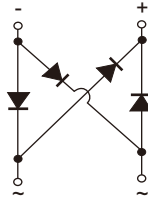

### Maximum Rating and Electrical Characteristics

Rating at  $T_A=25^{\circ}\text{C}$ , unless otherwise noted.  
 Single phase, half wave, 60Hz, resistive or inductive load.  
 For capacitive load, derate current by 20%.

Parameter	Symbol	ABS210-HF	Unit
Maximum repetitive peak reverse voltage	$V_{RRM}$	1000	V
Maximum RMS voltage	$V_{RMS}$	700	V
Maximum DC blocking voltage	$V_{DC}$	1000	V
Average rectified output current at $T_c=115^{\circ}\text{C}$	$I_o$	2.0	A
Peak forward surge current, 8.3ms single half sine-wave, superimposed on rated load (JEDEC Method)	$I_{FSM}$	55	A
Forward voltage per element @ $I_F=2.0\text{A}$	$V_F$	1.0	V
Maximum DC reverse current at rated DC blocking voltage @ $T_J=25^{\circ}\text{C}$ @ $T_J=125^{\circ}\text{C}$	$I_R$	5.0 100	$\mu\text{A}$
Typical junction capacitance (Note 1)	$C_j$	25	pF
Typical thermal resistance (Note 2)	$R_{\theta JA}$ $R_{\theta JC}$	60 16	$^{\circ}\text{C}/\text{W}$
Operating and storage temperature range	$T_J, T_{STG}$	-55 to +150	$^{\circ}\text{C}$

Notes: 1. Mounted at 1MHz and applied reverse voltage of 4V D.C.  
 2. Mounted on glass epoxy PC board with 4 x 1.5" x 1.5" (3.81 x3.81 cm) copper pad.

Company reserves the right to improve product design , functions and reliability without notice.

REV:A

## Rating and Characteristic Curves (ABS210-HF)

Fig.1 - Average Rectified Output Current Derating Curve

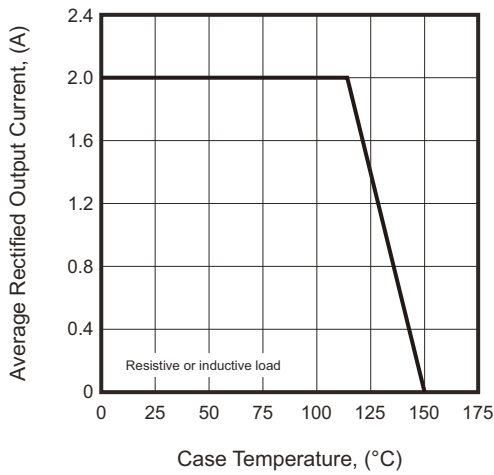

Fig.2 - Typical Reverse Characteristics

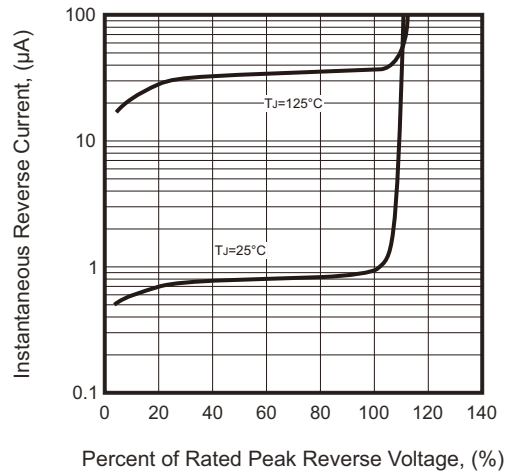

Fig.3 - Typical Instantaneous Forward Characteristics

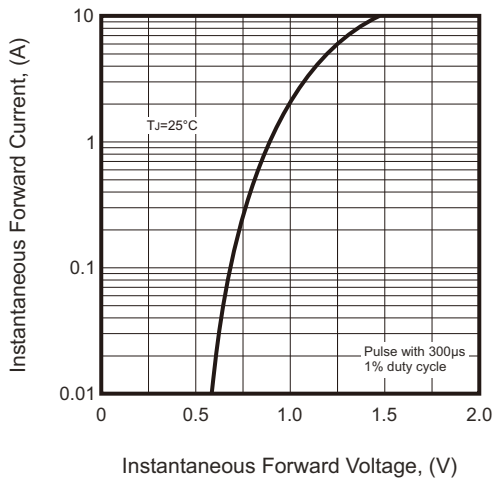

Fig.4 - Typical Junction Capacitance

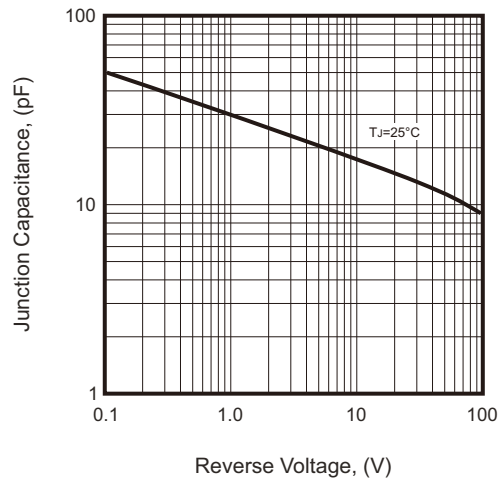
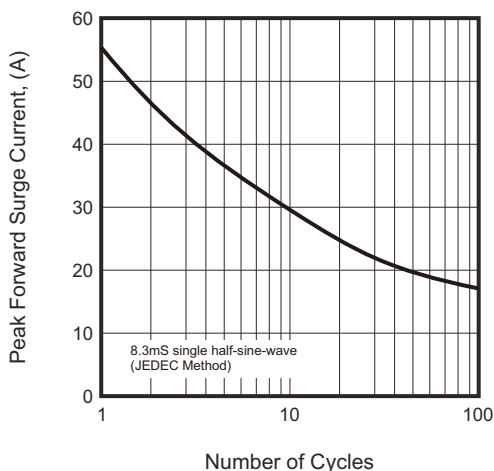

Fig.5 - Max. Non-Repetitive Peak Forward Surge Current



Company reserves the right to improve product design, functions and reliability without notice.

REV:A

## Reel Taping Specification

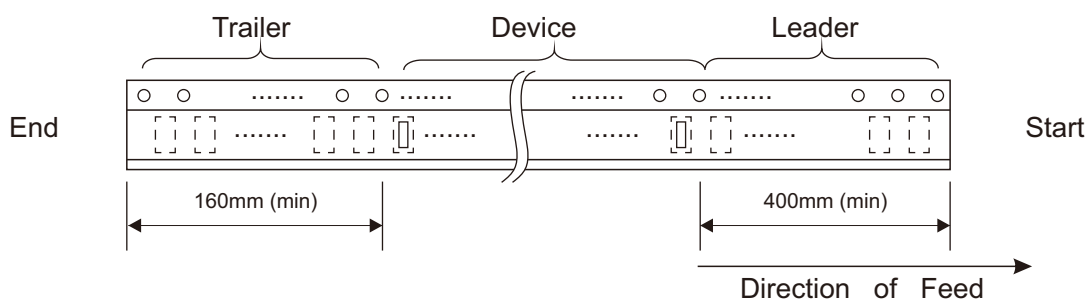
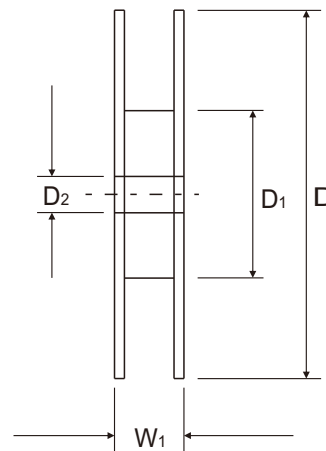
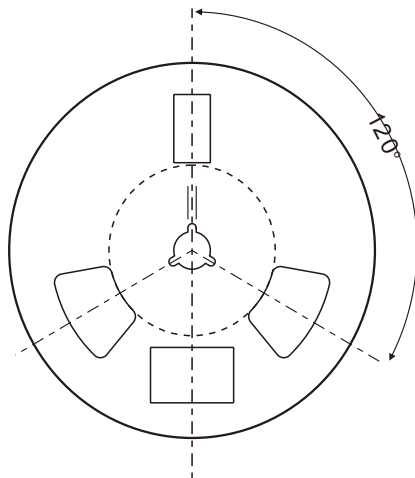
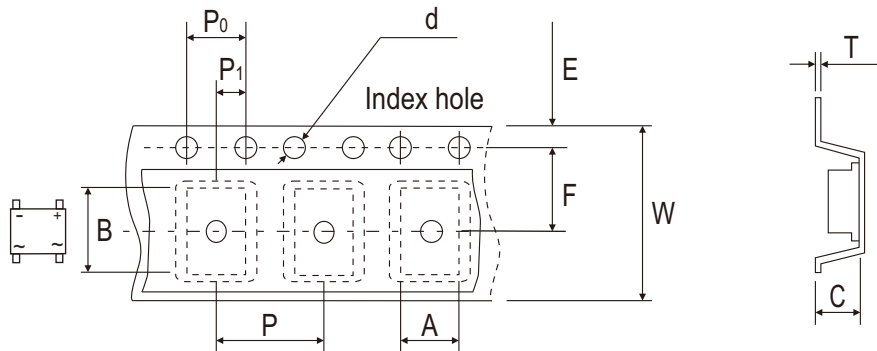

ABS/LBF	SYMBOL	A	B	C	d	D	D1	D2
	(mm)	5.31 ± 0.10	6.70 ± 0.10	1.59 ± 0.10	1.50 ± 0.10	330 ± 2.00	75 ± 1.00	13.00 ± 0.20
	(inch)	0.209 ± 0.004	0.264 ± 0.004	0.063 ± 0.004	0.059 ± 0.004	12.992 ± 0.079	2.953 ± 0.039	0.512 ± 0.008

ABS/LBF	SYMBOL	E	F	P	P0	P1	T	W	W1
	(mm)	1.75 ± 0.10	5.50 ± 0.05	8.00 ± 0.10	4.00 ± 0.10	2.00 ± 0.05	0.26 ± 0.05	12.00 ± 0.30	14.70 + 2.00 - 1.00
	(inch)	0.069 ± 0.004	0.217 ± 0.002	0.315 ± 0.004	0.157 ± 0.004	0.079 ± 0.002	0.010 ± 0.002	0.472 ± 0.012	0.579 + 0.079 - 0.039

Company reserves the right to improve product design, functions and reliability without notice.

REV:A