

## Automotive High-Speed, Low-Power Digital Optocoupler with R<sup>2</sup>Coupler® Isolation in a Stretched 12-Pin Surface Mount Plastic Package

### Data Sheet

#### Description

The ACFL-6211T and ACFL-6212T are automotive grade dual channel, bi-directional, high speed digital CMOS optocouplers. The stretched SO-12 stretched package outline is designed to be compatible with standard surface mount processes and occupies the same land area as their single channel equivalent, ACPL-K71T and ACPL-K72T, in stretched SO8 package.

This digital optocoupler uses an insulating layer between the light emitting diode and an integrated photo detector to provide electrical insulation between input and output. Each channel of the digital optocoupler has a CMOS detector IC with an integrated photodiode, a high speed trans-impedance amplifier, and a voltage comparator with an output driver. Each channel is also isolated from the other.

Broadcom R<sup>2</sup>Coupler technology provides reinforced insulation and reliability that delivers safe signal isolation critical in automotive and high temperature industrial applications.

#### Functional Diagram

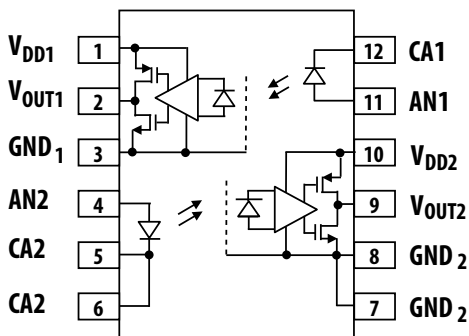

Note: The connection of a 1  $\mu$ F bypass capacitor between pins 1 and 3 and pins 10 and 7/8 (or 7 and 8) is recommended.

#### Truth Table

LED	OUTPUT
ON	LOW
OFF	HIGH

#### Features

- Qualified to AEC Q100 Grade 1 Test Guidelines
- Automotive Wide Temperature Range:  $-40^{\circ}\text{C}$  to  $+125^{\circ}\text{C}$
- 5V CMOS compatibility
- 40 kV/ $\mu\text{s}$  Common-Mode Rejection at  $V_{\text{CM}}=1000\text{V}$  (typ)
- Low Propagation Delay :
  - ACFL-6211T: 25 ns at  $I_{\text{F}} = 10 \text{ mA}$  (typ)
  - ACFL-6212T: 60 ns at  $I_{\text{F}} = 4 \text{ mA}$  (typ)
- Compact, Auto-Insertable Stretched SO12 Packages
- Worldwide Safety Approval:
  - UL 1577 recognized, 5 kV<sub>RMS</sub>/1 min.
  - CSA Approved
  - IEC/EN/DIN EN 60747-5-5

#### Features

- Automotive IPM Driver for DC-DC converters and motor inverters
- CANBus and SPI Communications Interface
- High Temperature Digital/Analog Signal Isolation
- Power Transistor Isolation

**CAUTION:** It is advised that normal static precautions be taken in handling and assembly of this component to prevent damage and/or degradation which may be induced by ESD. The components featured in this datasheet are not to be used in military or aerospace applications or environments.

## Pin Description

Pin No.	Pin Name	Description
1	V <sub>DD1</sub>	Primary Side Power Supply
2	V <sub>OUT1</sub>	Output 1
3	GND1	Primary Side Ground
4	AN2	Anode 2
5	CA2	Cathode 2
6	CA2	Cathode 2

Pin No.	Pin Name	Description
7	GND2	Secondary Side Ground
8	GND2	Secondary Side Ground
9	V <sub>OUT2</sub>	Output 2
10	V <sub>DD2</sub>	Secondary Side Power Supply
11	AN1	Anode 1
12	CA1	Cathode 1

## Ordering Information

Part Number	Option (RoHS Compliant)	Package	Surface Mount	Tape and Reel	UL 5000 V <sub>RMS</sub> / 1 Minute Rating	IEC/EN/DIN EN 60747-5-5	Quantity
ACFL-6211T	-000E	Stretched SO-12	X		X		80 per tube
	-060E		X		X	X	80 per tube
	-500E		X	X	X		1000 per reel
	-560E		X	X	X	X	1000 per reel
ACFL-6212T	-000E	Stretched SO-12	X		X		80 per tube
	-060E		X		X	X	80 per tube
	-500E		X	X	X		1000 per reel
	-560E		X	X	X	X	1000 per reel

To order, choose a part number from the part number column and combine with the desired option from the option column to form an order entry.

Example:

ACFL-6212T-560E to order product of SSO-12 Surface Mount package in Tape and Reel packaging with IEC/EN/DIN EN 60747-5-5 Safety Approval in RoHS compliant.

Option datasheets are available. Contact your Broadcom sales representative or authorized distributor for information.

# Package Outline Drawing

## 12-Lead Surface Mount

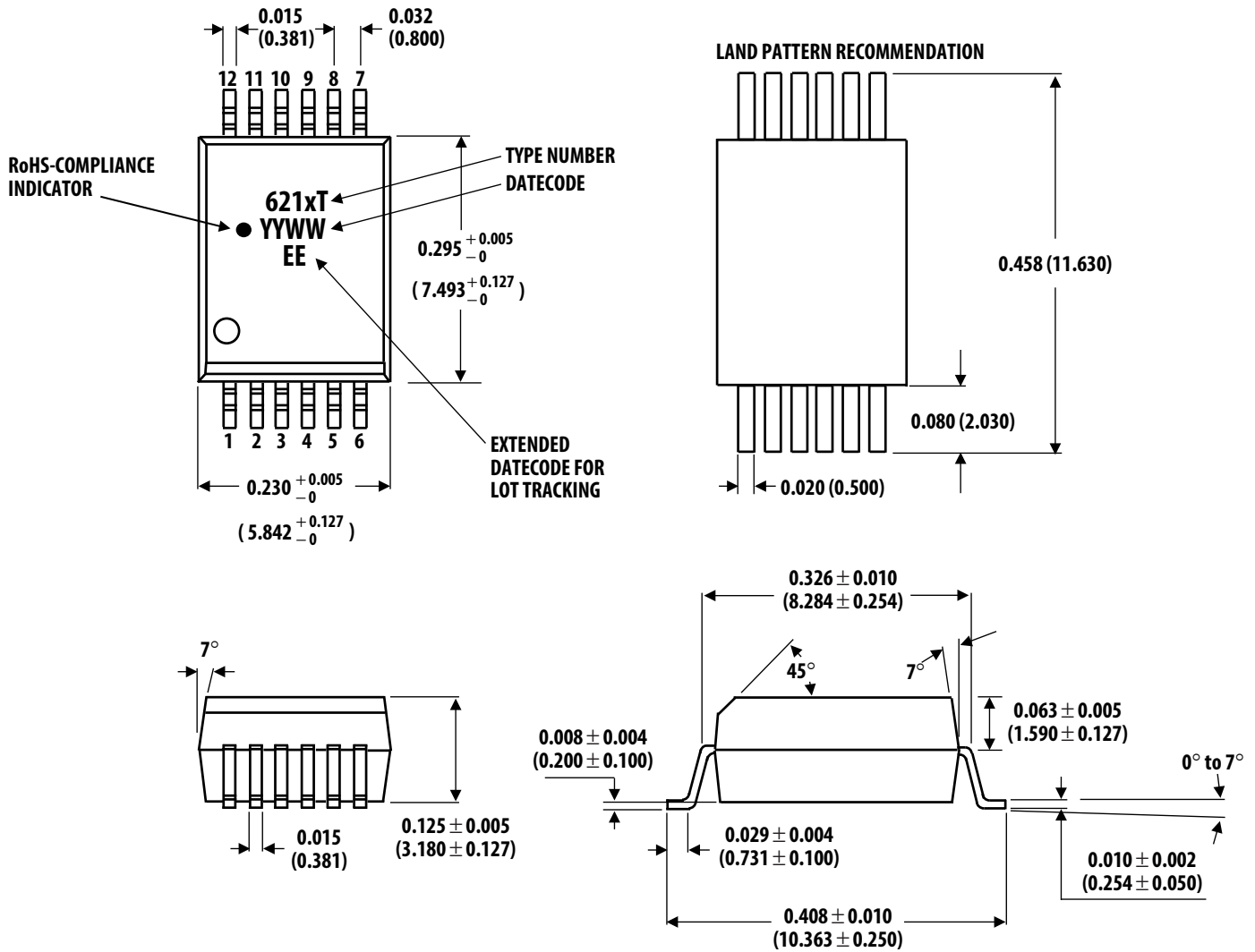

Dimensions in inches (millimeters)

Lead coplanarity = 0.004 inches (0.1 mm)

### Recommended Pb-Free IR Profile

Recommended reflow condition as per JEDEC Standard, J-STD-020 (latest revision).

Note: Non-halide flux should be used

## Regulatory Information

The ACFL-6211T and ACFL-6212T are approved by the following organizations:

<b>UL</b>	UL 1577, component recognition program up to $V_{ISO} = 5 \text{ kV}_{RMS}$
<b>CSA</b>	Approved under CSA Component Acceptance Notice #5
<b>IEC/EN/DIN EN 60747-5-5</b>	Approved under IEC/EN/DIN EN 60747-5-5

## Insulation and Safety Related Specifications

Parameter	Symbol	ACFL-6211T/ ACFL-6212T	Unit	Conditions
Minimum External Air Gap (Clearance)	L(101)	8.3	mm	Measured from input terminals to output terminals, shortest distance through air.
Minimum External Tracking (Creepage)	L(102)	8.5	mm	Measured from input terminals to output terminals, shortest distance path along body.
Minimum Internal Plastic Gap (Internal Clearance)		0.08	mm	Through insulation distance conductor to conductor, usually the straight line distance thickness between the emitter and detector.
Tracking Resistance (Comparative Tracking Index)	CTI	175	V	DIN IEC 112/VDE 0303 Part 1
Isolation Group (DIN VDE0109)		IIIa		Material Group (DIN VDE 0109)

## IEC/EN/DIN EN 60747-5-5 Insulation Related Characteristic (Option 060E and 560E)

Description	Symbol	Characteristic	Unit
Installation classification per DIN VDE 0110/1.89, Table 1 for rated mains voltage $\leq 600V_{RMS}$ for rated mains voltage $< 1000V_{RMS}$		I-III I-III	
Climatic Classification		40/125/21	
Pollution Degree (DIN VDE 0110/1.89)		2	
Maximum Working Insulation Voltage	$V_{IORM}$	1140	$V_{PEAK}$
Input to Output Test Voltage, Method b $V_{IORM} \times 1.875 = V_{PR}$ , 100% Production Test with $t_m = 1 \text{ sec}$ , Partial Discharge $< 5 \text{ pC}$	$V_{PR}$	2137	$V_{PEAK}$
Input to Output Test Voltage, Method a $V_{IORM} \times 1.6 = V_{PR}$ , Type and sample test, $t_m = 10 \text{ sec}$ , Partial Discharge $< 5 \text{ pC}$	$V_{PR}$	1824	$V_{PEAK}$
Highest Allowable Overvoltage (Transient Overvoltage, $t_{ini} = 60 \text{ sec}$ )	$V_{IOTM}$	6000	$V_{PEAK}$
Safety Limiting Values (Maximum values allowed in the event of a failure)			
Case Temperature	$T_S$	175	$^{\circ}\text{C}$
Input Current	$I_{S,INPUT}$	230	mA
Output Power	$P_{S,OUTPUT}$	600	mW
Insulation Resistance at $T_S$ , $V_{IO} = 500V$	$R_S$	$10^9$	$\Omega$

## Absolute Maximum Ratings

Parameter	Symbol	Min.	Max.	Unit	Condition
Storage Temperature	$T_S$	-55	+150	°C	
Ambient Operating Temperature <sup>[1]</sup>	$T_A$	-40	+125	°C	
Junction Temperature	$T_J$		+150	°C	
Supply Voltages	$V_{DD}$	0	6.5	V	
Output Voltage	$V_O$	-0.5	$V_{DD} + 0.5$	V	
Average Forward Input Current	$I_F$		20.0	mA	
Peak Transient Input Current ( $I_F$ at 1 $\mu$ s pulse width, <10% duty cycle)	$I_{F(TRAN)}$		1 80	A mA	$\leq 1 \mu$ s Pulse Width, 300 pps $\leq 1 \mu$ s Pulse Width, <10% Duty Cycle
Reverse Input Voltage	$V_r$		5	V	
Input Power Dissipation	$P_I$		40	mW	
Average Output Current	$I_O$		10	mA	
Output Power Dissipation	$P_O$		30	mW	
Lead Solder Temperature	260°C for 10 sec., 1.6 mm below seating plane				
Solder Reflow Temperature Profile	See Solder Reflow Temperature Profile Section				

## Recommended Operating Conditions

Parameter	Symbol	Min.	Max.	Unit	Note
Supply Voltage	$V_{DD}$	3.0	5.5	V	
Operating Temperature	$T_A$	-40	+125	°C	
Forward Input Current	$I_{F(ON)}$	4.0	15	mA	
Forward Off State Voltage	$V_{F(OFF)}$		0.8	V	
Input Threshold Current	$I_{TH}$		3.5	mA	

## Electrical Specifications

Over recommended operating conditions. All typical specifications are at  $T_A = 25^\circ\text{C}$ ,  $V_{DD} = 5\text{V}$ .

Parameter	Symbol	Min.	Typ.	Max.	Unit	Test Conditions	Fig.
LED Forward Voltage	$V_F$	1.45	1.5	1.75	V	$I_F = 10 \text{ mA}$ , $T_A = 25^\circ\text{C}$	
		1.25	1.5	1.85	V	$I_F = 10 \text{ mA}$	
VF Temperature Coefficient			-1.5		mV/°C		
Input Threshold Current	$I_{TH}$		1.3	3.5	mA		2
Input Capacitance	$C_{IN}$		90		pF		
Input Reverse Breakdown Voltage	$BV_R$	5.0			V	$I_R = 10 \mu\text{A}$	
Logic High Output Voltage	$V_{OH}$	$V_{DD} - 0.6$			V	$I_{OH} = -3.2 \text{ mA}$	4
Logic Low Output Voltage	$V_{OL}$			0.6	V	$I_{OL} = 4 \text{ mA}$	3
Logic Low Output Supply Current (per channel)	$I_{DDL}$		0.9	1.5	mA		
Logic High Output Supply Current (per channel)	$I_{DDH}$		0.9	1.5	mA		

## ACFL-6211T High Speed Mode Switching Specifications

Over recommended operating conditions:  $T_A = -40^{\circ}\text{C}$  to  $+125^{\circ}\text{C}$ ,  $4.5\text{V} \leq V_{DD} \leq 5.5\text{V}$ . All typical specifications are at  $T_A = 25^{\circ}\text{C}$ ,  $V_{DD} = 5\text{V}$ .

Parameter	Symbol	Min.	Typ.	Max.	Unit	Test Conditions	Fig.	Note
Propagation Delay Time to Logic Low Output	$t_{PHL}$		25	35	ns	$V_{in} = 4.5\text{V}$ to $5.5\text{V}$ , $R_{in} = 390\Omega \pm 5\%$ , $C_{in} = 100\text{ pF}$ , $C_L = 15\text{ pF}$  Output low threshold = $0.8\text{V}$ Output high threshold = $80\%$ of $V_{DD}$	5, 9, 11	1, 2, 3
Propagation Delay Time to Logic High Output	$t_{PLH}$		25	35	ns			
Pulse Width Distortion	PWD		0	12	ns			
Propagation Delay Skew	$t_{PSK}$			15	ns			
Output Rise Time (10% to 90%)	$t_R$		10		ns			
Output Fall Time (90% to 10%)	$t_F$		10		ns			
Common Mode Transient Immunity at Logic High Output	$ CM_H $	15	25		kV/ $\mu\text{s}$	$V_{in} = 0\text{V}$ , $R_{in} = 390\Omega \pm 5\%$ , $C_{in} = 100\text{ pF}$ , $V_{cm} = 1000\text{V}$ , $T_A = 25^{\circ}\text{C}$		4
Common Mode Transient Immunity at Logic High Output	$ CM_L $	15	25		kV/ $\mu\text{s}$	$V_{in} = 4.5\text{V}$ to $5.5\text{V}$ , $R_{in} = 390\Omega \pm 5\%$ , $C_{in} = 100\text{ pF}$ , $V_{cm} = 1000\text{V}$ , $T_A = 25^{\circ}\text{C}$		5

## ACFL-6212T Low Power Mode Switching Specifications

Over recommended operating conditions:  $T_A = -40^{\circ}\text{C}$  to  $+125^{\circ}\text{C}$ ,  $3.0\text{V} \leq V_{DD} \leq 5.5\text{V}$ . All typical specifications at  $25^{\circ}\text{C}$  and  $V_{DD} = 5\text{V}$ .

Parameter	Symbol	Min.	Typ.	Max.	Unit	Test Conditions	Fig.	Note
Propagation Delay Time to Logic Low Output	$t_{PHL}$		60	100	ns	$I_F = 4\text{ mA}$ , $C_L = 15\text{ pF}$	7, 12	1, 2, 3
Propagation Delay Time to Logic High Output	$t_{PLH}$		35	100	ns			
Pulse Width Distortion	PWD		25	50	ns			
Propagation Delay Skew	$t_{PSK}$			60	ns			
Output Rise Time (10% to 90%)	$t_R$		10		ns			
Output Fall Time (90% to 10%)	$t_F$		10		ns			
Common Mode Transient Immunity at Logic High Output	$ CM_H $	25	40		kV/ $\mu\text{s}$	Using Broadcom LED Driving Circuit, $V_{IN} = 0\text{V}$ , $R_1 = 330\Omega \pm 5\%$ , $R_2 = 330\Omega \pm 5\%$ , $V_{CM} = 1000\text{V}$ , $T_A = 25^{\circ}\text{C}$		4
Common Mode Transient Immunity at Logic Low Output	$ CM_L $	25	40		kV/ $\mu\text{s}$	Using Broadcom LED Driving Circuit, $V_{IN} = 4.5$ to $5.5\text{V}$ , $R_1 = 330\Omega \pm 5\%$ , $R_2 = 330\Omega \pm 5\%$ , $V_{CM} = 1000\text{V}$ , $T_A = 25^{\circ}\text{C}$		5

## Package Characteristics

All Typical at  $T_A = 25^\circ\text{C}$ .

Parameter	Symbol	Min.	Typ.	Max.	Unit	Test Conditions	Notes
Input-Output Momentary Withstand Voltage	$V_{ISO}$	5000			$V_{RMS}$	$RH \leq 50\%$ , $t = 1 \text{ min.}$ $T_A = 25^\circ\text{C}$	6, 7
Input-Output Resistance	$R_{I-O}$		$10^{14}$		W	$V_{I-O} = 500V_{dc}$	6
Input-Output Capacitance	$C_{I-O}$		0.6		pF	$f = 1 \text{ MHz}$ , $T_A = 25^\circ\text{C}$	6

### Notes:

- $t_{PHL}$  propagation delay is measured from the 50% ( $V_{IN}$  or  $I_F$ ) on the rising edge of the input pulse to the 0.8V of  $V_{DD}$  of the falling edge of the  $V_O$  signal.  $t_{PLH}$  propagation delay is measured from the 50% ( $V_{IN}$  or  $I_F$ ) on the falling edge of the input pulse to the 80% level of the rising edge of the  $V_O$  signal.
- PWD is defined as  $|t_{PHL} - t_{PLH}|$ .
- $t_{PSK}$  is equal to the magnitude of the worst case difference in  $t_{PHL}$  and/or  $t_{PLH}$  that will be seen between units at any given temperature within the recommended operating conditions.
- $CM_H$  is the maximum tolerable rate of rise of the common mode voltage to assure that the output will remain in a high logic state.
- $CM_L$  is the maximum tolerable rate of fall of the common mode voltage to assure that the output will remain in a low logic state.
- Device considered a two terminal device: pins 1 to 6 shorted together, and pins 7 to 12 shorted together.
- In accordance with UL 1577, each optocoupler is proof tested by applying an insulation test voltage  $> 6000V_{RMS}$  for 1 second.

# Typical Performance Plots

Figure 1: Typical Diode Input Forward Current Characteristic

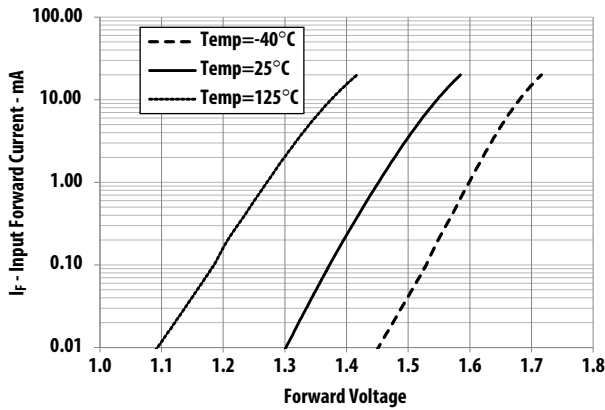

Figure 2: Typical Output Voltage vs. Input Forward Current

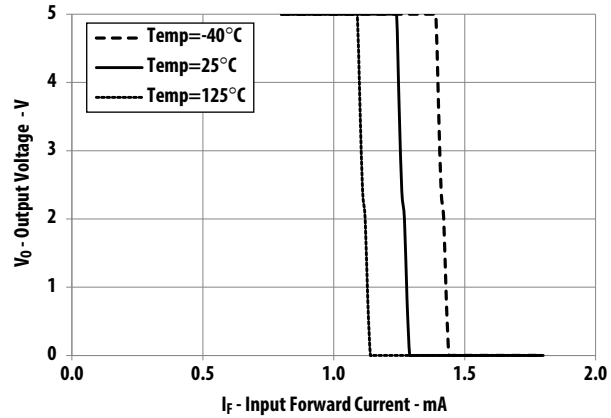

Figure 3: Typical Logic Low Output Voltage vs. Logic Low Output Current

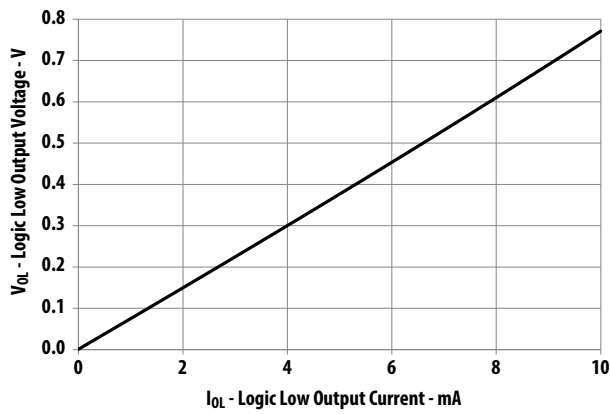

Figure 4: Typical Logic High Output Voltage vs. Logic High Output Current

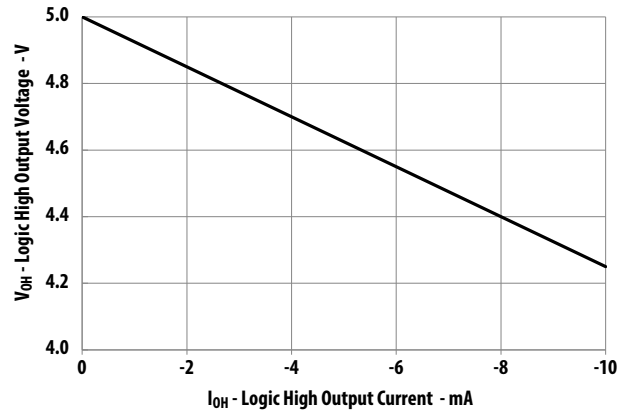

Figure 5: ACFL-6211T (High Speed) Typical Propagation Delay vs. Temperature, V<sub>IN</sub>=4.5V, R<sub>IN</sub>=390Ω, C<sub>IN</sub>=100 pF

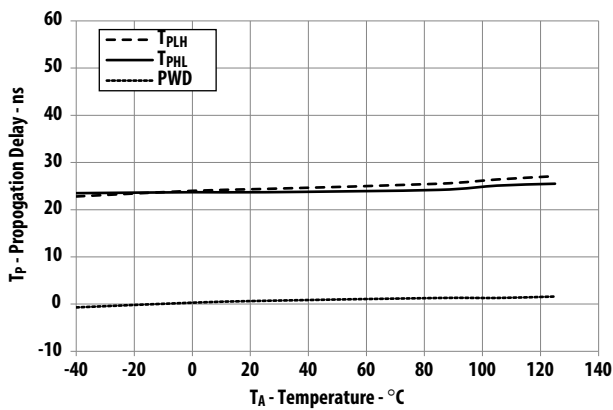

Figure 6: ACFL-6211T (High Speed) Typical Propagation Delay vs. Input Forward Current, V<sub>IN</sub>=4.5V, R<sub>IN</sub>=390Ω, C<sub>IN</sub>=100 pF, T<sub>A</sub>=25°C

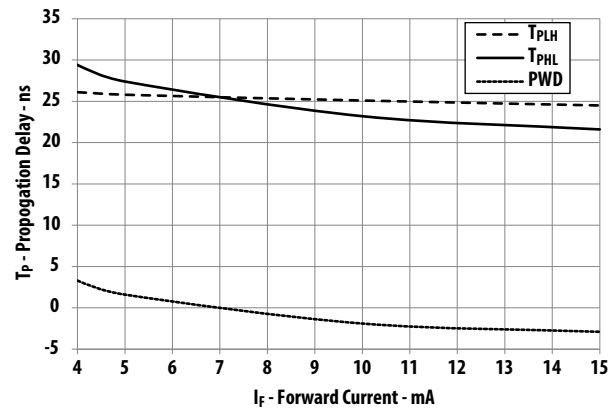



Figure 7. ACFL-6212T (5V) Typical Propagation Delay vs. Temperature

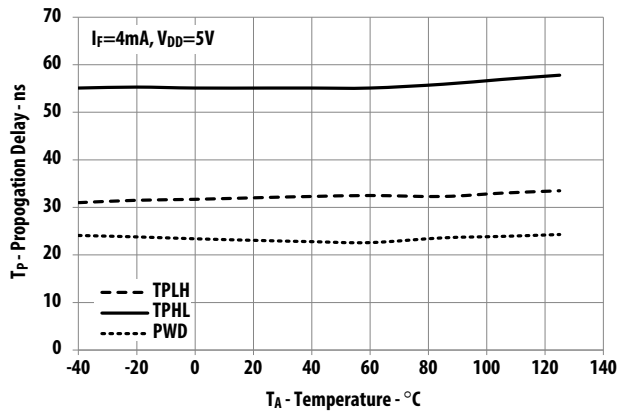

Figure 8. ACFL-6212T (5V) Typical Propagation Delay vs. Input Forward Current

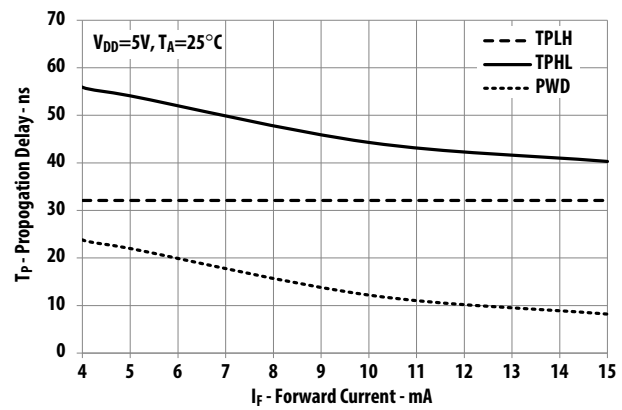

Figure 9. ACFL-6212T (3V) Typical Propagation Delay vs. Temperature

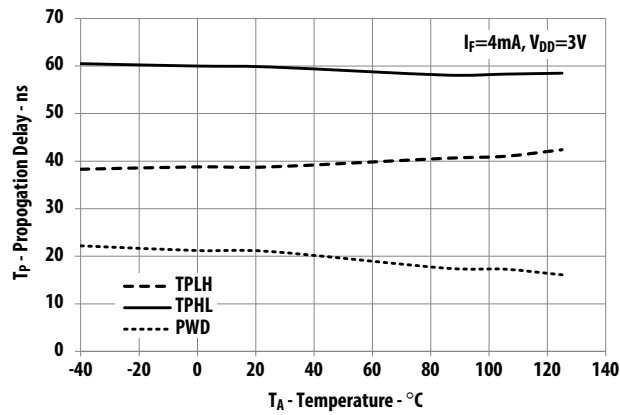
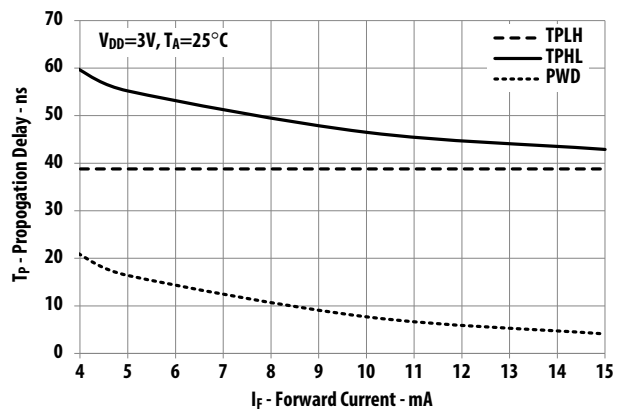
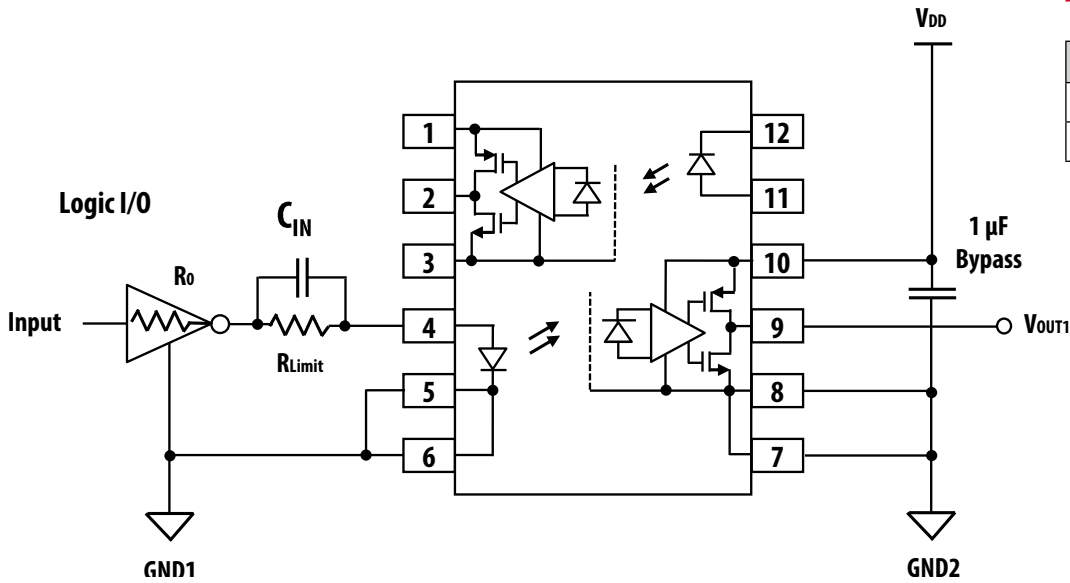

Figure 10. ACFL-6212T (3V) Typical Propagation Delay vs. Input Forward Current



# Application Circuits

Figure 11: Recommended Application Circuit for ACFL-6211T High Speed Performance



### TRUTH TABLE

INPUT	LED	OUTPUT
L	ON	L
H	OFF	H

Figure 12: Recommended Application Circuit for ACFL-6212T Low Power Performance

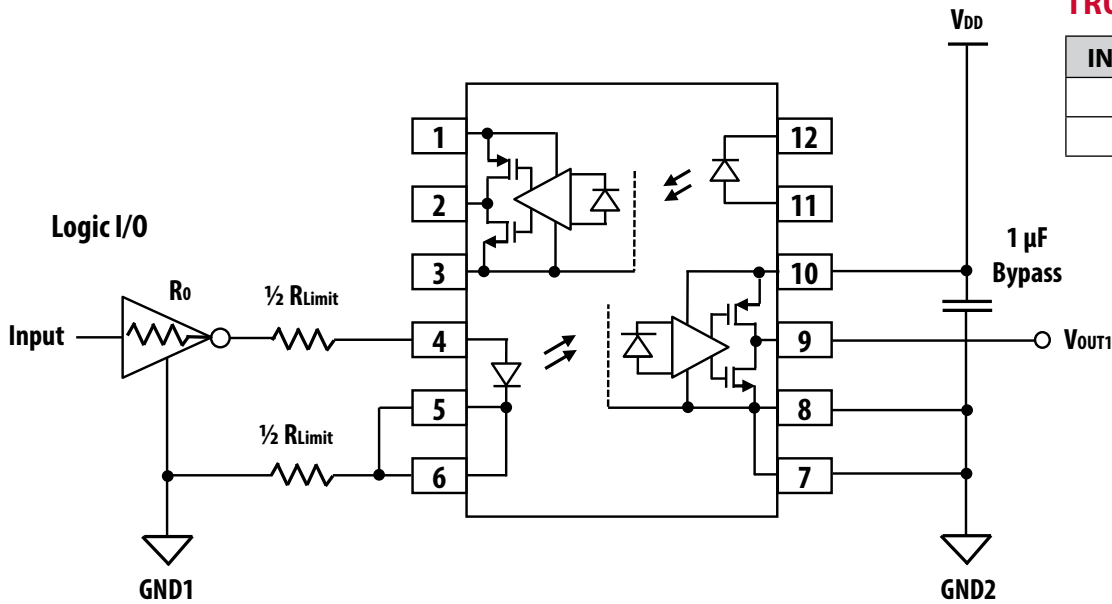

### TRUTH TABLE

INPUT	LED	OUTPUT
L	ON	L
H	OFF	H

\*C<sub>i</sub> is Approximately 15 pF, which includes Probe and Stray Wiring Capacitance

## Test Circuits

Figure 13: Test Circuit for  $t_{PHL}$ ,  $t_{PLH}$ ,  $t_F$ , and  $t_R$

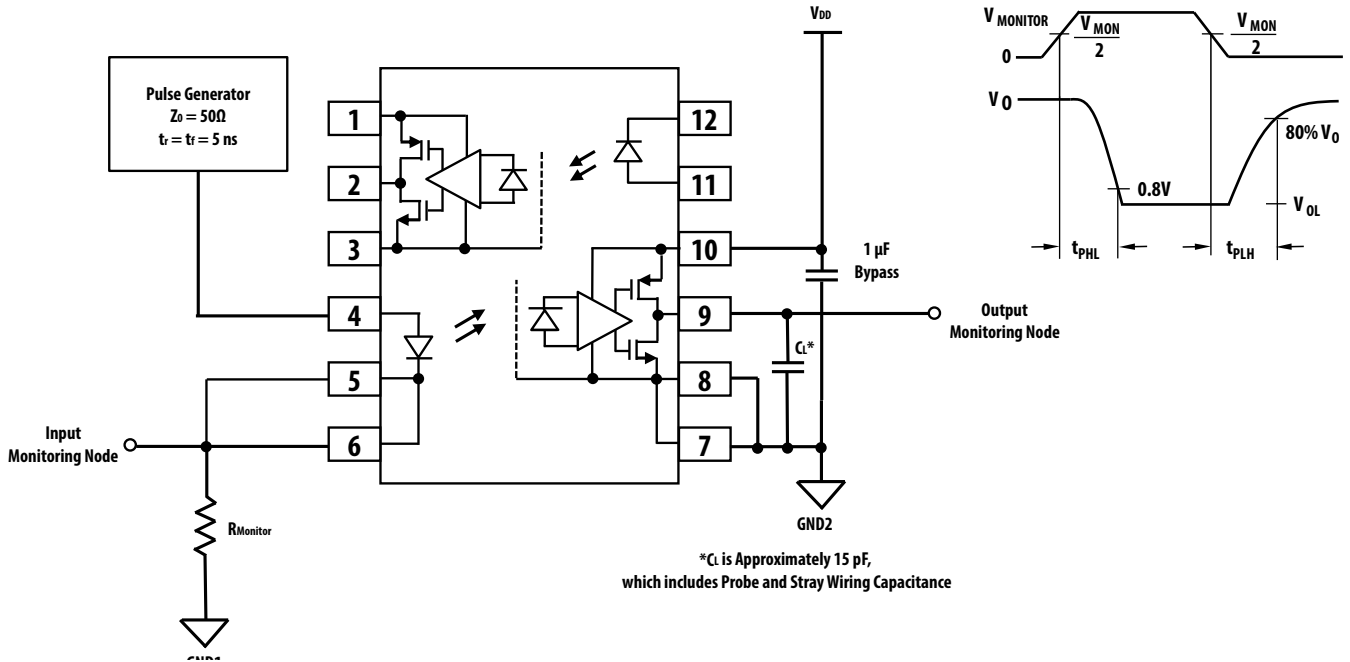
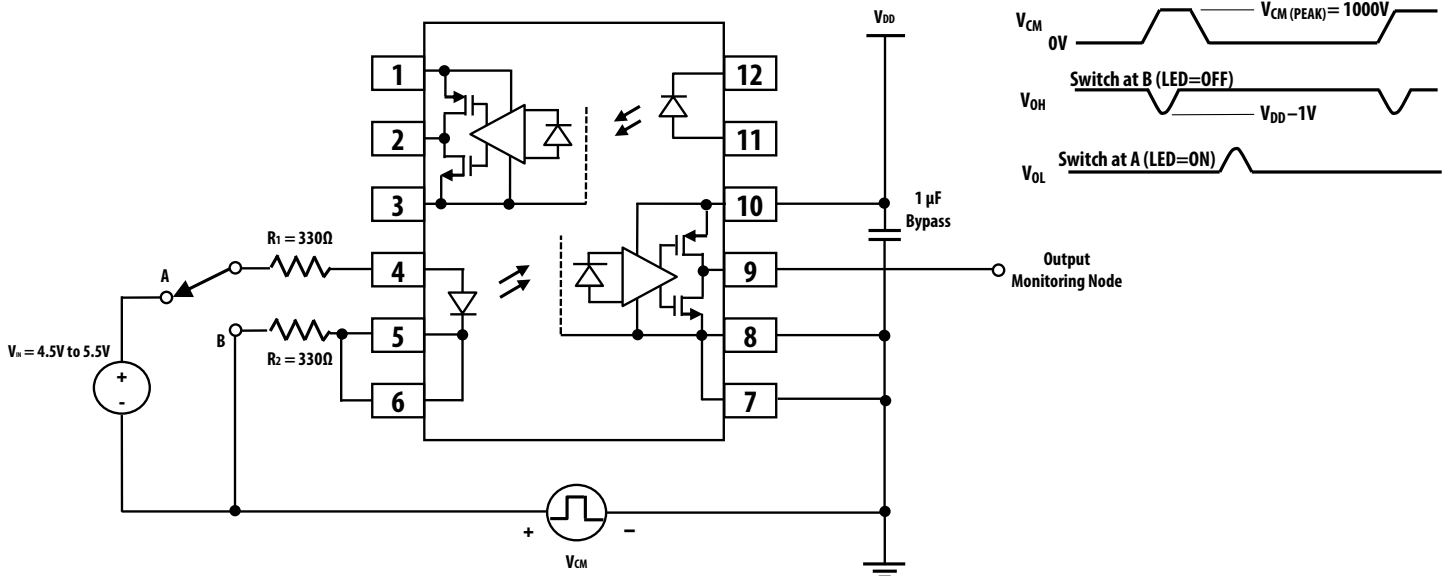

Figure 14: Test Circuit for Common Mode Transient Immunity



## Thermal Resistance Measurement

The diagram of ACFL-6211T/6212T for measurement is shown in Figure 15. This is a multi-chip package with four heat sources, the effect of heating of one die due to the adjacent dice are considered by applying the theory of linear superposition. Here, one die is heated first and the temperatures of all the dice are recorded after thermal equilibrium is reached. Then, the second die is heated and all the dice temperatures are recorded and so on until the fourth die is heated. With the known ambient temperature, the die junction temperature and power dissipation, the thermal resistance can be calculated. The thermal resistance calculation can be cast in matrix form. This yields a 4x4 matrix for our case of two heat sources.

$$\begin{array}{|c|c|c|c|} \hline R_{11} & R_{12} & R_{13} & R_{14} \\ \hline R_{21} & R_{22} & R_{23} & R_{24} \\ \hline R_{31} & R_{32} & R_{33} & R_{34} \\ \hline R_{41} & R_{42} & R_{43} & R_{44} \\ \hline \end{array} \times \begin{array}{|c|} \hline P_1 \\ \hline P_2 \\ \hline P_3 \\ \hline P_4 \\ \hline \end{array} = \begin{array}{|c|} \hline \Delta T_1 \\ \hline \Delta T_2 \\ \hline \Delta T_3 \\ \hline \Delta T_4 \\ \hline \end{array}$$

R<sub>11</sub>: Thermal Resistance of Die1 due to heating of Die1 (°C/W)  
 R<sub>12</sub>: Thermal Resistance of Die1 due to heating of Die2 (°C/W)  
 R<sub>13</sub>: Thermal Resistance of Die1 due to heating of Die3 (°C/W)  
 R<sub>14</sub>: Thermal Resistance of Die1 due to heating of Die4 (°C/W)

R<sub>21</sub>: Thermal Resistance of Die2 due to heating of Die1 (°C/W)  
 R<sub>22</sub>: Thermal Resistance of Die2 due to heating of Die2 (°C/W)  
 R<sub>23</sub>: Thermal Resistance of Die2 due to heating of Die3 (°C/W)  
 R<sub>24</sub>: Thermal Resistance of Die2 due to heating of Die4 (°C/W)

R<sub>31</sub>: Thermal Resistance of Die3 due to heating of Die1 (°C/W)  
 R<sub>32</sub>: Thermal Resistance of Die3 due to heating of Die2 (°C/W)  
 R<sub>33</sub>: Thermal Resistance of Die3 due to heating of Die3 (°C/W)  
 R<sub>34</sub>: Thermal Resistance of Die3 due to heating of Die4 (°C/W)

R<sub>41</sub>: Thermal Resistance of Die4 due to heating of Die1 (°C/W)  
 R<sub>42</sub>: Thermal Resistance of Die4 due to heating of Die2 (°C/W)  
 R<sub>43</sub>: Thermal Resistance of Die4 due to heating of Die3 (°C/W)  
 R<sub>44</sub>: Thermal Resistance of Die4 due to heating of Die4 (°C/W)

P<sub>1</sub>: Power dissipation of Die1 (W)  
 P<sub>2</sub>: Power dissipation of Die2 (W)  
 P<sub>3</sub>: Power dissipation of Die3 (W)  
 P<sub>4</sub>: Power dissipation of Die4 (W)

T<sub>1</sub>: Junction temperature of Die1 due to heat from all dice (°C)  
 T<sub>2</sub>: Junction temperature of Die2 due to heat from all dice (°C)  
 T<sub>3</sub>: Junction temperature of Die3 due to heat from all dice (°C)  
 T<sub>4</sub>: Junction temperature of Die4 due to heat from all dice (°C)

T<sub>a</sub>: Ambient temperature.

ΔT<sub>1</sub>: Temperature difference between Die1 junction and ambient (°C)

ΔT<sub>2</sub>: Temperature difference between Die2 junction and ambient (°C)

ΔT<sub>3</sub>: Temperature difference between Die3 junction and ambient (°C)

ΔT<sub>4</sub>: Temperature difference between Die4 junction and ambient (°C)

$$T_1 = (R_{11} \times P_1 + R_{12} \times P_2 + R_{13} \times P_3 + R_{14} \times P_4) + T_a \text{ -- (1)}$$

$$T_2 = (R_{21} \times P_1 + R_{22} \times P_2 + R_{23} \times P_3 + R_{24} \times P_4) + T_a \text{ -- (2)}$$

$$T_3 = (R_{31} \times P_1 + R_{32} \times P_2 + R_{33} \times P_3 + R_{34} \times P_4) + T_a \text{ -- (3)}$$

$$T_4 = (R_{41} \times P_1 + R_{42} \times P_2 + R_{43} \times P_3 + R_{44} \times P_4) + T_a \text{ -- (4)}$$

Figure 15: Diagram of ACFL-6211T/6212T for Measurement

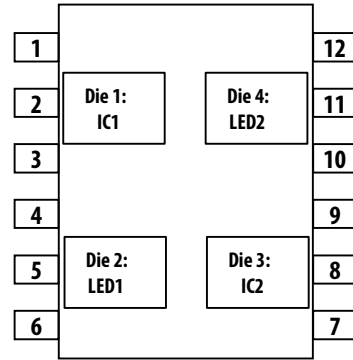

Measurement data on a low K (conductivity) board:

R<sub>11</sub> = 181 °C/W  
 R<sub>21</sub> = 103 °C/W  
 R<sub>31</sub> = 82 °C/W  
 R<sub>41</sub> = 110 °C/W  
 R<sub>12</sub> = 91 °C/W  
 R<sub>22</sub> = 232 °C/W  
 R<sub>32</sub> = 97 °C/W  
 R<sub>42</sub> = 86 °C/W  
 R<sub>13</sub> = 85 °C/W  
 R<sub>23</sub> = 109 °C/W  
 R<sub>33</sub> = 180 °C/W  
 R<sub>43</sub> = 101 °C/W  
 R<sub>14</sub> = 112 °C/W  
 R<sub>24</sub> = 91 °C/W  
 R<sub>34</sub> = 91 °C/W  
 R<sub>44</sub> = 277 °C/W

Measurement data on a high K (conductivity) board:

R<sub>11</sub> = 117 °C/W  
 R<sub>21</sub> = 37 °C/W  
 R<sub>31</sub> = 35 °C/W  
 R<sub>41</sub> = 47 °C/W  
 R<sub>12</sub> = 42 °C/W  
 R<sub>22</sub> = 161 °C/W  
 R<sub>32</sub> = 53 °C/W  
 R<sub>42</sub> = 30 °C/W  
 R<sub>13</sub> = 32 °C/W  
 R<sub>23</sub> = 39 °C/W  
 R<sub>33</sub> = 114 °C/W  
 R<sub>43</sub> = 29 °C/W  
 R<sub>14</sub> = 60 °C/W  
 R<sub>24</sub> = 33 °C/W  
 R<sub>34</sub> = 34 °C/W  
 R<sub>44</sub> = 189 °C/W