

2.5-Amp MOSFET Gate Drive Optocoupler with Integrated Desat Over Current Sensing, Active Miller Current Clamping, FAULT and UVLO Status Feedback

Data Sheet

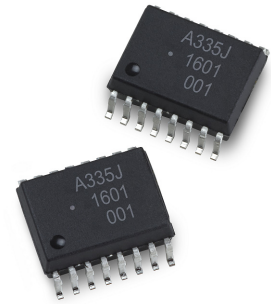

Description

The Broadcom ACPL-335J is a 2.5-A smart gate drive optocoupler device featuring fast propagation delay with excellent timing skew performance. The device supports a full set of fail-safe MOSFET diagnostics, protection and fault reporting. This full-featured and easy-to-implement gate drive optocoupler comes in a compact, surface-mountable SO-16 package.

The ACPL-335J is designed for driving power MOSFETs used in DC-DC converter, switching power supplies and battery chargers, and provides the reinforced insulation and reliability needed for critical high voltage industrial applications.

Functional Diagram

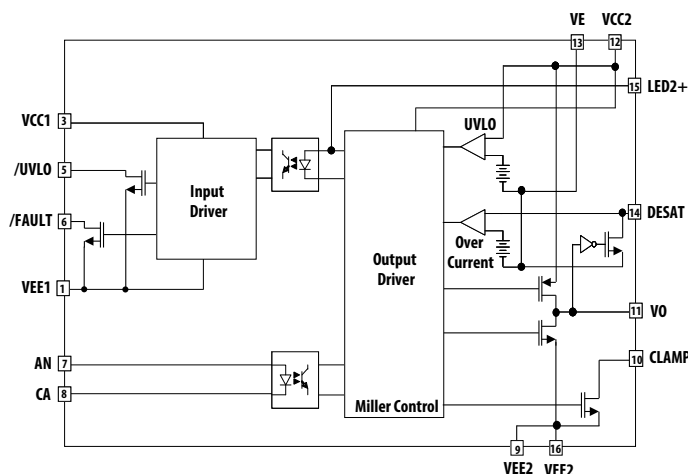

Features

- Peak output current: 2.5 A maximum
- Miller clamp sinking current: 1.9 A maximum
- Wide operating voltage: 12V to 20V
- Propagation delay: 250 ns maximum
- Dead Time Distortion: -100 ns to +20 ns
- Integrated fail-safe MOSFET protection
- Desat over current sensing, turn-off protection and fault feedback
- Under voltage lock-out protection (UVLO) with feedback
- SO-16 package with 8-mm clearance and creepage
- Temperature range: -40°C to +105°C
- Common mode rejection (CMR): >50kV/μs at $V_{CM} = 1500V$
- High noise immunity
 - Miller current clamping
 - Direct LED input with low input impedance and low noise sensitivity
 - Negative gate bias
- Regulatory approvals:
 - UL1577, CSA
 - IEC/EN/DIN EN 60747-5-5

Applications

- Isolated MOSFET gate drive
- DC-DC converter
- Switching power supplies
- Battery charging

CAUTION

It is advised that normal static precautions be taken in handling and assembly of this component to prevent damage and/or degradation that may be induced by ESD. The components featured in this data sheet are not to be used in military or aerospace applications or environments.

Ordering Information

Part Number	Option	Package	Surface Mount	Tape and Reel	IEC/EN/DIN EN 60747-5-5	Quantity
	(RoHS Compliant)					
ACPL-335J	-000E	SO-16	X		X	45 per tube
ACPL-335J	-500E		X	X	X	850 per reel

To order, choose a part number from the Part Number column and combine with the desired option from the RoHS Compliant column to form an order entry.

Example 1:

ACPL-335J-500E to order product of SO-16 Surface Mount package in Tape and Reel packaging with IEC/EN/DIN EN 60747-5-5 Safety Approval in RoHS compliant.

Option data sheets are available. Contact your Broadcom sales representative or authorized distributor for information.

Package Outline Drawings

16-Lead Surface Mount

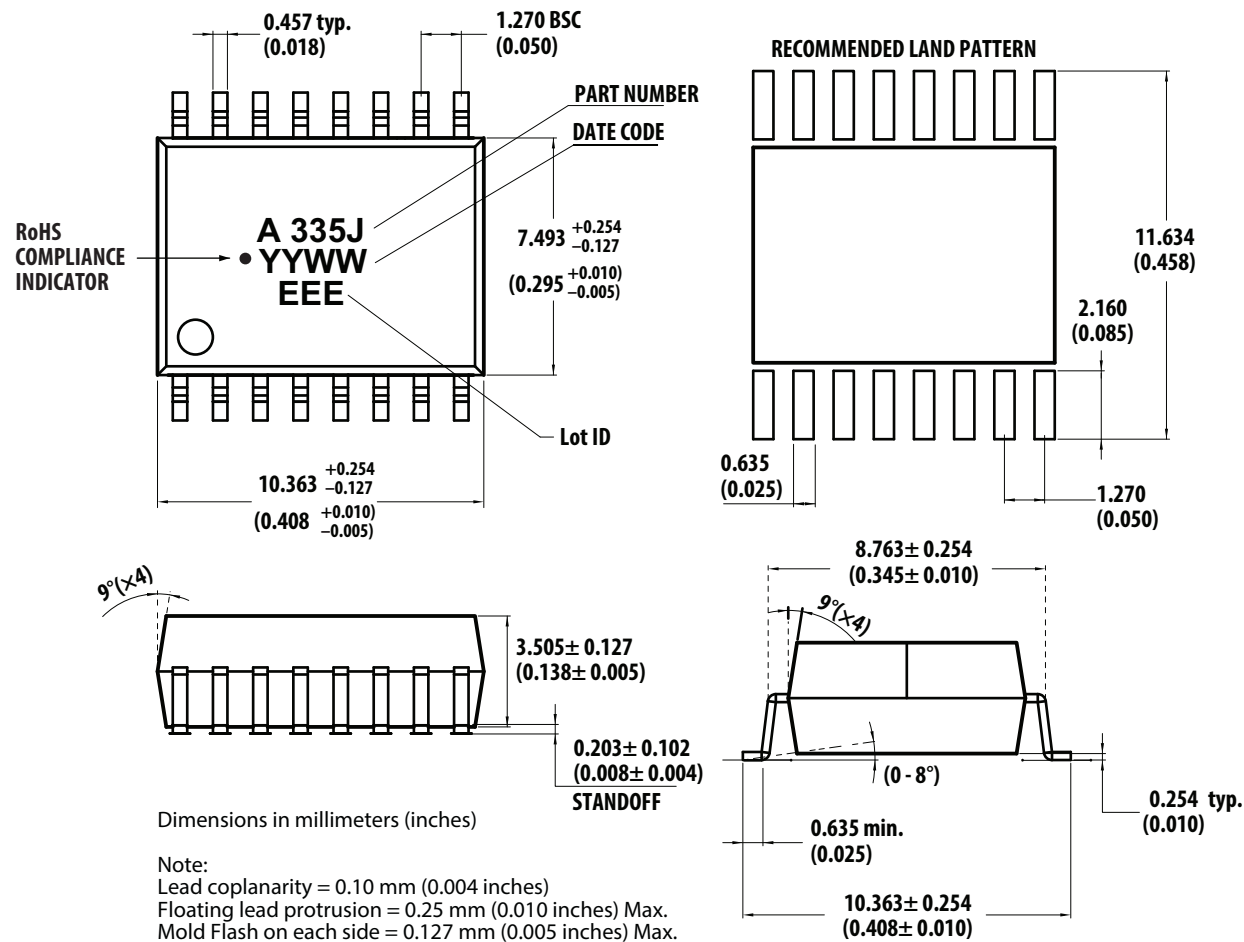

Recommended Lead-free IR Profile

Recommended reflow condition as per JEDEC Standard, J-STD-020 (latest revision).

Non-halide flux should be used.

Product Overview Description

The ACPL-335J is a highly integrated power control device that incorporates all the necessary components for a complete, isolated MOSFET gate drive circuit. It features desaturation sensing with shutdown protection and fault feedback, under voltage lock-out and feedback and active Miller current clamping in a SO-16 package. Direct LED input allows flexible logic configuration and differential current mode driving with low input impedance, greatly increased its noise immunity.

Package Pin Out

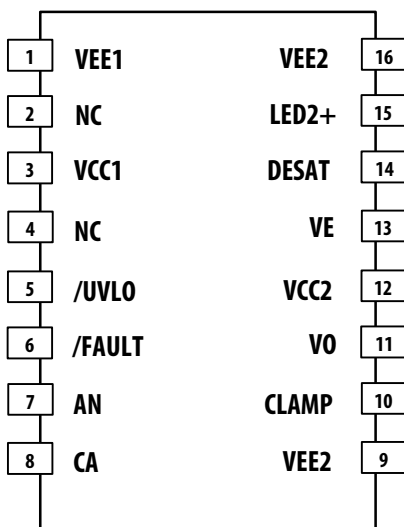

Pin Description

Pin Name	Function	Pin Name	Function
VEE1	Input common	VEE2	Negative power supply
NC	No connection	LED2+	No connection, for testing only
VCC1	Input power supply	DESAT	Desat over current sensing
NC	No connection	VE	MOSFET source reference
/UVLO	VCC2 under voltage lock-out feedback	VCC2	Positive power supply
/FAULT	Over current fault feedback	VO	Driver output to MOSFET gate
AN	Input LED anode	CLAMP	Miller current clamping output
CA	Input LED cathode	VEE2	Negative power supply

Regulatory Information

The ACPL-335J is approved by the following organizations:

UL	Approved under UL 1577, component recognition program up to $V_{ISO} = 5000 V_{RMS}$
CSA	Approved under CSA Component Acceptance Notice #5, File CA 88324.
IEC/EN/DIN EN 60747-5-5	Approved under IEC 60747-5-5, EN 60747-5-5, DIN EN 60747-5-5

IEC/EN/DIN EN 60747-5-5 Insulation Characteristics

Description	Symbol	Characteristic	Units
Insulation Classification per DIN VDE 0110/1.89, Table 1 for rated mains voltage $\leq 150 V_{rms}$ for rated mains voltage $\leq 300 V_{rms}$ for rated mains voltage $\leq 600 V_{rms}$ for rated mains voltage $\leq 1000 V_{rms}$		I – IV I – IV I – IV I – III	
Climatic Classification		40/105/21	
Pollution Degree (DIN VDE 0110/1.89)		2	
Maximum Working Insulation Voltage	V_{IORM}	1230	V_{PEAK}
Input to Output Test Voltage, Method b ^a $V_{IORM} \times 1.875 = V_{PR}$, 100% Production Test with $t_m = 1s$, Partial discharge $< 5 pC$	V_{PR}	2306	V_{PEAK}
Input to Output Test Voltage, Method a ^a $V_{IORM} \times 1.6 = V_{PR}$, Type and Sample Test, $t_m = 10s$, Partial Discharge $< 5 pC$	V_{PR}	1968	V_{PEAK}
Highest Allowable Overvoltage (Transient Overvoltage $t_{ini} = 60s$)	V_{IOTM}	8000	V_{PEAK}
Safety-limiting values – maximum values allowed in the event of a failure Case Temperature Input Power Output Power	T_S $P_{S,INPUT}$ $P_{S,OUTPUT}$	175 400 1200	$^{\circ}C$ mW mW
Insulation Resistance at $T_S, V_{IO} = 500V$	R_S	$> 10^9$	Ohm

- a. Refer to IEC/EN/DIN EN 60747-5-5 Optoisolator Safety Standard section of the *Broadcom Regulatory Guide to Isolation Circuits*, AV02-2041EN, for a detailed description of Method a and Method b partial discharge test profiles.

NOTE Isolation characteristics are guaranteed only within the safety maximum ratings which must be ensured by protective circuits in application. Surface mount classification is class A in accordance with CECC00802.

Insulation and Safety Related Specifications

Parameter	Symbol	Value	Units	Conditions
Minimum External Air Gap (Clearance)	L(101)	8.3	mm	Measured from input terminals to output terminals, shortest distance through air.
Minimum External Tracking (Creepage)	L(102)	8.3	mm	Measured from input terminals to output terminals, shortest distance path along body.
Minimum Internal Plastic Gap (Internal Clearance)		0.5	mm	Through insulation distance conductor to conductor, usually the straight line distance thickness between the emitter and detector.
Tracking Resistance (Comparative Tracking Index)	CTI	>175	V	DIN IEC 112/VDE 0303 Part 1
Isolation Group		IIIa		Material Group (DIN VDE 0110)

Absolute Maximum Ratings

Unless otherwise specified, all voltages at input IC reference to V_{EE1} , all voltages at output IC reference to V_{EE2} .

Parameter	Symbol	Min.	Max.	Units	Note
Storage Temperature	T_S	-55	125	°C	
Operating Temperature	T_A	-40	105	°C	
IC Junction Temperature	T_J	—	125	°C	a
Average Input Current	$I_{F(AVG)}$	—	20	mA	
Peak Transient Input Current (<1- μ s pulse width, 300 pps)	$I_{F(TRAN)}$	—	1	A	
Reverse Input Voltage	V_R	—	6	V	
/Fault Output Current (Sinking)	$I_{/FAULT}$	—	10	mA	
/Fault Pin Voltage	$V_{/FAULT}$	-0.5	6	V	
/UVLO Output Current (Sinking)	$I_{/UVLO}$	—	10	mA	
/UVLO Pin Voltage	$V_{/UVLO}$	-0.5	6	V	
Positive Input Supply Voltage	V_{CC1}	-0.5	26	V	
Total Output Supply Voltage	V_{CC2}	-0.5	30	V	
Negative Output Supply Voltage	$V_{EE2} - V_E$	-10	0.5	V	b
Positive Output Supply Voltage	$V_{CC2} - V_E$	-0.5	30	V	
Gate Drive Output Voltage	$V_{O(peak)}$	-0.5	$V_{CC2}+0.5$	V	
Peak Output Current	$ I_{O(peak)} $	—	2.5	A	c
Peak Clamping Sinking Current	I_{CLAMP}	—	2	A	c
Miller Clamping Pin Voltage	$V_{CLAMP} - V_{EE2}$	-0.5	$V_{CC2}+0.5$	V	
Desat Voltage	$V_{DESAT} - V_E$	$V_E - 0.5$	$V_{CC2}+0.5$	V	d
Desat Discharging Current (Continuous)	I_{DSCHG}	—	5	mA	
Output IC Power Dissipation	P_O	—	580	mW	a
Input IC Power Dissipation	P_I	—	150	mW	

- Output IC power dissipation is derated linearly above 95°C from 580 mW to 380 mW at 105°C based on the thermal characteristic on page 11.
- This supply is optional. Required only when negative gate drive is implemented.
- Maximum pulse width = 1 μ s, maximum duty cycle = 1%.
- Maximum 500-ns pulse width if peak $V_{DESAT} > 10V$.

Recommended Operating Conditions

Parameter	Symbol	Min.	Max.	Units	Notes
Operating Temperature	T_A	-40	105	°C	
Input Supply Voltage	$V_{CC1} - V_{EE1}$	8	18	V	
Total Output Supply Voltage	$V_{CC2} - V_{EE2}$	12	20	V	a
Negative Output Supply Voltage	$V_{EE2} - V_E$	-8	0	V	b
Positive Output Supply Voltage	$V_{CC2} - V_E$	12	20	V	
Input LED Current	$I_{F(ON)}$	10	16	mA	
Input Voltage (OFF)	$V_{F(OFF)}$	-5.5	0.8	V	
Input pulse width	$t_{ON(LED)}$	500	—	ns	

a. 12V is the recommended minimum operating positive supply voltage ($V_{CC2} - V_E$) to ensure adequate margin in excess of the maximum V_{UVLO+} threshold of 11.2V.

b. Maximum pulse width = 1 μ s, maximum duty cycle = 1%

Electrical and Switching Specifications

Unless otherwise specified, all Minimum/Maximum specifications are at recommended operating conditions. All typical values at $T_A = 25^\circ\text{C}$, $V_{CC1} = 12\text{V}$, $V_{CC2} - V_{EE2} = 13\text{V}$, $V_E - V_{EE2} = 0\text{V}$. All voltages at input IC reference to V_{EE1} , all voltages at output IC reference to V_{EE2} .

Parameter	Symbol	Min.	Typ.*	Max.	Units	Test Conditions	Fig.	Notes
IC Supply Current								
Input Supply Current	I_{CC1}	—	3.7	6.0	mA		1	
Output Low Supply Current	I_{CC2L}	—	10.5	13.2	mA	$I_F = 0\text{ mA}$	2	
Output High Supply Current	I_{CC2H}	—	10.6	13.6	mA	$I_F = 10\text{ mA}$	2	
Logic Input and Output								
LED Forward Voltage	V_F	1.25	1.55	1.85	V	$I_F = 10\text{ mA}$	3	
LED Reverse Breakdown Voltage	V_{BR}	6	—	—	V	$I_F = -10\text{ }\mu\text{A}$		
Input Capacitance	C_{IN}	—	90	—	pF	—		
LED Turn on Current Threshold, Low to High	I_{TH+}	—	2.7	6.6	mA	$V_O = 5\text{ V}$	4	
LED Turn on Current Threshold, High to Low	I_{TH-}	—	2.1	6.4	mA	$V_O = 5\text{ V}$	4	
LED Turn on Current Hysteresis	I_{TH_HYS}	—	0.6	—	mA	—		
/FAULT Logic Low Output Current	I_{FAULT_L}	4.0	9.0	—	mA	$V_{/FAULT} = 0.4\text{ V}$		
/FAULT Logic High Output Current	I_{FAULT_H}	—	—	20	μA	$V_{/FAULT} = 5\text{ V}$		
/UVLO Logic Low Output Current	I_{UVLO_L}	4.0	9.0	—	mA	$V_{/UVLO} = 0.4\text{ V}$		
/UVLO Logic High Output Current	I_{UVLO_H}	—	—	20	μA	$V_{/UVLO} = 5\text{ V}$		
Gate Driver								
High Level Output Current	I_{OH}	—	-2.0	-0.75	A	$V_O = V_{CC2} - 3\text{ V}$	5	a
Low Level Output Current	I_{OL}	1.0	2.2	—	A	$V_O = V_{EE2} + 2.5\text{ V}$	6	a
High Level Output Voltage	V_{OH}	$V_{CC2} - 0.5$	$V_{CC2} - 0.2$	—	V	$I_O = -100\text{ mA}$		b, c, d

Parameter	Symbol	Min.	Typ.*	Max.	Units	Test Conditions	Fig.	Notes
Low Level Output Voltage	V_{OL}		0.1	0.5	V	$I_O = 100 \text{ mA}$		
VIN to High Level Output Propagation Delay Time	t_{PLH}	50	110	250	ns	$V_{source} = 3.3V$, $R_f = 140 \Omega$, $R_g = 10 \Omega$, $C_{load} = 1 \text{ nF}$, $f = 200 \text{ kHz}$, Duty Cycle = 50%	7, 10	e
VIN to Low Level Output Propagation Delay Time	t_{PHL}	50	150	250	ns		f	
Pulse Width Distortion ($t_{PHL} - t_{PLH}$)	PWD	-20		100	ns		g, h	
Dead Time Distortion ($t_{PLH} - t_{PHL}$)	DTD	-100		20	ns		h, i	
10% to 90% Rise Time	t_R		60		ns			
90% to 10% Fall Time	t_F		50		ns			
Output High Level Common Mode Transient Immunity	$ CM_H $	50	>70		kV/ μ s	$T_A = 25^\circ\text{C}$, $V_{CM} = 1500V$, $V_{CC2} = 20V$	11	j
Output Low Level Common Mode Transient Immunity	$ CM_L $	50	>70		kV/ μ s	$T_A = 25^\circ\text{C}$, $V_{CM} = 1500V$, $V_{CC2} = 20V$	12	k
Active Miller Clamp								
Clamp Threshold Voltage	V_{TH_CLAMP}		2.0	3.0	V	—		
Clamp Low Level Sinking Current	I_{CLAMP}	0.75	1.9		A	$V_{CLAMP} = V_{EE2} + 2.5V$		
V_{CC2} UVLO Protection (UVLO voltage V_{UVLO} reference to V_E)								
V_{CC2} UVLO Threshold Low to High	V_{UVLO+}	8.8	10	11.2	V	$V_O > 5V$		d, l
V_{CC2} UVLO Threshold High to Low	V_{UVLO-}	7.8	9	10.2	V	$V_O < 5V$		d, m
V_{CC2} UVLO Hysteresis	V_{UVLO_HYS}		1		V			
V_{CC2} to UVLO High Delay	t_{PLH_UVLO}		10		μ s			n
V_{CC2} to UVLO Low Delay	t_{PHL_UVLO}		10		μ s			o
V_{CC2} UVLO to V_{OUT} High Delay	t_{UVLO_ON}		10		μ s			p
V_{CC2} UVLO to V_{OUT} Low Delay	t_{UVLO_OFF}		10		μ s			q
V_{CC2} UVLO Threshold Low to High	V_{UVLO+}	8.8	10	11.2	V	$V_O > 5V$		d, l
Desaturation Protection (Desat voltage V_{DESAT} reference to V_E)								
Desat Sensing Threshold	V_{DESAT}	3.4	3.9	4.4	V		8	d
Desat Discharging Current (Pulsed)	I_{DSCHG}	20	53		mA	$V_{DESAT} = 5V$	9	
Internal Desat Blanking Time	$t_{DESAT(BLANKING)}$	0.2	0.4	0.6	μ s	Load = 1 nF	17	r
Desat Sense to 90% VO Delay	$t_{DESAT(90\%)}$		0.15	0.5	μ s		17	s
Desat to Low Level FAULT Signal Delay	$t_{DESAT(FAULT)}$			7	μ s		17	t
Output Mute Time due to Desat	$t_{DESAT(MUTE)}$	2.3	3.2	5	ms		17	u
Time for Input Kept Low Before Fault Reset to High	$t_{DESAT(RESET)}$	2.3	3.2	5	ms		17	v

- Maximum 500-ns pulse width if peak $V_{DESAT} > 10V$.
- For High Level Output Voltage testing, V_{OH} is measured with a DC load current. When driving capacitive loads, V_{OH} will approach V_{CC} as I_{OH} approaches zero.
- Maximum pulse width = 1.0 ms, maximum duty cycle = 20%.
- Once V_O of the ACPL-335J is allowed to go high ($V_{CC2} - V_E > V_{UVLO}$), the DESAT detection feature of the ACPL-335J will be the primary source of IGBT protection. UVLO is needed to ensure DESAT is functional. Once V_{CC2} exceeds V_{UVLO+} threshold, DESAT will remain functional until V_{CC2} is below V_{UVLO-} threshold. Thus, the DESAT detection and UVLO features of the ACPL-335J work in conjunction to ensure constant IGBT protection.

- e. t_{PLH} is defined as propagation delay from 50% of LED input I_F to 50% of High level output.
- f. t_{PHL} is defined as propagation delay from 50% of LED input I_F to 50% of Low level output.
- g. Pulse Width Distortion (PWD) is defined as $(t_{PHL} - t_{PLH})$ of any given unit.
- h. As measured from I_F to V_O .
- i. Dead Time Distortion (DTD) is defined as $(t_{PLH} - t_{PHL})$ between any two ACPL-335J parts under the same test conditions.
- j. Common mode transient immunity in the high state is the maximum tolerable dV_{CM}/dt of the common mode pulse, V_{CM} , to assure that the output will remain in the high state (that is, $V_O > 12V$).
- k. Common mode transient immunity in the low state is the maximum tolerable dV_{CM}/dt of the common mode pulse, V_{CM} , to assure that the output will remain in a low state (that is, $V_O < 1.0V$).
- l. This is the "increasing" (that is, turn-on or "positive going" direction) of $V_{CC2} - V_E$.
- m. This is the "decreasing" (that is, turn-off or "negative going" direction) of $V_{CC2} - V_E$.
- n. The delay time when V_{CC2} exceeds UVLO+ threshold to UVLO High – 50% of UVLO positive-going edge.
- o. The delay time when V_{CC2} falls below UVLO- threshold to UVLO Low – 50% of UVLO negative-going edge.
- p. The delay time when V_{CC2} exceeds UVLO+ threshold to 50% of High level output.
- q. The delay time when V_{CC2} falls below UVLO- threshold to 50% of Low level output.
- r. The delay time for ACPL-335J to respond to a DESAT fault condition without any external DESAT capacitor.
- s. The amount of time from when DESAT threshold is exceeded to 90% of VGATE at mentioned test conditions.
- t. The amount of time from when DESAT threshold is exceeded to FAULT output Low – 50% of V_{CC1} voltage.
- u. The amount of time when DESAT threshold is exceeded, Output is mute to LED input.
- v. The amount of time when DESAT Mute time is expired, LED input must be kept Low for Fault status to return to High.

Package Characteristics

Parameter	Symbol	Min.	Typ.	Max.	Units	Test Conditions	Note
Input-Output Momentary Withstand Voltage	V_{ISO}	5000			V_{RMS}	$RH < 50\%$, $t = 1 \text{ min.}$, $T_A = 25^\circ\text{C}$	a, b, c
Resistance (Input-Output)	R_{I-O}		10^{14}		Ω	$V_{I-O} = 500 V_{DC}$	c
Capacitance (Input-Output)	C_{I-O}		1.3		pF	$f = 1 \text{ MHz}$	
Thermal coefficient between LED and input IC	A_{EI}		35.4		$^\circ\text{C/W}$		
Thermal coefficient between LED and output IC	A_{EO}		33.1		$^\circ\text{C/W}$		
Thermal coefficient between input IC and output IC	A_{IO}		25.6		$^\circ\text{C/W}$		
Thermal coefficient between LED and Ambient	A_{EA}		176.1		$^\circ\text{C/W}$		
Thermal coefficient between input IC and Ambient	A_{IA}		92		$^\circ\text{C/W}$		
Thermal coefficient between output IC and Ambient	A_{OA}		76.7		$^\circ\text{C/W}$		

- a. In accordance with UL1577, each optocoupler is proof tested by applying an insulation test voltage $\geq 6000 V_{RMS}$ for 1 second.
- b. The Input-Output Momentary Withstand Voltage is a dielectric voltage rating that should not be interpreted as an input-output continuous voltage rating. For the continuous voltage rating, refer to your equipment level safety specification or IEC/EN/DIN EN 60747-5-5 Insulation Characteristics Table.
- c. Device considered a two terminal device: pins 1–8 shorted together and pins 9–16 shorted together.

Thermal Characteristics

Thermal characteristics are based on the ground planes layout of the evaluation PCB.

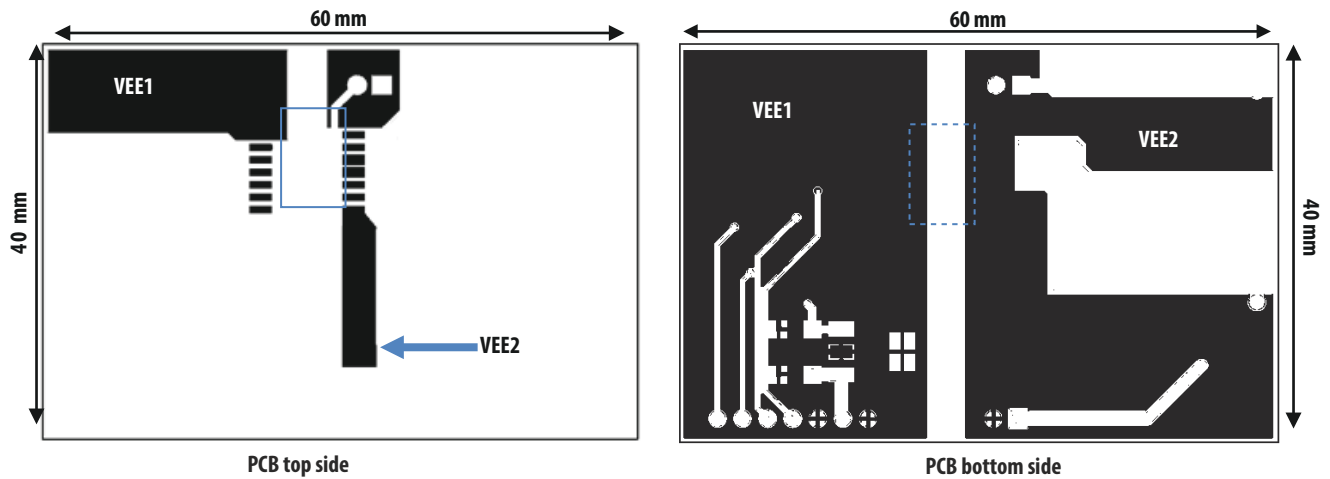

Notes on Thermal Calculation

Application and environmental design for ACPL-335J needs to ensure that the junction temperature of the internal ICs and LED within the gate driver optocoupler do not exceed 125°C. The following equations calculate the maximum power dissipation and corresponding effect on junction temperatures and can only be used as a reference for thermal performance comparison under specified PCB layout as shown above. The thermal resistance model shown here is not meant to and will not predict the performance of a package in an application-specific environment.

$$\text{LED Junction Temperature} = A_{EA} \times P_E + A_{EI} \times P_I + A_{EO} \times P_O + T_A$$

$$\text{Input IC Junction Temperature} = A_{EI} \times P_E + A_{IA} \times P_I + A_{IO} \times P_O + T_A$$

$$\text{Output IC Junction Temperature} = A_{EO} \times P_E + A_{IO} \times P_I + A_{OA} \times P_O + T_A$$

P_E – LED Power Dissipation

P_I – Input IC Power Dissipation

P_O – Output IC Power Dissipation

Calculation of LED Power Dissipation

LED Power Dissipation, $P_E = I_{F(\text{LED})} (\text{Recommended Max}) \times V_{F(\text{LED})} \times \text{Duty Cycle}$

Example: $P_E = 16 \text{ mA} \times 1.25 \text{ V} \times 50\% \text{ duty cycle} = 10 \text{ mW}$

Calculation of Input IC Power Dissipation

Input IC Power Dissipation, $P_I = I_{CC1} (\text{Max}) \times V_{CC1} (\text{Recommended Max})$

Example: $P_I = 6 \text{ mA} \times 18 \text{ V} = 108 \text{ mW}$

Calculation of Output IC Power Dissipation

Output IC Power Dissipation, $P_O = V_{CC2} \text{ (Recommended Max)} \times I_{CC2} \text{ (Max)} + P_{HS} + P_{LS}$

P_{HS} – High Side Switching Power Dissipation

P_{LS} – Low Side Switching Power Dissipation

$$P_{HS} = (V_{CC2} \times Q_G \times f_{PWM}) \times R_{OH(MAX)} / (R_{OH(MAX)} + R_{GH}) / 2$$

$$P_{LS} = (V_{CC2} \times Q_G \times f_{PWM}) \times R_{OL(MAX)} / (R_{OL(MAX)} + R_{GL}) / 2$$

Q_G – Gate Charge at Supply Voltage

f_{PWM} – LED Switching Frequency

$R_{OH(MAX)}$ – Maximum High Side Output Impedance – $V_{OH(MIN)} / I_{OH(MIN)}$

R_{GH} – Gate Charging Resistance

$R_{OL(MAX)}$ – Maximum Low Side Output Impedance – $V_{OL(MIN)} / I_{OL(MIN)}$

R_{GL} – Gate Discharging Resistance

Example:

$$R_{OH(MAX)} = (V_{CC2} - V_{OH(MIN)}) / I_{OH(MIN)} = 3V / 0.75A = 4\Omega$$

$$R_{OL(MAX)} = V_{OL(MIN)} / I_{OL(MIN)} = 2.5V / 1A = 2.5\Omega$$

$$P_{HS} = (20V \times 100 \text{ nC} \times 200 \text{ kHz}) \times 4\Omega / (4\Omega + 10\Omega) / 2 = 57.14 \text{ mW}$$

$$P_{LS} = (20V \times 100 \text{ nC} \times 200 \text{ kHz}) \times 2.5\Omega / (2.5\Omega + 10\Omega) / 2 = 40 \text{ mW}$$

$$P_O = 20V \times 13.6 \text{ mA} + 57.14 \text{ mW} + 40 \text{ mW} = 360.14 \text{ mW}$$

Calculation of Junction Temperature

$$\text{LED Junction Temperature} = 176.1^\circ\text{C/W} \times 10 \text{ mW} + 35.4^\circ\text{C/W} \times 108 \text{ mW} + 33.1 \times 360.14 \text{ mW} + T_A = 17.5^\circ\text{C} + T_A$$

$$\text{Input IC Junction Temperature} = 35.4^\circ\text{C/W} \times 10 \text{ mW} + 92^\circ\text{C/W} \times 108 \text{ mW} + 25.6 \times 360.14 \text{ mW} + T_A = 19.5^\circ\text{C} + T_A$$

$$\text{Output IC Junction Temperature} = 33.1^\circ\text{C/W} \times 10 \text{ mW} + 25.6^\circ\text{C/W} \times 108 \text{ mW} + 76.7 \times 360.14 \text{ mW} + T_A = 30.7^\circ\text{C} + T_A$$

Typical Performance Plots

Figure 1 I_{CC1} across Temperature

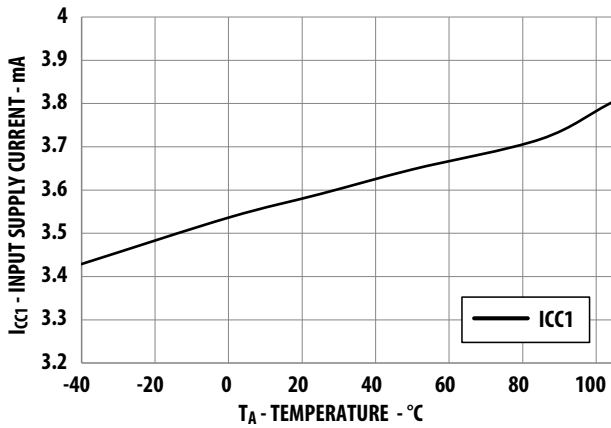

Figure 2 I_{CC2} across Temperature

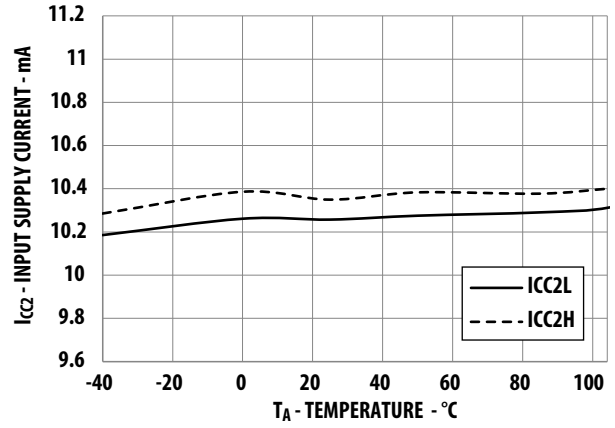

Figure 3 I_F vs V_F

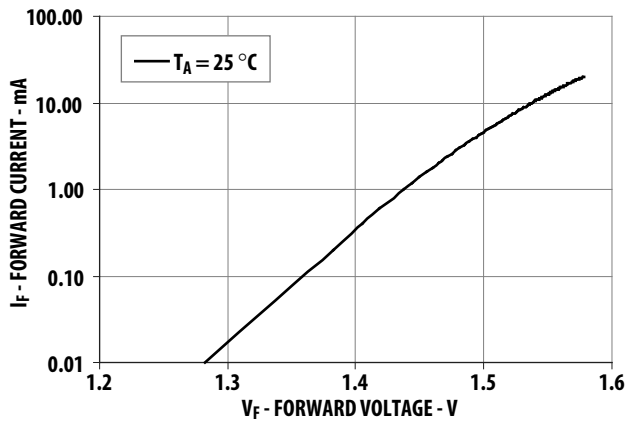

Figure 4 I_{TH} across Temperature

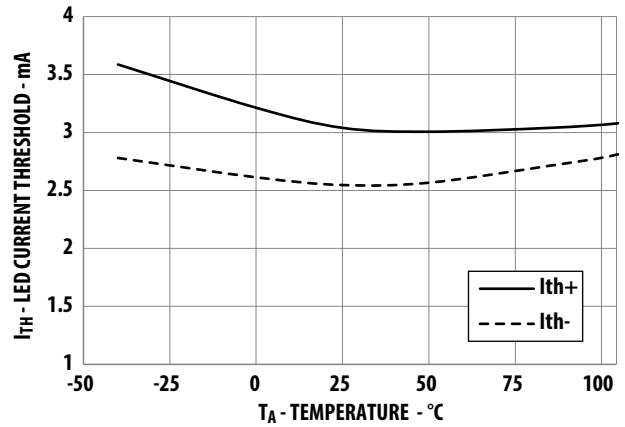

Figure 5 V_{OH} vs I_{OH}

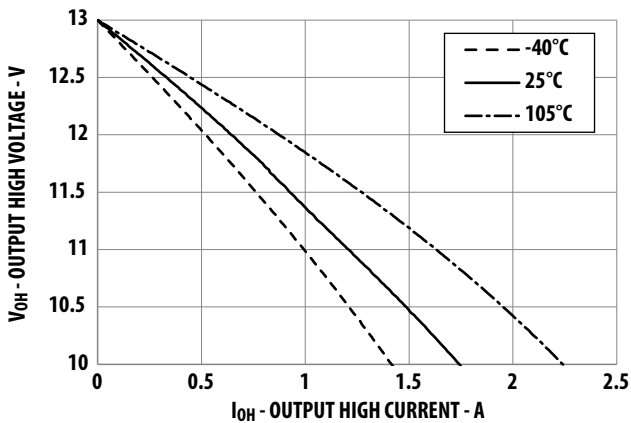

Figure 6 V_{OL} vs I_{OL}

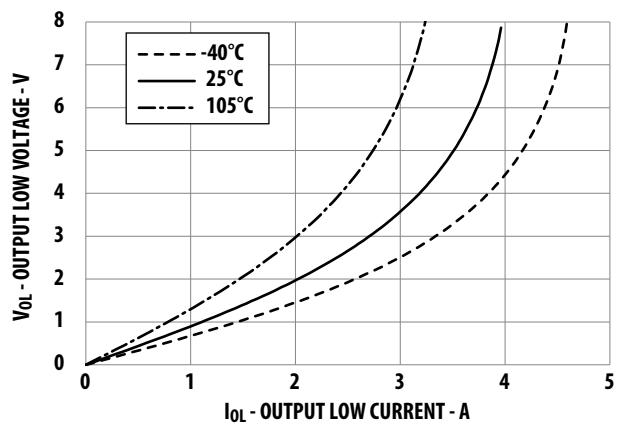

Figure 7 T_p across Temperature

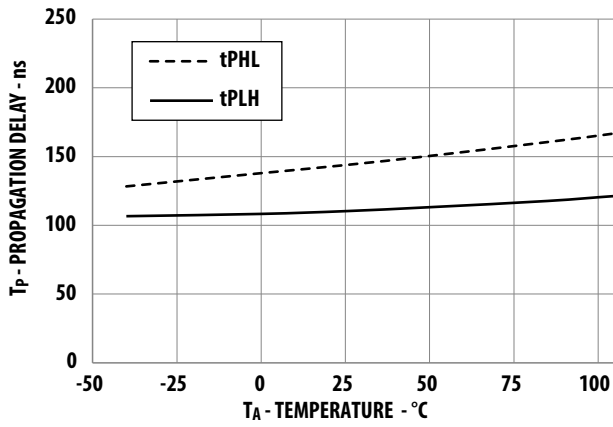

Figure 8 V_{DESAT} Threshold across Temperature

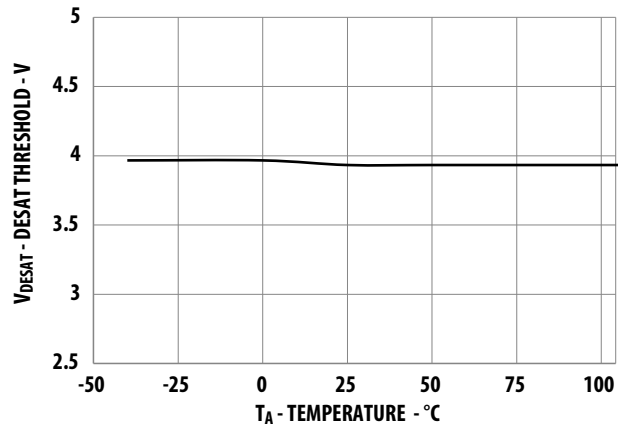

Figure 9 I_{DSCHG} across Temperature

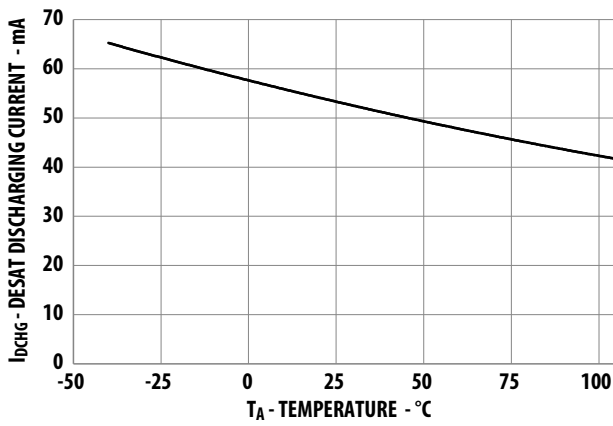

Figure 10 Propagation Delay Test Circuit and Timing Diagram

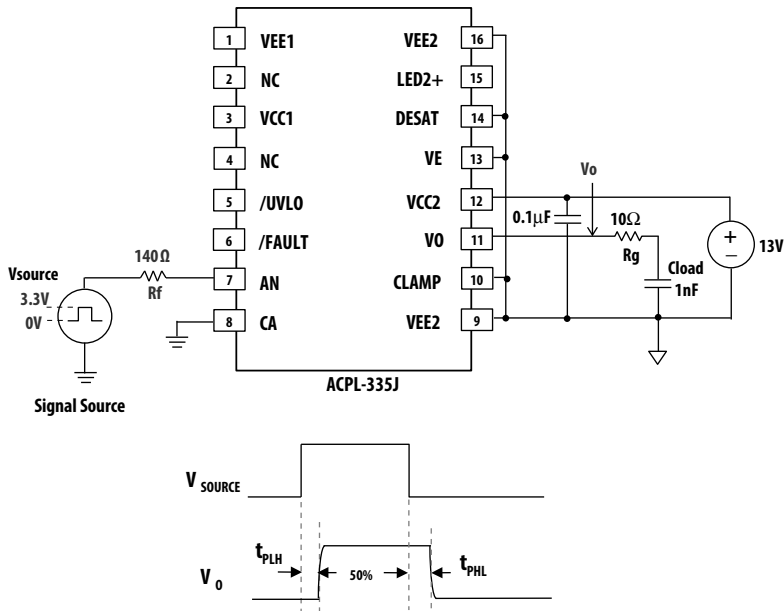

Figure 11 CMR Vo High Test Circuit

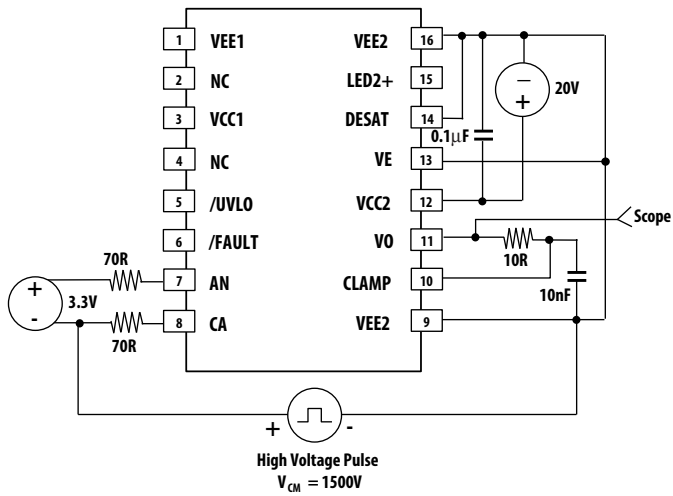
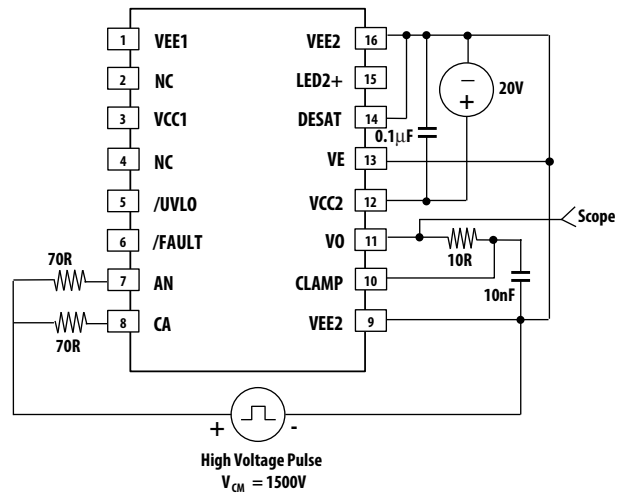

Figure 12 CMR Vo Low Test Circuit



Description of Under Voltage Lock Out

Insufficient gate voltage to MOSFET can increase turn on resistance of MOSFET, resulting in large power loss and MOSFET damage due to high heat dissipation. ACPL-335J monitors the output power supply constantly. When output power supply is lower than under voltage lockout (UVLO) threshold gate driver output will shut off to protect MOSFET from low voltage bias. During power up, the UVLO feature forces the gate driver output to low to prevent unwanted turn-on at lower voltage.

Description of Operation during Over Current Condition

1. DESAT terminal monitors MOSFET's Drain-Source voltage, V_{DS} .
2. When the voltage on the DESAT terminal exceeds Desat sensing threshold, the output shuts down immediately.
3. FAULT output goes low, notifying the microcontroller of the fault condition.
4. Microcontroller takes appropriate action.
5. When $t_{DESAT(MUTE)}$ expires LED input need to be kept low for $t_{DESAT(RESET)}$ before fault condition is cleared. FAULT status will return to high and CLAMP output will return to Hi-Z state.
6. Output (V_O) starts to respond to LED input after fault condition is cleared.

Figure 17 Circuit Behaviors during Over Current Event

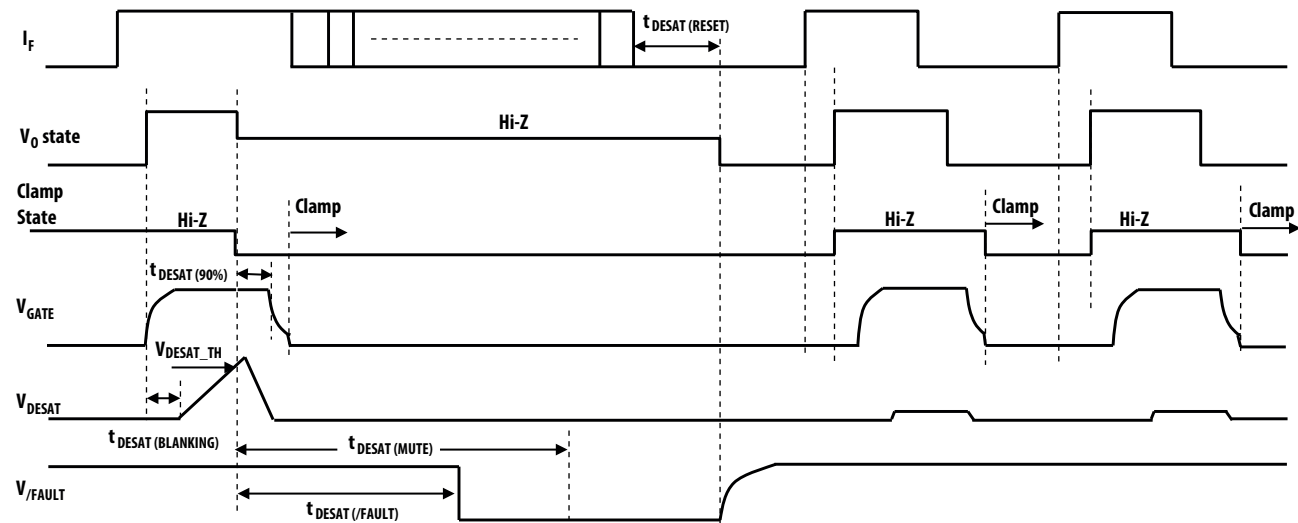

Recommended LED Drive Circuits

There will be common mode noise whenever there is a difference in the ground level of the optocoupler's input control circuitry and that of the output control circuitry. Figure 18 and Figure 19 show the recommended LED drive circuits that use logic gate (CMOS buffer) for high common mode rejection (CMR) performance of the optocoupler gate driver. Split limiting resistors are used to balance the impedance at both anode and cathode of the input LED for high common mode noise rejection. The output impedance of the CMOS buffer (shown as R_O in Figure 18 and Figure 19) has to be included in the calculation for LED drive current.

On the other hand, Figure 20 shows the recommended LED drive circuits that use a single transistor. During the LED off state, MOSFET or transistor will shunt current, which results in greater power consumption. It is not recommended to have open drain and open collector drive circuits, as shown in Figure 21. This is because during the off state of the MOSFET/transistor, the cathode of the input LED sees high impedance and becomes sensitive to common mode switching noise.

Figure 18 Recommended Non-inverting Drive Circuit

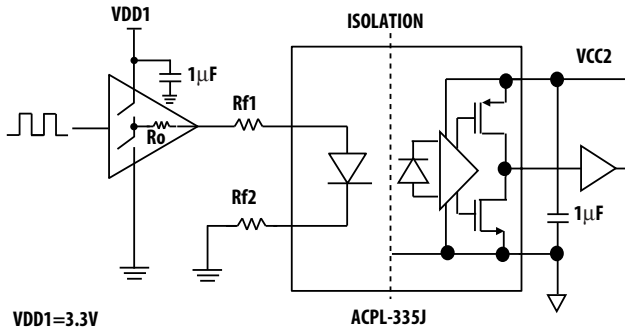

VDD1=3.3V
 $Rf2 = Rf1 + Ro$
 Recommended $Ro + Rf1 + Rf2 = 140\Omega$

Figure 19 Recommended Single Transistor Drive Circuit

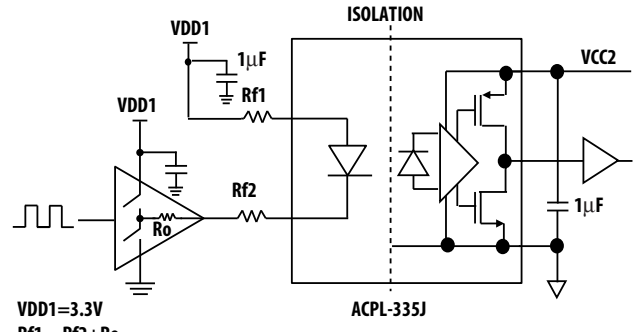

VDD1=3.3V
 $Rf1 = Rf2 + Ro$
 Recommended $Ro + Rf1 + Rf2 = 140\Omega$

Figure 20 Recommended Inverting Drive Circuit

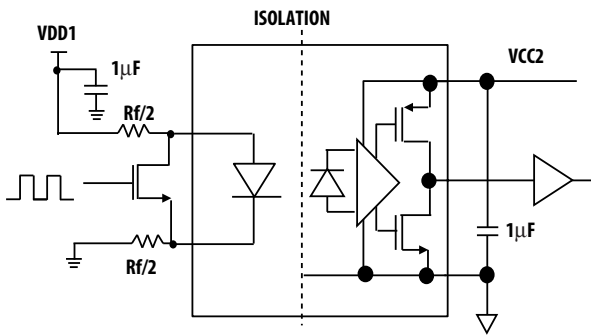

VDD1=3.3V
 Recommended $Rf = 140\Omega$

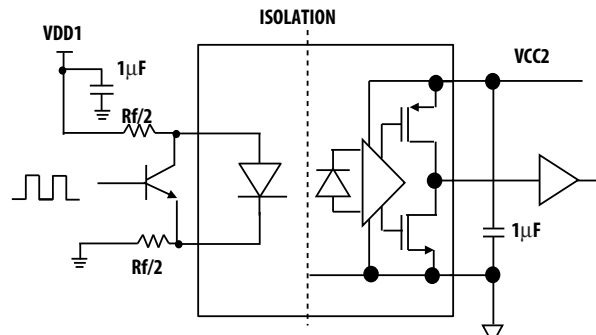

VDD1=3.3V
 Recommended $Rf = 140\Omega$

Figure 21 Not Recommended – Open Drain/Open Collector Drive Circuit

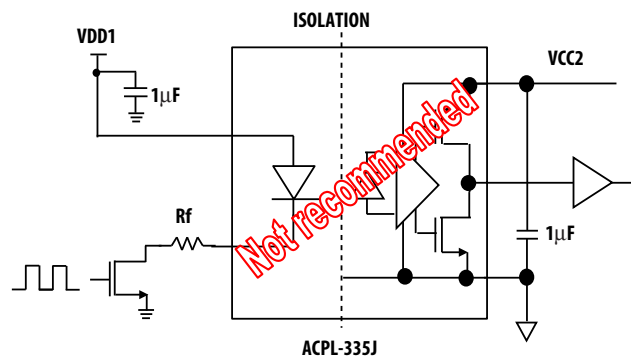
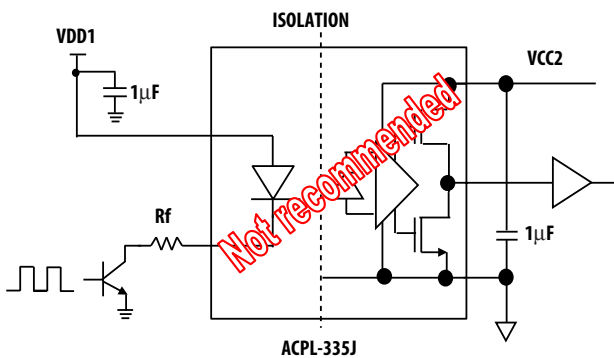

Drive Power

If a CMOS buffer is used to drive the LED, it is recommended that user connect the CMOS buffer at the LED cathode. This is because the sinking capability of the NMOS is usually greater than the driving capability of the PMOS in a CMOS buffer.

Drive Logic

The designer can configure LED drive circuits for non-inverting and inverting logic as recommended in [Figure 18](#) and [Figure 19](#). For the inverting and non-inverting logic to work, the external power supply V_{DD1} must be connected to the CMOS buffer. If the V_{DD1} supply is lost, the LED will be permanently off and output will be low.

Bypass and Reservoir Capacitors

Supply bypass capacitors are necessary at the input buffer and ACPL-335J output supply pins. A ceramic capacitor with the value of $1\ \mu\text{F}$ is recommended at the input buffer to provide high frequency bypass, which also helps to improve CMR performance. At the output supply pins, it is recommended to use a $1\text{-}\mu\text{F}$ low ESR and low ESL capacitor across $V_{CC2} - V_E$, $V_E - V_{EE2}$ and $V_{CC2} - V_{EE2}$ pins. These capacitors are used to supply instant driving current to MOSFET at V_{OUT} during switching.

Anti-Cross Conduction Drive

One of the many benefits of using ACPL-335J is the ease of implementing anti-cross conduction drive between the high side and the low side gate drivers to prevent a shoot-through event. This safety interlock drive can be realized by interlocking the output of buffer U3 and U4 to both the high and the low side gate drivers, as shown in [Figure 22](#). Due to the difference in propagation delay between optocouplers, however, a certain amount of dead time has to be added to ensure sufficient dead time at the MOSFET gate. For more details, see [Dead Time Distortion and Propagation Delay](#).

Figure 22 Typical High-speed MOSFET Gate Drive Circuit

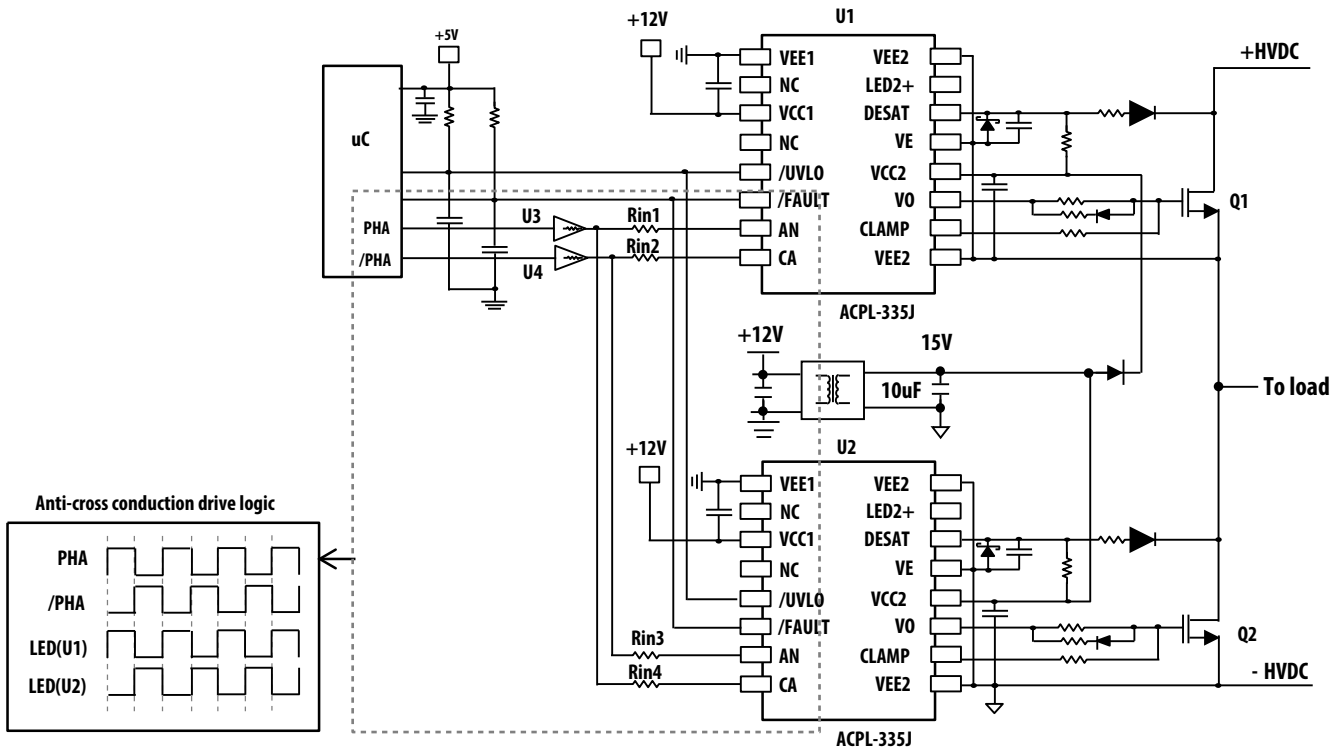

Dead Time Distortion and Propagation Delay

Dead time is the period of time during which both high side and low side power transistors (shown as Q1 and Q2 in Figure 22) are off. Originally, the system is required to design in some amount of dead time to compensate for the turnoff delay needed for the MOSFET to discharge the input capacitance after the gate is switched off. In this application note, this amount of dead time is called system original dead time. When an optocoupler is used, the designer has to consider the effect of the optocoupler's dead time distortion (DTD) toward system original dead time. The optocoupler's negative DTD decreases system original dead time; on the other hand, the optocoupler's positive DTD increases system original dead time. Therefore, the designer must add extra dead time to system original dead time to compensate for the optocoupler's negative DTD. Figure 23 and Figure 24 illustrate the effect of the optocoupler's DTD to system original dead time.

Dead Time and Propagation Delay Waveforms

Figure 23 Negative DTD Reduces Original DT

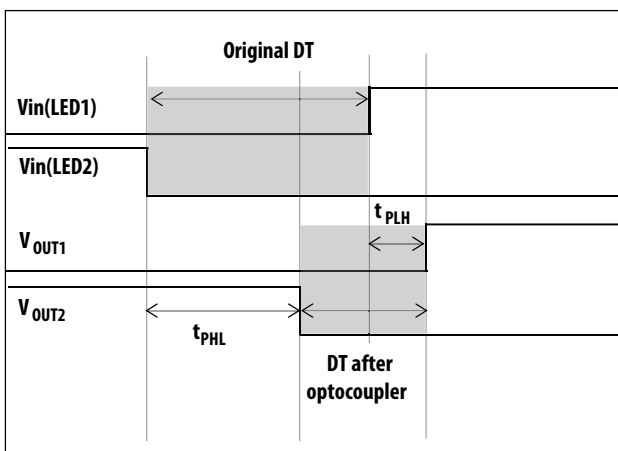
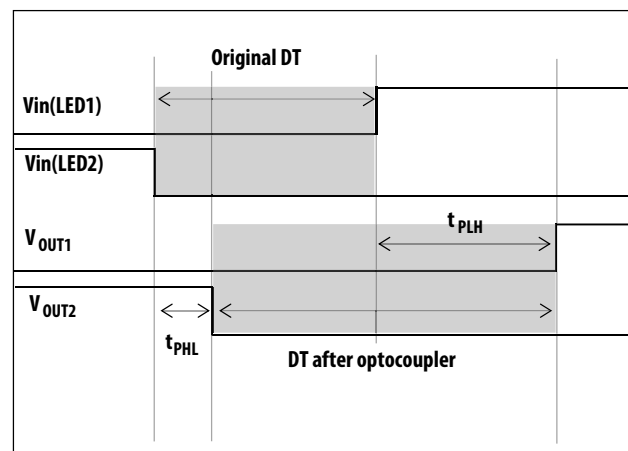

Figure 24 Positive DTD Increases Original DT



Here is an example of total dead time calculation for a typical optocoupler drive circuit for MOSFET.

Total dead time required

= System original dead time + |optocoupler's negative DTD|

= System original dead time + |100 ns|

where system original dead time = MOSFET turn-off delay

NOTE The propagation delays used to calculate dead time distortion (DTD) are taken at equal temperatures and test conditions as the optocouplers used under consideration are typically mounted in close proximity to each other and are switching same type of MOSFETs.