

# ACPL-339J

## Dual-Output Gate Drive Optocoupler Interface with Integrated (V<sub>CE</sub>) DESAT Detection, FAULT and UVLO Status Feedback



### Data Sheet

#### Description

The ACPL-339J is an advanced 1.0 A dual-output, easy-to-use, intelligent IGBT and Power MOSFET gate drive optocoupler interface. Uniquely designed to support MOSFET buffer of various current ratings, the ACPL-339J makes it easier for system engineers to support different system power ratings using one hardware platform by interchanging the MOSFET buffers and power IGBT/MOSFET switches. These changes can be made without redesigning the critical circuit isolation and short-circuit protection. This concept maximizes gate drive design scalability for motor control and power conversion applications ranging from low to high power ratings.

The ACPL-339J contains a AlGaAs LED. The LED is optically coupled to an integrated circuit with two power output stages with active timing control to prevent cross conduction at external MOSFET buffer. It is also integrated with features such as V<sub>CE</sub> detection, under voltage lockout (UVLO), "soft" IGBT turn-off, and isolated open collector fault feedback to provide maximum design flexibility and circuit protection. The ACPL-339J has an insulation voltage of V<sub>IORM</sub> = 1414 V<sub>peak</sub> in IEC/EN/DIN EN 60747-5-5.

#### Functional Diagram

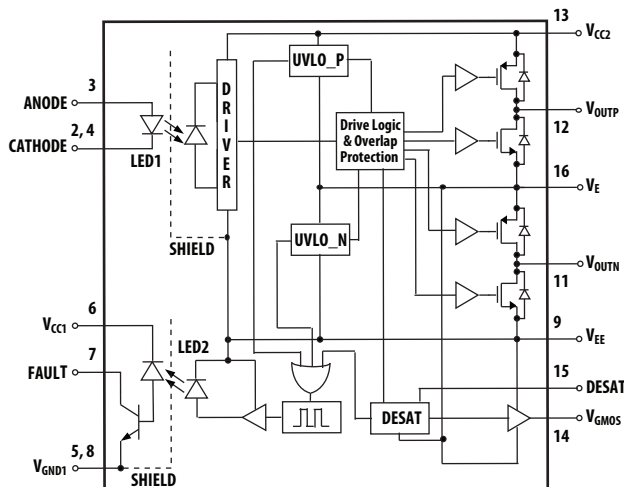

#### Features

- Dual output drive for external NMOS and PMOS buffer
- 1.0 A minimum peak output current
- Active timing control to prevent cross conduction in MOSFET buffer
- IGBT desaturation detection
- Isolated DESAT and UVLO fault feedback
- Configurable "Soft" shutdown during fault
- Under Voltage Lock-Out Protection (UVLO) with Hysteresis for positive and negative power supply
- 300 ns maximum propagation delay over temperature range.
- 6.0 mA to 10.0 mA Low LED input current
- 25 kV/μs Minimum Common Mode Rejection (CMR) at V<sub>CM</sub> = 1500 V
- Wide Operating V<sub>CC</sub> Range: 15 V to 30 V
- Industrial temperature range: -40° C to 105° C
- SO-16 package
- Safety Approval Pending
  - UL Recognized 5000 V<sub>RMS</sub> for 1 min.
  - CSA
  - IEC/EN/DIN EN 60747-5-5 V<sub>IORM</sub> = 1414 V<sub>peak</sub>

#### Applications

- IGBT/Power MOSFET gate drive Interface
- AC and brushless DC motor drives
- Renewable energy inverters
- Industrial Inverters
- Switching power supplies

**CAUTION:** It is advised that normal static precautions be taken in handling and assembly of this component to prevent damage and/or degradation which may be induced by ESD.

## Pin Description

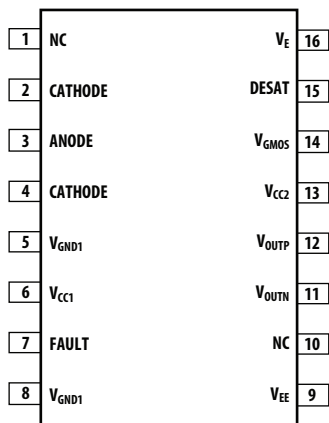

Pin	Symbol	Description
1	NC	No connection
2	CATHODE	Cathode
3	ANODE	Anode
4	CATHODE	Cathode
5	V <sub>GND1</sub>	Input ground
6	V <sub>CC1</sub>	Positive input supply voltage (3.3 V ± 5%, 5 V ± 5%)
7	FAULT	Fault output. FAULT changes from logic low to high output: a) after T <sub>BLANK</sub> (set by C <sub>BLANK</sub> and the internal current source of 250 μA), once the voltage on the DESAT pin exceeding an internal reference voltage of 8 V (reference to V <sub>E</sub> ) b) UVLO condition
8	V <sub>GND1</sub>	Input ground
9	V <sub>EE</sub>	Output supply voltage
10	NC	No connection
11	V <sub>OUTN</sub>	Low side voltage output
12	V <sub>OUTP</sub>	High side voltage output
13	V <sub>CC2</sub>	Positive output supply voltage
14	V <sub>GMOS</sub>	V <sub>GMOS</sub> will switch from V <sub>EE</sub> to V <sub>E</sub> after DESAT is activated
15	DESAT	Desaturation voltage input. When the voltage on DESAT exceeds an internal reference voltage of 8 V while the IGBT is on, FAULT and V <sub>GMOS</sub> outputs are changed from logic low to high state.
16	V <sub>E</sub>	Common (IGBT emitter) output supply voltage

## Ordering Information

ACPL-339J is UL Recognized with 5000 Vrms for 1 minute per UL1577.

Part number	Option		Package	Surface Mount	Tape & Reel	IEC/EN/DIN EN 60747-5-5	Quantity
	RoHS Compliant						
ACPL-339J	-000E		SO-16	X		X	45 per tube
	-500E			X	X		

To order, choose a part number from the part number column and combine with the desired option from the option column to form an order entry.

### Example 1:

ACPL-339J-500E to order product of SO-16 Surface Mount package in Tape and Reel packaging with IEC/EN/DIN EN 60747-5-5 Safety Approval in RoHS compliant.

Option datasheets are available. Contact your Avago sales representative or authorized distributor for information.

## Package Outline Drawings

### ACPL-339J 16-Lead Surface Mount Package

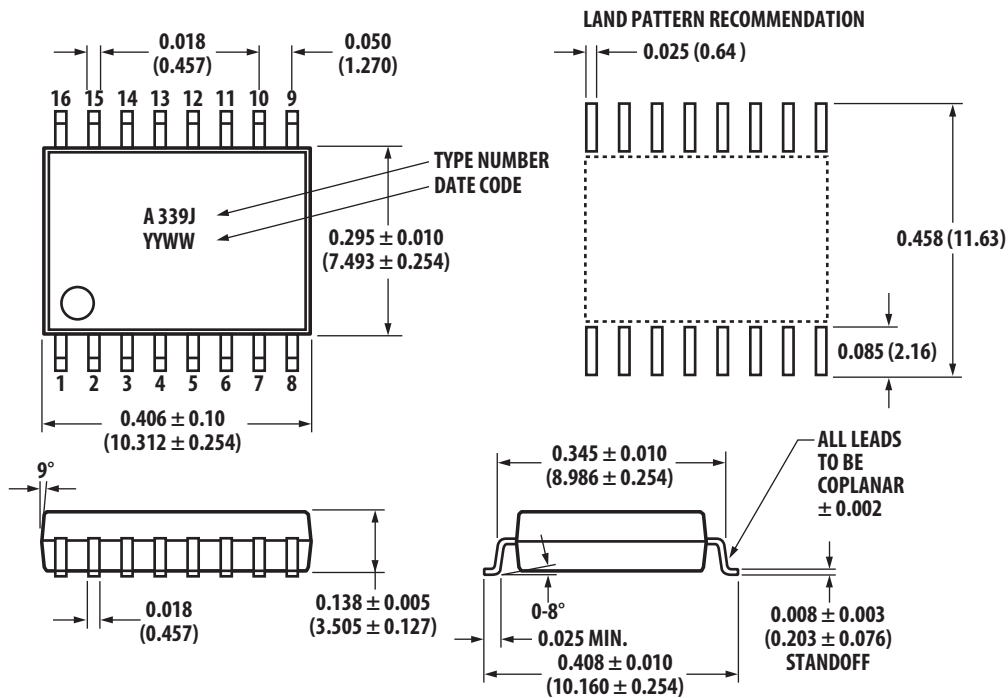

Dimensions in inches (millimeters)

Notes: Initial and continued variation in the color of the ACPL-339J's white mold compound is normal and does not affect device performance or reliability.

Floating Lead Protrusion is 0.25 mm (10 mils) max.

### Recommended Pb-Free IR Profile

Recommended reflow condition as per JEDEC Standard, J-STD-020 (latest revision). Non-Halide Flux should be used.

### Regulatory Information

The ACPL-339J is pending approval by the following organizations:

#### IEC/EN/DIN EN 60747-5-5

Maximum working insulation voltage  $V_{IORM} = 1414 V_{PEAK}$

#### UL

Approval under UL 1577, component recognition program up to  $V_{ISO} = 5000 V_{RMS}$ . File E55361.

#### CSA

Approval under CSA Component Acceptance Notice #5, File CA 88324.

**Table 1. IEC/EN/DIN EN 60747-5-5 Insulation Characteristics\***

Description	Symbol	Characteristic	Unit
Installation classification per DIN VDE 0110/39, Table 1			
for rated mains voltage $\leq 150 V_{rms}$		I – IV	
for rated mains voltage $\leq 300 V_{rms}$		I – IV	
for rated mains voltage $\leq 600 V_{rms}$		I – IV	
for rated mains voltage $\leq 1000 V_{rms}$		I – III	
Climatic Classification		40/105/21	
Pollution Degree (DIN VDE 0110/39)		2	
Maximum Working Insulation Voltage	$V_{IORM}$	1414	$V_{peak}$
Input to Output Test Voltage, Method b**	$V_{PR}$	2652	$V_{peak}$
$V_{IORM} \times 1.875 = V_{PR}$ , 100% Production Test with $t_m = 1$ sec, Partial discharge $< 5$ pC			
Input to Output Test Voltage, Method a**	$V_{PR}$	2262	$V_{peak}$
$V_{IORM} \times 1.6 = V_{PR}$ , Type and Sample Test, $t_m = 10$ sec, Partial discharge $< 5$ pC			
Highest Allowable Overvoltage (Transient Overvoltage $t_{ini} = 60$ sec)	$V_{IOTM}$	8000	$V_{peak}$
Safety-limiting values – maximum values allowed in the event of a failure.			
Case Temperature	$T_S$	175	$^{\circ}C$
Input Current	$I_{S, INPUT}$	400	mA
Output Power	$P_{S, OUTPUT}$	1200	mW
Insulation Resistance at $T_S$ , $V_{IO} = 500$ V	$R_S$	$>10^9$	W

\* Isolation characteristics are guaranteed only within the safety maximum ratings which must be ensured by protective circuits in application. Surface mount classification is class A in accordance with CECC00802.

\*\* Refer to the optocoupler section of the Isolation and Control Components Designer's Catalog, under Product Safety Regulations section IEC/EN/DIN EN 60747-5-5, for a detailed description of Method a and Method b partial discharge test profiles.

**Table 2. Insulation and Safety Related Specifications**

Parameter	Symbol	ACPL-339J	Units	Conditions
Minimum External Air Gap (Clearance)	L(101)	8.3	mm	Measured from input terminals to output terminals, shortest distance through air.
Minimum External Tracking (Creepage)	L(102)	8.3	mm	Measured from input terminals to output terminals, shortest distance path along body.
Minimum Internal Plastic Gap (Internal Clearance)		0.5	mm	Through insulation distance conductor to conductor, usually the straight line distance thickness between the emitter and detector.
Tracking Resistance (Comparative Tracking Index)	CTI	$>175$	V	DIN IEC 112/VDE 0303 Part 1
Isolation Group		IIIa		Material Group (DIN VDE 0110, 1/89, Table 1)

**Table 3. Absolute Maximum Ratings**

Parameter	Symbol	Min.	Max.	Units	Note
Storage Temperature	$T_S$	-55	125	°C	
Operating Temperature	$T_A$	-40	105	°C	
Output IC Junction Temperature	$T_J$		125	°C	
Average Input Current	$I_{F(AVG)}$		25	mA	1
Peak Transient Input Current ( $< 1 \mu s$ pulse width, 300 pps)	$I_{F(TRAN)}$		1.0	A	
Reverse Input Voltage	$V_R$		5	V	
“High” Peak Output Current	$I_{OH(PEAK)}$		5.5	A	2
“Low” Peak Output Current	$I_{OL(PEAK)}$		5.5	A	2
Positive Input Supply Voltage	$V_{CC1}$	0	7	V	
FAULT Output Current	$I_{FAULT}$		8	mA	
FAULT Pin Voltage	$V_{FAULT}$	-0.5	$V_{CC1}$	V	
Total Output Supply Voltage	$(V_{CC2} - V_{EE})$	0	35	V	
Negative Output Supply Voltage	$(V_E - V_{EE})$	0	17	V	
Positive Output Supply Voltage	$(V_{CC2} - V_E)$	0	$35 - (V_E - V_{EE})$	V	
Input Current (Rise/Fall Time)	$t_{r(IN)}/t_{f(IN)}$		500	ns	
High Side Output Voltage	$V_{OUTP(PEAK)}$	$V_E - 0.5$	$V_{CC2} + 0.5$	V	
Low Side Output Voltage	$V_{OUTN(PEAK)}$	$V_{EE} - 0.5$	$V_E + 0.5$	V	
DESAT Voltage	$V_{DESAT}$	$V_E - 0.5$	$V_{CC2} + 0.5$	V	
$V_{GMOS}$ Voltage	$V_{GMOS}$	$V_{EE} - 0.5$	$V_E + 0.5$	V	
Output IC Power Dissipation	$P_O$		600	mW	3
Input LED Power Dissipation	$P_I$		150	mW	4

Notes:

1. Derate linearly above 70° C free-air temperature at a rate of 0.3 mA/°C.
2. Maximum pulse width = 10  $\mu s$
3. Derate linearly above 95° C free-air temperature at a rate of 20 mW/°C.
4. Derate linearly above 95° C free-air temperature at a rate of 4 mW/°C. The maximum LED junction temperature should not exceed 125° C.

**Table 4. Recommended Operating Conditions**

Parameter	Symbol	Min.	Max.	Units	Note
Operating Temperature	$T_A$	-40	105	°C	
Positive Input Supply Voltage	$V_{CC1}$	3	5.5	V	
Total Output Supply Voltage	$(V_{CC2} - V_{EE})$	21	30	V	
Negative Output Supply Voltage	$(V_E - V_{EE})$	6	15	V	
Positive Output Supply Voltage	$(V_{CC2} - V_E)$	15	$30 - (V_E - V_{EE})$	V	
Input Current (ON)	$I_{F(ON)}$	6	10	mA	
Input Voltage (OFF)	$V_{F(OFF)}$	-3.6	0.8	V	

**Table 5. Electrical Specifications (DC)**

Unless otherwise noted, all typical values at  $T_A = 25^\circ\text{C}$ ,  $V_{CC1} = 3.3\text{ V}$  or  $5\text{ V}$ ,  $V_{CC2} - V_E = 15\text{ V}$ ,  $V_E - V_{EE} = 8\text{ V}$ ; all Minimum/Maximum specifications are at Recommended Operating Conditions.

Parameter	Symbol	Min.	Typ.	Max.	Units	Test Conditions	Fig.	Note
$V_{OUTP}$ High Level Output Current	$I_{OUTPH}$	-1			A	$V_{CC2} - V_{OUTP} \leq 15\text{ V}$	3	1
$V_{OUTP}$ Low Level Output Current	$I_{OUTPL}$	1			A	$V_{OUTP} - V_E \leq 15\text{ V}$	4	1
$V_{OUTN}$ High Level Output Current	$I_{OUTNH}$	-1			A	$V_E - V_{OUTN} \leq 8\text{ V}$	3	1
$V_{OUTN}$ Low Level Output Current	$I_{OUTNL}$	1			A	$V_{OUTN} - V_{EE} \leq 8\text{ V}$	4	1
$V_{OUTP}$ High Level Output $R_{DS(on)}$	$R_{OUTPH}$		3.5	7	$\Omega$	$I_{OUTP} = -1\text{ A}$ , $V_F = 0\text{ V}$	3, 5	1
$V_{OUTP}$ Low Level Output $R_{DS(on)}$	$R_{OUTPL}$		1.5	4	$\Omega$	$I_{OUTP} = 1\text{ A}$ , $I_F = 8\text{ mA}$	4, 6	1
$V_{OUTN}$ High Level Output $R_{DS(on)}$	$R_{OUTNH}$		3.5	7	$\Omega$	$I_{OUTN} = -1\text{ A}$ , $V_F = 0\text{ V}$	3, 5	1
$V_{OUTN}$ Low Level Output $R_{DS(on)}$	$R_{OUTNL}$		1.5	4	$\Omega$	$I_{OUTN} = 1\text{ A}$ , $I_F = 8\text{ mA}$	4, 6	1
$V_{OUTP}$ High Level Output Voltage	$V_{OUTPH}$	$V_{CC2} - 0.60$	$V_{CC2} - 0.30$		V	$I_{OUTP} = -100\text{ mA}$ , $V_F = 0\text{ V}$	1	2, 4, 5
$V_{OUTP}$ Low Level Output Voltage	$V_{OUTPL}$		$V_E + 0.14$	$V_E + 0.50$	V	$I_{OUTP} = 100\text{ mA}$ , $I_F = 8\text{ mA}$	2	
$V_{OUTN}$ High Level Output Voltage	$V_{OUTNH}$	$V_E - 0.60$	$V_E - 0.30$		V	$I_{OUTN} = -100\text{ mA}$ , $V_F = 0\text{ V}$	1	3, 4, 5
$V_{OUTN}$ Low Level Output Voltage	$V_{OUTNL}$		$V_{EE} + 0.12$	$V_{EE} + 0.60$	V	$I_{OUTN} = 100\text{ mA}$ , $I_F = 8\text{ mA}$	2	
$V_{GMOS}$ High Level Output Current	$I_{OUTGH}$	-80			mA	$V_E - V_{GMOS} \leq 8\text{ V}$ , $I_F = 8\text{ mA}$ , $DESAT = \text{Open}$		
$V_{GMOS}$ Low Level Output Current	$I_{OUTGL}$	80			mA	$V_{GMOS} - V_{EE} \leq 8\text{ V}$ , $V_F = 0\text{ V}$ , $DESAT = \text{Open}$		
$V_{GMOS}$ High Level Output $R_{DS(on)}$	$R_{OUTGH}$		22	30	$\Omega$	$I_{OUTG} = -80\text{ mA}$ , $I_F = 8\text{ mA}$	7	
$V_{GMOS}$ Low Level Output $R_{DS(on)}$	$R_{OUTGL}$		6	10	$\Omega$	$I_{OUTN} = 80\text{ mA}$ , $V_F = 0\text{ V}$ , $DESAT = \text{Open}$	8	
$V_{GMOS}$ High Level Output Voltage	$V_{OUTGH}$		$V_E$		V	$I_{OUTG} = 0\text{ mA}$ , $I_F = 8\text{ mA}$ , $DESAT = \text{Open}$		
$V_{GMOS}$ Low Level Output Voltage	$V_{OUTGL}$		$V_{EE}$		V	$I_{OUTN} = 0\text{ mA}$ , $V_F = 0\text{ V}$ , $DESAT = \text{Open}$		
High Level Output Supply Current ( $V_{CC2}$ )	$I_{CC2H}$		8.5	12	mA	$V_F = 0\text{ V}$ , No Load	9, 10	
Low Level Output Supply Current ( $V_{CC2}$ )	$I_{CC2L}$		8.5	12	mA	$I_F = 8\text{ mA}$ , No Load,	9, 10	
High Level Output Supply Current ( $V_{EE}$ )	$I_{EEH}$		8	11	mA	$V_F = 0\text{ V}$ , No Load	11, 12	
Low Level Output Supply Current ( $V_{EE}$ )	$I_{EEL}$		8	11	mA	$I_F = 8\text{ mA}$ , No Load	11, 12	
Threshold Input Current Low to High	$I_{FLH}$		1.3	5	mA	No Load, $V_{OUTP} - V_E < 5\text{ V}$ , $V_{OUTN} - V_{EE} < 1\text{ V}$	13, 14	
Threshold Input Voltage High to Low	$V_{FHL}$	0.8			V	No Load, $V_{OUTP} - V_E > 5\text{ V}$ , $V_{OUTN} - V_{EE} > 1\text{ V}$		

**Table 5. Electrical Specifications (DC)** (continued)

Unless otherwise noted, all typical values at  $T_A = 25^\circ\text{C}$ ,  $V_{CC1} = 3.3\text{ V}$  or  $5\text{ V}$ ,  $V_{CC2} - V_E = 15\text{ V}$ ,  $V_E - V_{EE} = 8\text{ V}$ ; all Minimum/Maximum specifications are at Recommended Operating Conditions.

Parameter	Symbol	Min.	Typ.	Max.	Units	Test Conditions	Fig.	Note
Input Forward Voltage	$V_F$	1.2	1.55	1.95	V	$I_F = 8\text{ mA}$		
Temperature Coefficient of Input Forward Voltage	$\Delta V_F / \Delta T_A$		-1.7		mV/ $^\circ\text{C}$	$I_F = 8\text{ mA}$		
Input Reverse Breakdown Voltage	$BV_R$	5			V	$I_R = 100\text{ mA}$		
Input Capacitance	$C_{IN}$		70		pF	$f = 1\text{ MHz}$ , $V_F = 0\text{ V}$		
UVLO_P Threshold, $V_{CC2} - V_E$	$V_{UVLOP+}$	12	13	14	V	$I_F = 8\text{ mA}$ , $V_{OUTP} - V_E < 5\text{ V}$	31	2, 5, 6
	$V_{UVLOP-}$	11	12	13	V	$I_F = 8\text{ mA}$ , $V_{OUTP} - V_E > 5\text{ V}$	31	3, 5, 7
UVLO_P Hysteresis, $V_{CC2} - V_E$	$V_{UVLOP+} - V_{UVLOP-}$		1		V			
UVLO_N Threshold, $V_E - V_{EE}$	$V_{UVLON+}$	4.8	5.4	6	V	$I_F = 8\text{ mA}$ , $V_{OUTN} - V_{EE} < 1\text{ V}$	31	2, 5, 8
	$V_{UVLON-}$	4.7	5	5.7	V	$I_F = 8\text{ mA}$ , $V_{OUTN} - V_{EE} > 1\text{ V}$	31	3, 5, 9
UVLO_N Hysteresis, $V_E - V_{EE}$	$V_{UVLON+} - V_{UVLON-}$		0.3		V			
DESAT Threshold	$V_{DESAT}$	7.5	8	9	V	$V_{CC2} - V_E > V_{UVLOP-}$ and $V_E - V_{EE} > V_{UVLON-}$	15	5
Blanking Capacitor Charging Current	$I_{CHG}$	0.15	0.25	0.36	mA	$V_{DESAT} = 2\text{ V}$	16	5, 10
DESAT Low Voltage when Blanking Capacitor Discharge	$V_{DSCHG}$		1.1	3	V	$I_{DSCHG} = 10\text{ mA}$		5, 10
FAULT Logic Low Output Voltage	$V_{FAULTL}$		0.10	0.25	V	$V_{DESAT} = 0\text{ V}$ , $R_F = 10\text{ k}\Omega$ , $C_F = 1\text{ nF}$ , $V_{CC1} = 5\text{ V}$ or $3.3\text{ V}$		
FAULT Logic High Output Voltage	$V_{FAULTH}$		$V_{CC1}$		V	DESAT = Open, $R_F = 10\text{ k}\Omega$ , $C_F = 1\text{ nF}$ , $V_{CC1} = 5\text{ V}$ or $3.3\text{ V}$		
FAULT Logic Low Output Current	$I_{FAULTL}$		0.25		mA	$V_{FAULT} = 0.15\text{ V}$ , $V_{CC1} = 5\text{ V}$ or $3.3\text{ V}$		
FAULT Logic High Output Current	$I_{FAULTH}$		0.2	1	$\mu\text{A}$	$V_{FAULT} = V_{CC1} = 5\text{ V}$ or $3.3\text{ V}$		

## Notes:

- Output is sourced at  $-1.0\text{ A}$  /  $1.0\text{ A}$  with a maximum pulse width =  $10\text{ }\mu\text{s}$ .
- $15\text{ V}$  is the recommended minimum operating positive supply voltage ( $V_{CC2} - V_E$ ) to ensure adequate margin in excess of the maximum  $V_{UVLOP+}$  threshold of  $13.5\text{ V}$ . For High Level Output Voltage testing,  $V_{OUTP}$  is measured with a  $50\text{ }\mu\text{s}$  pulse load current. When driving capacitive loads,  $V_{OUTP}$  will approach  $V_{CC}$  as  $I_{OUTPH}$  approaches zero units.
- $6.6\text{ V}$  is the recommended minimum operating positive supply voltage ( $V_E - V_{EE}$ ) to ensure adequate margin in excess of the maximum  $V_{UVLON+}$  threshold of  $5.6\text{ V}$ . For High Level Output Voltage testing,  $V_{OUTN}$  is measured with a  $50\text{ }\mu\text{s}$  pulse load current. When driving capacitive loads,  $V_{OUTN}$  will approach  $V_E$  as  $I_{OUTNH}$  approaches zero units.
- Maximum pulse width =  $1.0\text{ ms}$ .
- Once  $V_{OUTP}$  is allowed to go low ( $V_{CC2} - V_E > V_{UVLOP+}$ ) and  $V_{OUTN}$  is allowed to go high ( $V_E - V_{EE} > V_{UVLON+}$ ), the DESAT detection feature of the ACPL-339J will be the primary source of IGBT protection. UVLO is needed to ensure DESAT is functional. Once  $V_{CC2} - V_E > V_{UVLOP+}$  and  $V_E - V_{EE} > V_{UVLON+}$ , DESAT will remain functional until  $V_{CC2} - V_E < V_{UVLOP-}$  or  $V_E - V_{EE} < V_{UVLON-}$ . Thus, the DESAT detection and UVLO features of the ACPL-339J work in conjunction to ensure constant IGBT protection.
- This is the "increasing" (i.e. turn-on or "positive going" direction) of  $V_{CC2} - V_E$ .
- This is the "decreasing" (i.e. turn-off or "negative going" direction) of  $V_{CC2} - V_E$ .
- This is the "increasing" (i.e. turn-on or "positive going" direction) of  $V_{EE} - V_E$ .
- This is the "decreasing" (i.e. turn-off or "negative going" direction) of  $V_{EE} - V_E$ .
- See the DESAT fault detection blanking time section in the applications notes at the end of this data sheet for further details.

**Table 6. Switching Specifications (AC)**

Unless otherwise noted, all typical values at  $T_A = 25^\circ\text{C}$ ,  $V_{CC1} = 3.3\text{ V}$  or  $5\text{ V}$ , and  $V_{CC2} - V_E = 15\text{ V}$ ,  $V_E - V_{EE} = 8\text{ V}$ ; all Minimum/Maximum specifications are at Recommended Operating Conditions.

Parameter	Symbol	Min.	Typ.	Max.	Units	Test Conditions	Fig.	Note
Propagation Delay Time to High Output Level	$t_{PLH}$	100	180	300	ns	$C_P = C_N = 4\text{ nF}$ , $f = 20\text{ kHz}$ ,	17, 18, 30	1
Propagation Delay Time to Low Output Level	$t_{PHL}$	100	150	300	ns	Duty Cycle = 50%, $I_F = 6\text{ mA}$ to $10\text{ mA}$	17, 18, 30	1
Pulse Width Distortion	PWD	150	25	150	ns			2
Propagation Delay Difference Between Any Two Parts	PDD ( $t_{PLH} - t_{PHL}$ )	-200		200	ns		36, 37	3
Propagation Delay Skew	$t_{PSK}$			170	ns			7
LED OFF to 90% of $V_{OUTP}$	$t_{DP}$	50	150	250	ns		17,18, 30	
LED ON to 10% of $V_{OUTN}$	$t_{DN}$	50	125	250	ns		17,18, 30	
Non-overlap Time Low to High	$t_{NLH}$		30		ns		25, 30	
Non-overlap Time High to Low	$t_{NHL}$		20		ns		25, 30	
10% to 90% Rise Time on $V_{OUTP}$	$t_{PR}$		40		ns	$C_P = C_N = 4\text{ nF}$ , $f = 20\text{ kHz}$ ,	30	
90% to 10% Fall Time on $V_{OUTP}$	$t_{PF}$		40		ns	Duty Cycle = 50%, $I_F = 8\text{ mA}$	30	
10% to 90% Rise Time on $V_{OUTN}$	$t_{NR}$		40		ns		30	
90% to 10% Fall Time on $V_{OUTN}$	$t_{NF}$		30		ns		30	
Delay time from DESAT threshold to 50% of High $V_{GMOS}$	$t_1$		250	500	ns	$C_P = C_N = 4\text{ nF}$ , $C_G = 1\text{ nF}$ , $f = 250\text{ Hz}$ , Duty Cycle = 50%, $I_F = 8\text{ mA}$	19, 22, 28, 29	
Delay time from DESAT threshold to 50% of High $V_{OUTP}$	$t_2$		250	500	ns		19, 28, 29	
Delay time from DESAT threshold to 50% of High FAULT	$t_3$		8.5	11	$\mu\text{s}$	$R_F = 10\text{ k}\Omega$ , $C_F = 1\text{ nF}$ , $V_{CC1} = 3.3\text{ V}$ or $5\text{ V}$ , $f = 250\text{ Hz}$ , Duty Cycle = 50%, $I_F = 8\text{ mA}$	20, 28, 29	
Delay from 50% of $V_{GMOS}$ to 50% of $V_{OUTN}$	$t_4$		11		ns	$C_P = C_N = 4\text{ nF}$ , $C_G = 1\text{ nF}$ , $f = 250\text{ Hz}$ , Duty Cycle = 50%, $I_F = 8\text{ mA}$	21, 23, 28, 29	
Mute time	$t_{MUTE}$	0.75	1	1.5	ms	$f = 700\text{ Hz}$ , Duty Cycle = 50%, $I_F = 8\text{ mA}$	24, 28, 29	4
Output High Level Common Mode Transient Immunity	$ CM_H $	25	35		$\text{kV}/\mu\text{s}$	$T_A = 25^\circ\text{C}$ , $V_{CM} = 1500\text{ V}$ , $V_{CC1} = 5\text{ V}$ , $C_F = 1\text{ nF}$ , $R_F = 10\text{ k}\Omega$ , $I_F = 8\text{ mA}$ with split resistors		5
Output Low Level Common Mode Transient Immunity	$ CM_L $	25	35		$\text{kV}/\mu\text{s}$	$T_A = 25^\circ\text{C}$ , $V_{CM} = 1500\text{ V}$ , $V_{CC1} = 5\text{ V}$ , $C_F = 1\text{ nF}$ , $R_F = 10\text{ k}\Omega$ , $V_F = 0\text{ V}$		6

## Notes:

- This load condition approximates the gate load of a 60V/5A MOSFET
- Pulse Width Distortion (PWD) is defined as  $|t_{PHL} - t_{PLH}|$  for any given unit.
- The difference between  $t_{PHL}$  and  $t_{PLH}$  between any two ACPL-339J parts under the same test conditions.
- Auto Reset: This is the minimum amount of time when  $V_{OUTP}$  will be asserted high,  $V_{OUTN}$  asserted low,  $V_{GMOS}$  asserted high and FAULT asserted high, after DESAT threshold is exceeded. See the Description of Operation (Auto Reset) topic in the application information section.
- Common mode transient immunity in the high state is the maximum tolerable  $dV_{CM}/dt$  of the common mode pulse,  $V_{CM}$ , to assure that the output will remain in the high state (i.e.,  $V_{OUTP} - V_E > 12\text{ V}$ ,  $V_{OUTN} - V_{EE} > 5\text{ V}$  or FAULT  $> 2\text{ V}$ ). A 1 nF and a 10 k $\Omega$  pull-up resistor is needed in fault detection mode.
- Common mode transient immunity in the low state is the maximum tolerable  $dV_{CM}/dt$  of the common mode pulse,  $V_{CM}$ , to assure that the output will remain in a low state (i.e.,  $V_{OUTP} - V_E < 1.0\text{ V}$ ,  $V_{OUTN} - V_{EE} < 1.0\text{ V}$  or FAULT  $< 0.8\text{ V}$ ).
- $t_{PSK}$  is equal to the worst-case difference in  $t_{PHL}$  or  $t_{PLH}$  that will be seen between units under the same test condition.



**Table 7. Package Characteristics**

Parameter	Symbol	Min.	Typ.	Max.	Units	Test Conditions	Fig.	Note
Input-Output Momentary Withstand Voltage	$V_{ISO}$	5000			$V_{rms}$	RH < 50%, $t = 1 \text{ min.}, T_A = 25^\circ \text{ C}$		1, 2
Input-Output Resistance	$R_{I-O}$		$> 10^9$		W	$V_{I-O} = 500 \text{ V}$		2
Input-Output Capacitance	$C_{I-O}$		1.3		pF	freq = 1 MHz		

Notes

- In accordance with UL1577, each optocoupler is proof tested by applying an insulation test voltage  $\geq 6000 V_{rms}$  for 1 second. This test is performed before the 100% production test for partial discharge (method b) shown in IEC/EN/DIN EN 60747-5-5 Insulation Characteristic Table, if applicable.
- Device considered a two-terminal device: pins 1 to 8 are shorted together and pins 9 to 16 are shorted together.

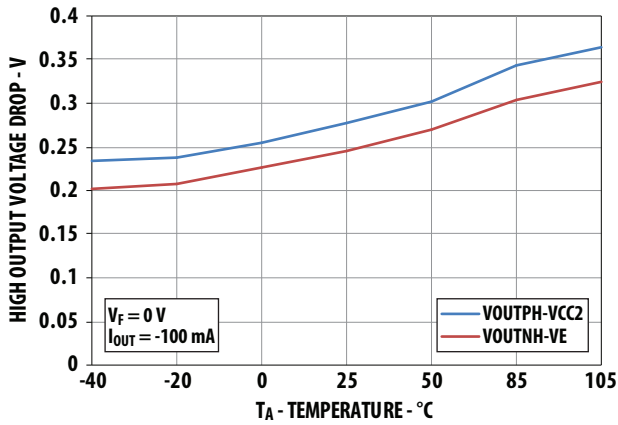

Figure 1.  $V_{OUTPH}/V_{OUTNH}$  vs. temperature

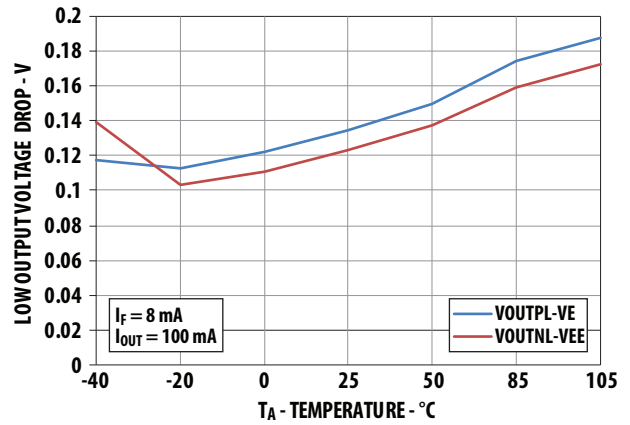

Figure 2.  $V_{OUTPL}/V_{OUTNL}$  vs. temperature

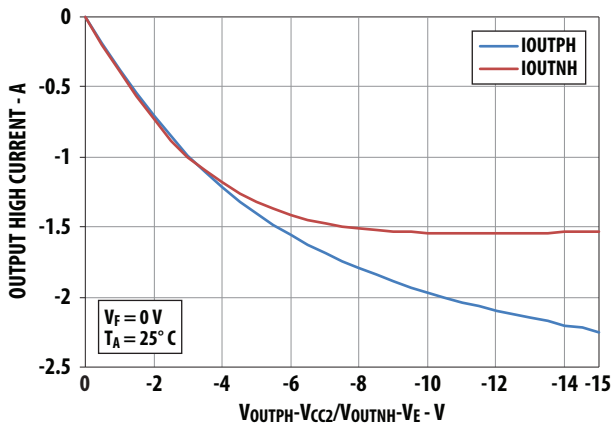

Figure 3.  $I_{OUTPH}/I_{OUTNH}$  vs.  $V_{OUTPH}/V_{OUTNH}$

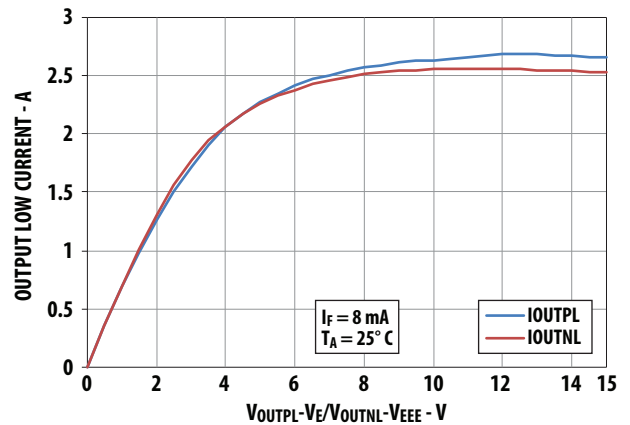

Figure 4.  $I_{OUTPL}/I_{OUTNL}$  vs.  $V_{OUTPL}/V_{OUTNL}$

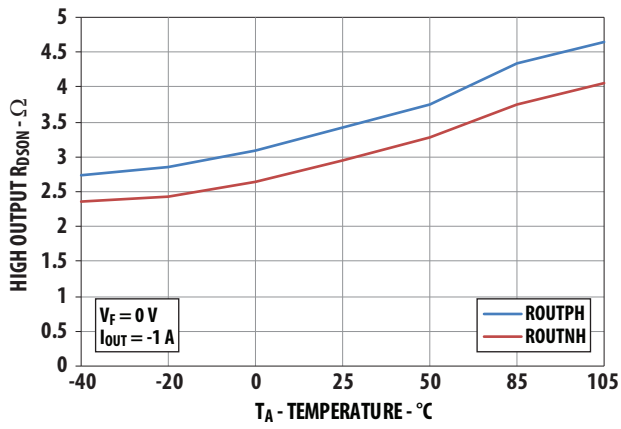

Figure 5. ROUTPH/ROUTNH vs. temperature

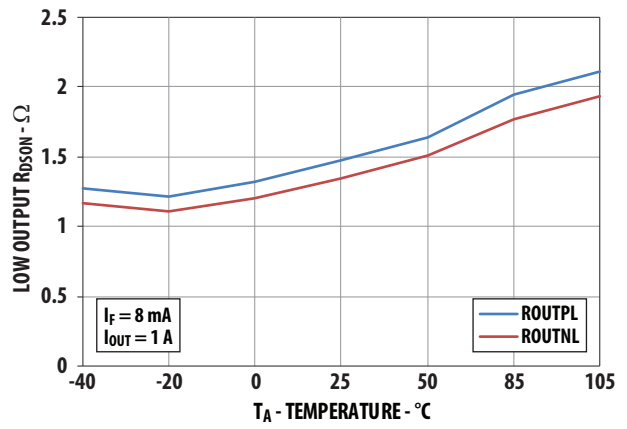

Figure 6. ROUTPL/ROUTNL vs. temperature

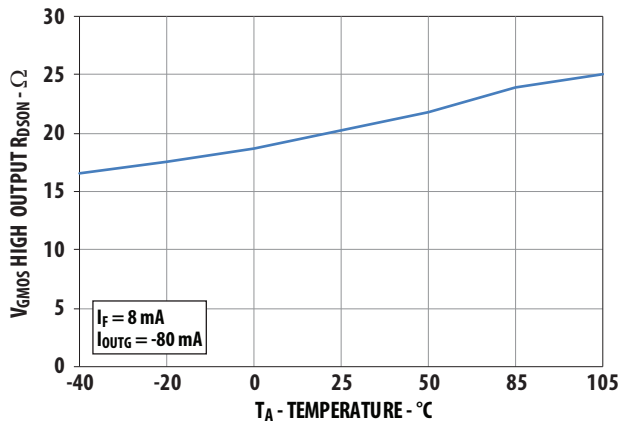

Figure 7. ROUTGH vs. temperature

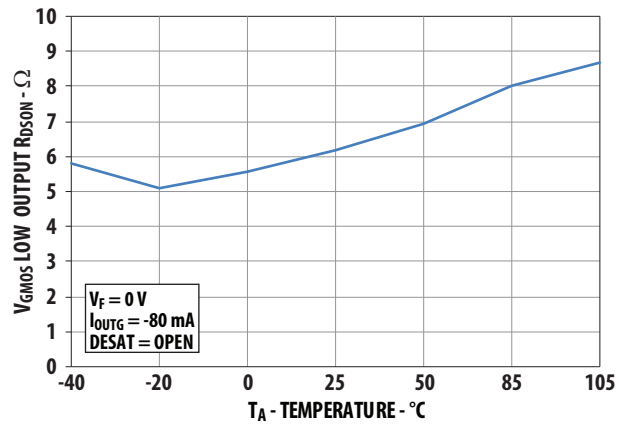

Figure 8. ROUTGL vs. temperature

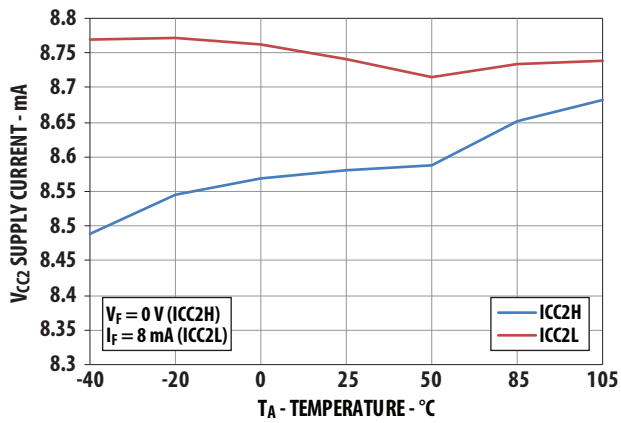

Figure 9. I<sub>C2</sub> vs. temperature

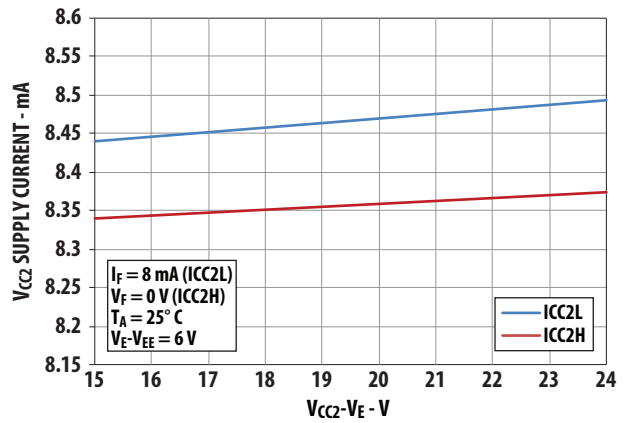

Figure 10. I<sub>C2</sub> vs. V<sub>C2</sub>

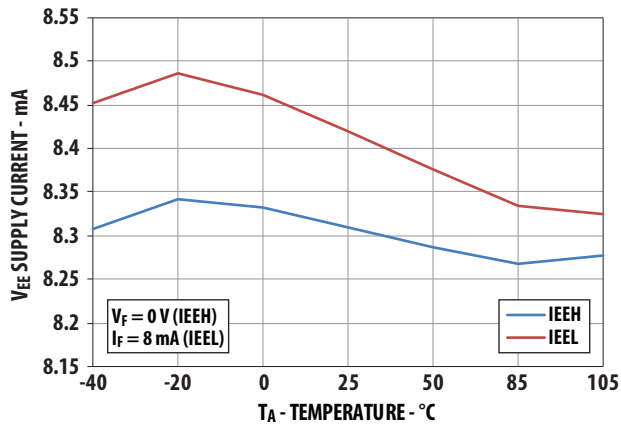

Figure 11.  $I_{EE}$  vs. temperature

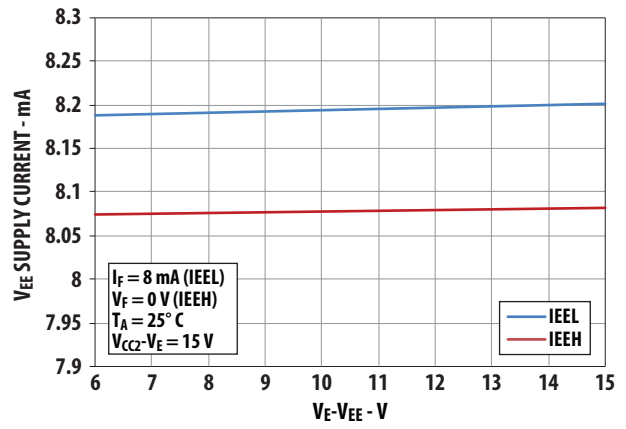

Figure 12.  $I_{EE}$  vs.  $V_{EE}$

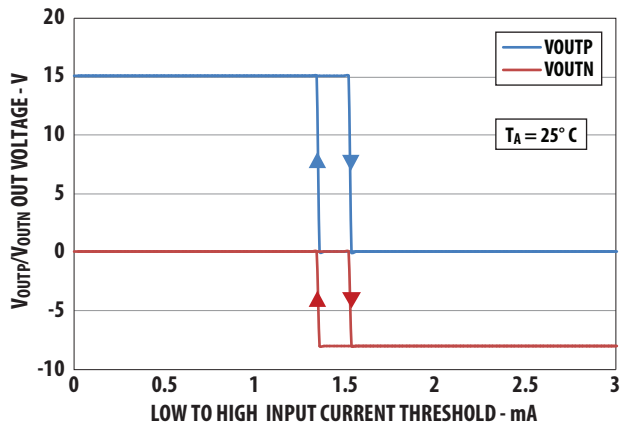

Figure 13.  $V_{OUTPH}/V_{OUTNH}$  vs.  $I_{FLH}$

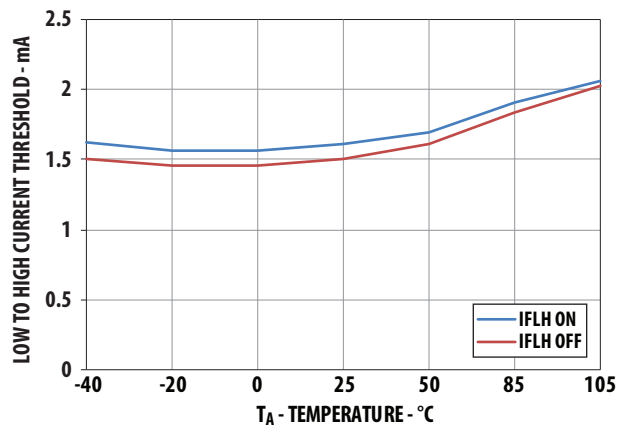

Figure 14.  $I_{FLH}$  vs. temperature

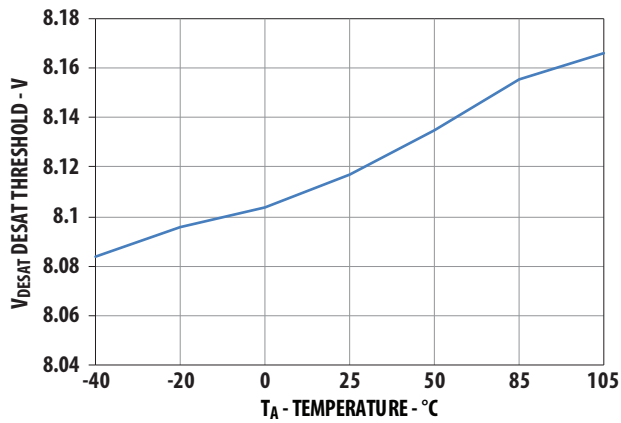

Figure 15.  $V_{DESAT}$  vs. temperature

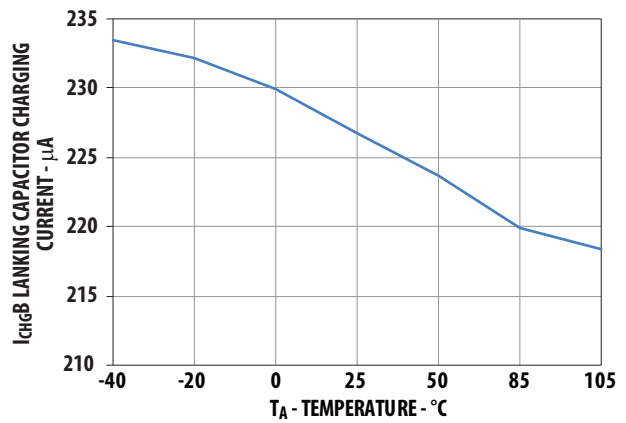

Figure 16.  $I_{CHG}$  vs. temperature

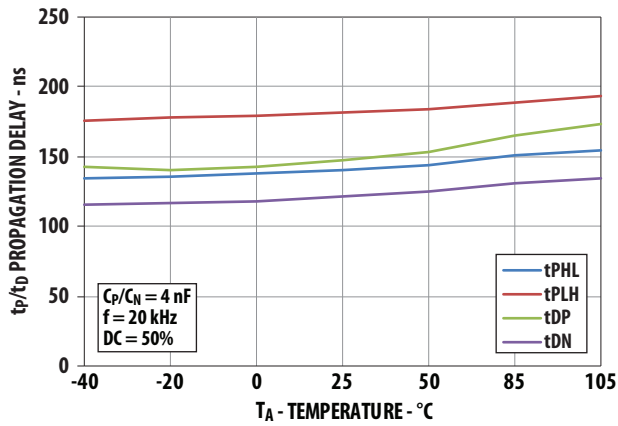

Figure 17.  $t_p/t_d$  vs. temperature

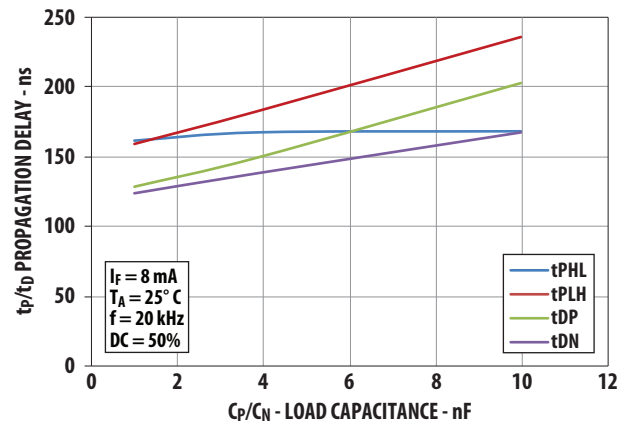

Figure 18.  $t_p/t_d$  vs.  $C_p/C_N$

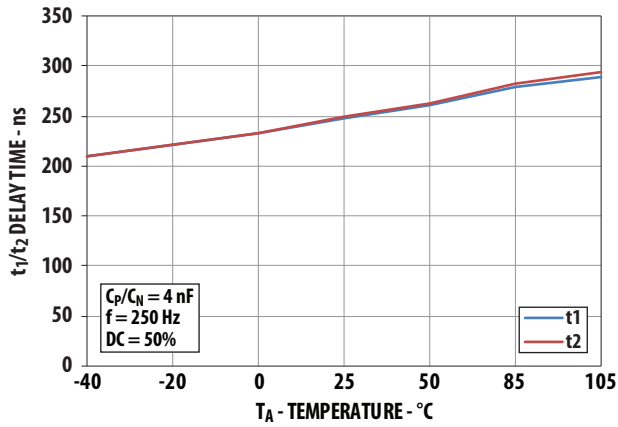

Figure 19.  $t_1/t_2$  vs. temperature

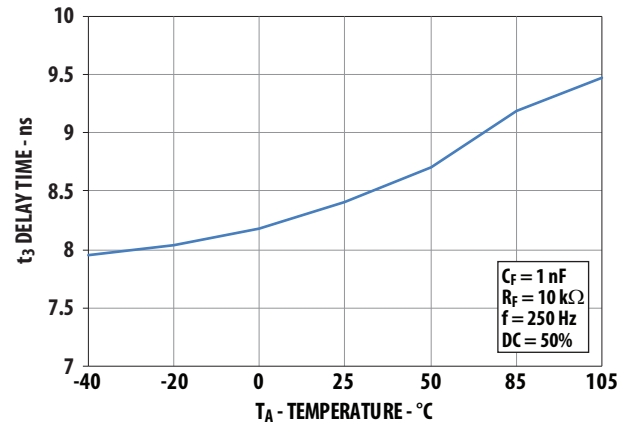

Figure 20.  $t_3$  vs. temperature

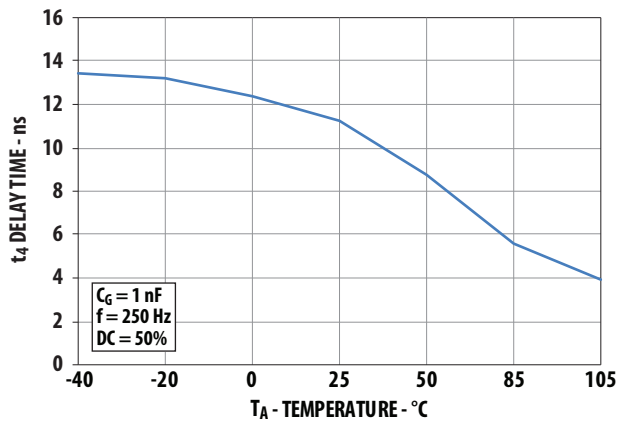

Figure 21.  $t_4$  vs. temperature

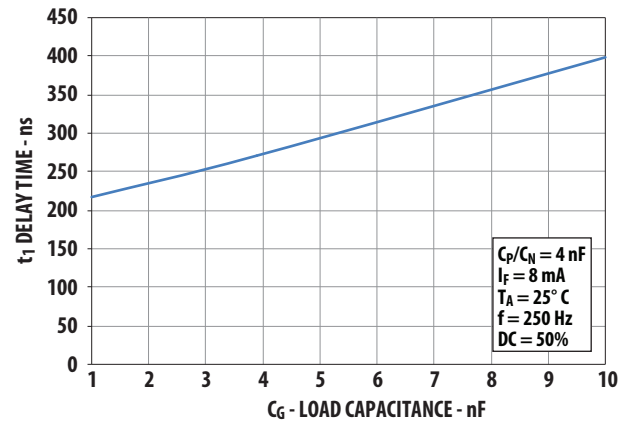

Figure 22.  $t_1$  vs.  $C_G$

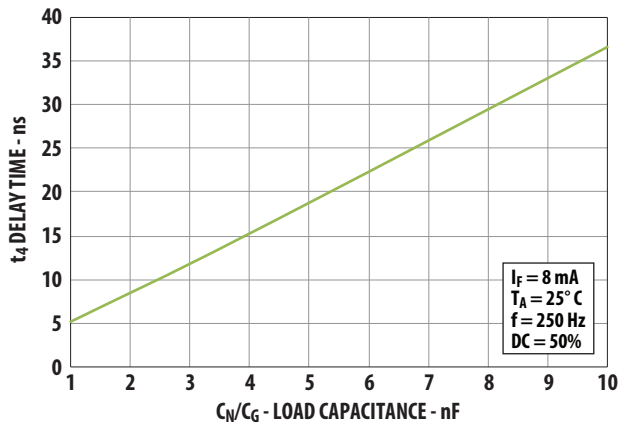

Figure 23.  $t_4$  vs.  $C_N/C_G$

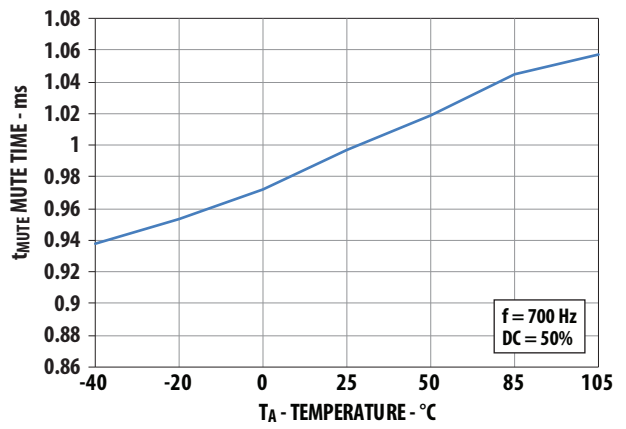

Figure 24.  $t_{MUTE}$  vs. temperature

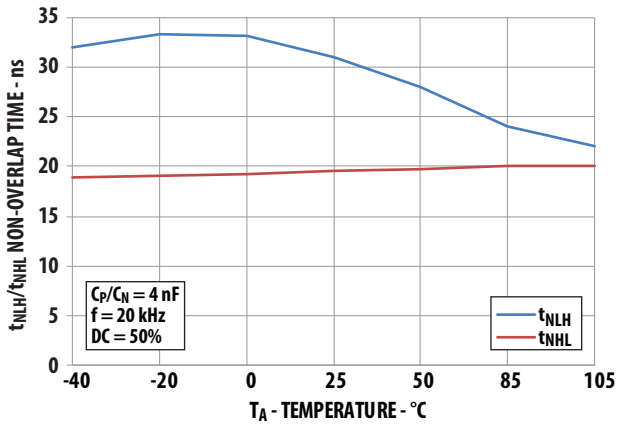

Figure 25.  $t_{NLH}/t_{NHL}$  vs. temperature

# Applications Information

## Product Overview Description

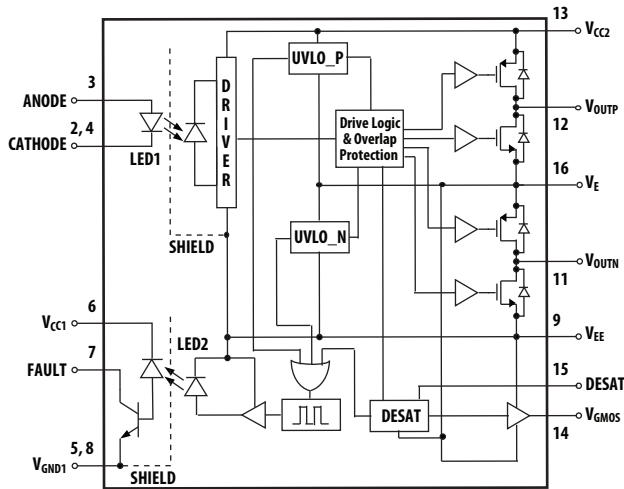

Figure 26. Block Diagram of ACPL-339J

## Recommended Application Circuit

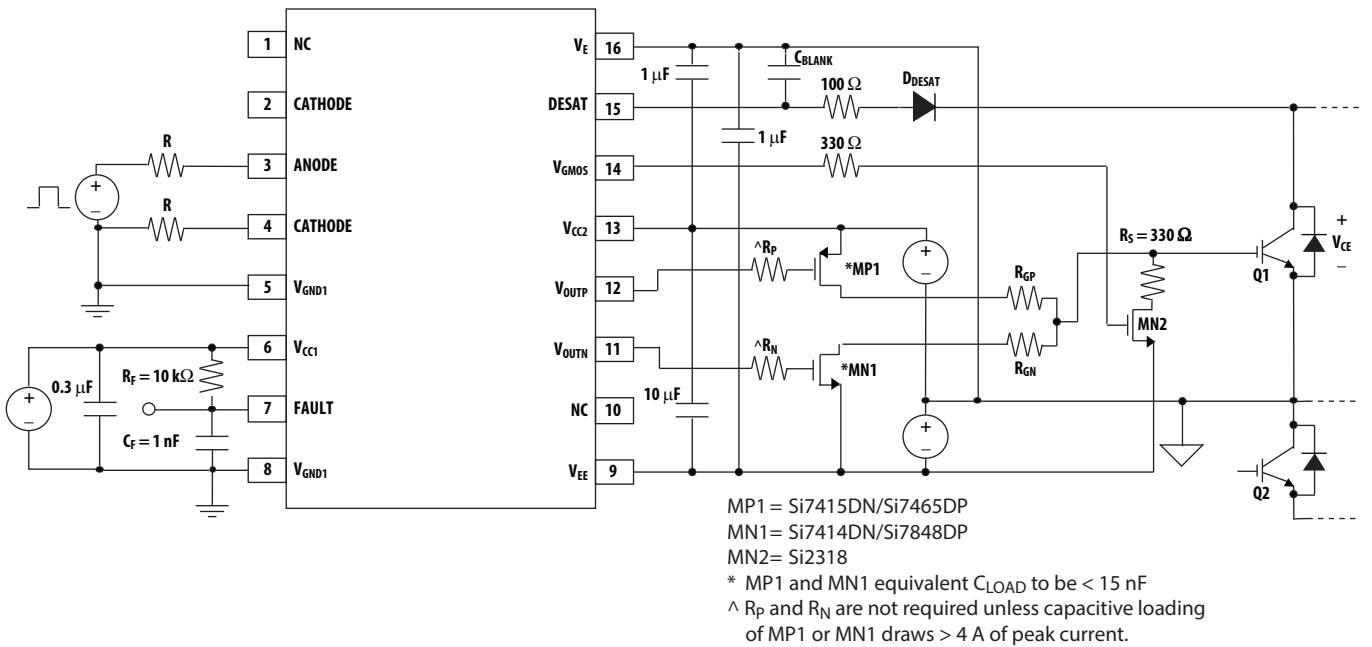

Figure 27. Typical de-saturation protected gate drive circuit, non-inverting

## Output Control

The outputs ( $V_{OUTP}$ ,  $V_{OUTN}$ ,  $V_{GMOS}$  and FAULT) of the ACPL-339J are controlled by the combination of  $I_F$ , UVLO and DESAT conditions. Once UVLO\_P and UVLO\_N is not active ( $V_{CC2} - V_E > V_{UVLOP+}$ ,  $V_E - V_{EE} > V_{UVLON+}$ ),  $V_{OUTP}$  is allowed to go low and  $V_{OUTN}$  is allowed to go high. Thereafter, the DESAT (pin 15) detection feature of the ACPL-339J will be the primary source of IGBT/MOSFET protection. DESAT will remain functional until  $V_{CC2} - V_E$  is decreased below  $V_{UVLOP-}$  or  $V_E - V_{EE}$  is decreased below  $V_{UVLON-}$ . Thus, the DESAT detection and UVLO features of the ACPL-339J work alternatively to ensure constant IGBT/MOSFET protection.

$I_F$	UVLO_P and UVLO_N	DESAT Function	Pin 7 (FAULT) Output	$V_{OUTP}$	$V_{OUTN}$	$V_{GMOS}$
X	Active	Not Active	$V_{CC1}$	$V_{CC2}$	$V_E$	$V_E$
ON	Not Active	Active (with DESAT fault)	$V_{CC1}$	$V_{CC2}$	$V_{EE}$	$V_E$
ON	Not Active	Active (no DESAT fault)	$V_{GND1}$	$V_E$	$V_{EE}$	$V_{EE}$
OFF	Not Active	Not Active	$V_{GND1}$	$V_{CC2}$	$V_E$	$V_{EE}$

## Description of Operation during DESAT Fault Condition

The DESAT pin monitors the IGBT  $V_{ce}$  voltage. The DESAT fault detection circuitry must remain disabled for a short time period following the turn-on of the IGBT to allow the collector voltage to fall below the DESAT threshold. This time period, called the DESAT blanking time, is controlled by the internal DESAT charge current, the DESAT voltage threshold, and the external DESAT capacitor. The nominal blanking time is calculated in terms of external capacitance ( $C_{BLANK}$ ), FAULT threshold voltage ( $V_{DESAT}$ ), and DESAT charge current ( $I_{CHG}$ ) as  $T_{BLANK} = C_{BLANK} \times V_{DESAT} / I_{CHG}$ . The nominal blanking time with the recommended 100 pF capacitor is  $100 \text{ pF} \times 8 \text{ V} / 250 \text{ } \mu\text{A} = 3.2 \text{ } \mu\text{sec}$ . The capacitance value can be scaled slightly to adjust the blanking time, though a value smaller than 100 pF is not recommended. This nominal blanking time also represents the longest time it will take for the ACPL-339J to respond to a DESAT fault condition. Once DESAT fault is detected and after  $T_{BLANK}$  time, both  $V_{OUTP}$  and  $V_{OUTN}$  will turn off the respective external MP1 and MN1 and  $V_{GMOS}$  switches from low to high, turning on an external MN2 pull down device, in order to 'softly' turn-off the IGBT. Also activated is an internal feedback channel which brings the FAULT output from low to high for the purpose of notifying the micro-controller of the fault condition.

Once fault is detected, the output will be muted for  $T_{MUTE}$  time. All input LED signals will be ignored during the mute period to allow the driver to completely soft shut down the IGBT. The fault is auto-reset upon the 1ms (typical) mute time ( $T_{MUTE}$ ) timeout or upon LED INPUT high to low transition, whichever is later. In this way, there is a minimum timeout but also the flexibility of lengthening the timeout freely. See Figure 28 and 29.

## Soft IGBT Shut Down during Fault Condition

When a DESAT fault is detected,  $V_{GMOS}$  switches from low to high, turning on an external MN2 pull down device. MN2 slowly discharges the IGBT gate at a decay rate corresponding to the RC constant of  $R_S$  and  $C_{IN}$  (IGBT input capacitance). Based on a  $R_S$  of 330  $\Omega$  and  $C_{IN}$  of 10 nF, the entire soft shut down will decay in  $4.8 \times 330 \Omega \times 10 \text{ nF} = 15.8 \text{ } \mu\text{s}$ . Soft shut down prevents fast changes in the collector current that can cause damaging voltage spikes due to lead and wire inductance.

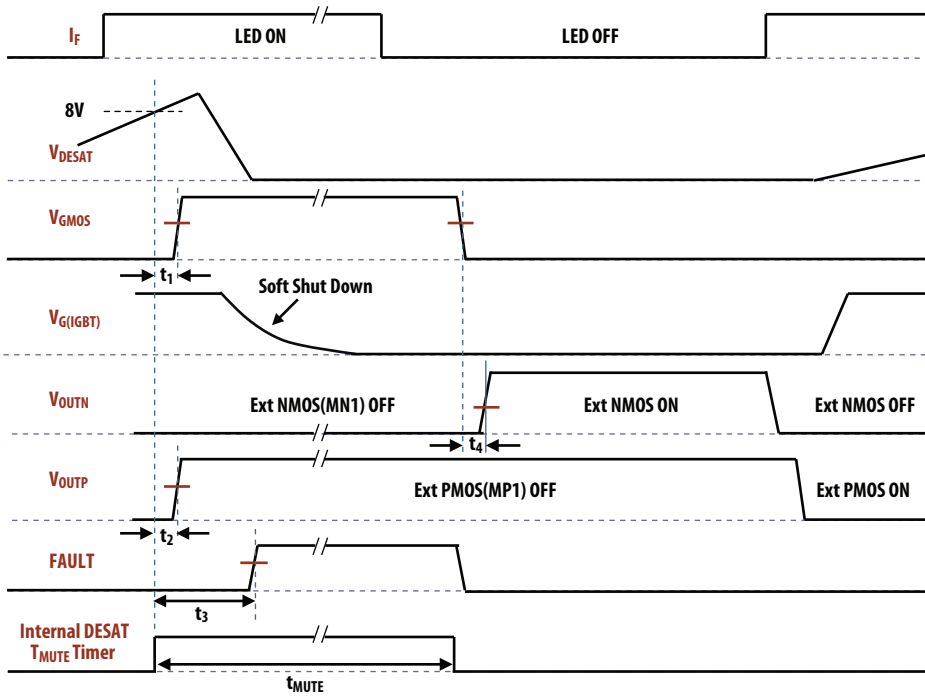

Figure 28. DESAT Fault State Timing Diagram with LED turn OFF before the  $T_{MUTE}$  timeout

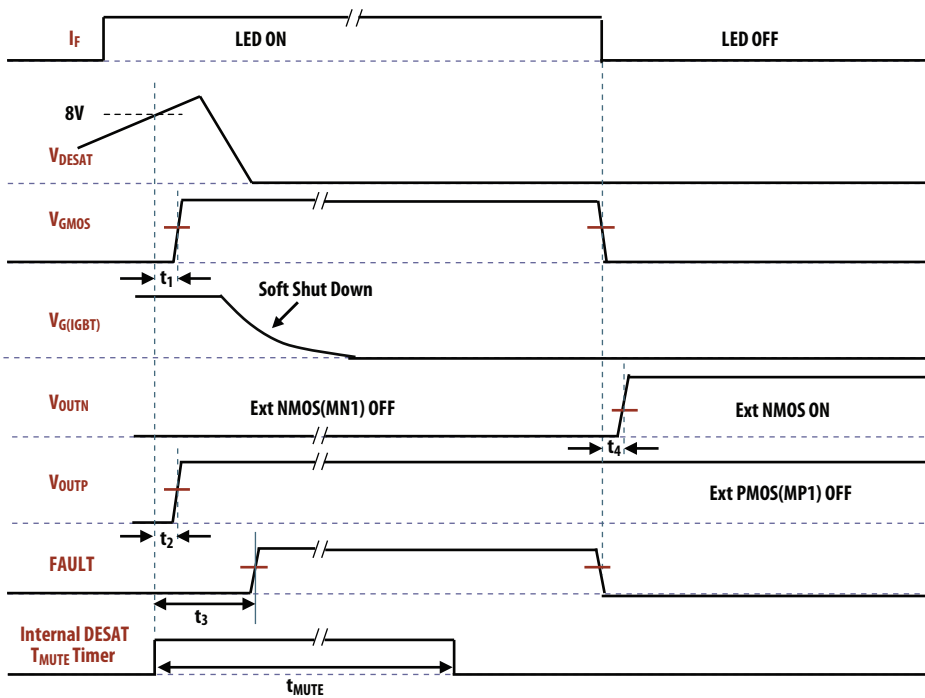

Figure 29. Desat Fault State Timing Diagram with LED OFF after the  $T_{MUTE}$  timeout



## Timing Diagram & Cross-Conduction Scheme

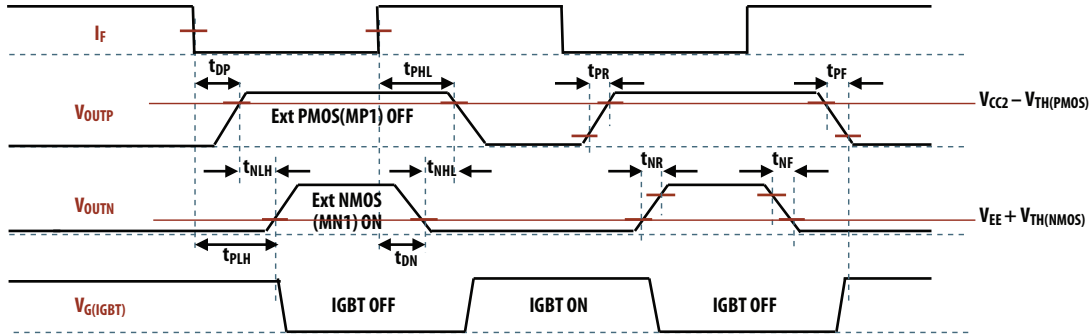

Figure 30. Timing diagram and Cross Conduction Scheme

The MOS Driver monitors  $V_{OUTP}$  &  $V_{OUTN}$  to detect for  $V_{CC2} - V_{OUTP}$  or  $V_{OUTN} - V_{EE}$  equals  $V_{TH(MOS)}$  during the respective external MOSFET's turn-off transition. Upon detection, the complimentary  $V_{OUT}$  is turned on after some inherent delay  $t_{NLH}/t_{NHL}$ .

### Description of Under Voltage Lock Out

Insufficient gate voltage to IGBT can increase turn on resistance of IGBT, resulting in large power loss and IGBT damage due to high heat dissipation. ACPL-339J monitors the output power supply constantly. When output power

supply is lower than under voltage lockout (UVLO) threshold gate driver output will shut off to protect IGBT from low voltage bias. ACPL-339J has two UVLO logic blocks, UVLO\_P and UVLO\_N to control the  $V_{OUTP}$  and  $V_{OUTN}$  respectively. The UVLO control logic takes precedence over input  $I_F$  and DESAT. In another words,  $I_F$  and DESAT are ignored when  $V_{CC2}$  and  $V_{EE}$  supplies are not sufficient causing UVLO clamp to be active. Both  $V_{UVLOP+}$  and  $V_{UVLON+}$  will need to be crossed before the clamp can be released. Thereafter,  $V_{OUTP}$  and  $V_{OUTN}$  will respond to  $I_F$  and DESAT accordingly.

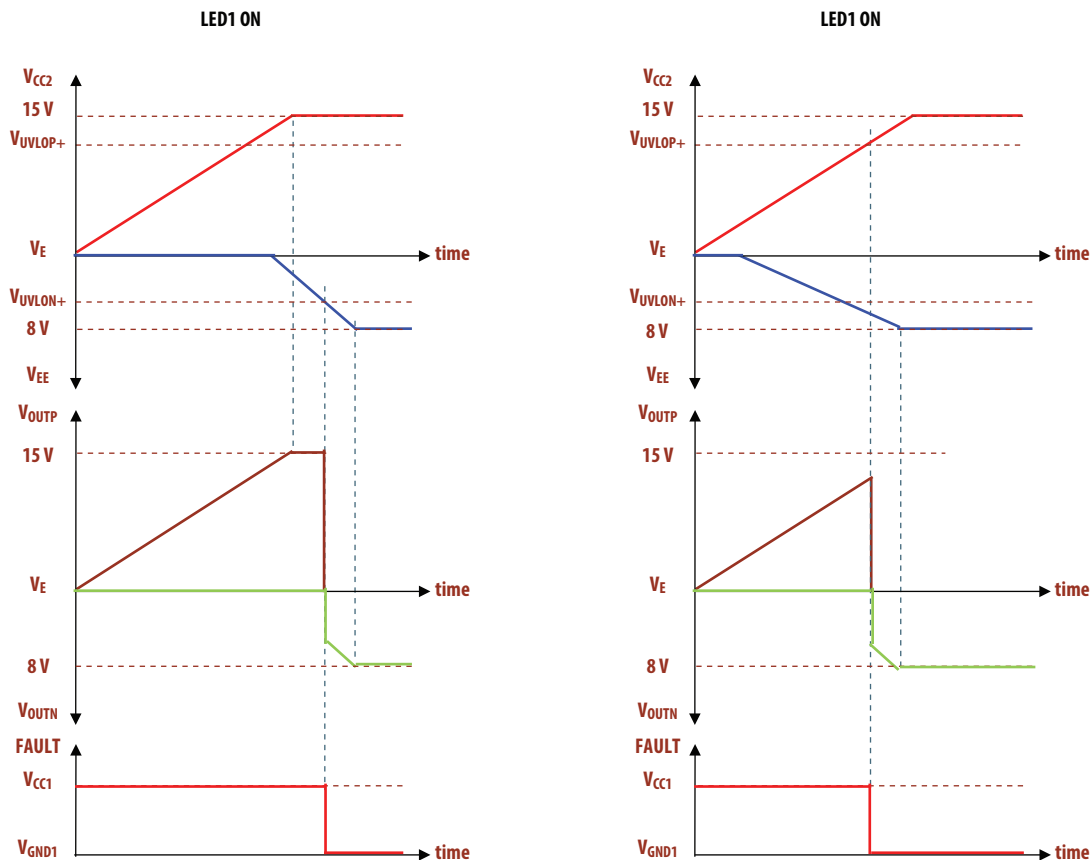

Figure 31. UVLO,  $V_{OUT}$  and FAULT logic diagram

## Drive and Shutdown MOSFET Selection

The MOSFETs, MP1 and MN1 driving strength can be estimated by the gate charge and desired charge time needed. The equation below shows an example of this:

$$Q_g = I_{\text{CHARGE}} \times T_{\text{CHARGE}}$$

$Q_g$  is the total gate charge that can be picked readily from the IGBT data sheets.

For a 1200/50 A IGBT, the typical  $Q_g$  is approximately 300 nC and for desired charging time of 200 ns, the  $I_{\text{CHARGE}}$  will be,

$$I_{\text{CHARGE}} = 300 \text{ nC} / 200 \text{ ns} = 1.5 \text{ A}$$

The charging current calculated is an average current. The peak gate current of the MOSFET driver can be estimated using the rule of thumb of doubling the  $I_{\text{CHARGE}}$ . So for this example, a 3 A peak current MOSFET driver rating will be appropriate.

The following table lists some recommended MOSFET ratings and part numbers suitable for their respective IGBT class.

Applications	IGBT Class	$Q_g$	Estimated Peak Charging Current	MN1	MP1	MN2
Low Power	1200 V / 50 A	300 nC	3A	Sanyo ECH8619	Sanyo ECH8619	Vishay SI2308
Mid Power	1200 V / 300 A	2000 nC	8A	Vishay SI7414	Vishay SI7415	Vishay SI2308
High Power	1200 V / 600 A	4000 nC	16A	Vishay SIS434	Vishay SI7611	Fairchild FDC5612

## Selecting the Gate Resistor ( $R_G$ )

The IGBT switching time is determined by the charging and discharging of the gate of the IGBT. Higher gate peak current will decrease the turn-on and turn-off time and hence reduce the the switching losses. The charging and discharging currents are controlled by the gate resistors  $R_{GP}$  and  $R_{GN}$  respectively. The  $R_G$  must be able to limit the peak current below the maximum allowed for the PMOS(MP1) and NMOS(MN1). The internal  $R_{\text{DSON}}$  of MP1 and MN1 must be taken into account when calculating the peak current.

$$R_{GP} \geq \frac{V_{CC} - V_{EE}}{I_{OP(\text{MAX})}} - R_{\text{DSONP}} \quad R_{GN} \geq \frac{V_{CC} - V_{EE}}{I_{ON(\text{MAX})}} - R_{\text{DSONN}}$$

## Other Recommended Components

The application circuit in Figure 27 includes a DESAT pin protection resistor, FAULT pin capacitor and pull-up resistor, and false FAULT prevention diodes.

## Split Resistors Input LED Drive Circuit

Figure 32 shows the recommended drive circuit that gives optimum common-mode rejection. The two current setting resistors balance the common mode impedances at the LED's anode and cathode. This helps to equalize the common mode voltage change at the anode and cathode.

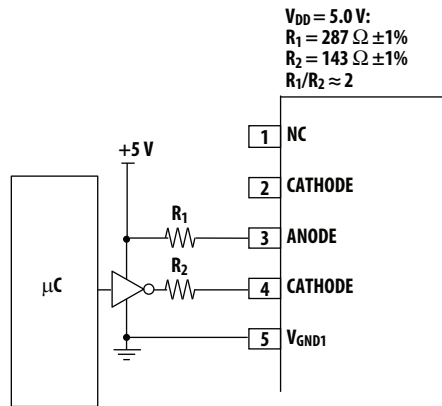

Figure 32. Split Resistors Input LED Drive Circuit

## DESAT Diode and DESAT Threshold

The DESAT diode's function is to conduct forward current, allowing sensing of the IGBT's saturated collector-to-emitter voltage,  $V_{CESAT}$ , (when the IGBT is "on") and to block high voltages (when the IGBT is "off").

During IGBT switching off and towards the end of the forward conduction of the DESAT diode, a reverse current flow for short time. This reverse recovery effect causes the diode not able to achieve its blocking capability until the mobile charge in the junction is depleted. During this time, there is commonly a very high  $dV_{CE}/dt$  voltage ramp rate across the IGBT's collector-to-emitter.

This results in  $I_{CHARGE} = C_{D-DESAT} \times dV_{CE}/dt$  charging current which will charge the blanking capacitor,  $C_{BLANK}$ . In order to minimize this charging current and avoid false DESAT triggering, it is best to use fast response diodes. Listed in the below table are fast-recovery diodes that are suitable for use as a DESAT diode ( $D_{DESAT}$ ).

In the recommended application circuit shown in Figure 27, the voltage on pin 15 (DESAT) is  $V_{DESAT} = V_F + V_{CE}$ , (where  $V_F$  is the forward ON voltage of  $D_{DESAT}$  and  $V_{CE}$  is the IGBT collector-to-emitter voltage). The value of  $V_{CE}$  which triggers DESAT to signal a FAULT condition, is nominally  $8\text{ V} - V_F$ . If desired, this DESAT threshold voltage can be decreased by using multiple DESAT diodes or low voltage zener diode in series. If  $n$  is the number of DESAT diodes, the nominal threshold value becomes  $V_{CE,FAULT(TH)} = 8\text{ V} - n \times V_F$ . If a Zener diode is used, the nominal threshold value becomes  $V_{CE,FAULT(TH)} = 8\text{ V} - V_F - V_Z$ . In the case of using two diodes instead of one, diodes with half of the total required maximum reverse-voltage rating may be chosen.

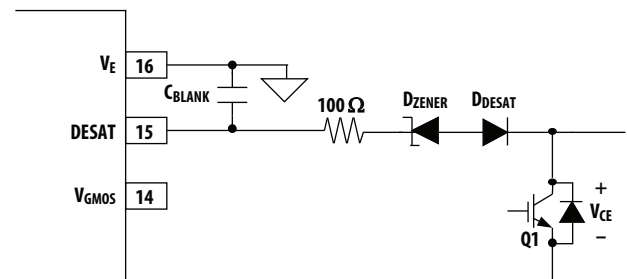

Figure 33. DESAT Diode and DESAT threshold

Part Number	Manufacturer	$t_{rr}(ns)$	Max. Reverse Voltage		Package Type
			Rating, $V_{RRM}$ (V)	$V_F$ @ 0.25 mA (V)	
MUR1100E	On-Semi	75	1000	< 0.5	59-10 (axial leaded)
MURA160T3G	On-Semi	75	600	< 0.7	Case 403A (SMD)
USIM-E3/5AT	Vishay	75	1000	< 0.6	DO-214AC (SMD)
SF1600-TR-E3	Vishay	75	1600	< 0.6	SOD-57 (axial leaded)
SF38	Multicomp	35	600	< 0.5	DO-201AD (axial leaded)

## DESAT Pin Protection Resistor

The freewheeling of flyback diodes connected across the IGBTs can have large instantaneous forward voltage transients which greatly exceed the nominal forward voltage of the diode. This may result in a large negative voltage spike on the DESAT pin which will draw substantial current out of the driver if protection is not used. To limit this current to levels that will not damage the driver IC, a 100 ohm resistor should be inserted in series with the DESAT diode. The added resistance will not alter the DESAT threshold or the DESAT blanking time.

## False Fault Prevention Diodes

One of the situations that may cause the driver to generate a false fault signal is if the substrate diode of the driver becomes forward biased. This can happen if the reverse recovery spikes coming from the IGBT freewheeling diodes bring the DESAT pin below ground. Hence the DESAT pin voltage will be 'brought' above the threshold voltage. This negative going voltage spikes is typically generated by inductive loads or reverse recovery spikes of the IGBT/MOSFETs free-wheeling diodes. In order to prevent a false fault signal, it is highly recommended to connect a zener diode and schottky diode across the DESAT pin and  $V_E$  pin

This circuit solution is shown in Figure 34. The schottky diode will prevent the substrate diode of the gate driver optocoupler from being forward biased while the zener diode (value around 7.5 to 8 V) is used to prevent any positive high transient voltage to affect the DESAT pin.

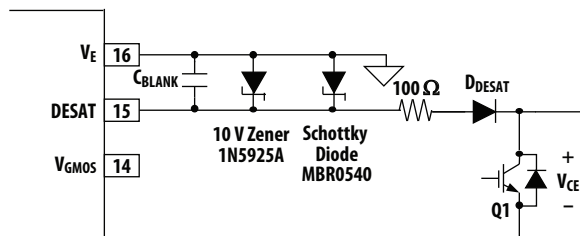

Figure 34. False fault prevention diodes

## FAULT Pin Capacitor and Pull-up Resistor

UVLO fault is feedback to the FAULT pin through LED2. If LED2 is normally-off during normal operation, a  $V_{CC2}$  or  $V_{EE}$  power supplies fault might result in insufficient drive current to turn on LED2 to report the UVLO fault. To avoid such a condition, LED2 need to be normally-on during normal operations. To reduce power consumption, LED2 operates at 50% duty cycle at a frequency of 5 MHz provided by an internal oscillator. A RC network at the FAULT pin is required to filter this oscillation to read a stable "low" for no fault condition.

The RC network consists of a FAULT pin capacitor,  $C_F$  and a pull-up resistor  $R_F$ . To achieve effective filtering and high CMR, a 1 nF capacitor should be connected between the FAULT pin and ground, and a 10 K $\Omega$  pull-up resistor between FAULT pin and  $V_{CC1}$ .

Due to the active "high" FAULT logic, the FAULT pins of more than one ACPL-339J cannot be tied together to achieve a common FAULT signal for the controller. An 'OR'ing circuit shown in Figure 35 can be used to overcome the problem.

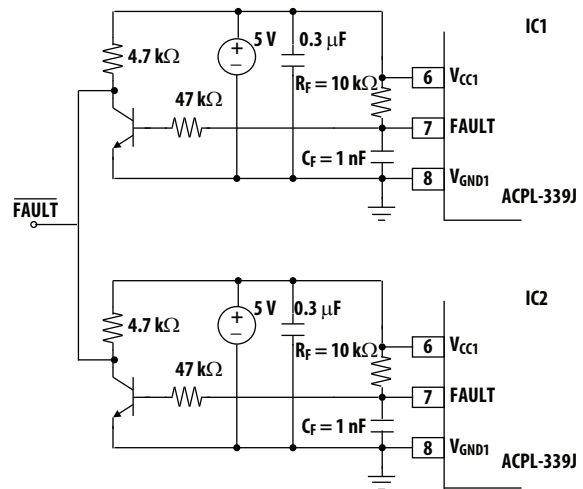

Figure 35. 'OR'ing the FAULT outputs

## Dead Time and Propagation Delay Specifications

The ACPL-339J includes a Propagation Delay Difference (PDD) specification intended to help designers minimize “dead time” in their power inverter designs. Dead time is the time period during which both the high and low side power transistors (Q1 and Q2 in Figure 37) are off. Any overlap in Q1 and Q2 conduction will result in large currents flowing through the power devices between the high and low voltage motor rails.

To minimize dead time in a given design, the turn on of LED2 should be delayed (relative to the turn off of LED1) so that under worst-case conditions, transistor Q1 has just turned off when transistor Q2 turns on, as shown in Figure 36. The amount of delay necessary to achieve this condition is equal to the maximum value of the propagation delay difference specification,  $PDD_{MAX}$ , which is specified to be 200 ns over the operating temperature range of  $-40^{\circ}\text{C}$  to  $105^{\circ}\text{C}$ .

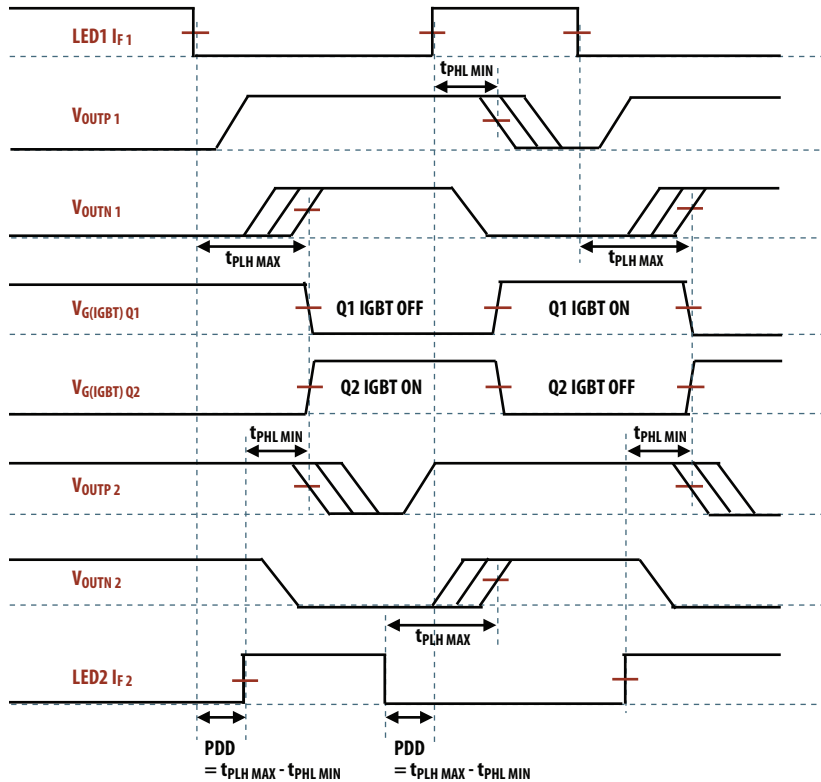

Figure 36. Minimum LED skew for zero dead time

Delaying the LED signal by the maximum propagation delay difference ensures that the minimum dead time is zero, but it does not tell a designer what the maximum dead time will be. The maximum dead time is equivalent to the difference between the maximum and minimum propagation delay difference specifications as shown in Figure 37. The maximum dead time for the ACPL-339J is 400 ns (= 200 ns - (-200 ns)) over an operating temperature range of -40° C to 105° C.

Note that the propagation delays used to calculate PDD and dead time are taken at equal temperatures and test conditions since the optocouplers under consideration are typically mounted in close proximity to each other and are switching identical IGBTs.

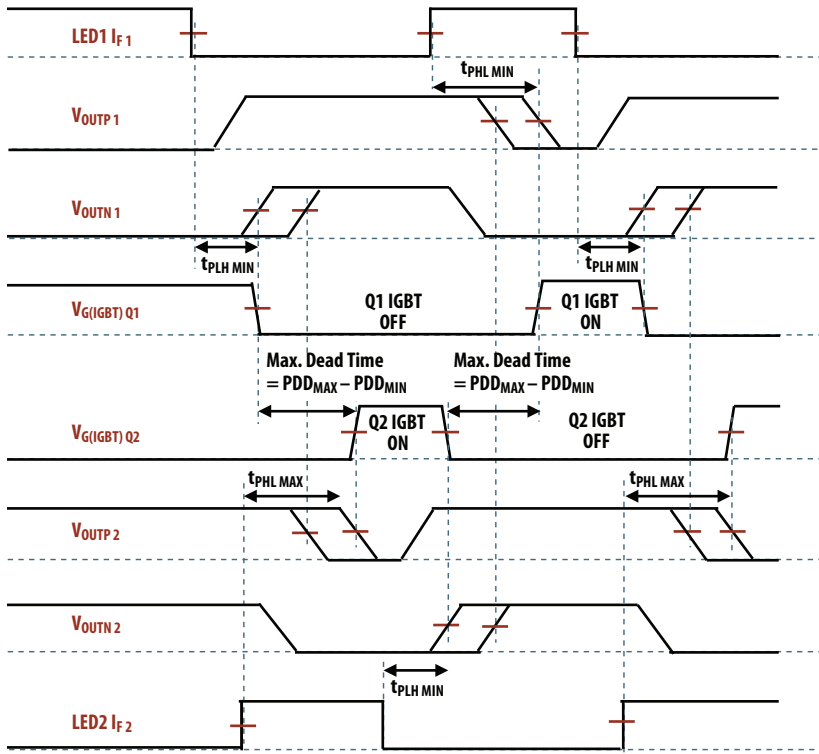

Figure 37. Waveforms for dead time