

# ACPL-344JT

Automotive 2.5A Gate-Drive Optocoupler  
with Integrated IGBT Desat Overcurrent Sensing,  
Miller-Current Clamping, and Under-Voltage Lockout Feedback

## Data Sheet

### Description

The Avago Technologies Automotive 2.5A Gate-Drive Optocoupler features fast propagation delay with excellent timing-skew performance. Smart features that are integrated to protect the IGBT include IGBT desaturation sensing with soft-shutdown protection and fault feedback, under-voltage lockout and feedback, and active Miller-current clamping. This full-featured and easy-to-implement IGBT gate-drive optocoupler comes in a compact, surface-mountable SO-16 package for space savings. It is suitable for traction power-train inverter, power converter, battery charger, air-con, and oil-pump motor drives in HEV and EV applications and satisfies automotive AEC-Q100 semiconductor requirements.

Avago's R<sup>2</sup>Coupler isolation products provide reinforced insulation and reliability that deliver safe-signal isolation critical in automotive and high-temperature industrial applications.

### Functional Diagram

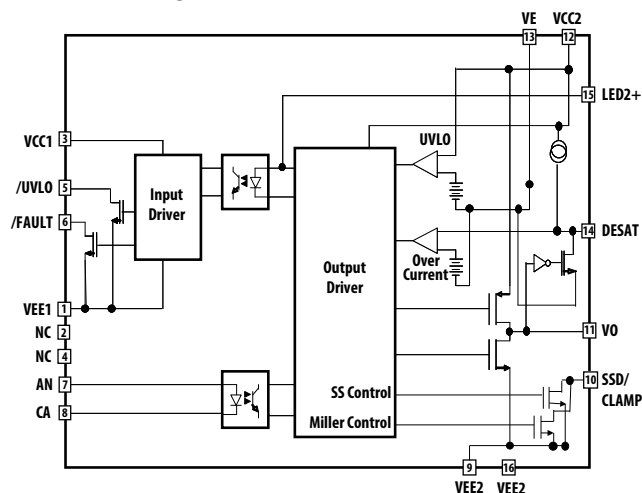

Figure 1. ACPL-344JT Functional Diagram.

### Features

- Qualified to AEC-Q100 Grade 1 Test Guidelines
- Automotive temperature range: -40°C to +125°C
- Common Mode Rejection (CMR): >50 kV/μs at V<sub>CM</sub> = 1500V
- High Noise Immunity:
  - Miller-Current Clamping
  - Direct LED input with low-input impedance and low-noise sensitivity
  - Negative Gate Bias
- Peak output current: 2.5A max.
- Miller Clamp-Sinking Current: 1.9A max.
- Wide Operating Voltage: 15V to 25V
- Propagation delay: 250 ns max.
- Integrated fail-safe IGBT protection
  - Desat sensing, 'Soft' IGBT turn-off, and Fault Feedback
  - Under-Voltage Lock-Out protection (UVLO) with Feedback
- SO-16 package with 8 mm clearance and creepage
- Regulatory approvals:
  - UL1577, CSA
  - IEC/EN/DIN EN 60747-5-5

### Applications

- Automotive isolated IGBT/MOSFET inverter gate drive
- Automotive DC-DC converter
- AC and brushless-DC motor drives
- Industrial inverters for power supplies and motor controls
- Uninterruptible power supplies (UPS)

**CAUTION:** It is advised that normal static precautions be taken in handling and assembly of this component to prevent damage and/or degradation which may be induced by ESD.

## Ordering Information

Part Number	RoHS Compliant	Package	Surface Mount	Tape and Reel	IEC/EN/DIN EN 60747-5-5	Quantity
ACPL-344JT	-000E	SO-16	X		X	45 per tube
ACPL-344JT	-500E		X	X	X	850 per reel

To order, choose a part number from the Part Number column and combine with the desired option from the RoHS Compliant column to form an order entry.

Example 1:

ACPL-344JT-500E orders the SO-16 Surface Mount package in Tape and Reel packaging with RoHS-compliant IEC/EN/DIN EN 60747-5-5 Safety Approval.

Option data sheets are available. Contact your Avago sales representative or authorized distributor for information.

## Package Outline Drawings

### 16-Lead Surface Mount

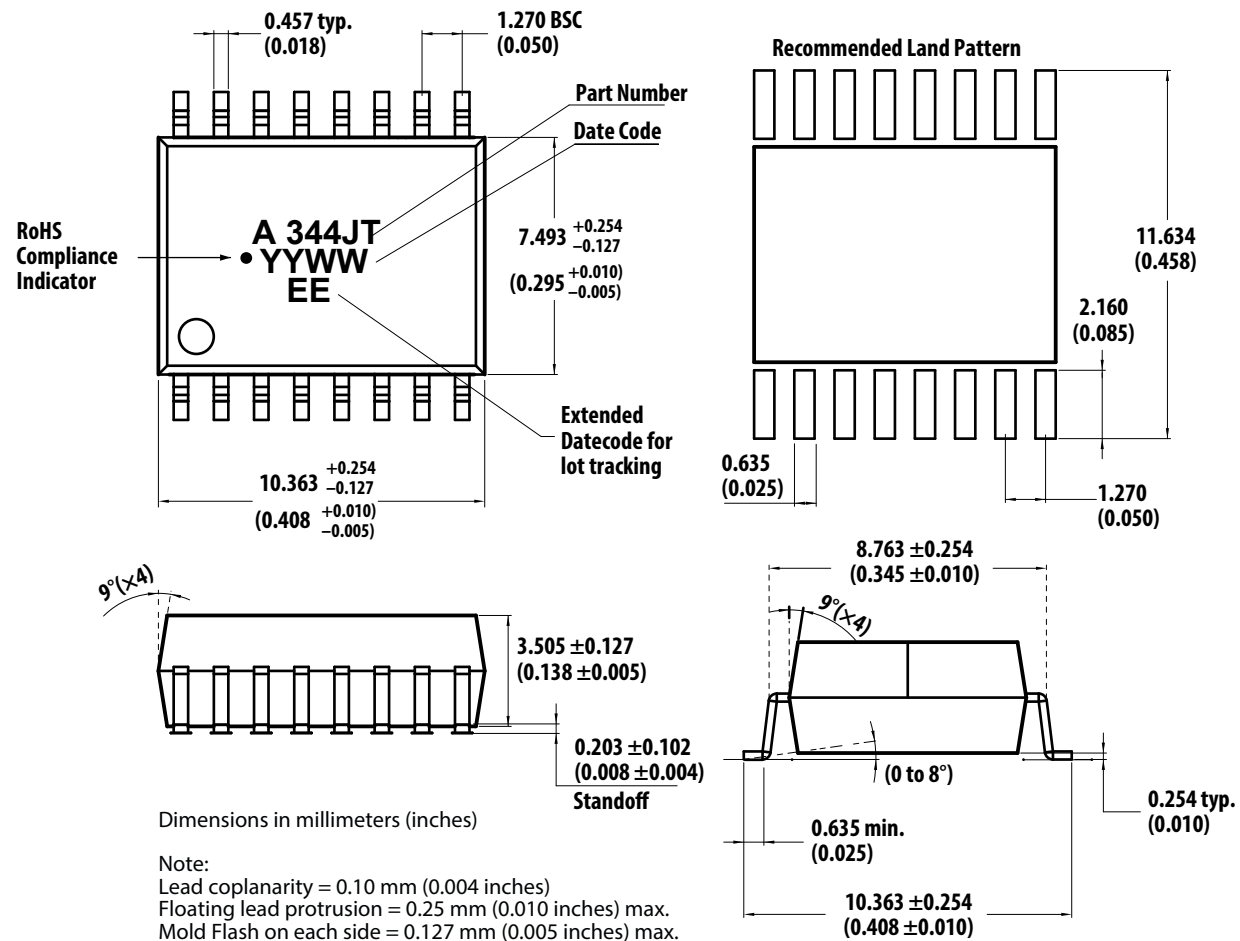

### Recommended Lead-free IR Profile

Recommended reflow condition as per JEDEC Standard, J-STD-020 (latest revision).

Non-halide flux should be used.

## Product Overview Description

The ACPL-344JT (shown in Figure 1) is a highly integrated power control device that incorporates all the necessary components for a complete, isolated IGBT gate-drive circuit. It features IGBT desaturation sensing with soft-shutdown protection and fault feedback, under-voltage lockout and feedback, and active Miller current clamping in a SO-16 package. Direct LED input allows flexible logic configuration and differential current-mode driving with low-input impedance—greatly increasing noise immunity.

### Package Pin Out

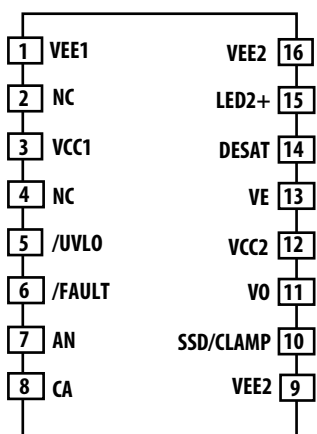

Figure 2. Pin-out of ACPL-344JT

### Pin Description

Pin Name	Function	Pin Name	Function
VEE1	Input common	VEE2	Negative power supply
NC	No connection	LED2+	No connection, for testing only
VCC1	Input power supply	DESAT	Desat overcurrent sensing
NC	No connection	VE	IGBT Emitter Reference
/UVLO	VCC2 undervoltage lockout feedback	VCC2	Positive power supply
/FAULT	Overcurrent fault feedback	VO	Driver output to IGBT gate
AN	Input LED anode	SSD/CLAMP	Soft Shutdown/Miller Current clamping output. (For proper functionality, this pin must be connected to the gate of the IGBT directly or through a current buffer.)
CA	Input LED cathode	VEE2	Negative Power Supply

## Typical Application/Operation

### Introduction to Fault Detection and Protection

The power stage of a typical three-phase inverter is susceptible to several types of failures, most of which are potentially destructive to the power IGBTs. These failure modes can be grouped into four basic categories: phase and rail supply short circuits due to user misconnect or bad wiring, control signal failures due to noise or computational errors, overload conditions induced by the load, and component failures in the gate-drive circuitry. Under any of these fault conditions, the current through the IGBTs can increase rapidly, causing excessive power dissipation and heating. The IGBTs become damaged when the current load approaches the saturation current of the device, and the collector-to-emitter voltage rises above the saturation voltage level. The drastically increased power dissipation quickly overheats the power device and destroys it. To prevent damage to the drive, fault protection must be implemented to reduce or turn-off the overcurrent during a fault condition.

A circuit providing fast local-fault detection and shutdown is an ideal solution, but the number of required components, board space consumed, cost, and complexity have, until now, limited its use to high performance drives. The features this circuit must have include high speed, low cost, low resolution, low power dissipation, and small size.

The ACPL-344JT satisfies these criteria by combining a high-speed, high-output current driver, high-voltage optical isolation between the input and output, local IGBT desaturation detection and shut down, and optically isolated fault and UVLO-status feedback signal into a single 16-pin surface-mount package.

The fault-detection method adopted in the ACPL-344JT monitors the saturation (collector) voltage of the IGBT and triggers a local-fault shutdown sequence if the collector voltage exceeds a predetermined threshold. A small gate-discharge device slowly reduces the high short-circuit IGBT current to prevent damaging voltage spikes. Before the dissipated energy can reach destructive levels, the IGBT is shut off. During the off state of the IGBT, the fault detect circuitry is simply disabled to prevent false 'fault' signals.

The alternative protection scheme of measuring IGBT current to prevent desaturation is effective if the short-circuit capability of the power device is known, but this method will fail if the gate-drive voltage decreases enough to only partially turn on the IGBT. By directly measuring the collector voltage, the ACPL-344JT limits the power dissipation in the IGBT even with insufficient gate-drive voltage. Another more subtle advantage of the desaturation detection method is that power dissipation in the IGBT is monitored, while the current sense method relies on a preset current threshold to predict the safe limit of operation. Therefore, an overly-conservative overcurrent threshold is not required to protect the IGBT.

### Recommended Application Circuit

The ACPL-344JT has non-inverting gate-control inputs, and an open-collector fault and UVLO outputs suitable for wired-OR applications.

The recommended application circuit shown in Figure 3 shows a typical gate-drive implementation using the ACPL-344JT.

The two supply bypass capacitors (1.0  $\mu\text{F}$  minimum) provide the large transient currents necessary during a switching transition. The Desat diode and 220 pF blanking capacitor are the necessary external components for the fault detection circuitry. The gate resistor (10 $\Omega$ ) serves to limit gate-charge current and indirectly control the IGBT collector voltage rise-and-fall times. The open-collector fault and UVLO outputs have a passive 10 k $\Omega$  pull-up resistor and a 330 pF filtering capacitor.

## DESAT Fault Detection Blanking Time

The DESAT fault detection circuitry must remain disabled for a short time period following the turn-on of the IGBT to allow the collector voltage to fall below the DESAT threshold. This time period, called the total DESAT blanking time, is controlled by the both internal DESAT blanking time  $t_{DESAT(BLANKING)}$  (Figure 6) and external blanking time, determined by internal charge current, the DESAT voltage threshold, and the external DESAT capacitor.

The total blanking time is calculated in terms of internal blanking time ( $t_{DESAT(BLANKING)}$ ), external capacitance ( $C_{BLANK}$ ), FAULT threshold voltage ( $V_{DESAT}$ ), and DESAT charge current ( $I_{CHG}$ ):

$$t_{BLANK} = t_{DESAT(BLANKING)} + C_{BLANK} \times V_{DESAT} / I_{CHG}$$

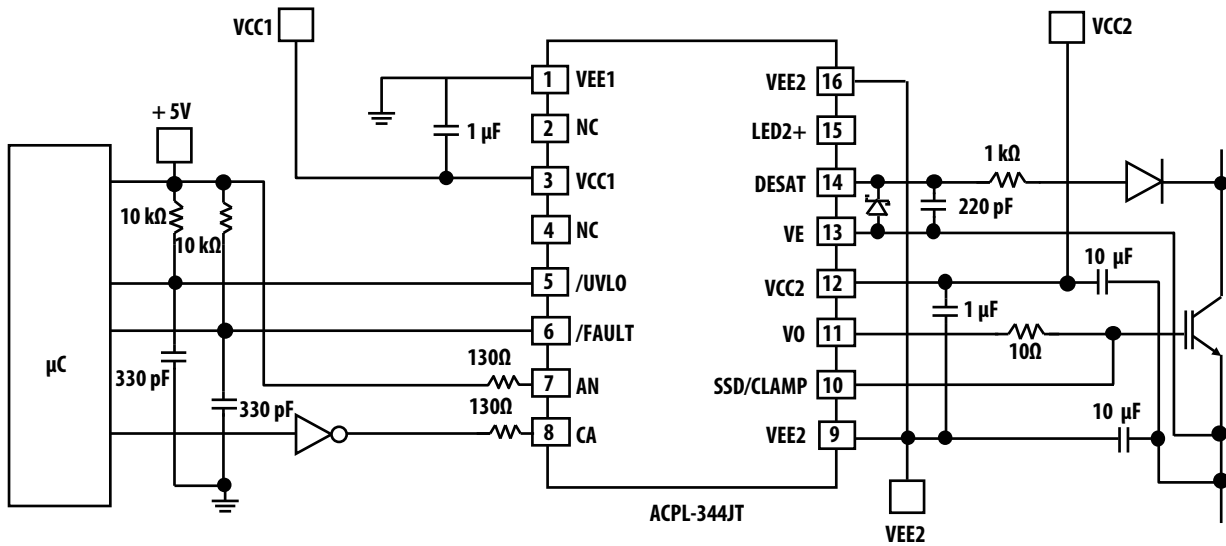

Figure 3. Typical gate-drive circuit with Desat current sensing using ACPL-344JT.

## Description of Gate Driver and Miller Clamping

The gate driver is directly controlled by the LED current. When LED current is driven HIGH, the output of ACPL-344JT is capable of delivering 2.5A sourcing current to drive the IGBT's gate. While LED is switched off, the gate driver can provide 2.5A sinking current to switch the gate off fast. An additional Miller clamping pull-down transistor is activated when output voltage reaches about 2V with respect to  $V_{EE2}$  to provide a low impedance path to Miller Current, as shown in Figure 4.

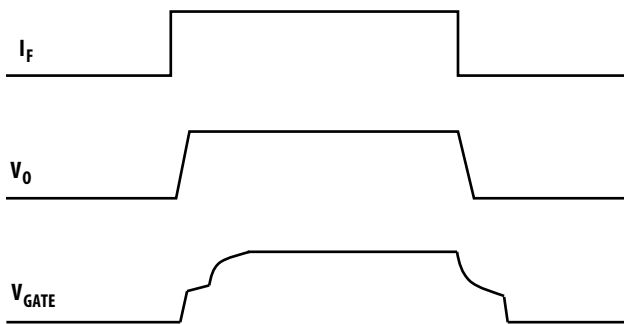

Figure 4. Gate-Drive Signal Behavior.

## Description of Under-Voltage Lockout

Insufficient gate voltage to IGBT can increase turn-on resistance of IGBT, resulting in large power loss and IGBT damage due to high heat dissipation. ACPL-344JT monitors the output power supply constantly. When output power supply is lower than under-voltage lockout (UVLO) threshold, gate-driver output shuts off to protect IGBT from low voltage bias. During power-up, the UVLO feature forces the gate driver output LOW to prevent unwanted turn-on at lower voltage.

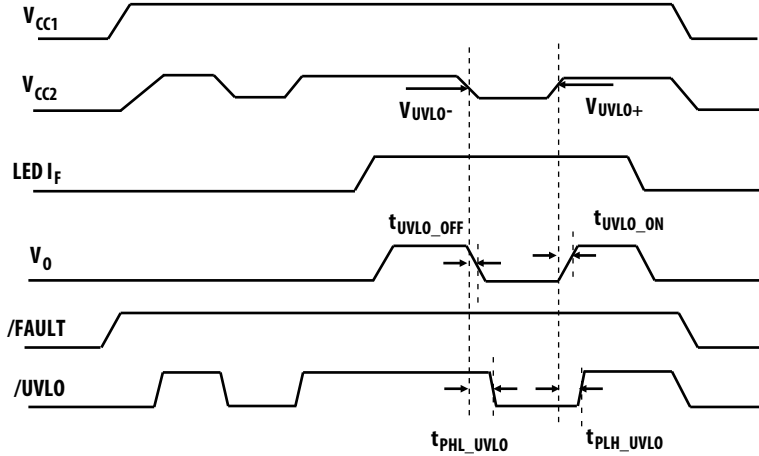

Figure 5. Circuit Behaviors at Power up and Power down.

## Description of Operation During Overcurrent Condition

1. DESAT terminal monitors IGBT's  $V_{CE}$  voltage.
2. When the voltage on the DESAT terminal exceeds 7V, the output voltage ( $V_{OUT}$ ) to IGBT gate goes to Hi-Z state and the SSD/CLAMP output is slowly lowered.
3. FAULT output goes LOW, notifying the microcontroller of the fault condition.
4. Microcontroller takes appropriate action.
5. When  $t_{DESAT(MUTE)}$  expires, LED input must be kept LOW for  $t_{DESAT(RESET)}$  before the fault condition is cleared. FAULT status returns to HIGH and SSD/CLAMP output returns to Hi-Z state.
6. Output ( $V_{OUT}$ ) starts to respond to LED input after the fault condition is cleared.

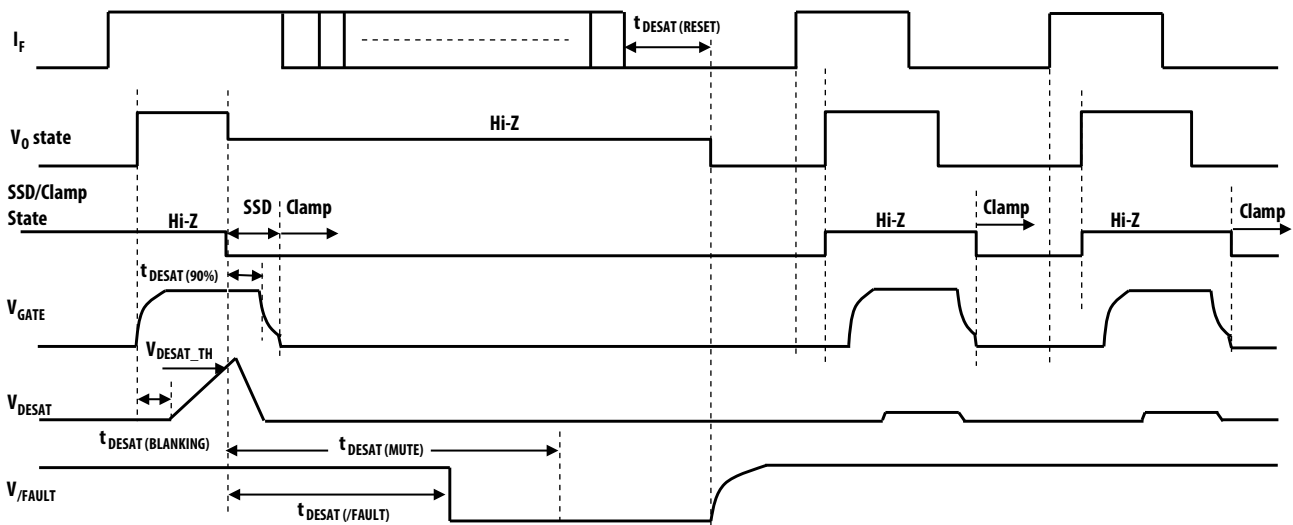

Figure 6. Circuit Behaviors During Overcurrent Event.

The ACPL-344JT is approved by the following organizations:

UL	CSA	IEC/EN/DIN EN 60747-5-5
Approved under UL 1577, component recognition program up to $V_{ISO} = 5000V_{RMS}$	Approved under CSA Component Acceptance Notice #5, File CA 88324.	Approved under IEC 60747-5-5 EN 60747-5-5 DIN EN 60747-5-5

### IEC/EN/DIN EN 60747-5-5 Insulation Characteristics

Description	Symbol	Characteristic	Unit
Insulation Classification per DIN VDE 0110/1.89, Table 1 for rated mains voltage $\leq 150V_{RMS}$ for rated mains voltage $\leq 300V_{RMS}$ for rated mains voltage $\leq 600V_{RMS}$ for rated mains voltage $\leq 1000V_{RMS}$		I – IV I – IV I – IV I – III	
Climatic Classification		40/125/21	
Pollution Degree (DIN VDE 0110/1.89)		2	
Maximum Working Insulation Voltage	$V_{IORM}$	1230	$V_{PEAK}$
Input to Output Test Voltage, Method b $V_{IORM} \times 1.875 = V_{PR}$ , 100% Production Test with $t_m = 1$ sec, Partial discharge $< 5$ pC	$V_{PR}$	2306	$V_{PEAK}$
Input to Output Test Voltage, Method a $V_{IORM} \times 1.6 = V_{PR}$ , Type and Sample Test, $t_m = 10$ sec, Partial Discharge $< 5$ pC	$V_{PR}$	1968	$V_{PEAK}$
Highest Allowable Overvoltage (Transient Overvoltage $t_{ini} = 60$ sec)	$V_{IOTM}$	8000	$V_{PEAK}$
Safety-limiting values – maximum values allowed in the event of a failure (also see Figure 7)			
Case Temperature	$T_S$	175	$^{\circ}C$
Input Power	$P_{S,INPUT}$	400	mW
Output Power	$P_{S,OUTPUT}$	1200	mW
Insulation Resistance at $T_S, V_{IO} = 500$ V	$R_S$	$>10^9$	$\Omega$

Notes:

1. Isolation characteristics are guaranteed only within the safety maximum ratings which must be ensured by protective circuits in application. Surface mount classification is class A in accordance with CECC00802.
2. Refer to the optocoupler section of the Isolation and Control Components Designer's Catalog, under Product Safety Regulation section IEC/EN/DIN EN 60747-5-5, for a detailed description of Method a and Method b partial-discharge test profiles.

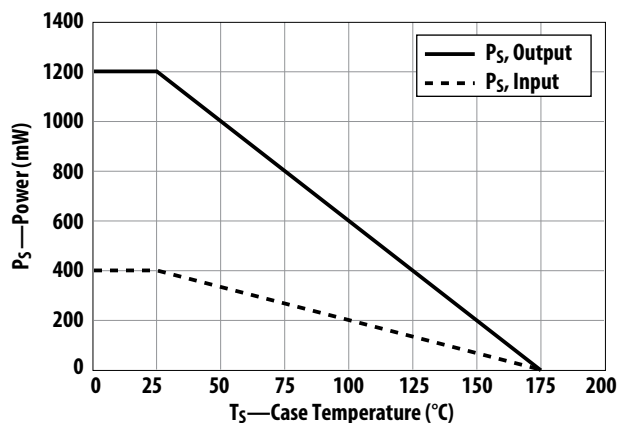

Figure 7. Dependence of safety limiting values on temperature.

## Insulation and Safety Related Specifications

Parameter	Symbol	Value	Units	Conditions
Minimum External Air Gap (Clearance)	L(101)	8.3	mm	Measured from input terminals to output terminals, shortest distance through air.
Minimum External Tracking (Creepage)	L(102)	8.3	mm	Measured from input terminals to output terminals, shortest distance path along body.
Minimum Internal Plastic Gap (Internal Clearance)		0.5	mm	Through insulation distance conductor to conductor, usually the straight line distance thickness between the emitter and detector.
Tracking Resistance (Comparative Tracking Index)	CTI	>175	V	DIN IEC 112/VDE 0303 Part 1
Isolation Group			IIIa	Material Group (DIN VDE 0110)

## Absolute Maximum Ratings

Unless otherwise specified, all voltages at input IC reference to  $V_{EE1}$ , all voltages at output IC reference to  $V_{EE2}$ .

Parameter	Symbol	Min.	Max.	Units	Note
Storage Temperature	$T_S$	-55	+150	°C	
Operating Temperature	$T_A$	-40	+125	°C	
IC Junction Temperature	$T_J$		150	°C	1
Average Input Current	$I_{F(AVG)}$		20	mA	
Peak Transient Input Current (<1 $\mu$ s pulse width, 300 pps)	$I_{F(TRAN)}$		1	A	
Reverse Input Voltage	$V_R$		6	V	
/Fault Output Current (Sinking)	$I_{/FAULT}$		10	mA	
/Fault Pin Voltage	$V_{/FAULT}$	-0.5	+6	V	
/UVLO Output Current (Sinking)	$I_{/UVLO}$		10	mA	
/UVLO Pin Voltage	$V_{/UVLO}$	-0.5	+6	V	
Positive Input Supply Voltage	$V_{CC1}$	-0.5	+26	V	
Total Output Supply Voltage	$V_{CC2}-V_{EE2}$	-0.5	+30	V	
Negative Output Supply Voltage	$V_{EE2}-V_E$	-15	+0.5	V	2
Positive Output Supply Voltage	$V_{CC2}-V_E$	-0.5	+30	V	
Gate-Drive Output Voltage	$V_o(\text{peak})$	-0.5	$V_{CC2} + 0.5$	V	
Peak Output Current	$ I_{O(\text{peak})} $		2.5	A	3
Peak Clamping Sinking Current	$I_{CLAMP}$		2	A	3
Miller Clamping Pin Voltage	$V_{CLAMP}-V_{EE2}$	-0.5	$V_{CC2} + 0.5$	V	
Desat Voltage	$V_{DESAT}-V_E$	$V_E - 0.5$	$V_{CC2} + 0.5$	V	4
Output IC Power Dissipation	$P_O$		580	mW	1
Input IC Power Dissipation	$P_I$		150	mW	



## Recommended Operating Conditions

Parameter	Symbol	Min.	Max.	Units	Notes
Operating Temperature	$T_A$	-40	+125	°C	
Input Supply Voltage	$V_{CC1}$	8	18	V	
Total Output Supply Voltage	$V_{CC2}-V_{EE2}$	15	25	V	5
Negative Output Supply Voltage	$V_{EE2}-V_E$	-10	0	V	3
Positive Output Supply Voltage	$V_{CC2}-V_E$	15	25	V	
Input LED Current	$I_{F(ON)}$	10	16	mA	
Input Voltage (OFF)	$V_{F(OFF)}$	-5.5	+0.8	V	
Input Pulse Width	$t_{ON(LED)}$	500		ns	

## Electrical Specifications

Unless otherwise specified, all Minimum/Maximum specifications are at recommended operating conditions, all voltages at input IC are referenced to  $V_{EE1}$ , all voltages at output IC referenced to  $V_{EE2}$ . All typical values at  $T_A = 25^\circ\text{C}$ ,  $V_{CC1} = 12\text{V}$ ,  $V_{CC2}-V_{EE2} = 20\text{V}$ ,  $V_E-V_{EE2} = 0\text{V}$ .

Parameter	Symbol	Min.	Typ.	Max.	Units	Test Conditions	Fig.	Note
<b>IC Supply Current</b>								
Input Supply Current	$I_{CC1}$		3.7	6.0	mA		8	
Output Low Supply Current	$I_{CC2L}$		10.5	13.2	mA	$I_F = 0\text{ mA}$ $V_{CC2} = 20\text{V}$	9	
Output High Supply Current	$I_{CC2H}$		10.6	13.6	mA	$I_F = 10\text{ mA}$ $V_{CC2} = 20\text{V}$	9	
<b>Logic Input and Output</b>								
LED Forward Voltage ( $V_{AN} - V_{CA}$ )	$V_F$	1.25	1.55	1.85	V	$I_F = 10\text{ mA}$	10	
LED Reverse Breakdown Voltage ( $V_{CA} - V_{AN}$ )	$V_{BR}$	6			V	$I_F = -10\text{ }\mu\text{A}$		
LED Input Capacitance	$C_{IN}$		90		pF			
LED Turn-on Current Threshold Low to High	$I_{TH+}$		2.7	6.6	mA	$V_O = 5\text{V}$	11	
LED Turn-on Current Threshold High to Low	$I_{TH-}$		2.1	6.4	mA	$V_O = 5\text{V}$	11	
LED Turn-on Current Hysteresis	$I_{TH\_HYS}$		0.6		mA			
FAULT Logic Low Output Current	$I_{FAULT\_L}$	4.0	9.0		mA	$V_{/FAULT} = 0.4\text{V}$		
FAULT Logic High Output Current	$I_{FAULT\_H}$			20	$\mu\text{A}$	$V_{/FAULT} = 5\text{V}$		
UVLO Logic Low Output Current	$I_{UVLO\_L}$	4.0	9.0		mA	$V_{/UVLO} = 0.4\text{V}$		
UVLO Logic High Output Current	$I_{UVLO\_H}$			20	$\mu\text{A}$	$V_{/UVLO} = 5\text{V}$		

## Electrical Specifications (continued)

Unless otherwise specified, all Minimum/Maximum specifications are at recommended operating conditions, all voltages at input IC are referenced to  $V_{EE1}$ , all voltages at output IC referenced to  $V_{EE2}$ . All typical values at  $T_A = 25^\circ\text{C}$ ,  $V_{CC1} = 12\text{ V}$ ,  $V_{CC2} - V_{EE2} = 20\text{ V}$ ,  $V_E - V_{EE2} = 0\text{ V}$ .

Parameter	Symbol	Min.	Typ.	Max.	Units	Test Conditions	Fig.	Note
<b>Gate Driver</b>								
High Level Output Current	$I_{OH}$		-2.0	-0.75	A	$V_O = V_{CC2} - 3\text{ V}$	12	4
Low Level Output Current	$I_{OL}$	1.0	2.2		A	$V_O = V_{EE2} + 2.5\text{ V}$	13	4
High Level Output Voltage	$V_{OH}$	$V_{CC2} - 0.5$	$V_{CC2} - 0.2$		V	$I_O = -100\text{ mA}$		6-8
Low Level Output Voltage	$V_{OL}$		0.1	0.5	V	$I_O = 100\text{ mA}$		
$V_{IN}$ to High Level Output Propagation Delay Time	$t_{PLH}$	50	130	250	ns	$V_{source} = 5\text{ V}$ $R_f = 260\Omega$ $R_g = 10\Omega$ $C_{load} = 10\text{ nF}$ $f = 10\text{ kHz}$ Duty Cycle = 50%	14,19	9
$V_{IN}$ to Low Level Output Propagation Delay Time	$t_{PHL}$	50	150	250	ns		14,19	10
Pulse Width Distortion	PWD	-100	+20	+100	ns			11,12
Dead Time Distortion ( $t_{PLH} - t_{PHL}$ )	DTD	-150	-40	+105	ns			12,13
10% to 90% Rise Time	$t_R$		70		ns			
90% to 10% Fall Time	$t_F$		50		ns			
Output High Level Common Mode Transient Immunity	$ CM_H $	50	>70		kV/ $\mu\text{s}$	$T_A = 25^\circ\text{C}$ , $I_F = 10\text{ mA}$ $V_{CM} = 1500\text{ V}$	21	14
Output Low Level Common Mode Transient Immunity	$ CM_L $	50	>70		kV/ $\mu\text{s}$	$T_A = 25^\circ\text{C}$ , $I_F = 0\text{ mA}$ $V_{CM} = 1500\text{ V}$	21	15
<b>Active Miller Clamp and Soft Shutdown</b>								
Low Level Soft Shutdown Current During Fault Condition	$I_{SSD}$	22	35	48	mA	$V_{SSD} - V_{EE2} = 14\text{ V}$	15	
Clamp Threshold Voltage	$V_{TH\_CLAMP}$		2.0	3.0	V			
Clamp Low Level Sinking Current	$I_{CLAMP}$	0.75	1.9		A	$V_{CLAMP} = V_{EE2} + 2.5\text{ V}$		
<b><math>V_{CC2}</math> UVLO Protection (UVLO voltage <math>V_{UVLO}</math> reference to <math>V_E</math>)</b>								
$V_{CC2}$ UVLO Threshold Low to High	$V_{UVLO+}$	11.0	12.4	13.7	V	$V_O > 5\text{ V}$		8,16
$V_{CC2}$ UVLO Threshold High to Low	$V_{UVLO-}$	10.1	11.3	12.8	V	$V_O < 5\text{ V}$		8,17
$V_{CC2}$ UVLO Hysteresis	$V_{UVLO\_HYS}$		1.1		V			8
$V_{CC2}$ to UVLO High Delay	$t_{PLH\_UVLO}$		10		$\mu\text{s}$			18
$V_{CC2}$ to UVLO Low Delay	$t_{PHL\_UVLO}$		10		$\mu\text{s}$			19
$V_{CC2}$ UVLO to $V_{OUT}$ High Delay	$t_{UVLO\_ON}$		10		$\mu\text{s}$			20
$V_{CC2}$ UVLO to $V_{OUT}$ Low Delay	$t_{UVLO\_OFF}$		10		$\mu\text{s}$			21

## Electrical Specifications (continued)

Unless otherwise specified, all minimum/maximum specifications are at recommended operating conditions, all voltages at input IC are referenced to  $V_{EE1}$ , all voltages at output IC referenced to  $V_{EE2}$ . All typical values at  $T_A = 25^\circ\text{C}$ ,  $V_{CC1} = 12\text{V}$ ,  $V_{CC2} - V_{EE2} = 20\text{V}$ ,  $V_E - V_{EE2} = 0\text{V}$ .

Parameter	Symbol	Min.	Typ.	Max.	Units	Test Conditions	Fig.	Note
<b>Desaturation Protection (Desat voltage <math>V_{DESAT}</math> reference to <math>V_E</math>)</b>								
Desat Sensing Threshold	$V_{DESAT}$	6.2	7.0	7.8	V		16	8
Desat Charging Current	$I_{CHG}$	-1.2	-0.9	-0.6	mA	$V_{DESAT} = 2\text{V}$	17	
Desat Discharging Current	$I_{DSCHG}$	20	53		mA	$V_{DESAT} = 8\text{V}$	18	
Internal Desat Blanking Time	$t_{DESAT(BLANKING)}$	0.3	0.6	1.0	$\mu\text{s}$	$C_{SSD} = 1\text{ nF}$		22
Desat Sense to 90% SSD Delay	$t_{DESAT(90\%)}$		0.3		$\mu\text{s}$			23
Desat Sense to 10% SSD Delay	$t_{DESAT(10\%)}$		0.8		$\mu\text{s}$			24
Desat to Low Level /FAULT Signal Delay	$t_{DESAT(/FAULT)}$			7.0	$\mu\text{s}$			25
Output Mute Time due to Desat	$t_{DESAT(MUTE)}$	2.3	3.2	4.1	ms			26
Time for Input Kept Low Before Fault Reset to High	$t_{DESAT(RESET)}$	2.3	3.2	4.1	ms			27

## Package Characteristics

Parameter	Symbol	Min.	Typ.	Max.	Units	Test Conditions	Notes
Input-Output Momentary Withstand Voltage	$V_{ISO}$	5000			$V_{RMS}$	$RH < 50\%$ , $t = 1\text{ min.}$ $T_A = 25^\circ\text{C}$	28, 29, 30
Resistance (Input-Output)	$R_{I-O}$		$10^{14}$		$\Omega$	$V_{I-O} = 500\text{ V}_{DC}$	30
Capacitance (Input-Output)	$C_{I-O}$		1.3		pF	$f = 1\text{ MHz}$	
Thermal coefficient between LED and input IC	$A_{EI}$		35.4		$^\circ\text{C/W}$		
Thermal coefficient between LED and output IC	$A_{EO}$		33.1		$^\circ\text{C/W}$		
Thermal coefficient between input IC and output IC	$A_{IO}$		25.6		$^\circ\text{C/W}$		
Thermal coefficient between LED and Ambient	$A_{EA}$		176.1		$^\circ\text{C/W}$		
Thermal coefficient between input IC and Ambient	$A_{IA}$		92		$^\circ\text{C/W}$		
Thermal coefficient between output IC and Ambient	$A_{OA}$		76.7		$^\circ\text{C/W}$		

Notes:

1. Output IC power dissipation is derated linearly above 100°C from 580 mW to 260 mW at 125°C.
2. This supply is optional. Required only when negative gate drive is implemented.
3. Maximum pulse width = 1  $\mu$ s, maximum duty cycle = 1%.
4. Maximum 500 ns pulse width if peak  $V_{DESAT} > 10$  V.
5. 15V is the recommended minimum operating positive supply voltage ( $V_{CC2} - V_E$ ) to ensure adequate margin in excess of the maximum  $V_{UVLO+}$  threshold of 13.5V.
6. For High-Level Output Voltage testing,  $V_{OH}$  is measured with a DC-load current. When driving capacitive loads,  $V_{OH}$  approaches  $V_{CC}$  as  $I_{OH}$  approaches zero.
7. Maximum pulse width = 1.0 ms, maximum duty cycle = 20%.
8. Once  $V_{OUT}$  of the ACPL-344JT is allowed to go high ( $V_{CC2} - V_E > V_{UVLO}$ ), the DESAT detection feature of the ACPL-344JT will be the primary source of IGBT protection. UVLO is required to ensure DESAT is functional. Once  $V_{CC2}$  exceeds  $V_{UVLO+}$  threshold, DESAT remains functional until  $V_{CC2}$  is below the  $V_{UVLO}$  threshold. Thus, the DESAT detection and UVLO features of the ACPL-344JT work in conjunction to ensure constant IGBT protection.
9.  $t_{PLH}$  is defined as the propagation delay from 50% of LED input  $I_F$  to 50% of High-level output.
10.  $t_{PHL}$  is defined as the propagation delay from 50% of LED input  $I_F$  to 50% of Low-level output.
11. Pulse Width Distortion (PWD) is defined as ( $t_{PHL} - t_{PLH}$ ) of any given unit.
12. As measured from  $I_F$  to  $V_O$ .
13. Dead Time Distortion (DTD) is defined as ( $t_{PLH} - t_{PHL}$ ) between any two ACPL-344JT parts under the same test conditions.
14. Common-mode transient immunity in the high state is the maximum tolerable  $dV_{CM}/dt$  of the common-mode pulse,  $V_{CM}$ , to assure that the output remains in a high state (meaning  $V_O > 15V$ ).
15. Common-mode transient immunity in the low state is the maximum tolerable  $dV_{CM}/dt$  of the common-mode pulse,  $V_{CM}$ , to assure that the output remains in a low state (meaning  $V_O < 1.0V$ ).
16. The "increasing" (meaning turn-on or "positive going" direction) of  $V_{CC2} - V_E$ .
17. The "decreasing" (meaning turn-off or "negative going" direction) of  $V_{CC2} - V_E$ .
18. The delay time when  $V_{CC2}$  exceeds UVLO+ threshold to UVLO High – 50% of UVLO positive-going edge.
19. The delay time when  $V_{CC2}$  falls below UVLO– threshold to UVLO Low – 50% of UVLO negative-going edge.
20. The delay time when  $V_{CC2}$  exceeds UVLO+ threshold to 50% of High-level output.
21. The delay time when  $V_{CC2}$  falls below UVLO– threshold to 50% of Low-level output.
22. The delay time for ACPL-344JT to respond to a DESAT fault condition without any external DESAT capacitor.
23. The amount of time from when DESAT threshold is exceeded to 90% of  $V_{GATE}$  at mentioned test conditions.
24. The amount of time from when DESAT threshold is exceeded to 10% of  $V_{GATE}$  at mentioned test conditions.
25. The amount of time from when DESAT threshold is exceeded to FAULT output Low – 50% of  $V_{CC1}$  voltage.
26. The amount of time when DESAT threshold is exceeded, Output is mute to LED input.
27. The amount of time when DESAT Mute time is expired, LED input must be kept LOW for Fault status to return to HIGH.
28. In accordance with UL1577, each optocoupler is proof tested by applying an insulation test voltage  $\geq 6000V_{RMS}$  for 1 second.
29. The Input-Output Momentary Withstand Voltage is a dielectric voltage rating that should not be interpreted as an input-output continuous-voltage rating. For the continuous-voltage rating, refer to your equipment level safety specification or IEC/EN/DIN EN 60747-5-5 Insulation Characteristics Table.
30. Device considered a two-terminal device: pins 1 through 8 are shorted together and pins 9 through 16 are shorted together.

Thermal Characteristics are based on the ground planes layout of the evaluation PCB, shown as follows:

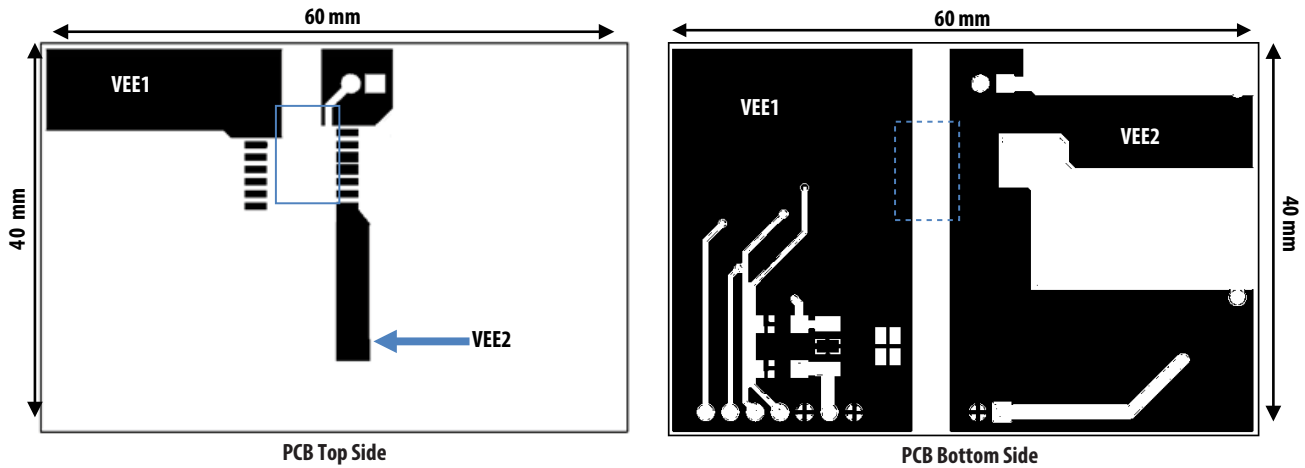

### Notes on Thermal Calculation

Application and environmental design for ACPL-344JT must ensure that the junction temperature of the internal ICs and LED within the gate driver optocoupler do not exceed 150°C. The following equations calculate the maximum power dissipation and its corresponding effect on junction temperatures.

$$\text{LED Junction Temperature} = (A_{EA} \times P_E) + (A_{EI} \times P_I) + (A_{EO} \times P_O) + T_A$$

$$\text{Input IC Junction Temperature} = (A_{EI} \times P_E) + (A_{IA} \times P_I) + (A_{IO} \times P_O) + T_A$$

$$\text{Output IC Junction Temperature} = (A_{EO} \times P_E) + (A_{IO} \times P_I) + (A_{OA} \times P_O) + T_A$$

$P_E$ —LED Power Dissipation

$P_I$ —Input IC Power Dissipation

$P_O$ —Output IC Power Dissipation

### Calculation of LED Power Dissipation

$$\text{LED Power Dissipation, } P_E = I_{F(\text{LED})} (\text{Recommended Max}) \times V_{F(\text{LED})} (125^\circ\text{C}) \times \text{Duty Cycle}$$

$$\text{Example: } P_E = 16 \text{ mA} \times 1.25 \times 50\% \text{ duty cycle} = 10 \text{ mW}$$

### Calculation of Input IC Power Dissipation

$$\text{Input IC Power Dissipation, } P_I = I_{CC1 (\text{Max})} \times V_{CC1} (\text{Recommended Max.})$$

$$\text{Example: } P_I = 6 \text{ mA} \times 18 \text{ V} = 108 \text{ mW}$$

### Calculation of Output IC Power Dissipation

Output IC Power Dissipation,  $P_O = V_{CC2}$  (Recommended Max.)  $\times I_{CC2}$  (Max.) +  $P_{HS}$  +  $P_{LS}$

$P_{HS}$ —High Side Switching Power Dissipation

$P_{LS}$ —Low Side Switching Power Dissipation

$$P_{HS} = (V_{CC2} \times Q_G \times f_{PWM}) \times R_{OH(MAX)} / (R_{OH(MAX)} + R_{GH}) / 2$$

$$P_{LS} = (V_{CC2} \times Q_G \times f_{PWM}) \times R_{OL(MAX)} / (R_{OL(MAX)} + R_{GL}) / 2$$

$Q_G$ —IGBT Gate Charge at Supply Voltage

$f_{PWM}$ —LED Switching Frequency

$R_{OH(MAX)}$ —Maximum High Side Output Impedance— $V_{OH(MIN)} / I_{OH(MIN)}$

$R_{GH}$ —Gate Charging Resistance

$R_{OL(MAX)}$ —Maximum Low Side Output Impedance— $V_{OL(MIN)} / I_{OL(MIN)}$

$R_{GL}$ —Gate Discharging Resistance

Example:

$$R_{OH(MAX)} = (V_{CC2} - V_{OH(MIN)}) / I_{OH(MIN)} = 3V / 0.75A = 4\Omega$$

$$R_{OL(MAX)} = V_{OL(MIN)} / I_{OL(MIN)} = 2.5V / 1A = 2.5\Omega$$

$$P_{HS} = (20V \times 1 \mu C \times 10 \text{ kHz}) \times 4\Omega / (4\Omega + 10\Omega) / 2 = 28.57 \text{ mW}$$

$$P_{LS} = (20V \times 1 \mu C \times 10 \text{ kHz}) \times 2.5\Omega / (2.5\Omega + 10\Omega) / 2 = 20 \text{ mW}$$

$$P_O = 20V \times 13.6 \text{ mA} + 28.57 \text{ mW} + 20 \text{ mW} = 320.57 \text{ mW}$$

### Calculation of Junction Temperature

$$\text{LED Junction Temperature} = 176.1 \text{ }^\circ\text{C/W} \times 10 \text{ mW} + 35.4 \text{ }^\circ\text{C/W} \times 108 \text{ mW} + 33.1 \times 320.57 \text{ mW} + T_A = 16.2^\circ\text{C} + T_A$$

$$\text{Input IC Junction Temperature} = 35.4 \text{ }^\circ\text{C/W} \times 10 \text{ mW} + 92 \text{ }^\circ\text{C/W} \times 108 \text{ mW} + 25.6 \times 320.57 \text{ mW} + T_A = 18.5^\circ\text{C} + T_A$$

$$\text{Output IC Junction Temperature} = 33.1 \text{ }^\circ\text{C/W} \times 10 \text{ mW} + 25.6 \text{ }^\circ\text{C/W} \times 108 \text{ mW} + 76.7 \times 320.57 \text{ mW} + T_A = 27.7^\circ\text{C} + T_A$$

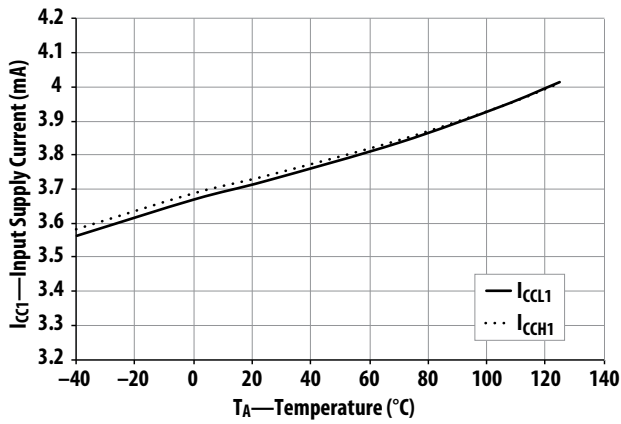

Figure 8.  $I_{CC1}$  Across Temperature.

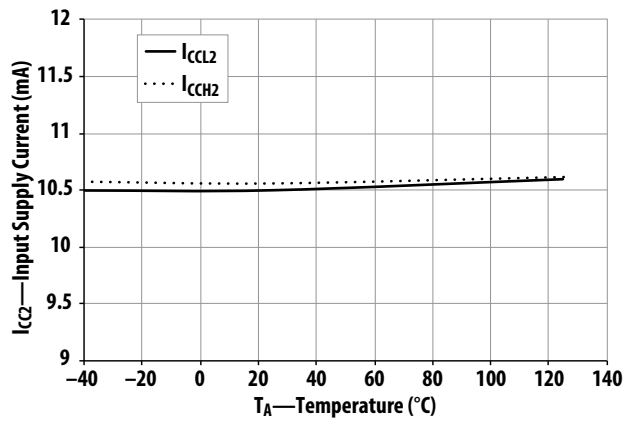

Figure 9.  $I_{CC2}$  Across Temperature.

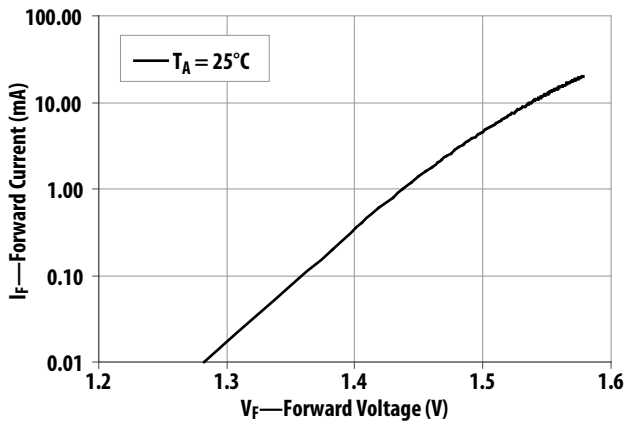

Figure 10.  $I_F$  vs.  $V_F$ .

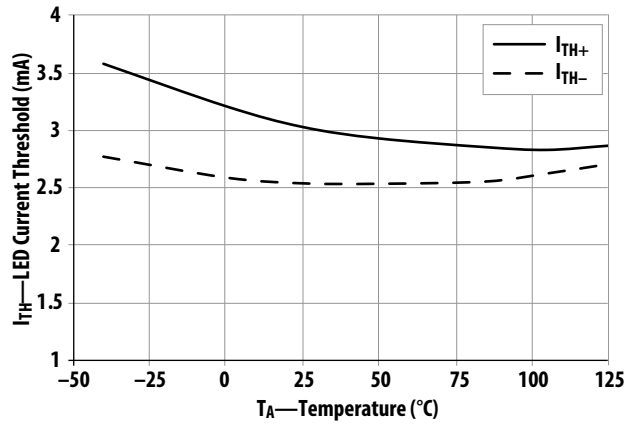

Figure 11.  $I_{TH}$  Across Temperature.

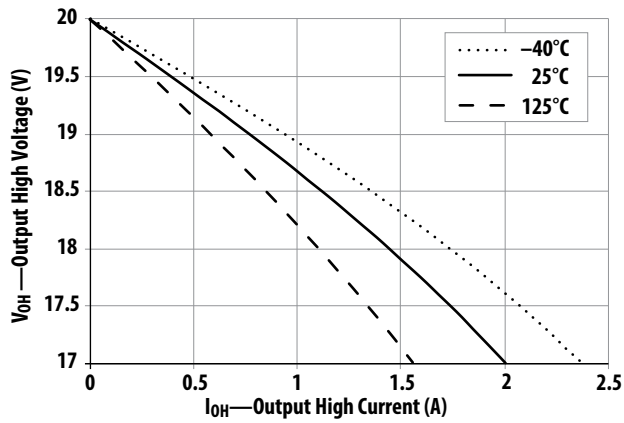

Figure 12.  $V_{OH}$  vs.  $I_{OH}$ .

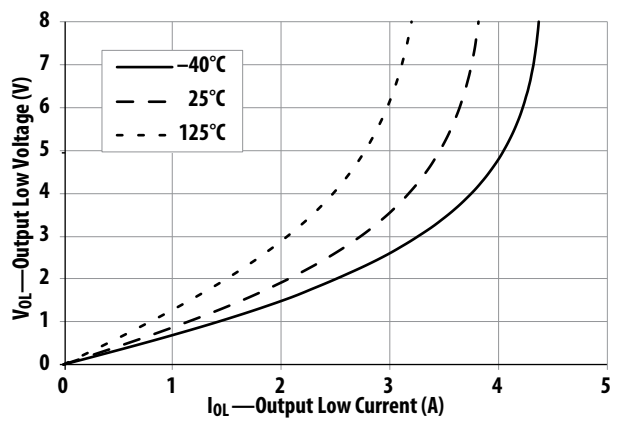

Figure 13.  $V_{OL}$  vs.  $I_{OL}$ .

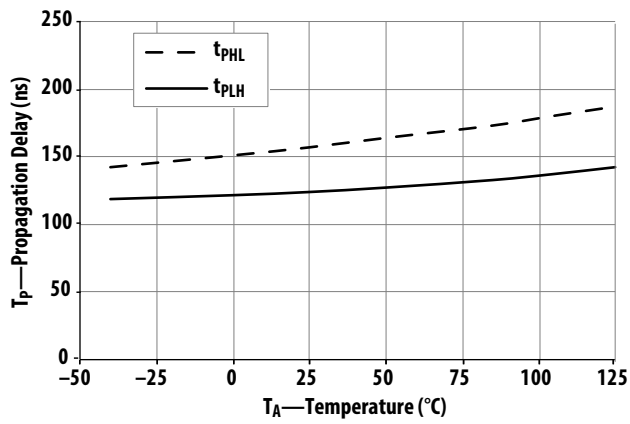

Figure 14.  $T_P$  Across Temperature.

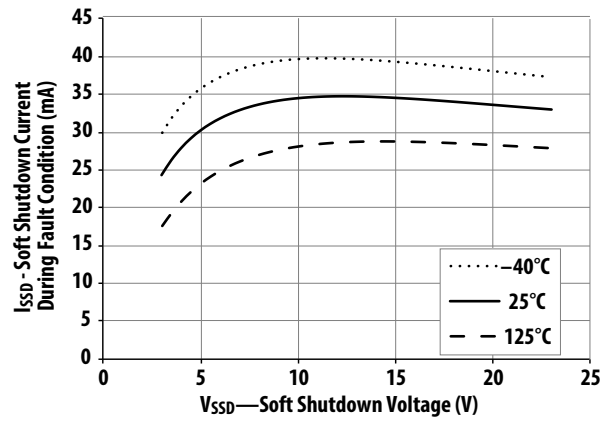

Figure 15.  $I_{SSD}$  vs.  $V_{SSD}$ .

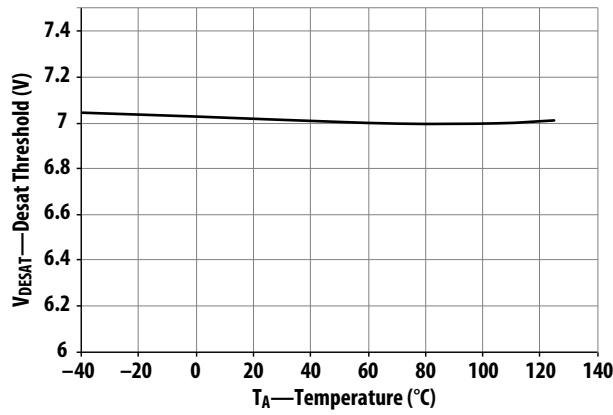

Figure 16.  $V_{DESAT}$  Threshold Across Temperature.

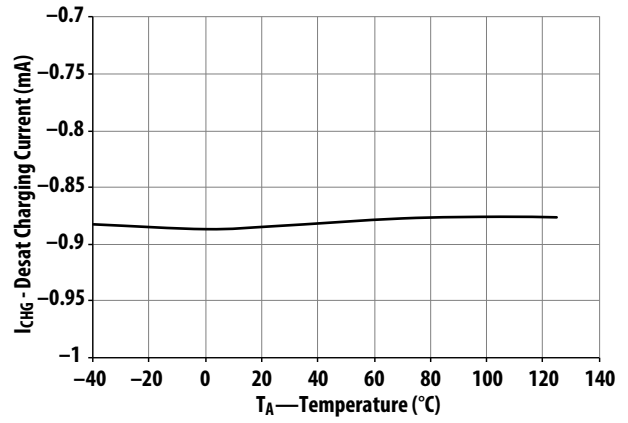

Figure 17.  $I_{CHG}$  Across Temperature.

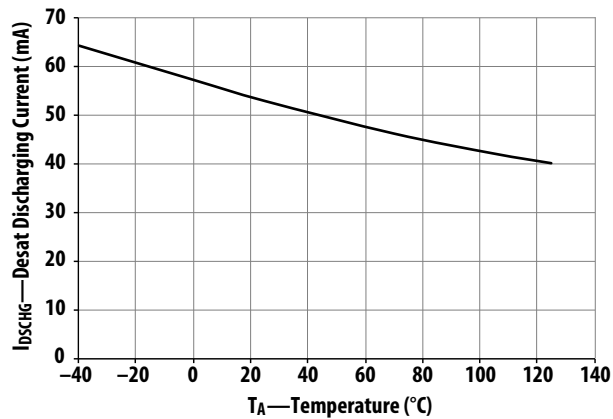

Figure 18.  $I_{DCHG}$  Across Temperature.