

EA2823QJ-T1000 EVK User's Guide

5V/3.4A Power Bank Solution

Description

This document supports the EA2823QJ-T1000 Evaluation Kit. This evaluation kit is a proven application-circuit design for the ACT2823QJ-T1000 dual cell charger with power path and single USB output. The EVK contains a single micro-USB input and USB output. It provides a 3.3A output. It is configured to charge a 2s Lithium-Ion battery at 1.0A. The EVK operates with a very high charge efficiency of 96% and discharge efficiency of 95.6%. The EA2823QJ-T1000 EVK ships with the ACT2823QJ-T1000 IC, which has an 8.4V EOC (end of charge voltage). The ACT2823QJ-T1435 IC can be evaluated on this EVK by simply replacing the IC.

Demo Board Photos

(DEMO BOARD SIZE: 48mm*31mm)

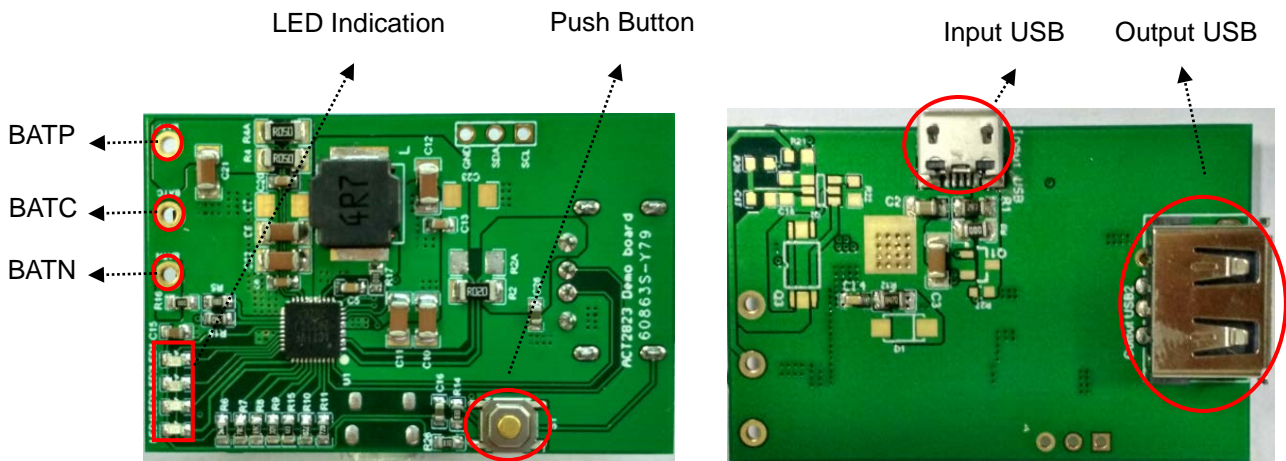

PCB Layout

TOP Layer

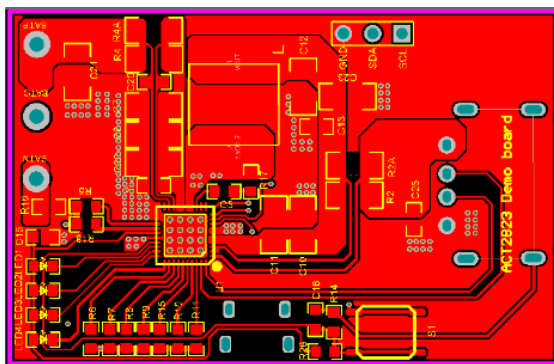

Bottom Layer

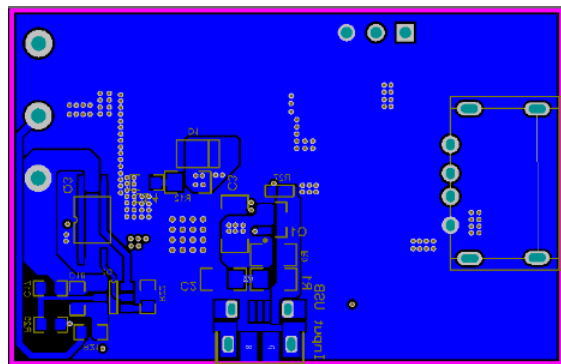

Functional Test

Battery Charge V/I Profile

Vbat(V)	0	1.0	3.0	5.0	5.2	5.4	5.6	5.7	6.0	7.0	8.0	8.25	8.3	8.38
Charge Current(mA)	0	40	40	156	157	156	155	1032	1038	1039	1047	1048	722	0

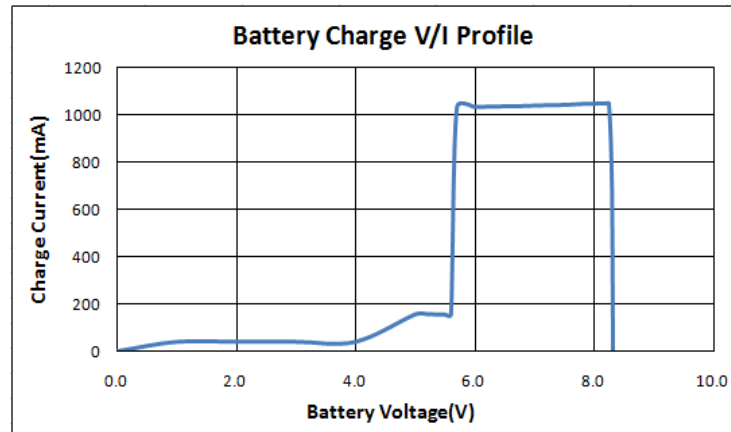

Power Path Function

(Test condition: Vin=5.05V, Vbat=7V, input current limit=3.8A, fast charge current=1.0A)

Input current(mA)	1467	1679	1977	2264	2481	2697	2991	3258	3450	3463	3455	3470	2743
Output current(mA)	0	200	500	800	1000	1200	1500	1800	1950	2000	2200	2600	2728
Charge current(mA)	1015	1012	1010	1009	1007	1006	1012	1009	1002	973	840	583	0

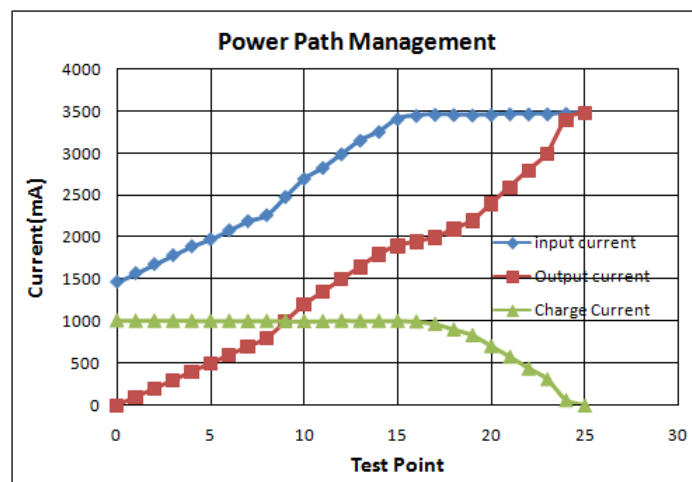

Charge Efficiency

(Vin=5V and charge current set at 1000mA)

Battery voltage (V)	6.0	6.5	7.0	7.5	8.0	8.2
Efficiency (%)	95.9	95.3	94.1	93.1	92.1	91.7

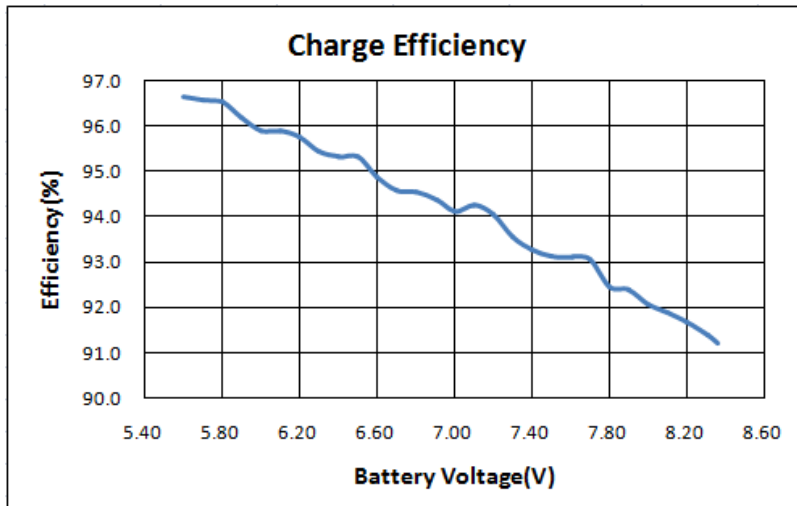

Buck Efficiency and Power Loss (Ta=25°C)

Vbat	Efficiency (%)						
	Io=500mA	Io=1000mA	Io=1500mA	Io=2000mA	Io=2400mA	Io=3000mA	Io=3300mA
6.0V	96.2	95.7	94.7	93.6	92.8	91.3	90.6
7.0V	95.5	95.5	94.6	93.5	92.7	91.5	90.5
8.4V	94.2	94.5	94.0	93.0	92.4	91.0	90.4

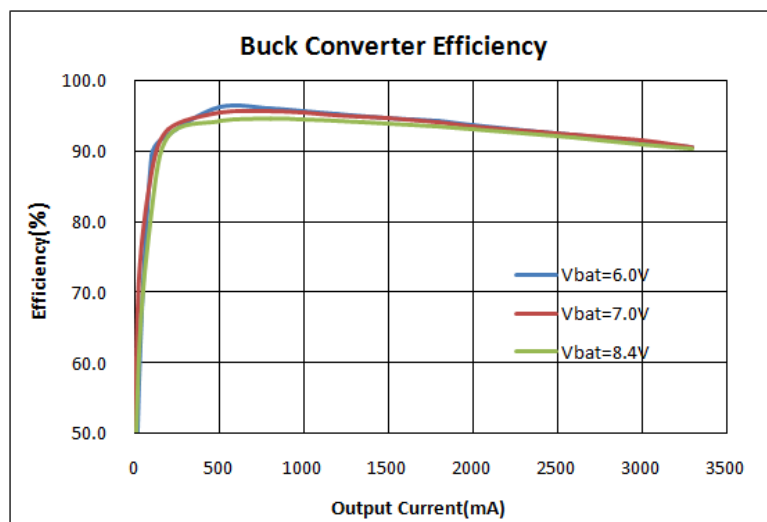

Vbat	Power Loss (W)						
	Io=500mA	Io=1000mA	Io=1500mA	Io=2000mA	Io=2400mA	Io=3000mA	Io=3300mA
6.0V	0.10	0.23	0.42	0.68	0.93	1.43	1.71
7.0V	0.12	0.24	0.43	0.69	0.94	1.38	1.72
8.4V	0.16	0.29	0.48	0.75	0.99	1.48	1.75

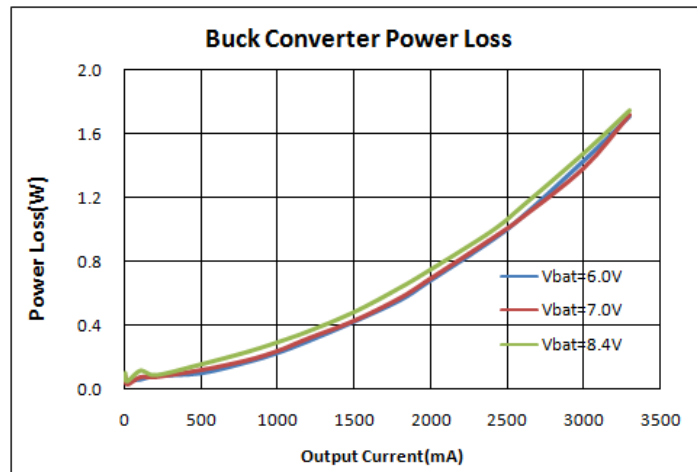

Buck Constant Current and Constant Voltage Regulation (Ta=25°C)s

	Vbat=6.0V		Vbat=7.0V		Vbat=8.0V	
	Vout(V)	Iout(mA)	Vout (V)	Iout(mA)	Vout(V)	Iout(mA)
CC Load	5.20	0	5.20	0	5.20	0
	5.08	12	5.08	12	5.08	12
	5.04	1000	5.03	1000	5.03	1000
	5.01	2000	5.01	2000	5.01	2000
	4.98	3000	4.98	3000	4.98	3000
	4.97	3300	4.97	3300	4.97	3300
CV Load	4.95	3361	4.95	3363	4.95	3363
	4.9	3361	4.9	3362	4.9	3362
	4.7	3362	4.7	3362	4.7	3362
	4.5	3361	4.5	3361	4.5	3361
	4.3	3361	4.3	3362	4.3	3362
	4.0	3362	4.0	3361	4.0	3361
	3.8	3362	3.8	3361	3.8	3361
	3.6	3362	3.6	3361	3.6	3361
3.55	0	3.55	0	3.55	0	

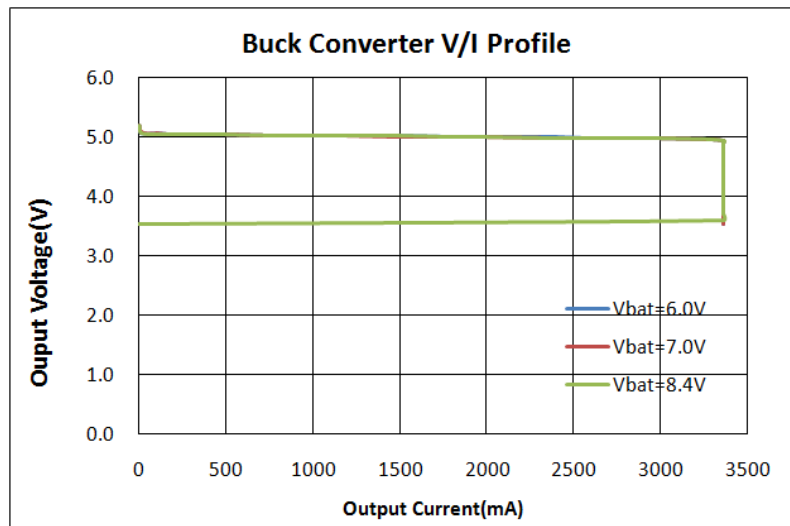

Battery Leakage Current in HZ Mode

Test Conditions	Battery Input Current (μA)	Power Loss (μW)
Vbat=6V	2.5	15
Vbat=7V	2.6	18.2
Vbat=8V	2.8	22.4
Vbat=8.4V	3.1	26

Ripple and Noise

Ripple & noise are measured by using 20MHz bandwidth limited oscilloscope.

Test Conditions	Output Ripple at 2.4A Load (mV)	Output Ripple at 3.3A Load (mV)
Vbat=6.0V	45	50
Vbat=7.0V	40	50
Vbat=8.4V	40	45

Load Dynamic Response Load Step

(Output=80mA-1A-80mA load step)

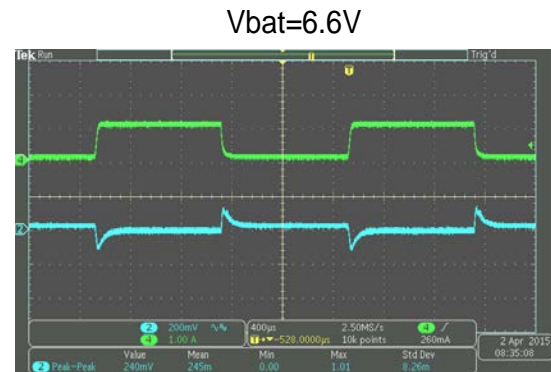
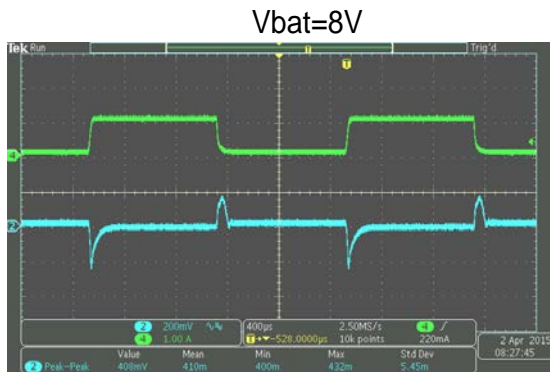

(Output=1A-2.4A-1A load step)

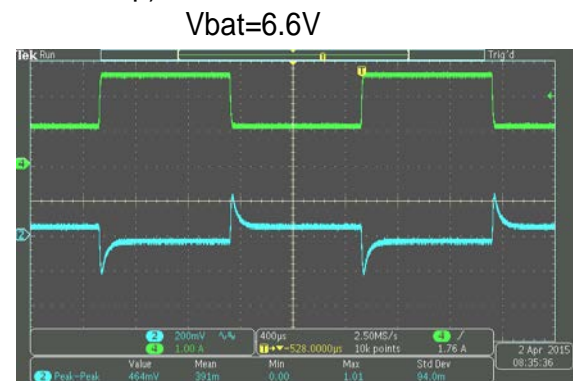
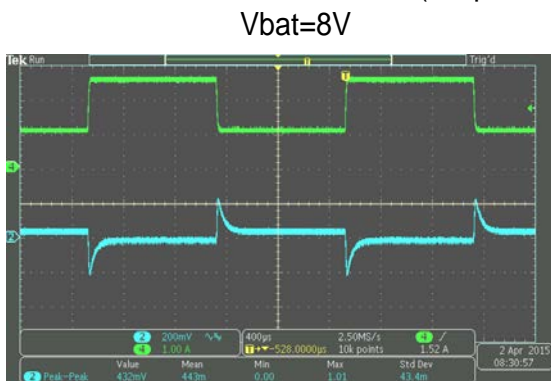
LED Indication

Conventional LED indication

PB time>40ms (HZ Mode)	LED1	LED2	LED3	LED4
$V_{BAT} < V_{cut-off}$	Off	Off	Off	Off
$V_{cut-off} \leq V_{BAT} < V_{LED1}$	Flash	Off	Off	Off
$V_{LED1} \leq V_{BAT} < V_{LED2}$	On	Off	Off	Off
$V_{LED2} \leq V_{BAT} < V_{LED3}$	On	On	Off	Off
$V_{LED3} \leq V_{BAT} < V_{LED4}$	On	On	On	Off
$V_{BAT} \geq V_{LED4}$	On	On	On	On

Charge Mode	LED1	LED2	LED3	LED4
$V_{BAT} < V_{LED2}$	Flash	Off	Off	Off
$V_{LED2} \leq V_{BAT} < V_{LED3}$	On	Flash	Off	Off
$V_{LED3} \leq V_{BAT} < V_{LED4}$	On	On	Flash	Off
$V_{LED4} \leq V_{BAT}$ Charge Mode	On	On	On	Flash
$V_{LED4} \leq V_{BAT}$ EOC Mode	On	On	On	On

ACT2823 is designed with a simple ADC to convert 5 levels of PT pin voltage into 5 application patterns.

INDICATION PATTERN	PT Resistor
Conventional Always On In Discharge	R15=3.3K
Conventional 5s Indication in Discharge	R15=12K
Breathing 5s Indication in Discharge	R15=24K
Bottom Charging 5s Indication in Discharge	R15=42K
Circulating 5s Indication in Discharge	R15=68K

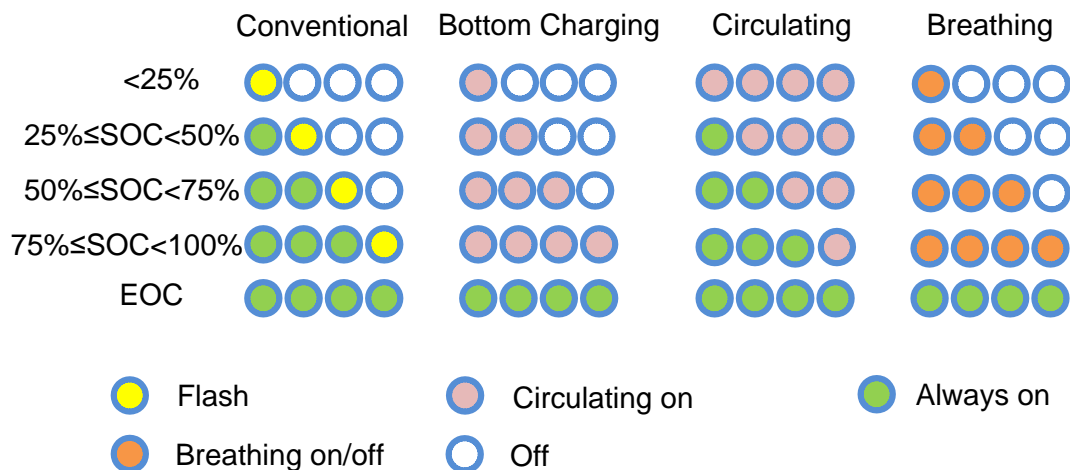

System Management

- PB is pressed for >5s or Discharge load is <10mA for 12.5s, Discharge mode is go into HZ mode
- PB is pressed for 40ms, Discharge mode is turned on
- PB is pressed for 40ms, LED indication is on for 5.0 seconds
- 2 seconds transition time between Charge Mode and Boost Mode

Key Components Temperature Test (Ta=25C, burning for 2 hours)

Charge mode, 1.0A charge current

Vin(V)	IC(°C)	Inductor(°C)	Vbat(V)
5.0	36.5	34.3	6
5.0	45.4	41.8	7.5
5.0	51.6	46.6	8.2

Discharge mode, 3.3A output current

Vbat(V)	IC(°C)	Inductor(°C)	Vout(V)
6	67.3	60	5.0
7.5	75.6	63.8	5.0
8.2	77.5	66.1	5.0

EMI Test

Vbat=7.8V, Output: 5V/3.3A Horizontal

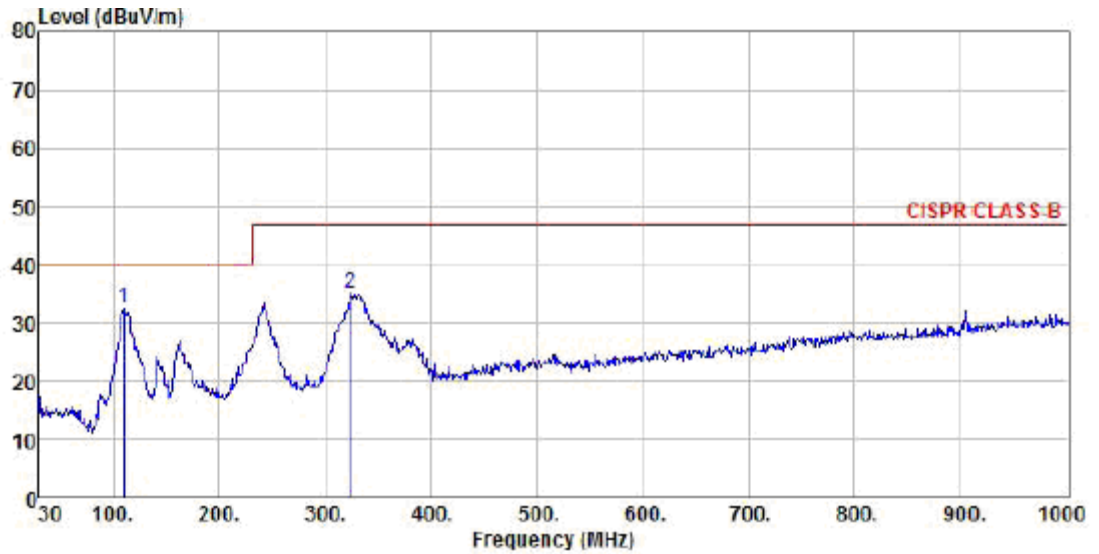

Site : chamber
 Condition : CISPR CLASS-B 3m VULB9160 HORIZONTAL
 EUT :
 Model Name : ACT2823
 Temp/Humi : 21 °C / 50 %
 Power Rating:
 Mode : 5V/2.4A
 Memo :

	Freq	ReadAntenna Level	Cable Factor	Preamp Loss	Factor	Limit Level	Over Line	Remark
	MHz	dBuV	dB/m	dB	dB	dBuV/m	dBuV/m	dB
1 pp	109.54	20.11	11.07	1.41	0.00	32.59	40.00	-7.41 Peak
2	323.91	18.84	13.74	2.51	0.00	35.09	47.00	-11.91 Peak

Vbat=7.8V, Output: 5V/3.3A Vertical

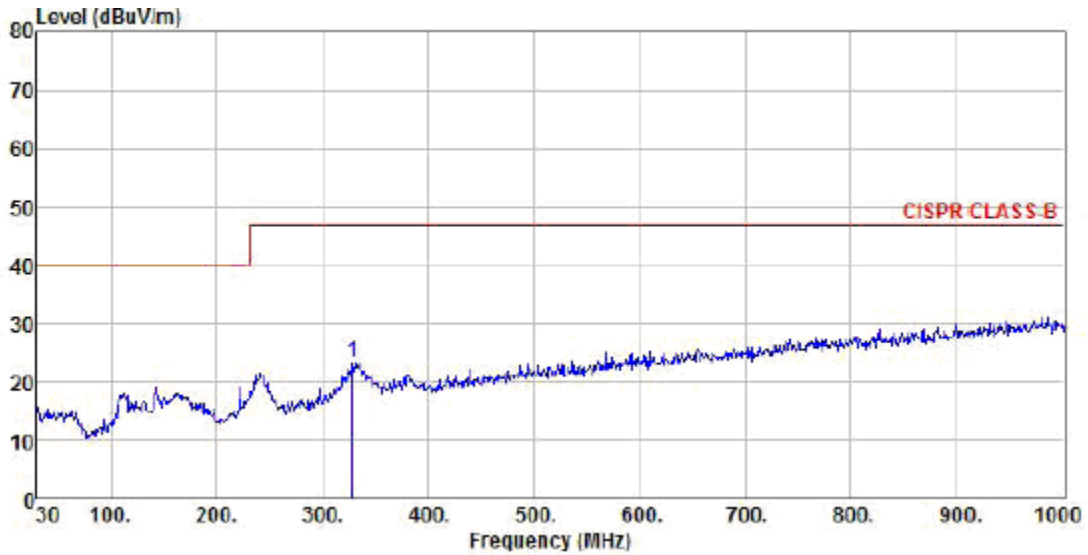

Site : chamber
 Condition : CISPR CLASS-B 3m VULB9160 VERTICAL
 EUT :
 Model Name : ACT2823
 Temp/Humi : 21 °C / 50 %
 Power Rating:
 Mode : 5V/2.4A
 Memo :

	ReadAntenna	Cable	Preamp		Limit	Over	
Freq	Level	Factor	Loss	Factor	Level	Line	Limit
MHz	dBuV	dB/m	dB	dB	dBuV/m	dBuV/m	dB
1 pp 328.76	7.09	13.87	2.48	0.00	23.44	47.00	-23.56 Peak

SCHEMATICS

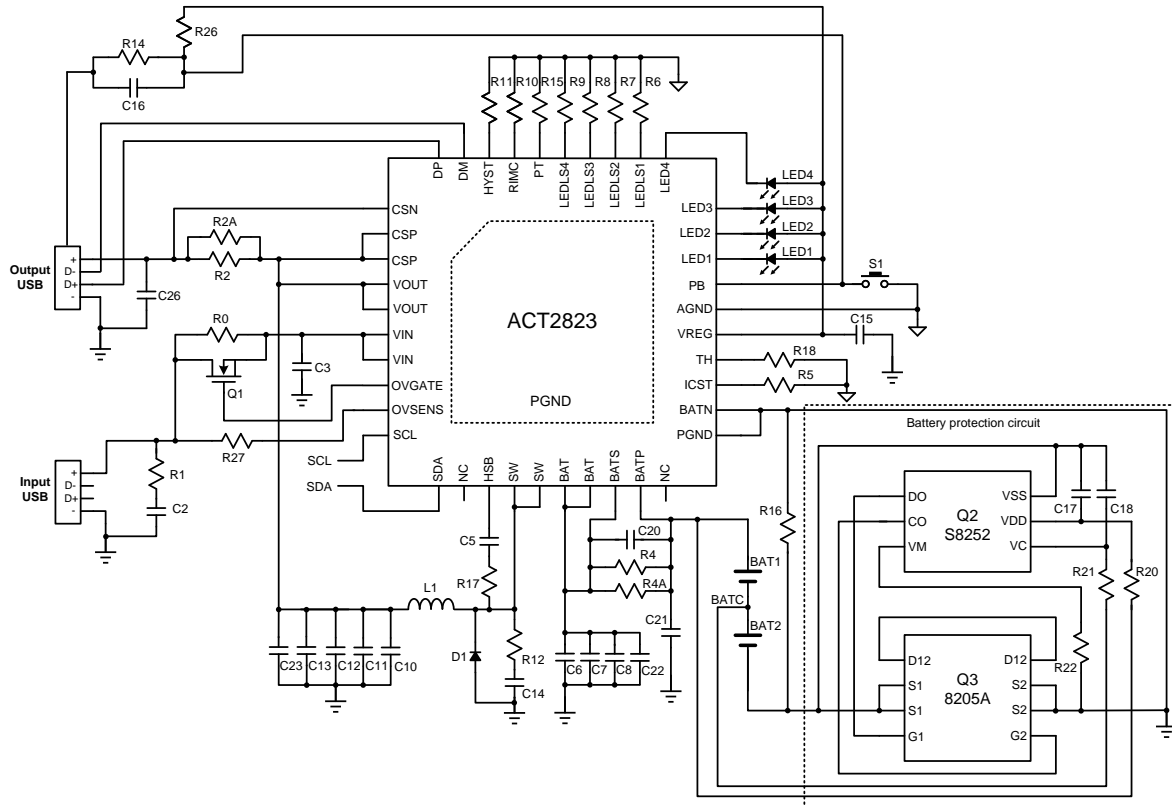

Application information

Charge Current Setting:

$$I_c(A) = \frac{200}{R_{cs}(m\Omega) \times R_{icst}(K\Omega)}$$

LED Indication:

MODE	TRIG	LED1	LED2	LED3	LED4
CHARGE	HIGH	$V_{LED1} + V_{IMC} + 0.6 * V_{HYST}$	$V_{LED2} + V_{IMC} + 0.6 * V_{HYST}$	$V_{LED3} + V_{IMC} + 0.6 * V_{HYST}$	$V_{LED4} + V_{IMC} + 0.6 * V_{HYST}$
	LOW	$V_{LED1} + V_{IMC} - 100mV$	$V_{LED2} + V_{IMC} - 100mV$	$V_{LED3} + V_{IMC} - 100mV$	$V_{LED4} + V_{IMC} - 100mV$
DIS-CHARGE	HIGH	$V_{LED1} - V_{IMC} + 100mV$	$V_{LED2} - V_{IMC} + 100mV$	$V_{LED3} - V_{IMC} + 100mV$	$V_{LED4} - V_{IMC} + 100mV$
	LOW	$V_{LED1} - V_{IMC} - 0.6 * V_{HYST}$	$V_{LED2} - V_{IMC} - 0.6 * V_{HYST}$	$V_{LED3} - V_{IMC} - 0.6 * V_{HYST}$	$V_{LED4} - V_{IMC} - 0.6 * V_{HYST}$

$$V_{LED(x)}(A) = 5.5V + \frac{108K}{R_{LS(x)}(K\Omega)}$$

$$V_{IMC}(V) = 2106K * I_{BAT}(A) * \frac{R_{CS}(\Omega)}{R_{IMC}(K\Omega)}$$

$$V_{HYST(4:3)} = \frac{54K}{R_{HYST}(K\Omega)}$$

Innovative Power™

ActiveSwitcher™ is a trademark of Active-Semi.

Bill of Materials

Item	Reference	Description	Qty	Manufacturer
1	C2	Ceramic capacitor, 4.7uF/10V, X7R, 0805	1	Murata/TKD
2	C3, C8, C10, C11, C12, C21, C22	Ceramic capacitor, 22uF/16V, X7R, 1206	7	Murata/TKD
3	C5	Ceramic capacitor, 47nF/16V, X7R, 0603	1	Murata/TKD
4	C6, C13	Ceramic capacitor, 0.1uF/16V, X7R, 0603	2	Murata/TKD
5	C14	Ceramic capacitor, 2.2nF/10V, X7R, 0603	1	Murata/TKD
6	C15	Ceramic capacitor, 1uF/10V, X7R, 0603	1	Murata/TKD
7	C16	Ceramic capacitor, 2.2uF/10V, X7R, 0603	1	Murata/TKD
8	C17, C18	Ceramic capacitor, 0.22uF/16V, X7R, 0603, DNP	0	Murata/TKD
9	C20	Ceramic capacitor, 100nF/10V, X7R, 0603	1	Murata/TKD
10	C7, C23	Ceramic capacitor, 22uF/16V, X7R, 1206, DNP	0	Murata/TKD
11	C26	Ceramic capacitor, 3.3uF/10V, X7R, 0603	1	Murata/TKD
12	D1	MBR1020VL, 20V/1A Schottky, SMA, DNP	0	Panjit
13	L1	SWPA8040S4R7NT 4.7uH 5.9A(8*8*4mm)	1	Sunlord
14	LED1, LED2, LED3, LED4	LED, 0603, Blue	4	LED Manu
15	Micro-USB	MICRO USB 5P/F SMT B	1	
16	Output USB	10.2*14.6*7mm,4P	1	
17	Q1	AO3400A, N-MOSFET, DNP	0	AOS
18	Q2	2S Battery protection IC, S8252, DNP	0	Seiko
19	Q3	N-MOSFET, 8205A, DNP	0	Fortune
20	R0	Chip Resistor, 0Ω, 1/8W, 5%, 0805	1	Murata/TKD
21	R1	Chip Resistor, 2.7Ω, 1/8W, 5%, 0805	1	Murata/TKD
22	R2	Chip Resistor, 20mΩ, 1/2W, 0.5%, 1206	1	SART
23	R2A	Chip Resistor, 1/2W, 0.5%, 1206, DNP	0	SART
24	R4, R4A	Chip Resistor, 50mΩ, 1/2W, 0.5%, 1206	2	SART
25	R5	Chip Resistor, 8kΩ, 1/10W, 1%, 0603	1	Murata/TKD
26	R6	Chip Resistor, 83kΩ, 1/10W, 1%, 0603	1	Murata/TKD
27	R7	Chip Resistor, 63.5kΩ, 1/10W, 1%, 0603	1	Murata/TKD
28	R8	Chip Resistor, 51.4kΩ, 1/10W, 1%, 0603	1	Murata/TKD
29	R9	Chip Resistor, 41.5kΩ, 1/10W, 1%, 0603	1	Murata/TKD
30	R10, R11	Chip Resistor, 540kΩ, 1/10W, 1%, 0603	2	Murata/TKD
31	R12	Chip Resistor, 0.47Ω, 1/8W, 1%, 0805	1	Murata/TKD
32	R14, R26	Chip Resistor, 715K, 1/10W, 5%, 0603	2	Murata/TKD