

ACT41000EVK1-104 User's Guide

Description

This document describes the characteristics and operation of the Qorvo ACT41000EVK1-104 evaluation kit (EVK). It provides setup and operation instructions, schematic, layout, BOM, and test data. This EVK demonstrates the ACT41000-104T power management IC. Other ACT41000Qlxxx options can be evaluated on this EVK by replacing the IC and any other necessary components.

Features

The EVK can be used as a standalone board if desired. However, to access the internal registers and to take full advantage of the IC's capability, the user must connect the EVK to a PC with Qorvo's USB-TO-I2C interface dongle and use the GUI software. The EVK provides full access to each converter's input and output voltage, as well as all the digital control signals. This gives the user the flexibility to configure the EVK to match their real-world system



Figure 1. EVK Picture

EVK Contents

The ACT41000EVK1-104 evaluation kit comes with the following items:

- EVK assembly
- USB-TO-I2C dongle
- Dongle
- Custom 4-pin connector that connects the USB-TO-I2C dongle to the EVK assembly

Required Equipment

- ACT41000EVK1-104
- USB-TO-I2C Dongle
- Power supply - 24~40V @ 5A for full power operation
- Oscilloscope - 100MHz, 4 channels
- Digital Multi-meters (DMM)
- Windows compatible PC with spare USB port.

Hardware Setup

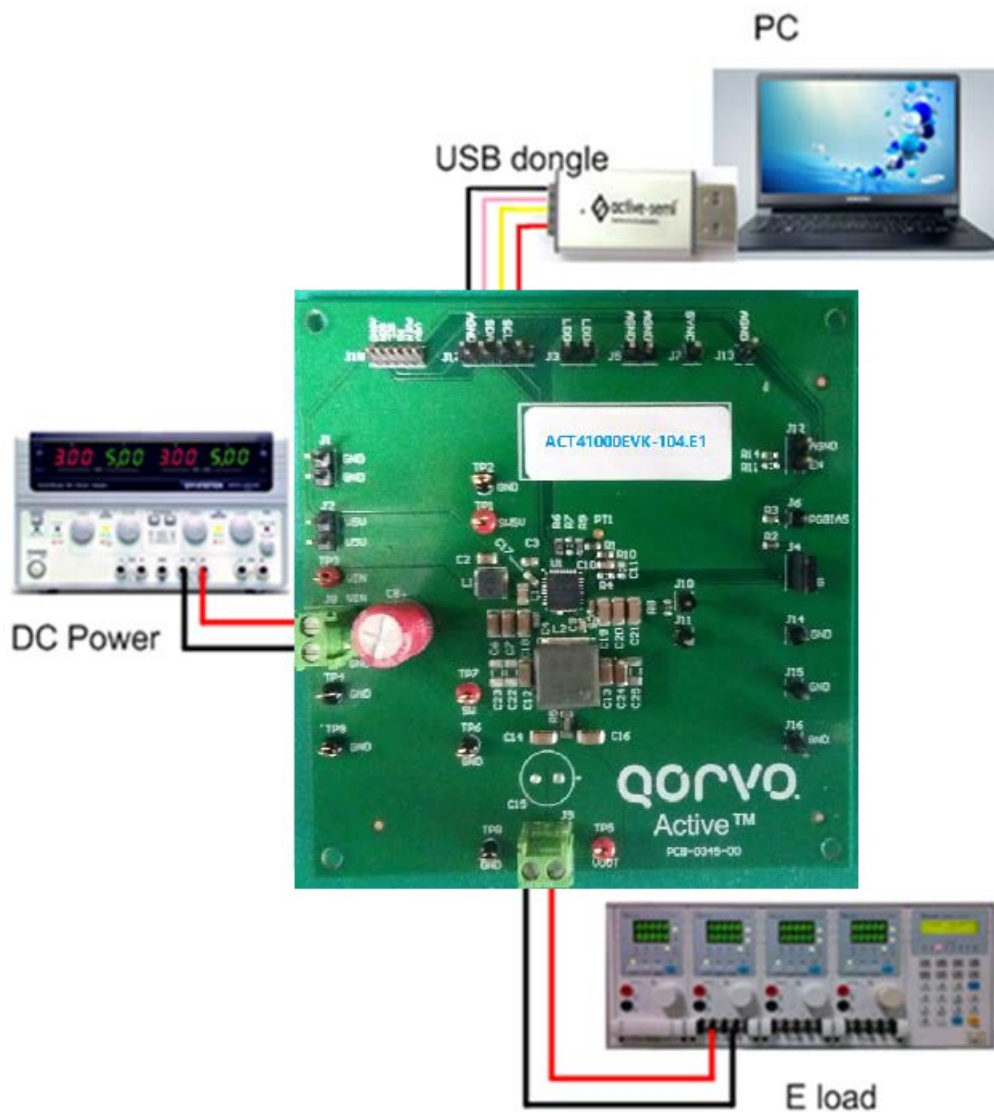

Figure 2. EVK Setup

Quick Start

Hardware Connections

Refer to Figure 2 for hardware connections.

1. Connect a DC power supply to J8. J8 is connector for input voltage (VIN). Please ensure the correct power supply polarity.
2. Connect an E-Load to J9. J9 is connector for output voltage (VOOUT).
3. Connect Digital Multi-Meters to VIN and VOOUT to monitor the input voltage and output voltages.
4. Add a digital Multi-Meter in series with VIN and VOOUT if you want to observe input and output current.
5. Be careful to keep the input voltage within the specifications.
6. Optional – Connect the EVK to the PC with the USB dongle.

GUI Setup (optional)

1. Refer to the end of this document for detailed instructions to install the ACT41000 GUI.
2. Connect the USB-TO-I2C dongle to the computer via a USB cable.
3. Connect the USB-TO-I2C dongle to the EVK J17 connector. Refer to Figure 3 to ensure the correct polarity of the connection. As a guide, use the “Active-Semi” (or Qorvo) logo on the top of the dongle so the black wire is connected to the Dongle GND pin.

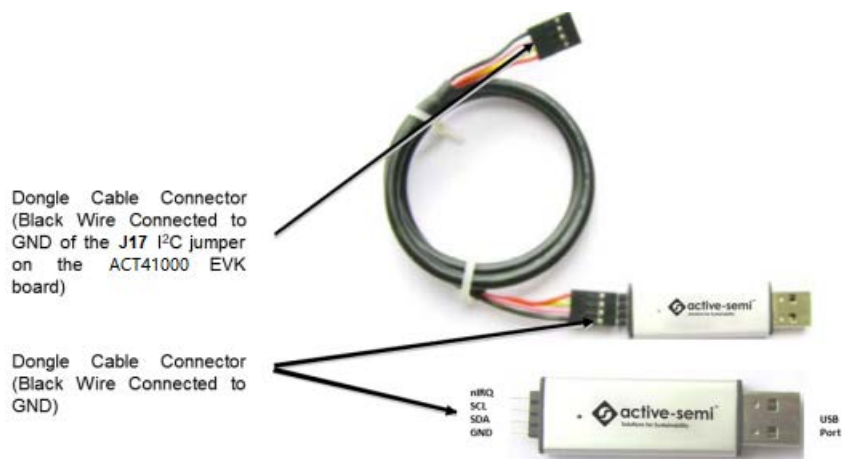

Figure 3. USB-TO-I2C Dongle Connection

Recommended Operating Conditions

The ACT41000EVK1-104 is designed for a 24V-40V input voltage. The maximum operating voltage is determined by the IC's maximum input voltage rating. The minimum operating voltage is determined by the IC's output voltage setting. The ACT41000-104T output voltage is 22V, so the EVK should be operated with V_{in} greater than 22V. The maximum output current is configured by the CMI and external components. The switching frequency is set to 450kHz to optimize efficiency. The customer can easily reconfigure the EVK for different switching frequencies and output voltages after referring to the datasheet for the required component changes. The output voltage can be changed via I²C either before or after the output voltage is enabled.

Table 1. Recommended Operating Conditions

Parameter	Description	Min	Typ	Max	Unit
VIN	Input voltage	24	-	40	V
VOUT	Main-buck output voltage	3	-	22	V
V5V	Mini-buck output voltage		5		V
I _{V5V_max}	Mini-buck maximum output current		300		mA
I _{out_max}	Main-buck maximum output current		4		A

EVK Operation

Turn On the Evaluation Board

After the power source and E-Load are connected to the evaluation board per the required connections, the EVK can be powered for operation. Perform the following steps to turn on the board.

1. Ensure that the power supply connected to VIN (J8) is >24V and <40V.
2. Turn on power supply.
3. Apply the load.
4. Remove the shorting jumper from J12 to enable output. Replace the jumper to disable the output.

Output Current Limit – The ACT41000EVK1-104 output current limit is set to 4A. This is a function of the 20mΩ current sense resistor (R5), the 16kΩ ILIM resistor (R9), and the I²C Output Current Limit bits, which are set to 100uA by default. The ACT41000 integrates a digital-to-analog converter (ILIM DAC) for the purpose of generating the reference signal used by the Current Limit block. The ILIM DAC generates an output current at the ILIM pin. The output current limit is easily changed by modifying any of these three parameters. The easiest way to change the output current limit is with the ILIM DAC field in the GUI.

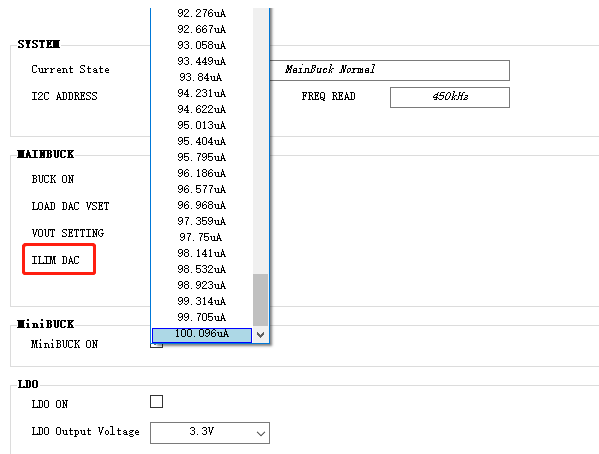

Output Voltage Setting

The default output voltage can be changed by I²C using the VOUT SETTING field in the GUI. Refer to the ACT41000 datasheet before changing the output voltage. Large output voltage changes from the default setting may require changes in external components to ensure optimized performance.

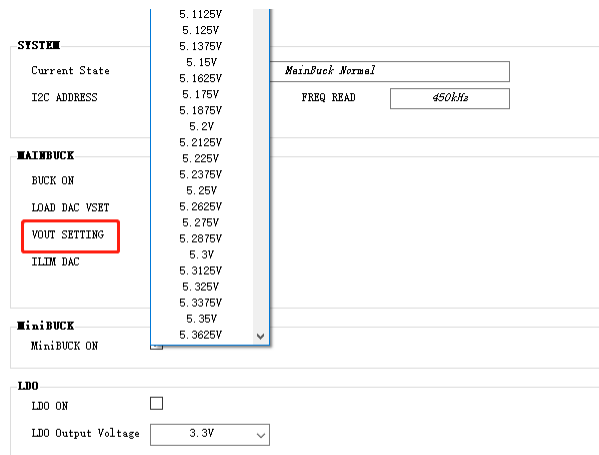

Additional Programmable Functionality

The ACT41000 contains many additional programmable parameters. Refer to the ACT41000 datasheet for additional functionality and default I²C register values.

Test Results

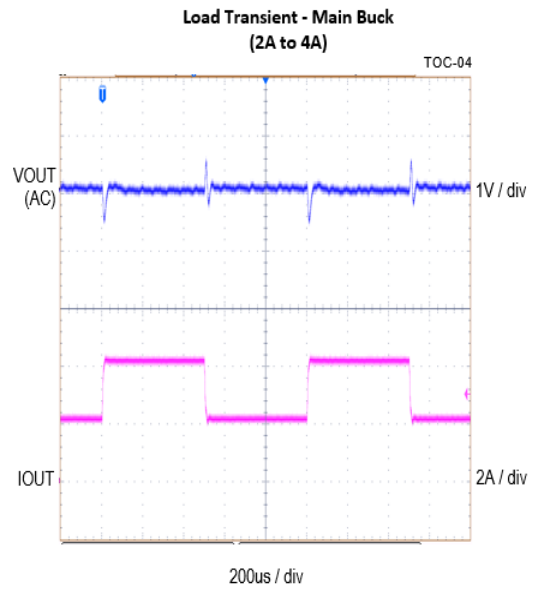
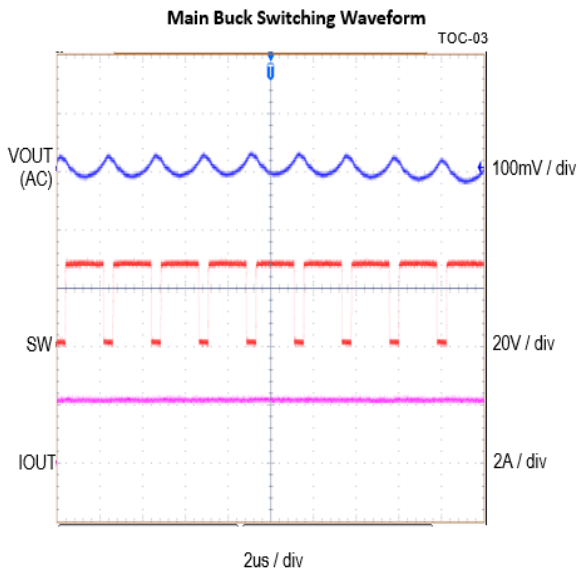
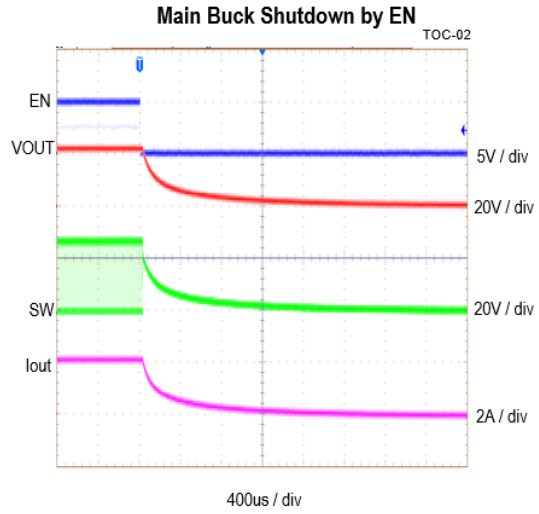
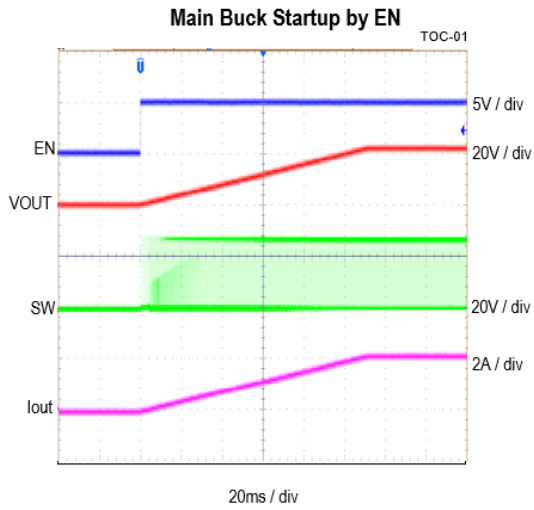

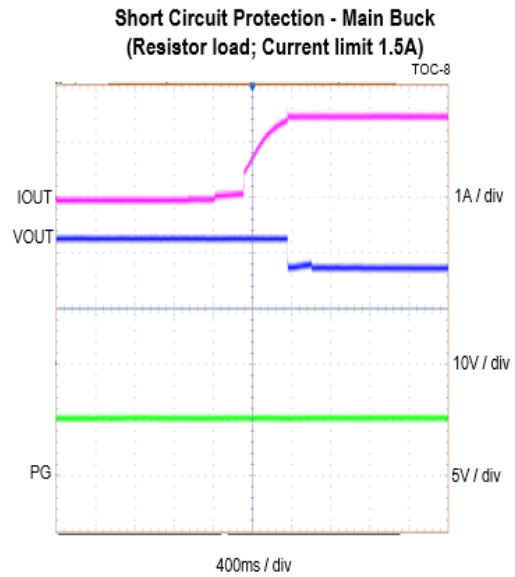
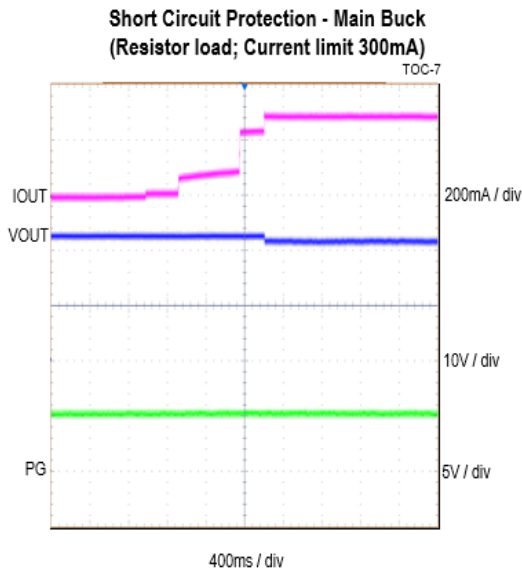
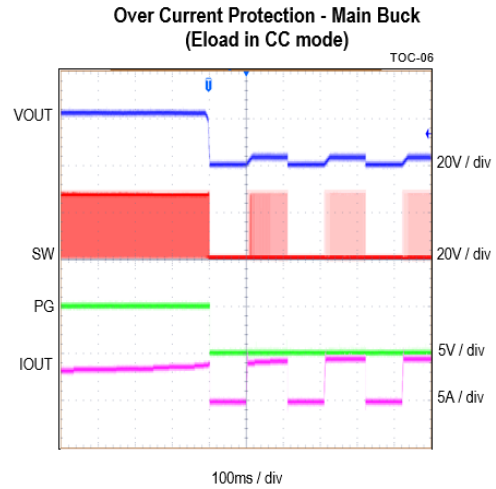
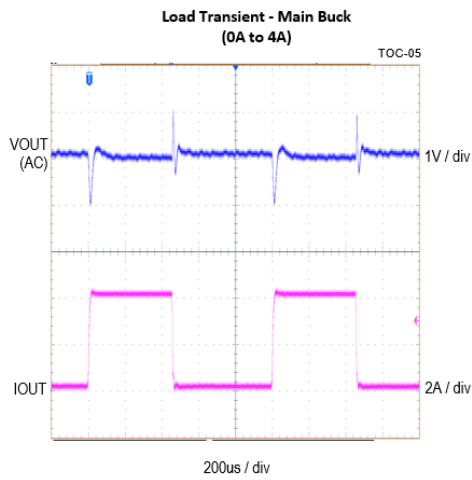

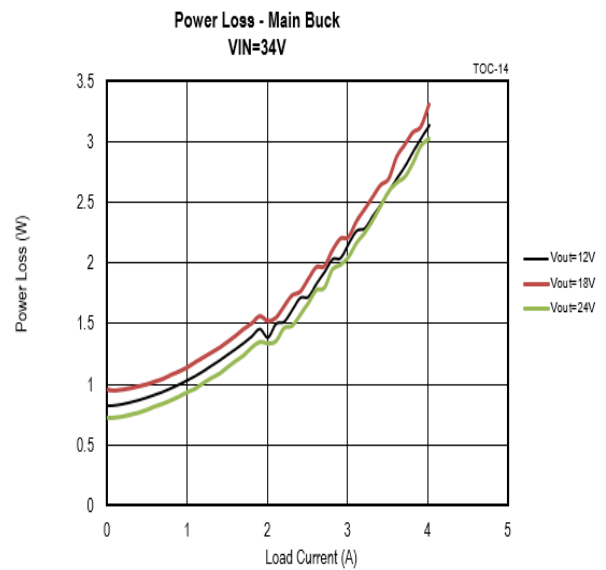
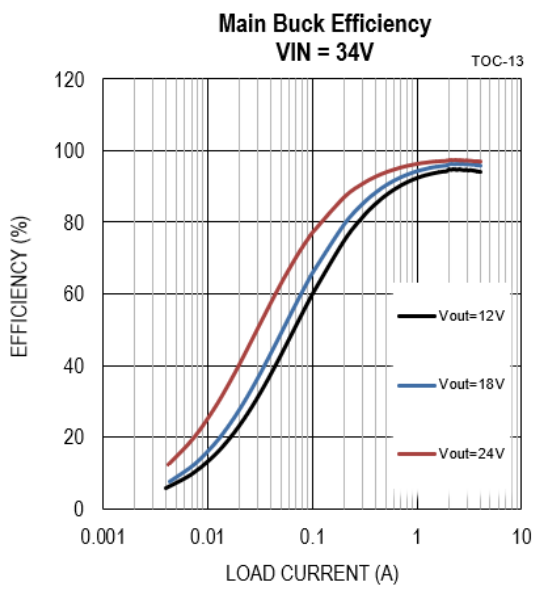
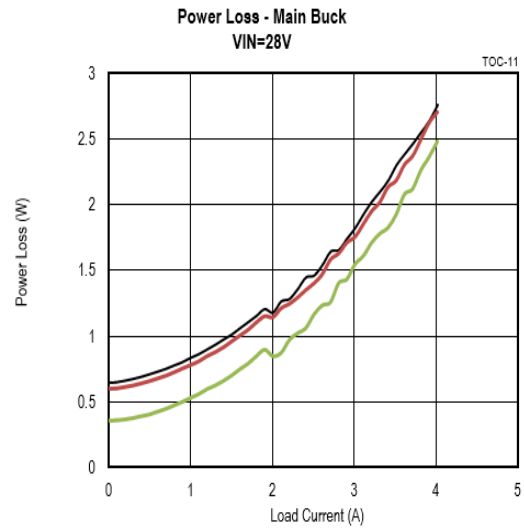
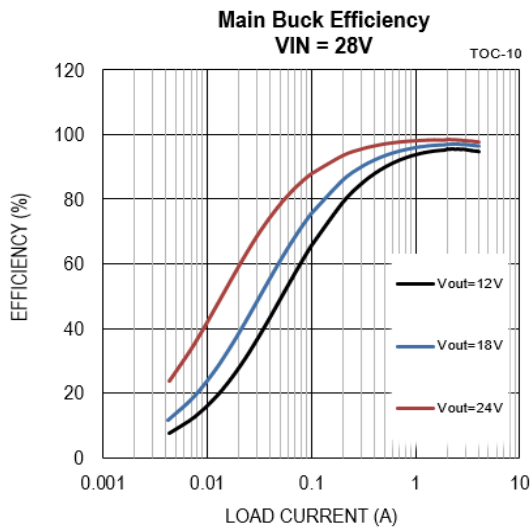

Schematic

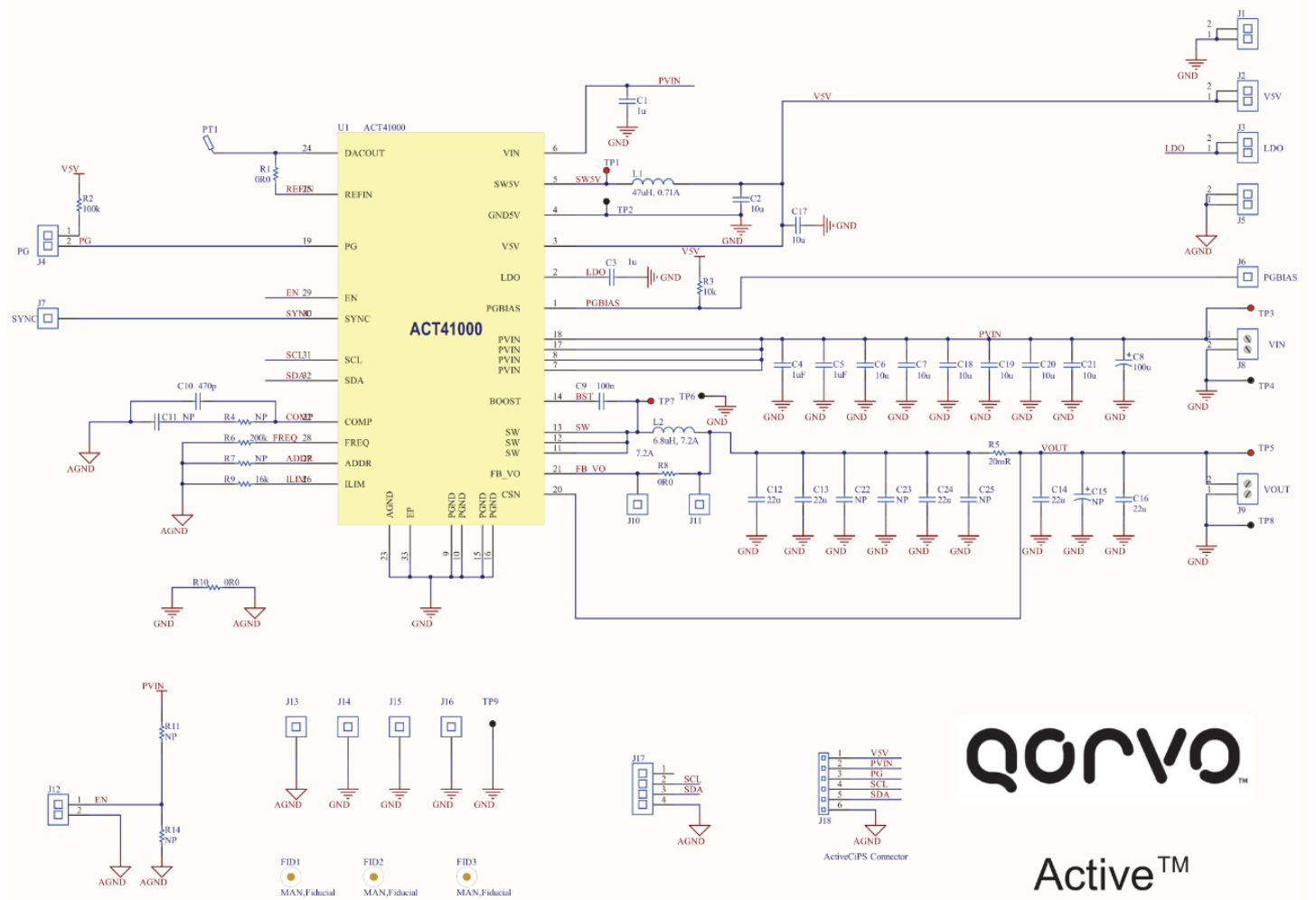

Figure 4. Schematic

Layout

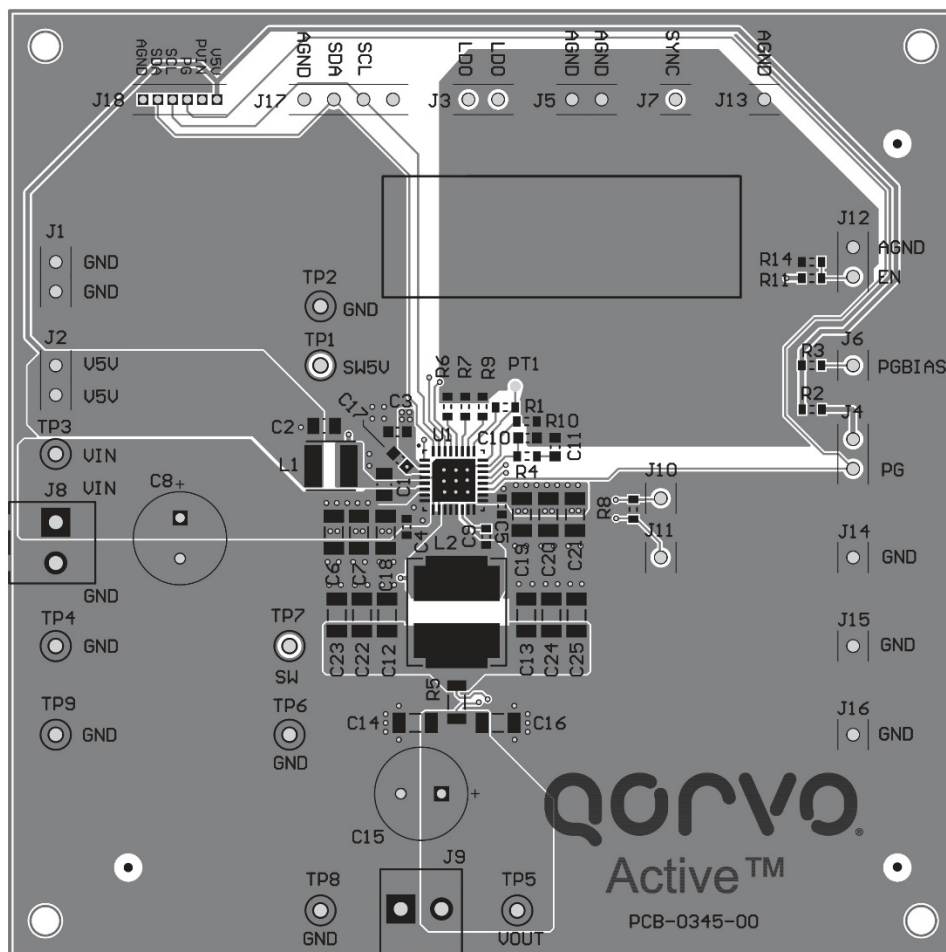

Figure 5. Layout Top Layer

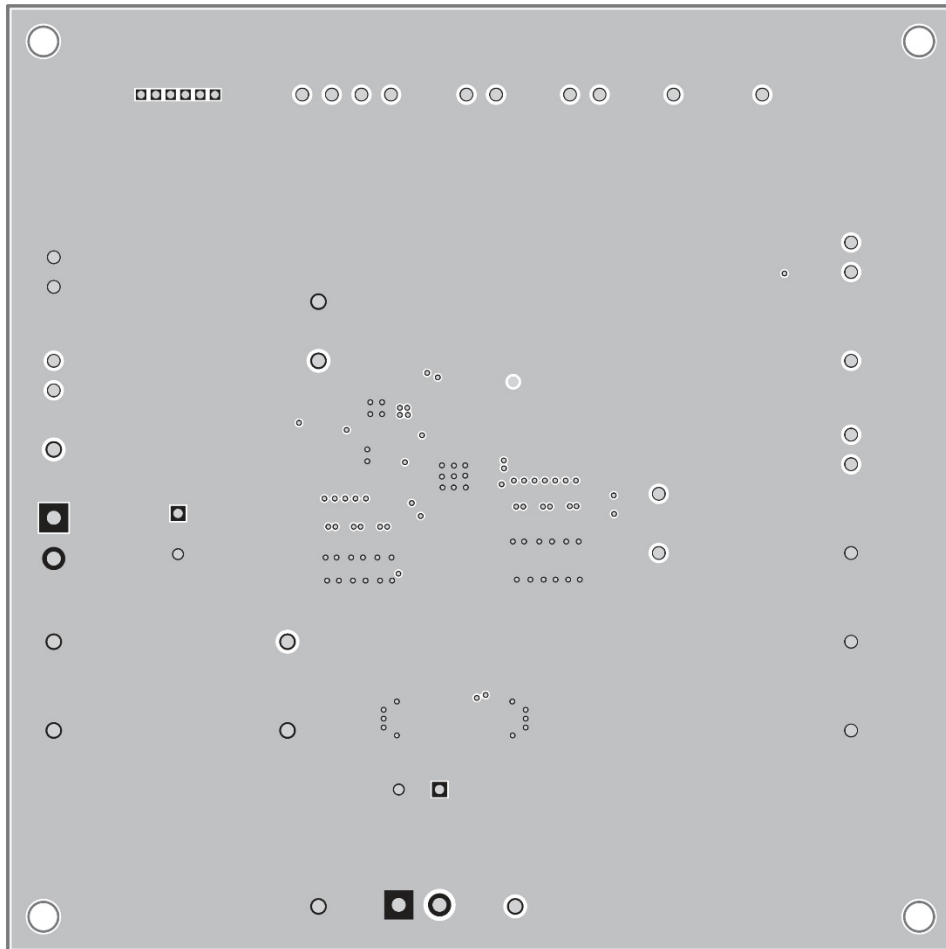

Figure 6. Layout Layer 2 - GND

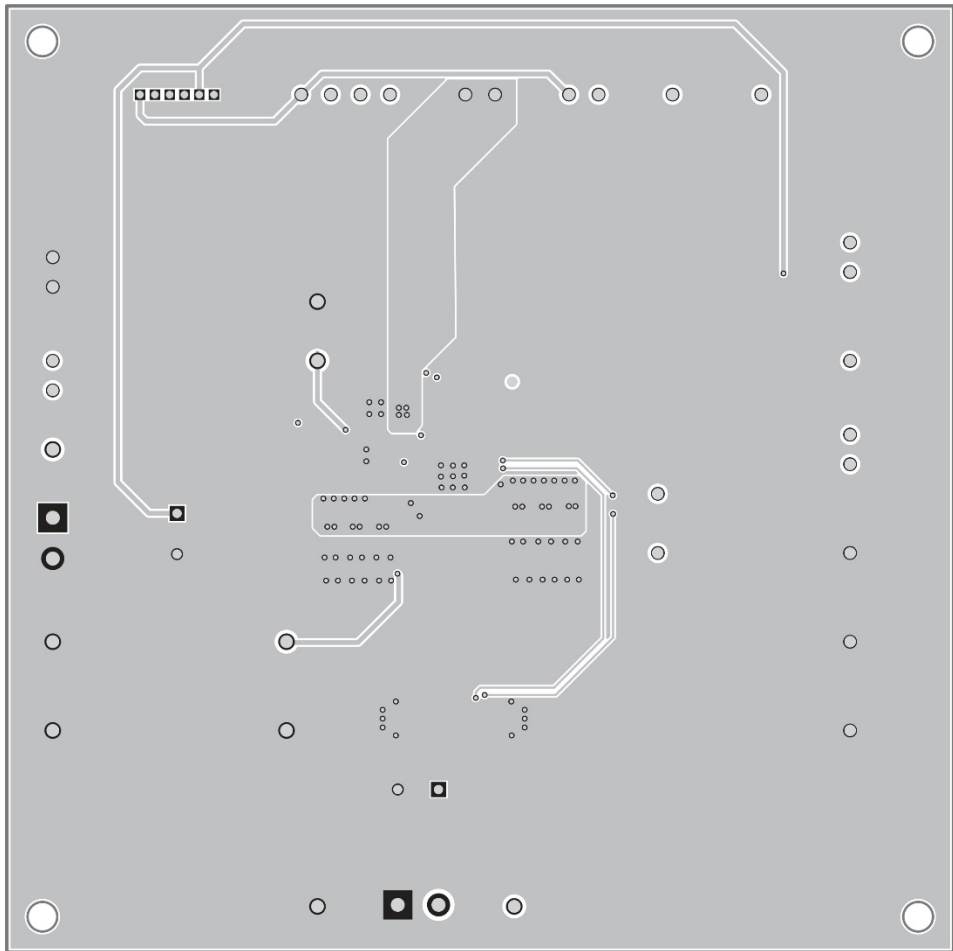

Figure 7. Layout Layer 3 -VCC

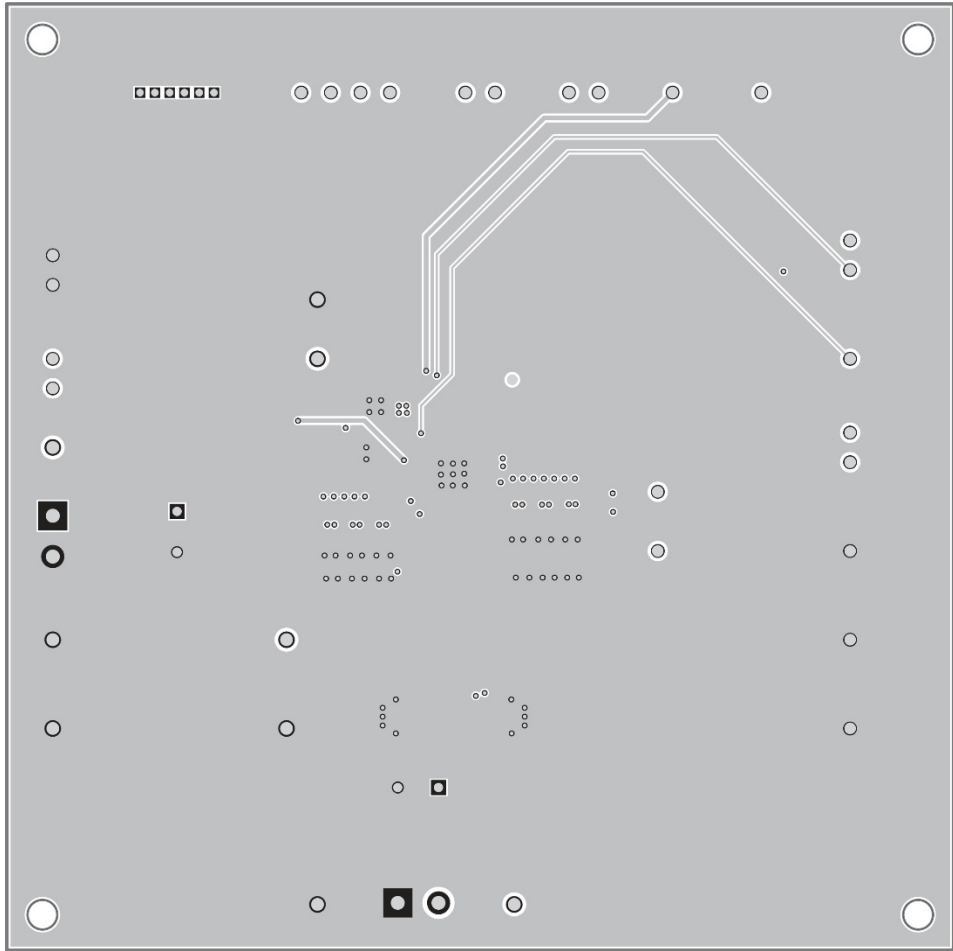

Figure 8. Layout Bottom Layer

Bill of Materials

Table 2. ACT41000EVK1-104 BOM

Item	Ref Des	QTY	Description	Package	MFR	Part Number
1	C1	1	Cap, Ceramic, 1uF, 50V, 20%, X5R	0805	std	std
2	C2	1	Cap, Ceramic, 10uF, 10V, 20%, X5R	0805	Wurth Elektronik	885012107010
3	C3	1	Cap, Ceramic, 1uF, 10V, 20%, X5R	0603	std	std
4	C4, C5	2	Cap, Ceramic, 1uF, 50V, 20%, X5R	0603	std	std
5	C6, C7, C18, C19, C20, C21	6	Cap, Ceramic, 10uF, 50V, 10%, X5R	1206	TDK	CGA5L3X5R1H106K160AB
6	C8	1	Cap, Aluminium Electrolytic, 100uF, 50V	8x11.5mm	Wurth Elektronik	860010674014
7	C9	1	Cap, Ceramic, 100nF, 25V, 20%, X5R	0603	std	std
8	C10	1	Cap, Ceramic, 470pF, 50V, 20%, X5R	0603	std	std
9	C11	0	NP	0603	std	std
10	C12, C13, C14, C16, C24	5	Cap, Ceramic, 22uF, 35V, 20%, X5R	1206	TDK	C3216X5R1V226M160AC
11	C15	0	NP	8x11.5mm	Wurth Elektronik	860010674014
12	C17	1	Cap, Ceramic, 10uF, 25V, 10%, X5R	0603	std	std
13	C22, C23, C25	0	NP	1206	TDK	C3216X5R1V226M160AC
14	J1, J2, J3, J4, J5, J12	6	Header, 2pin, 100mil		std	std
15	J6, J7, J10, J11, J13, J14, J15, J16	8	Header, 1pin, 100mil		std	std
16	J8, J9	2	Entry modular, 2pin		Wurth Elektronik	691214110002S
17	J17	1	Header, 4 pin, 100mil		std	std
18	J18	1	Header, Unshrouded , 1.27, Male, 6P		Sullins	GRPB061VWVN-RC
19	L1	1	Inductor, 47uH, 0.71A, SMD	4mmx4mm	Wurth Elektronik	74404043470A
20	L2	1	Inductor, 6.8uH, 7.2A , SMD	8.0mmx9.0mm	Wurth Elektronik	74439358068
21	R1, R8, R10	3	Res, 0Ω, 1%	0603	std	std
22	R2,	1	Res, 100kΩ, 1%	0603	std	std
23	R3	1	Res, 10kΩ, 1%	0603	std	std

24	R4	0	NP	0603	std	std
25	R7, R11, R14	0	NP	0603	std	std
26	R5	1	Resistor, 20mΩ, 1%, 1W	1206	SART	SMF12MAFR020T
27	R6	1	Res, 200kΩ, 1%	0603	std	std
28	R9	1	Res, 16kΩ, 1%	0603	std	std
29	TP1, TP3, TP5, TP7	4	Test Point, Red		Keystone	TESTPOINT 5000
30	TP2, TP4, TP6, TP8, TP9	5	Test Point, Black		Keystone	TESTPOINT 5001
31	U1	1	ACT41000	QFN32-5X5	Qorvo	ACT41000-104T
32	--	1	Multi-Jumper, 100mil		std	std
33	--	1	PCB, ACT41000EVK	n/a	n/a	PCB-0345-00

GUI Installation

1. Get GUI files from the Qorvo website
2. Plug the USB-TO-I2C dongle into a free USB port.
3. Follow the instructions in the “How to install driver for dongle” folder.
4. Double click on the ActiveGUI.exe to start the ACT41000 GUI.

GUI Overview

The GUI has 2 basic function buttons allocated in top-left of the Tool Bar which are Read and Write I²C. The GUI contains 2 setting modes: Basic Mode and Advanced Mode. In Basic Mode screen it displays basic user programmable configuration options are programmed using the drop-down boxes or check boxes. Advanced Mode contains the button text for changing setting for every single bit.

Basic Mode

The following figure shows the GUI in basic mode. This mode allows the user to easily change one or more IC settings.

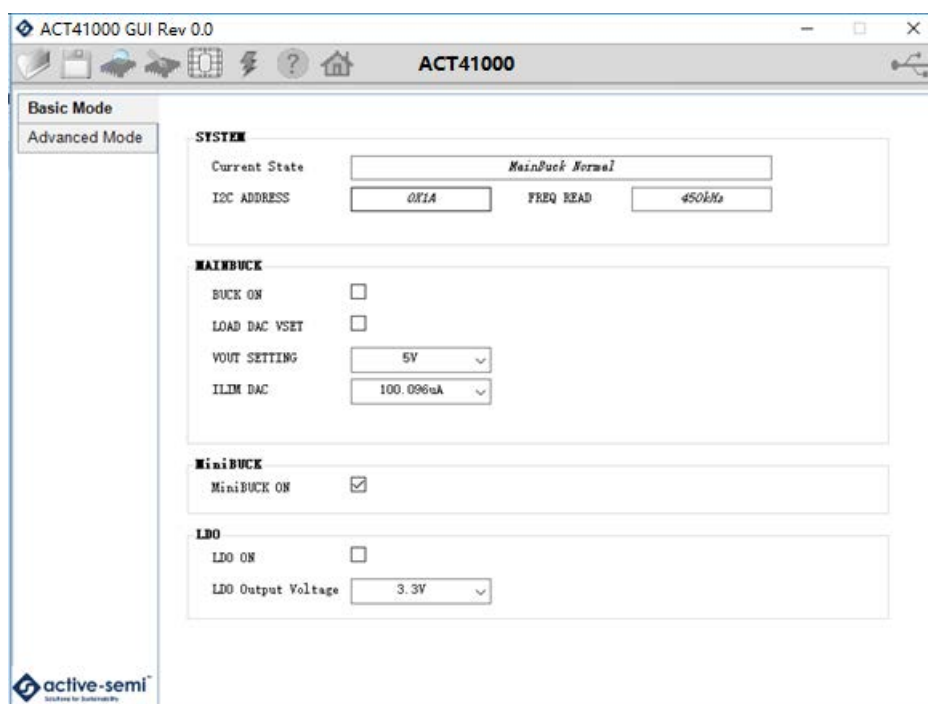

Advanced Mode

Click the “Advanced Mode” button in the left of the GUI screen to see all available user programmable options. With Advanced Mode, additional user programmable features can be selected using the button text. In the left side of the Advanced Mode Screen, click on the Tiles Selector to display the register to view or change. Then change a register one bit at a time by clicking on the desired bit. The value of the bit is display right next to the bit-name button.

Note that the far right side of the screen contains a scroll down button to scroll down to additional registers since the Tile Screen can only display up to 8 bytes at once.

ACT41000 GUI Rev 0.0

ACT41000

Basic Mode
Advanced Mode
REGISTERS

Address 0x00		Address 0x01		Address 0x02		Address 0x03	
RFU	0	BUCK_CVCC_CHG	0	BUCK_CC_FLT	0	SYNC_CLK_HIGH	0
RFU	0	RFU	0	BUCK_OC	0	SYNC_CLK_LOW	0
RFU	0	SYNC_CLK_FLT	0	BUCK_OVP	0	mBUCK_MODE100	0
Current_State[4]	0	FREQ_PIN_FLT	0	BUCK_UVP	0	BUCK_IM_CC	0
Current_State[3]	1	TSD_HARD	0	LDO_UVP	0	BUCK_MODE100	0
Current_State[2]	0	TSD_SOFT	0	V5V_OC	0	BUCK_PG	0
Current_State[1]	1	RFU	0	V5V_OVP	0	LDO_PG	0
Current_State[0]	0	PVIN_OV	0	V5V_UVP	0	V5V_PG	0

Address 0x04		Address 0x05		Address 0x06		Address 0x07	
RFU	0	RFU	0	IRQ_BK_CVCC_MSK	0	IRQ_BK_CC_MSK	0
RFU	0	RFU	0	RFU	0	IRQ_BK_OC_MSK	0
RFU	0	RFU	0	IRQ_Sync_Clk_Msk	0	IRQ_BK_OVP_MSK	0
RFU	0	RFU	0	IRQ_Freq_Pin_Msk	0	IRQ_BK_UVP_MSK	0
RFU	0	RFU	0	IRQ_Tsd_Hard_Msk	0	IRQ_Ldo_Uvp_Msk	0
RFU	0	RFU	0	IRQ_Tsd_Soft_Msk	0	IRQ_V5V_OC_MSK	0
RFU	0	LOAD_DAC_VSET	0	RFU	0	IRQ_V5V_OVP_MSK	0
RFU	0	BUCK_ON	0	IRQ_PVIN_OV_MSK	0	IRQ_V5V_UV_MSK	0

active-semi
Enabling the Future™

Button Descriptions

Read: Clicking on this button reads the ACT41000 registers and displays them in the GUI. Note that this reads all registers. Qorvo recommends reading registers each time the ACT41000 powers-up to acquire the initial register settings. Qorvo also recommends reading registers after making changes to them. Immediately reading the registers after a write confirms the changes were properly stored.



Read Button

Write: Clicking on this button writes the GUI settings to the ACT41000's registers. All registers are written, regardless of whether or not they were changed.

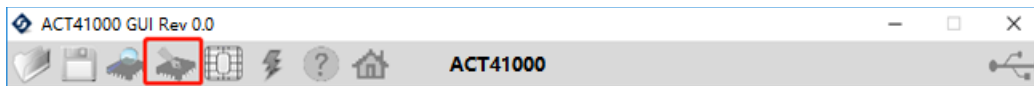

Write Button

Dongle Connection Status: The GUI also contains a dongle connection status that indicates Qorvo's USB-TO-I2C dongle is connected to the USB port. The figure below shows the two possible indication status graphics.

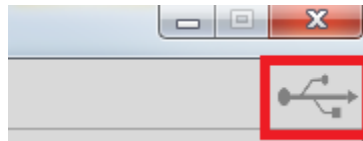

Dongle connected



Dongle Disconnected