



ACT41000

Programmable Voltage, Programmable Current, Low Noise Voltage Regulator for RF Components

Product Overview

The Qorvo[®] ACT41000 is a low noise, dc-to-dc buck converter with a programmable output and auxiliary bias supply regulators. This synchronous step-down voltage regulator supports a wide input voltage of 4.5 V to 40 V and integrates both the high side and low side MOSFETS of 50mΩ R_{DS(ON)} for high efficiency power conversions.

To power up a drain of GaN/GaAs Power Amplifiers (PAs), the ACT41000 supports a programmable output both in voltage and current (limit) setpoints and the device operates in constant-current (CC) and constant-voltage (CV) seamlessly. Qorvo factory-programs the **default settings** and an *optional* MCU can re-program them on-the-fly via I²C. The precise 256-step current limit enables an MCU to **detect precise I_{DQ}** by **eliminating a current sensor IC**.

The Qorvo[®] proprietary current-mode control uses its on-chip oscillator clock with **spread-spectrum** or an **external clock to synchronize**. This fixed frequency operation with the stable control loop greatly reduces output power noise and EMI to noise sensitive RF components.

The ACT41000 provides two (2) auxiliary rails for peripheral devices like controllers, sensors and so on.

The ACT41000 is available in a 32-pin, 5 mm x 5 mm, thermally enhanced QFN package.

Applications

- RF PA (GaN/GaAs) Drain Bias / Power with I_{DQ} Search
- General Telecom and Industrial Power Supplies
- Telecom RF Modules
- Radar Systems

Simplified Application Diagram

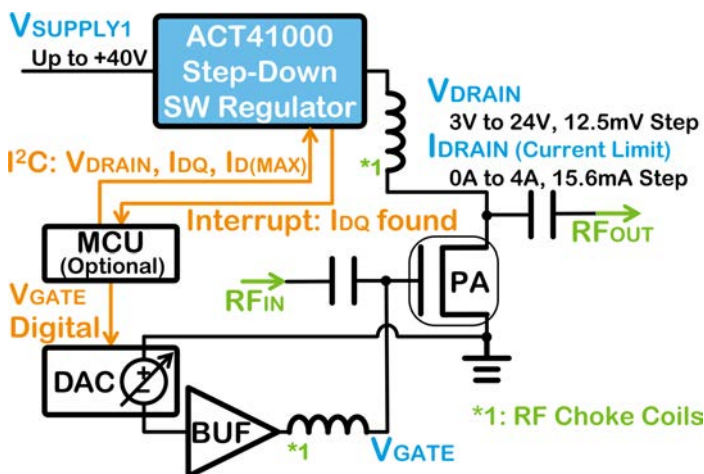

Figure 1. ACT41000 Typical Application Diagram

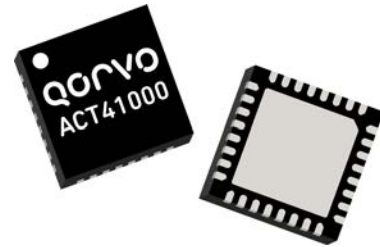

Figure 2. Top View 32-pin 5 x 5 mm QFN Package

Key Features

- 4.5 V to 40 V Operational Input Voltage
- Programmable Output with Factory Defaults
Output Voltage: **3 V to 24 V in 12.5 mV Step**
Output Current (Limit): **Up to 4 A in 15.6 mA Step**
- 450 kHz to 2.25 MHz Fixed-Frequency Current-Mode, with **External Clock Sync.** and **Spread-Spectrum**
- 5 V / 350 mA Self-Bias Buck Converter with
- 20 mA AUX LDO, Programmable Output Voltage
- I²C Interface, Fast-mode Plus (Fm+, 1 MHz)
- Protections:
UVLO, OVP, UVP (Hiccup/Latch-off), OCP, TSD
- Thermally Enhanced 5 mm x 5 mm QFN Package
- **Automotive AEC-Q100 Options Available**
(Contact [Qorvo](#) for conditions of AEC-Q100 options.)

Quad-Phase 360 W ACT41000 Demo

- Total 4 ACT41000 ICs, Two Dual-phase Boards Stacked
- Efficiency $\eta = 97.3\%$
- **V_{NOISE} = 4.95 mV_{RMS}(10 Hz – 100 kHz)**
Input: 27.4 V / 13.5 A, Output: 23.9 V x 15.1 A = **360.0 W**



Figure 3. Four-Phase ACT41000 Reference Board

Ordering Information

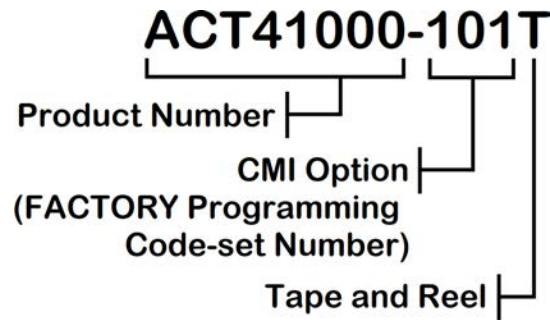

Figure 4. Part Numbering Structure

- Standard product options are identified in this table. Contact local sales for custom options, minimum order quantity required.
- This device is RoHS Compliant and with Pb-free plating unless specified differently. The term Pb-free means semiconductor products that are in compliance with current RoHS (Restriction of Hazardous Substances) standards.
- See the [Factory Programming Options](#) section for more information about CMI.

PART NUMBER	AEC-Q100	User Programmable Parameter Default			Target Qorvo® RF PA
		(Drain) Output Voltage ^[1]	Precise Output Current Limit ^[2]	AUX LDO Voltage ^[3]	
ACT41000-101	—	5.0 V	4.0 A	3.3 V	(Generic Use)
ACT41000-102	—	24.0 V	4.0 A	3.3 V	SPATIUM® Products
ACT41000-103	—	6.0 V	2.0 A	3.3 V	TGA4544-SM
ACT41000-104	—	22.0 V	3.5 A	3.3 V	QPA2211
ACT41000-105	—	24.0 V	1.9 A	3.3 V	(Generic Use)

Not all options are released, please contact your local sales representatives or customer.support@qorvo.com for a status and availability. Also, see [Factory Programming Options](#).

Similar Devices

Following devices are similar to the ACT41000 device.

PART NUMBER	AEC-Q100	User Programmable Parameter Default			Target Qorvo® RF PA
		(Drain) Output Voltage ^[1]	Precise Output Current Limit ^[2]	AUX LDO Voltage ^[3]	
ACT41001-101	YES	5.0 V	4.0 A	3.3 V	(Generic Use)

Not all options are released, please contact your local sales representatives or customer.support@qorvo.com for a status and availability. Also, see [Factory Programming Options](#).

^[1] Upon requests, output voltage options are available from 3.0 V to 24.0 V in 12.5mV steps, where a minimum required quantity applies.

^[2] Upon requests, precise output current limit options are available from 1 A to 4 A in 15.6 mA steps, where a minimum required quantity applies.

^[3] Upon requests, AUX LDO voltage options are available from 0.9 V to 4.05 V in 50 mV steps, where a minimum required quantity applies.

Specifications

Pin Configuration

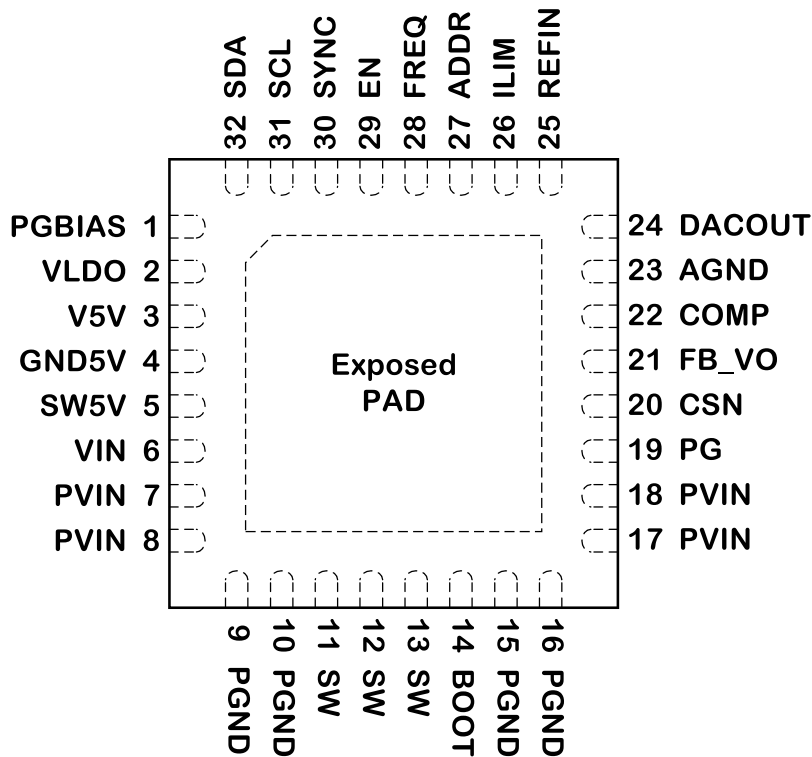

Figure 5. 32-pin QFN, 5 mm x5 mm, 0.5 mm pitch, TOP VIEW

Pin Functions

PIN	NAME	DESCRIPTION
1	PGBIAS	Power-good output of the Mini-buck Regulator and Auxiliary LDO . Open-drain and a pull-up resistor required. See PGBIAS Indicator Output .
2	VLDO	Output voltage node of the Auxiliary LDO . Connect a good quality, fixed value 1 μ F capacitor between this pin and the GND5V pin. See Auxiliary LDO .
3	V5V	5 V bias supply to the device and voltage feedback of the Mini-buck Regulator . Connect two good quality capacitors in parallel, two 10 μ F and one 0.1 μ F between this pin and the GND5V pin. Place the 0.1 μ F capacitor with the minimum distance to the device.
4	GND5V	Ground node for the Mini-buck Regulator .
5	SW5V	Switching node of the Mini-buck Regulator .
6	VIN	Power supply to the device. Connect a good quality 1 μ F capacitor, at least, between this pin and the GND5V pin. On a PCB, tied to the PVIN pin.
7,8,17,18	PVIN	Power supply to the Main-buck Regulator . Connect good quality two 22 μ F capacitors, at least, between this pin and the PGND pins, also tie to the VIN pin.
9,10,15,16	PGND	Ground node for the Main-buck Regulator .
11,12,13	SW	Switching node of the Main-buck Regulator .
14	BOOT	Bootstrap capacitor node for the Main-buck Regulator . Connect a good quality, fixed value 0.1 μ F capacitor between this pin and the SW pin.
19	PG	Power-good output of the Main-buck Regulator . Open-drain and a pull-up resistor required.
20	CSN	Current sense feedback input to the Main-buck Regulator . See Output Current Sensing .
21	FB_VO	Voltage feedback input to the Main-buck Regulator . See Reference Voltage Input .
22	COMP	Error amplifier output. Connect a compensation network between this pin and the AGND pin. See Main-buck Compensation Network .
23	AGND	Ground node for analog blocks of the device.
24	DACOUT	Reference voltage output from the DAC. Usually, short to the REFIN pin. See Output Voltage Reference .
25	REFIN	Reference voltage input to the Main-buck Regulator . See Reference Voltage Input .
26	ILIM	Output current limit programming of the Main-buck Regulator . Connect a resistor between this pin and the AGND pin. See Output Current Reference .
27	ADDR	I^2C address selection. Connect a resistor between this pin and the ground. See I²C Address Selection .
28	FREQ	Switching frequency programming of the Main-buck Regulator . Connect a resistor between this pin and the AGND pin. See Clock Generator .
29	EN	Enable logic input for the Main-buck Regulator . See Main-buck Enable Control .
30	SYNC	Clock synchronizing input/output for the Main-buck Regulator . See Clock Synchronizer .
31	SCL	Clock port of the I²C Interface . Open-drain and a pull-up resistor required.
32	SDA	Data port of the I²C Interface . Open-drain and a pull-up resistor required.
Exposed PAD		Substrate contact for power dissipation. Connect to the PGND pins with a broad pattern.

Absolute Maximum Ratings

PARAMETER	VALUE	UNIT
PVIN, VIN	-0.3 to +48.0	V
SW	-0.3 to (PVIN + 1.0)	V
FB_VO, CSN	-0.3 to +28.0	V
Voltage difference between FB_VO and CSN	-0.3 to +0.3	V
SW5V	-0.3 to (VIN + 1.0)	V
BOOT	(V _{SW} - 0.3) to (V _{SW} + 6.0)	V
PGND, GND5V, w.r.t. AGND	-0.3 to +0.3	V
EN, PG, PGBIAS, SYNC, REFIN, SDA, SCL, COMP, V5V (external supply)	-0.3 to +6.0	V
Operation Junction Temperature (T _J)	-40 to +150	°C
Storage Temperature	-55 to +150	°C
Lead Temperature (Soldering 10sec)	up to +300	°C

Do not exceed these limits to prevent damage to the device. Exposure to absolute maximum rating conditions for long periods may affect device reliability.

All voltage values are with respect to the ground voltage unless otherwise specified.

Recommended Operating Conditions

PARAMETER	VALUE	UNIT
PVIN, VIN	+4.2 to +40.0	V
V5V (External Supply)	+4.5 to +5.5	V
EN, PG, PGBIAS, SYNC, REFIN, SDA, SCL, COMP	-0.3 to +5.5	V
Operation Junction Temperature (T _J)	-40 to +125	°C
Current Sensing Resistor (R _{CS})	5 to 80	mΩ
Frequency Programming Resistor (R _{FREQ})	40 to 200	kΩ

All voltage values are with respect to the ground voltage unless otherwise specified.

Package Thermal Information

PARAMETER	VALUE	UNIT
Thermal Resistance, Junction to Ambient (Θ _{JA}) ^[1]	24	°C/W

^[1] Reference number, based on a real measurement of a ACT41000 evaluation board.

Electrical Characteristics

PVIN = VIN = 12 V, V5V = 5 V (external supply), EN = 5 V, T_A = 25°C, unless otherwise specified

PARAMETER	SYMBOL	TEST CONDITION	MIN	TYP	MAX	UNIT
BIAS BLOCK						
VIN Mini-buck Consumption Current	I _{I(VIN)}	EN = 0 V, V5V = 5.25 V, mini-buck ON and no switching		235		μA
V5V Quiescent Current	I _{Q(V5V)}	EN = 0 V, V5V = 5.25 V, mini-buck ON and no switching		1.3		mA
V5V Non-switching Current	I _{I(V5V)}	EN = 5 V, V5V = 5.25 V, main-buck ON and no switching		2.8		mA
VIN Under-voltage Lock-out Threshold	V _{IT(UVLO)}	VIN rising to release	4.25		4.5	V
	V _{IT(UVLO,fall)}	VIN falling to lock			4.1	
VIN Over-voltage Lock-out Threshold	V _{IT(OVLO)}	VIN rising to lock		42		V
	V _{IT(OVLO,fall)}	VIN falling to unlock		39		
V5V Regulation	V _{O(V5V)}	V5V error comparator threshold	4.8	5.0	5.2	V
V5V PG Threshold	V _{IT(V5V)}	V5V rising	4.25			V
V5V Under-voltage	V _{UVP(V5V)}	V5V falling	3.95		4.15	V
V5V Over-voltage	V _{OPP(V5V)}	V5V rising		5.9		V
VLDO Regulation	V _{O(VLDO)}	I _{VLDO} = 10mA Reg0D[5:0] = 0x30	3.14	3.3	3.47	V
VLDO Under-voltage	V _{UVP(VLDO)}	Reg0D[5:0] = 0x30	2.9			V
PGBIAS Output Voltage	V _{OL(PGBIAS)}	PGBIAS at logic-L, 1 mA Current into PGBIAS pin			0.3	V
Mini-buck Over-current	I _{OCP(V5V)}		360			mA
VLDO Over-current	I _{OCP(VLDO)}		20			mA
Thermal Protection	T _{SD(HARD)}	Hard TSD, temperature rising		155		°C
	T _{SD(SOFT)}	Soft TSD, temperature rising		145		
	T _{SD(OFF)}	TSD release, temperature falling		135		
SIGNAL PINS						
Signal Pin Input Current	I _{I(FB_VO)}	5 V target (DACOUT[10:0] = 0x190)		6		μA
	I _{I(CSN)}			6		μA
	I _{I(SYNC)}				1	μA
Signal Pin Output Current	I _{O(ADDR)}	R _{ADDR} = 50 kΩ while PGBIAS=L		20		μA
Signal Pin Output Voltage	V _{O(FREQ)}	R _{FREQ} = 40 kΩ		1.2		V
EN Threshold	V _{IT(EN)}		1.15		1.25	V
EN Pin Pull-up Current	I _{O(EN,rise)}	V _{EN} < V _{IT(EN)}		1		μA
	I _{O(EN,fall)}	V _{EN} > V _{IT(EN)}		2		

PARAMETER	SYMBOL	TEST CONDITION	MIN	TYP	MAX	UNIT
SYNC Pin Input Threshold	$V_{IT(SYNC)}$	SYNC pin in slave	0.55		1.4	V
SYNC Pin Output Voltage	$V_{OH(SYNC)}$	SYNC pin in master, outputs logic-H	3.2		V5V	V
	$V_{OL(SYNC)}$	SYNC pin in master, outputs logic-L	0		0.8	
I²C PINS						
Input Threshold	$V_{IT(I^2C)}$	SDA and SCL pins	0.55		1.25	V
Leakage Current	$I_{LK(SDA)}$	$V_{SDA} = 5\text{ V}$			1	μA
Output Voltage	$V_{OL(SDA)}$	5 mA Current into SDA pin			0.35	V
Input Capacitance	$C_{I(I^2C)}$	SDA and SCL pins			10	pF
MAIN-BUCK REGULATOR						
DACOUT Accuracy	$V_{DACOUT(24)}$	24 V target ($DACOUT[10:0] = 0x780$), 50 μA current DACOUT sourcing	-0.5%	3.0	+0.5%	V
	$V_{DACOUT(5)}$	5 V target ($DACOUT[10:0] = 0x190$), 50 μA current DACOUT sourcing	-0.5%	0.625	+0.5%	
	ΔV_{DACOUT}	$V_{DACOUT(n+1)} - V_{DACOUT(n)}$	0	1.5625		mV
FB_VO Accuracy	V_O	W.r.t. V_{REFIN} , $V_{REFIN} = 3\text{ V}$	-1%	24	1%	V
Output Current Limit Programming Accuracy	$I_{LIM(100)}$	100% target ($ILIM[7:0] = 0xFF$)	98.5		101.5	μA
	$I_{LIM(25)}$	25% target ($ILIM[7:0] = 0x3F$)	24.25		25.75	
	ΔI_{LIM}	$I_{LIM(n+1)} - I_{LIM(n)}$	0	0.4		
Constant Current Operation Programming Accuracy	$V_{CCMODE(100)}$	Differential voltage ($V_{FB_VO} - V_{CSN}$) at $V_{LIM} = 1.6\text{ V}$	78.5		81.5	mV
	$V_{CCMODE(25)}$	Differential voltage ($V_{FB_VO} - V_{CSN}$) at $V_{LIM} = 0.4\text{ V}$	19.3		20.7	
PG Output Voltage	$V_{OL(PG)}$	PG at logic-L, 1 mA Current into PG pin			0.3	V
PG Threshold Upper Limit ^[1]	$V_{IH(VO)}$	Threshold of Reg03[2] , VO_FB w.r.t. V_{REFIN} , $V_{REFIN} = 3\text{ V}$	+5%		+8%	
PG Threshold Lower Limit ^[1]	$V_{IL(VO)}$	Threshold of Reg03[2] , VO_FB w.r.t. V_{REFIN} , $V_{REFIN} = 3\text{ V}$	-8%		-5%	
FB_VO Over-voltage	V_{OVP}	VO_FB w.r.t. V_{REFIN} , $V_{REFIN} = 3\text{ V}$	+8%			V
FB_VO Under-voltage ^[2]	$V_{UVP(CC)}$	Reg0B[3] = logic-L, VO_FB w.r.t. V_{REFIN} , $V_{REFIN} = 3\text{ V}$		2.7	2.76	V
	$V_{UVP(CV)}$	Reg0B[3] = logic-H, VO_FB w.r.t. V_{REFIN} , $V_{REFIN} = 3\text{ V}$			-8%	
FB_VO Constant Current Activation Threshold	$V_{IT(CC,rise)}$	Enable CC loop, Reg09[3] = logic-H, VO_FB rising		2.3	2.5	V
	$V_{IT(CC,fall)}$	Disable CC loop, Reg09[3] = logic-H, VO_FB falling		2.2		
Main-buck Cycle-by-cycle Current Limit	$I_{OCP(CBC,high)}$	High-side FET limit to trigger	5.5			A
	$I_{OCP(CBC,low)}$	Low-side FET limit to release		4.2		

PARAMETER	SYMBOL	TEST CONDITION	MIN	TYP	MAX	UNIT
Discharge Resistance	R_{DIS}			1.2		k Ω

^[1] See [Main-buck Power-Good](#) for details.

^[2] See [Under-Voltage Protection](#) for details.

Timing Requirements

PARAMETER	SYMBOL	CONDITION	MIN	TYP	MAX	UNIT
I²C BLOCK						
SCL Clock Frequency	f_{SCL}	(no internal time out)	0		1000	kHz
SCL Pulse Width	$t_{LOW(SCL)}$	Logic-L level	0.5			μ s
	$t_{HIGH(SCL)}$	Logic-H level	0.26			
SDA Set-up Time	$t_{SU(SDA)}$		50			ns
SDA Hold Time	$t_{H(SDA)}$		0			ns
START Set-up Time	$t_{SU(START)}$		260			ns
STOP Set-up Time	$t_{SU(STOP)}$		260			ns
EN pin INPUT						
EN Pulse Width	$t_{LOW(EN)}$	Logic-L level	30			μ s
SYNC pin INPUT						
SYNC Frequency Range	f_{SYNC}	$20k\Omega < R_{ADDR} < 50k\Omega$	400		2500	kHz
SYNC Frequency Accuracy		$20k\Omega < R_{ADDR} < 50k\Omega$, referring to the frequency setpoint by R_{FREQ}	75%		125%	
SYNC Input Duty	$D_{IN(SYNC)}$	$20k\Omega < R_{ADDR} < 50k\Omega$	40%		60%	

Switching Characteristics

$PV_{IN} = V_{IN} = 12 V$, $V5V = 5 V$ (external supply), $EN = 5 V$, $T_A = 25^\circ C$, unless otherwise specified

PARAMETER	SYMBOL	TEST CONDITION	MIN	TYP	MAX	UNIT
BIAS BLOCK						
Mini-Buck Switching Frequency	$f_{SW(V5V)}$		2.0			MHz
Mini-Buck Spread-Spectrum Dithering Range ^[1]	$f_{SPSP(V5V)}$	Frequency modulation range w.r.t. $f_{SW(V5V)}$ value		$\pm 7\%$		
Mini-Buck Spread-Spectrum Cycle	$N_{SPSP(V5V)}$	Number of T_{ON} cycles		32		cycle
Mini-Buck Soft-Start Time	$t_{SS(V5V)}$	" $V_{IN} = V_{IT(UVLO)}$ " to " $V5V = V_{IT(V5V)}$ "		0.5		ms
Mini-Buck UVP Mask Timer	$t_{D(V5V,mask)}$			1		ms
Wait Timer before Error Reset	$t_{D(RESET)}$			100		ms
PGBIAS Delay	$t_{D(PGBIAS)}$	" $V5V = V_{IT(V5V)}$ " to $PGBIAS \uparrow$, target 3 ms ($Reg08[4:3] = 11$)	-10%	3	10%	ms

PARAMETER	SYMBOL	TEST CONDITION	MIN	TYP	MAX	UNIT
AUX LDO Soft-Start Time ^[2]	$t_{SS(LDO)}$	Just for reference, <code>Reg0D[5:0] = 0x31</code>		100		μs
I²C BLOCK						
SDA Fall Time	$t_{F(SDA)}$	Pull-up to 5-V source via 10 k Ω			120	ns
MAIN-BUCK REGULATOR						
Main-Buck Switching Frequency	$f_{SW(MAIN)(min)}$	$R_{FREQ} = 200\text{ k}\Omega$	400	450	500	kHz
	$f_{SW(MAIN)(max)}$	$R_{FREQ} = 40\text{ k}\Omega$	2.0	2.25	2.5	MHz
SYNC Output Duty Cycle	$D_{OUT(SYNC)}$			50%		
SYNC Input WDT Error Detection	$\Delta f_{SYNC(low)}$	$20\text{ k}\Omega < R_{ADDR} < 50\text{ k}\Omega$, referring to the frequency setpoint by R_{FREQ}			40%	
	$\Delta f_{SYNC(high)}$		210%			
Main-Buck Spread-Spectrum Dithering Range ^[1]	$f_{SPSP(MAIN)}$	Frequency modulation range w.r.t. $f_{SW(MAIN)}$		$\pm 7\%$		
Main-Buck Spread-Spectrum Cycle	$N_{SPSP(MAIN)}$	Number of T_{ON} cycles		64		cycle
ON Time Control	$t_{ON(min)}$			65	80	ns
OFF Time Control	$t_{OFF(min)}$			65	80	ns
Main-Buck Digital Servo Clock Period	$t_{W(SERVO)}$			8		μs
Hiccup Timer	$t_{W(HICCUP)}$			100		ms
PG Delay	$t_{D(PG)(min)}$	$FB_VO > V_{IL(VO)}$, 0 ms target (<code>Reg08[7:6] = 00</code>)			10	μs
	$t_{D(PG)(max)}$	$FB_VO > V_{IL(VO)}$, 4 ms target (<code>Reg08[7:6] = 11</code>)	-10%	4	10%	ms

^[1] No production test

^[2] Not actively controlled, application board dependent

Typical Characteristic and Application Performance Curves

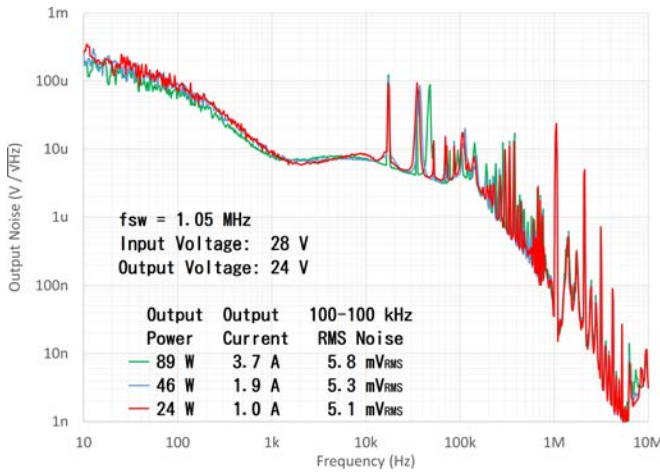

Figure 6. Output Noise Spectral Density by Output Current
 Time-domain waveforms: [Figure 8](#), [Figure 9](#)

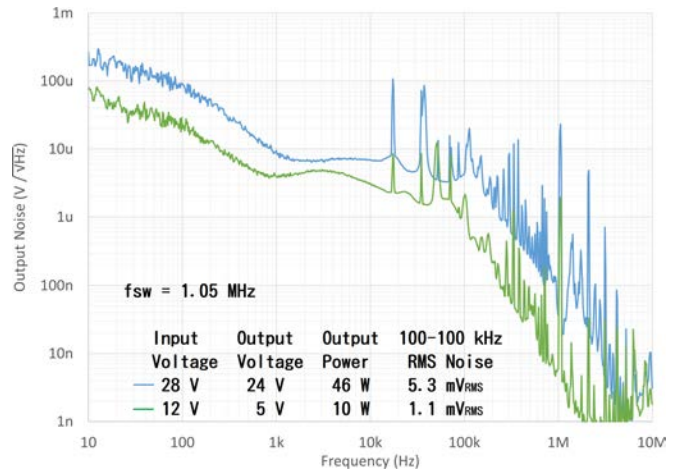

Figure 7. Output Noise Spectral Density by Output Voltage
 Time-domain waveforms: [Figure 10](#), [Figure 9](#), [Figure 11](#)

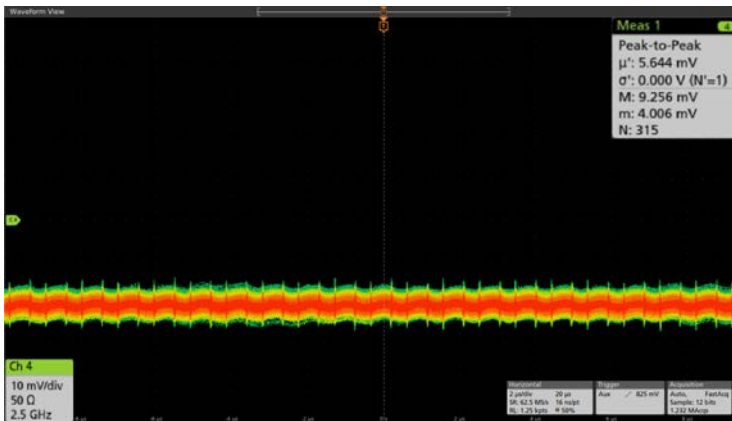

Figure 8. Output Ripple @ 10 W / 5 V
 Frequency-domain waveform: [Figure 7](#)

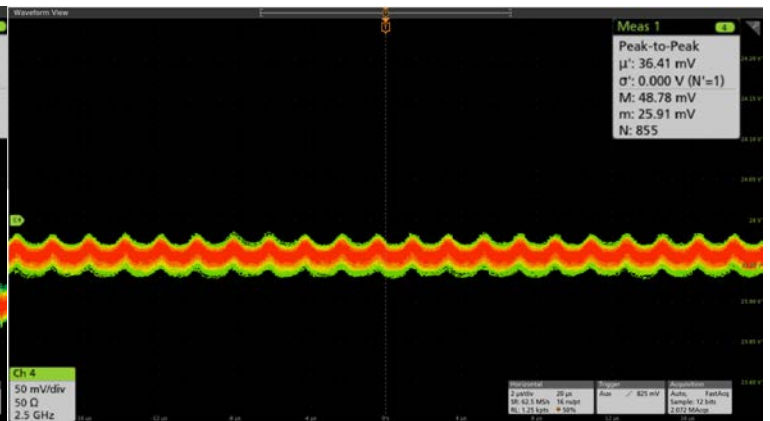

Figure 9. Output Ripple @ 46 W / 24 V
 Frequency-domain waveforms: [Figure 7](#), [Figure 6](#)

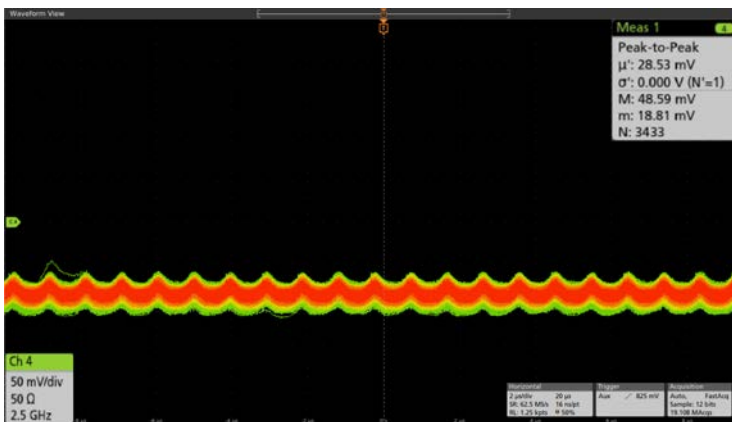

Figure 10. Output Ripple @ 89 W / 24 V
 Frequency-domain waveform: [Figure 6](#)

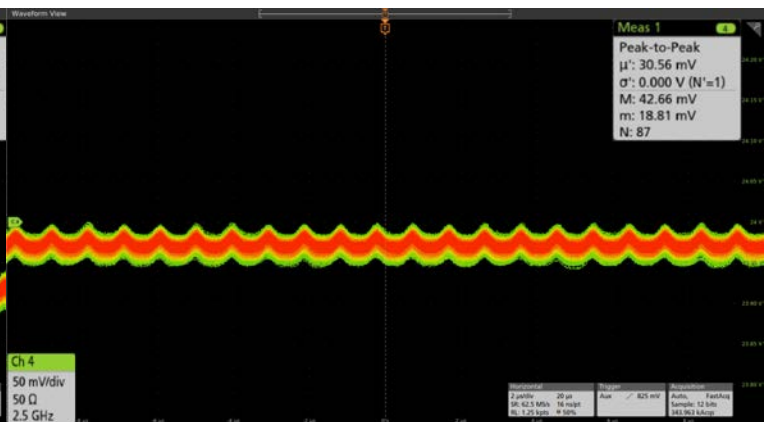

Figure 11. Output Ripple @ 24 W / 24 V
 Frequency-domain waveform: [Figure 6](#)

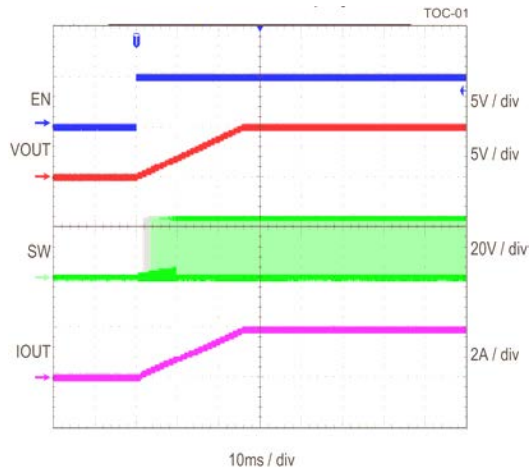

Figure 12. Main-buck Startup by EN

$V_{PVIN} = 24\text{ V}$, $V_{FB_VO} = 5\text{ V}$ (target), $I_{OUT} = 2\text{ A}$

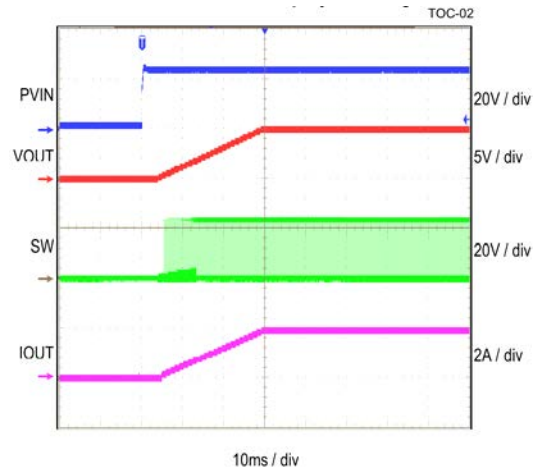

Figure 13. Main-buck Startup by PVIN Hot-plug

$V_{PVIN} = 24\text{ V}$, $V_{FB_VO} = 5\text{ V}$ (target), $I_{OUT} = 2\text{ A}$

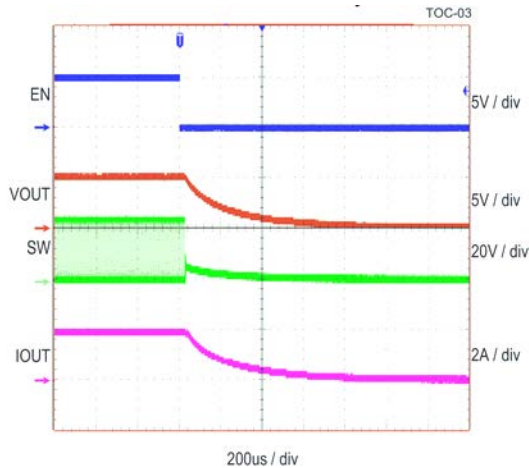

Figure 14. Main-buck Shutdown by EN

$V_{PVIN} = 24\text{ V}$, $V_{FB_VO} = 5\text{ V}$ (target), $I_{OUT} = 2\text{ A}$

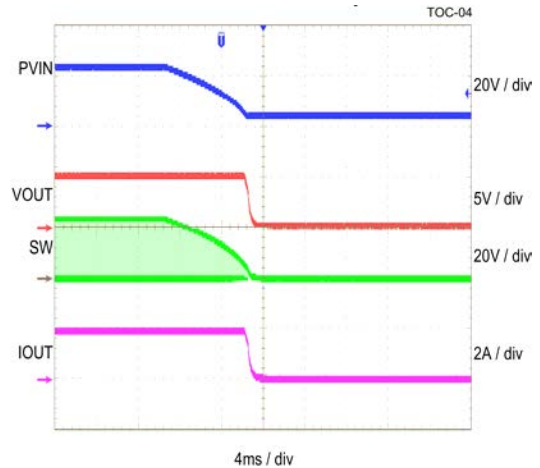

Figure 15. Main-buck Shutdown by PVIN Plug-out

$V_{PVIN} = 24\text{ V}$, $V_{FB_VO} = 5\text{ V}$ (target), $I_{OUT} = 2\text{ A}$

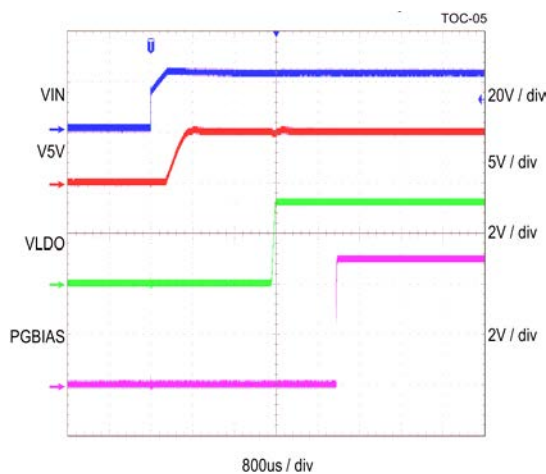

Figure 16. Mini-buck Startup

$V_{IN} = 24\text{ V}$, $I_{OUT} = (\text{no load})$

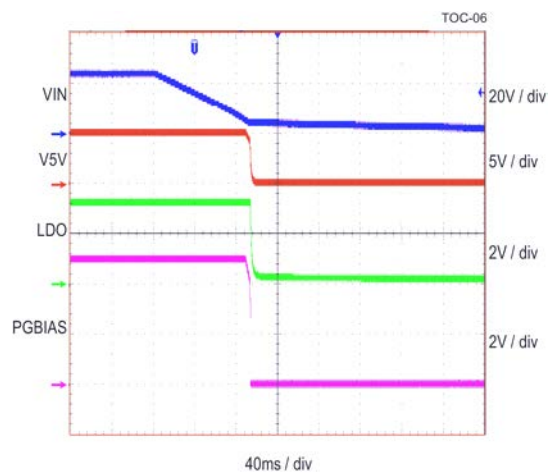

Figure 17. Mini-buck Shutdown

$V_{IN} = 24\text{ V}$, $I_{OUT} = (60\ \Omega\ \text{load})$

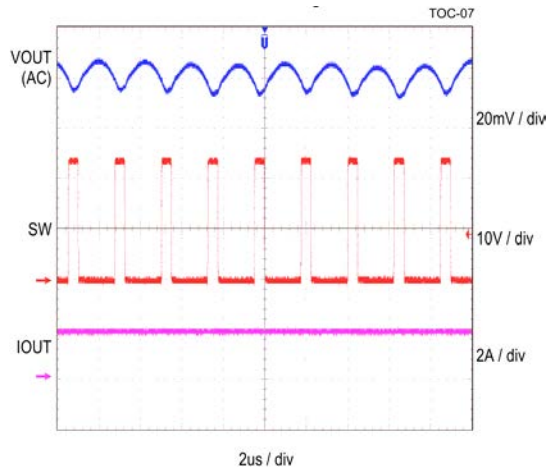

Figure 18. Main-buck Switching Waveform

$V_{PVIN} = 24\text{ V}$, $V_{FB_VO} = 5\text{ V}$ (target), $I_{OUT} = 2\text{ A}$

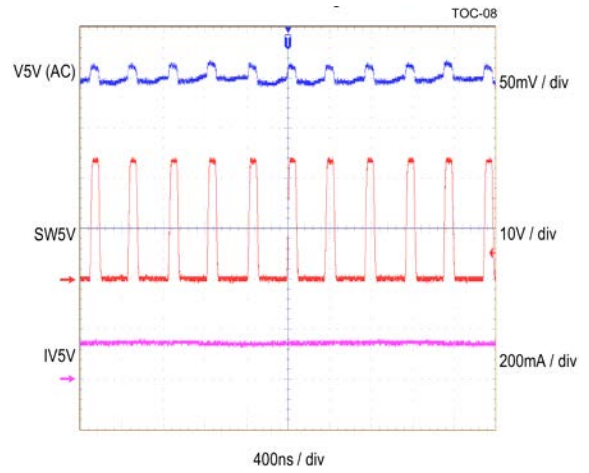

Figure 19. Mini-buck Switching Waveform

$V_{IN} = 24\text{ V}$, $I_{OUT} = 150\text{ mA}$

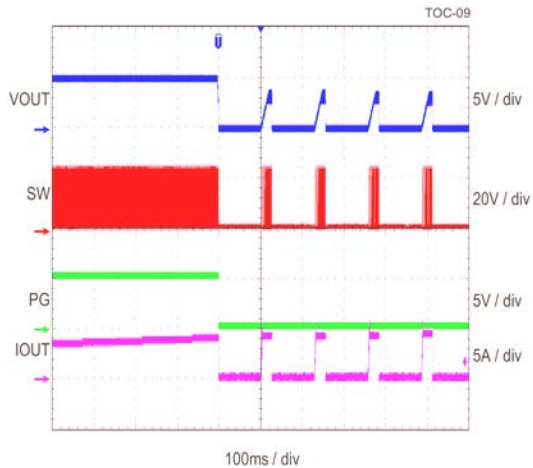

Figure 20. Main-buck Over Current Protection

$V_{PVIN} = 24\text{ V}$, $V_{FB_VO} = 5\text{ V}$ (target)

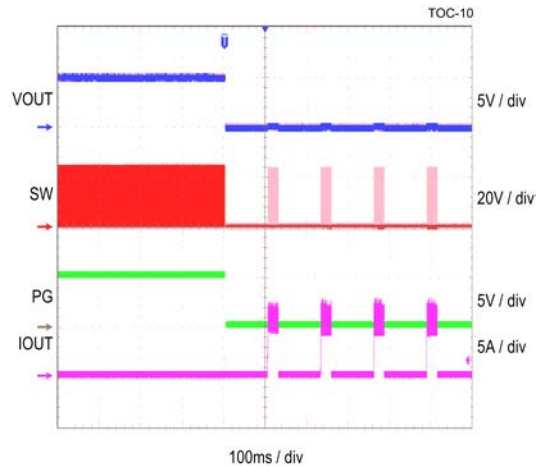

Figure 21. Main-buck Short Circuit Protection

$V_{PVIN} = 24\text{ V}$, $V_{FB_VO} = 5\text{ V}$ (target)

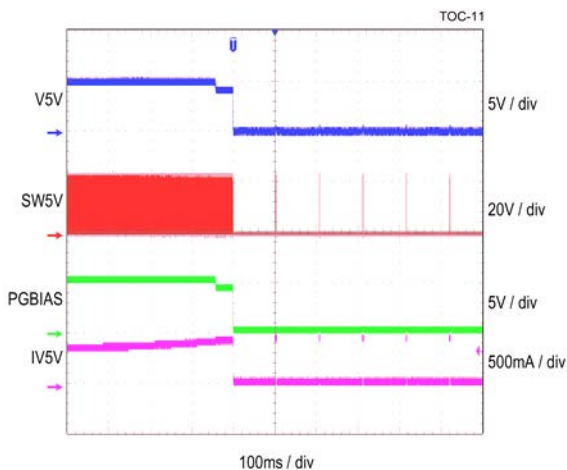

Figure 22. Mini-buck Over Current Protection

$V_{IN} = 24\text{ V}$

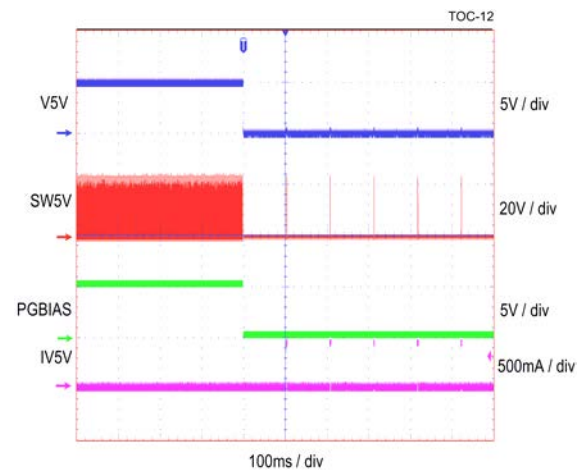

Figure 23. Mini-buck Short Circuit Protection

$V_{IN} = 24\text{ V}$

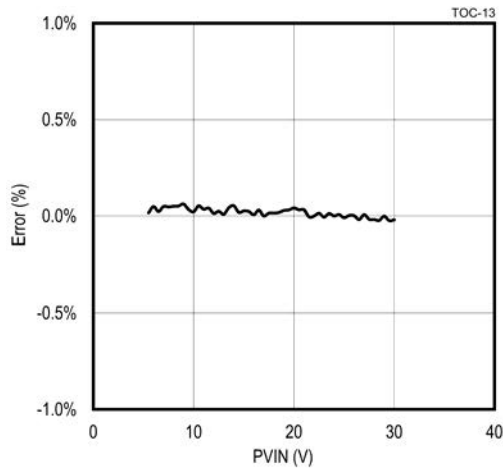

Figure 24. Main-buck Line Regulation

$V_{PVIN} = 4$ to 30 V, $V_{FB_VO} = 5$ V (target), $I_{OUT} = 2$ A

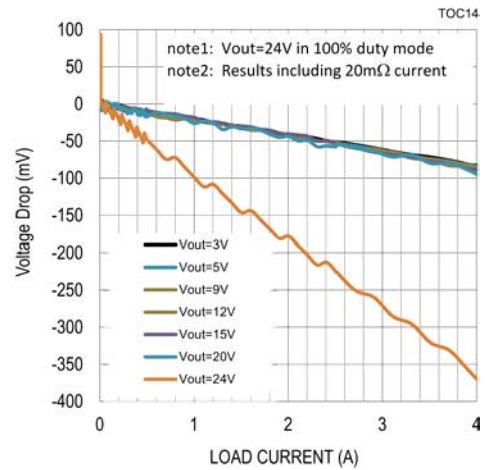

Figure 25. Main-buck Load Regulation

$V_{PVIN} = 24$ V, $V_{FB_VO} = 5$ V (target), $I_{OUT} = 0$ to 4 A

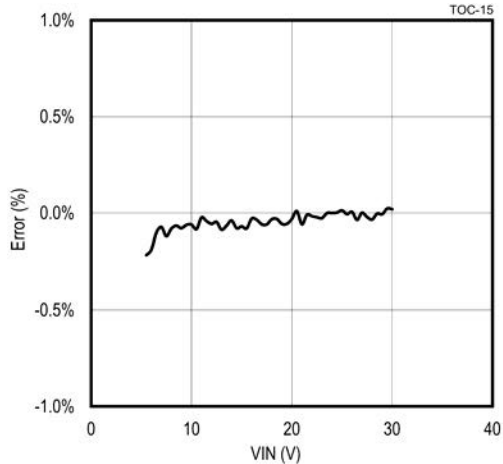

Figure 26. Mini-buck Line Regulation

$V_{IN} = 4$ to 30 V, $I_{OUT} = 150$ mA

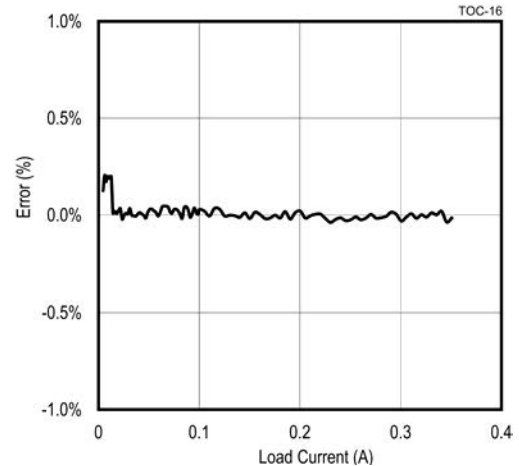

Figure 27. Mini-buck Load Regulation

$V_{IN} = 24$ V, $I_{OUT} = 0$ to 350 mA

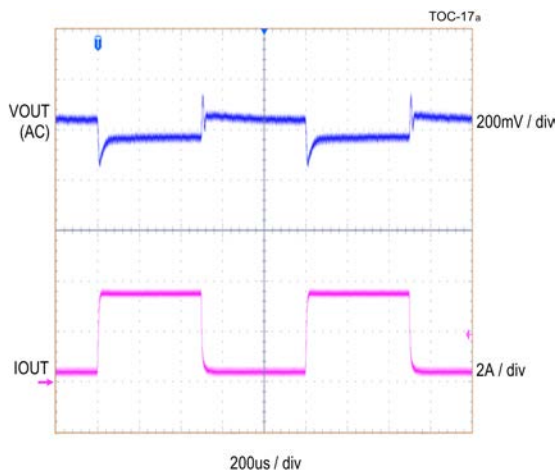

Figure 28. Main-buck Load Transient

$V_{PVIN} = 24$ V, $V_{FB_VO} = 5$ V (target),
 $I_{OUT} = 0.4$ to 3.6 A

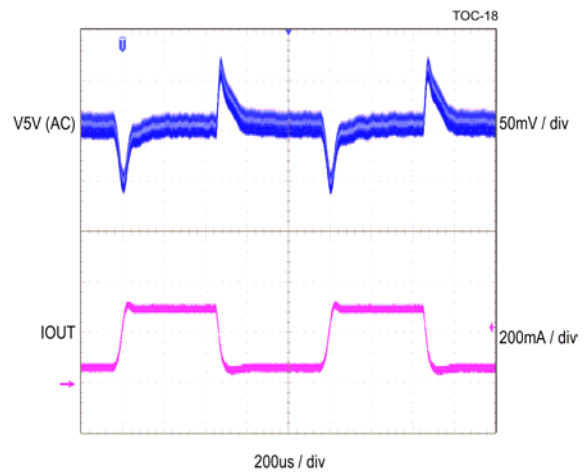

Figure 29. Mini-buck Load Transient

$V_{IN} = 24$ V, $I_{OUT} = 35$ to 300 mA

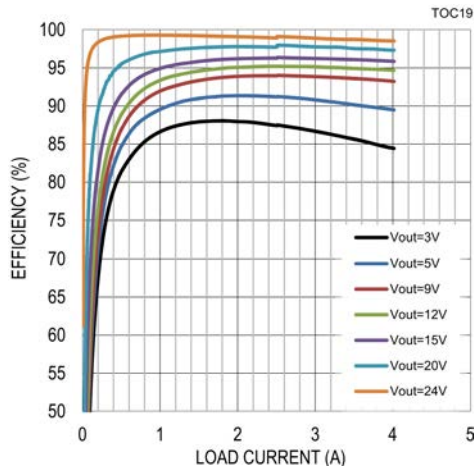

Figure 30. Main-buck Efficiency

$V_{PVIN} = 24\text{ V}$, $V_{FB_VO} = 3,5,9,12,15,20,24\text{ V}$ (target), $I_{OUT} = 0\text{ to }4\text{ A}$

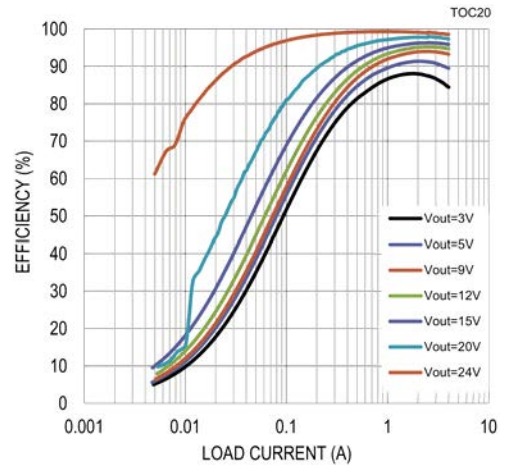

Figure 31. Main-buck Efficiency (Log scale)

$V_{PVIN} = 24\text{ V}$, $V_{FB_VO} = 3,5,9,12,15,20,24\text{ V}$ (target), $I_{OUT} = 0\text{ to }4\text{ A}$

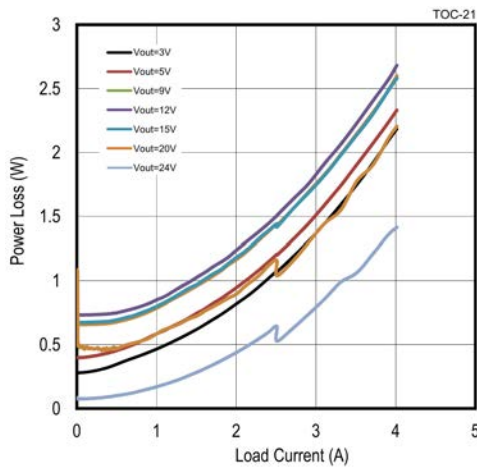

Figure 32. Main-buck Power Loss

$V_{PVIN} = 24\text{ V}$, $V_{FB_VO} = 3,5,9,12,15,20,24\text{ V}$ (target), $I_{OUT} = 0\text{ to }4\text{ A}$

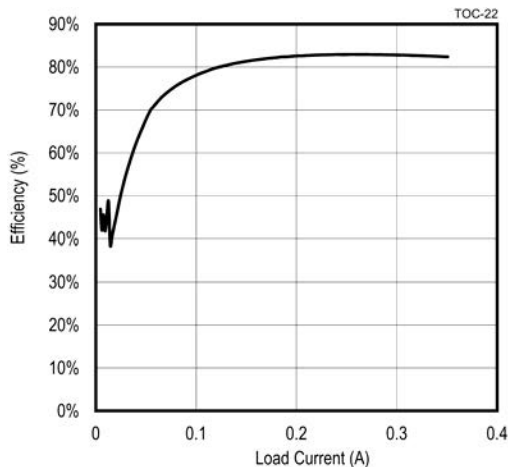

Figure 33. Mini-buck Efficiency

$V_{IN} = 24\text{ V}$, $I_{OUT} = 0\text{ to }350\text{ mA}$

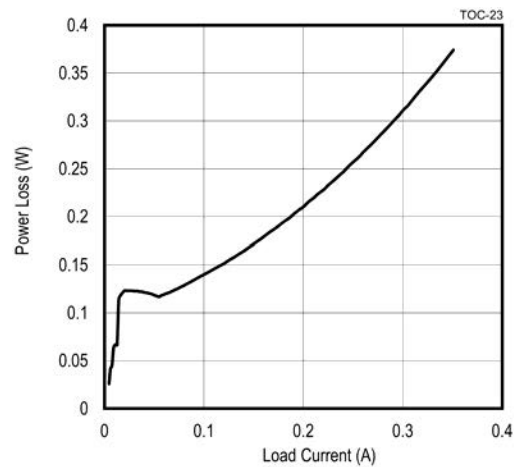

Figure 34. Mini-buck Power Loss

$V_{IN} = 24\text{ V}$, $I_{OUT} = 0\text{ to }350\text{ mA}$

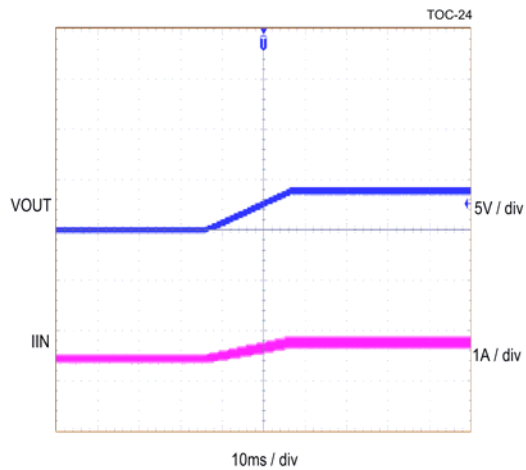

Figure 35. Main-buck Programming 5 to 9 V

$V_{PVIN} = 24\text{ V}$, $I_{OUT} = 2\text{ A}$

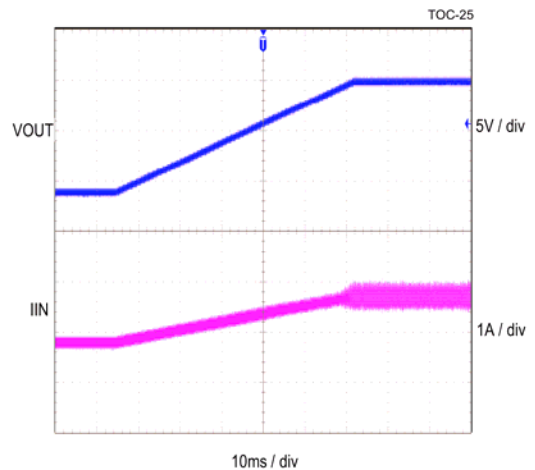

Figure 36. Main-buck Programming 9 to 20 V

$V_{PVIN} = 24\text{ V}$, $I_{OUT} = 2\text{ A}$

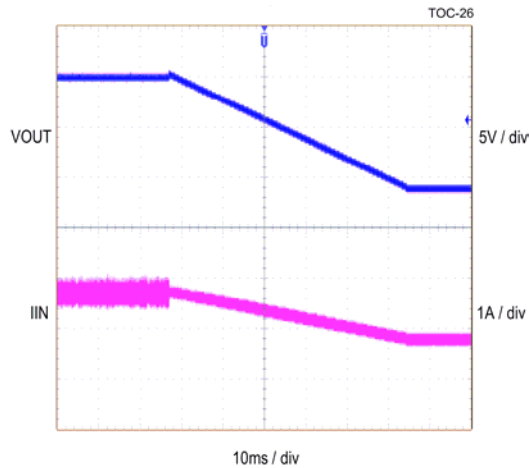

Figure 37. Main-buck Programming 20 to 9 V

$V_{PVIN} = 24\text{ V}$, $I_{OUT} = 2\text{ A}$

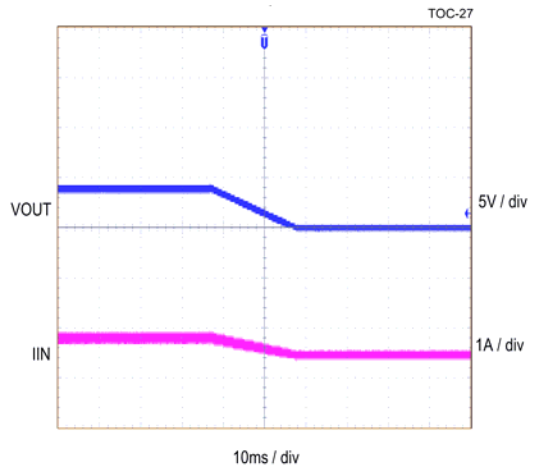

Figure 38. Main-buck Programming 9 to 5 V

$V_{PVIN} = 24\text{ V}$, $I_{OUT} = 2\text{ A}$

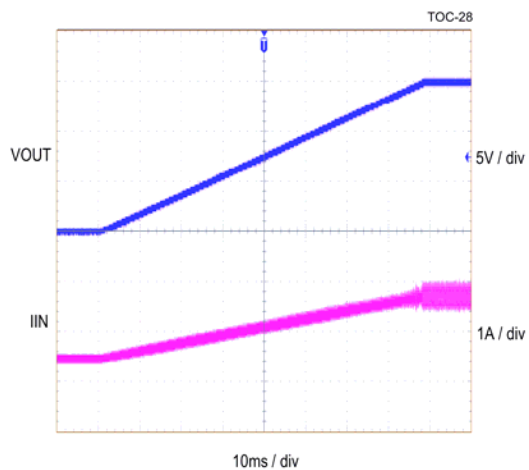

Figure 39. Main-buck Programming 5 to 20 V

$V_{PVIN} = 24\text{ V}$, $I_{OUT} = 2\text{ A}$

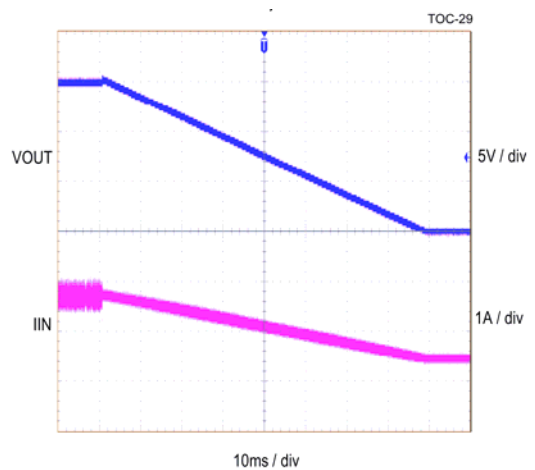

Figure 40. Main-buck Programming 20 to 5 V

$V_{PVIN} = 24\text{ V}$, $I_{OUT} = 2\text{ A}$

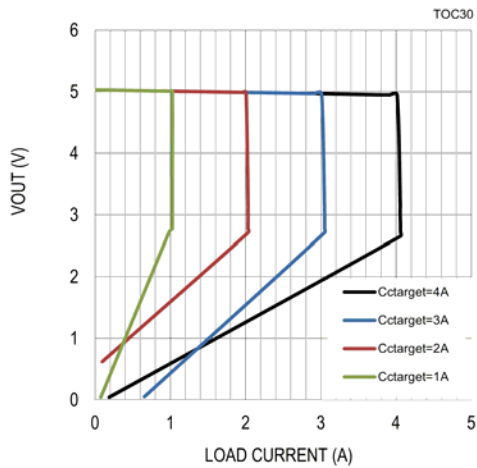

Figure 41. Main-buck Constant Current

$V_{PVIN} = 24\text{ V}$, $V_{FB_VO} = 5\text{ V}$ (target), $I_{OUT} = 1, 2, 3, 4\text{ A}$

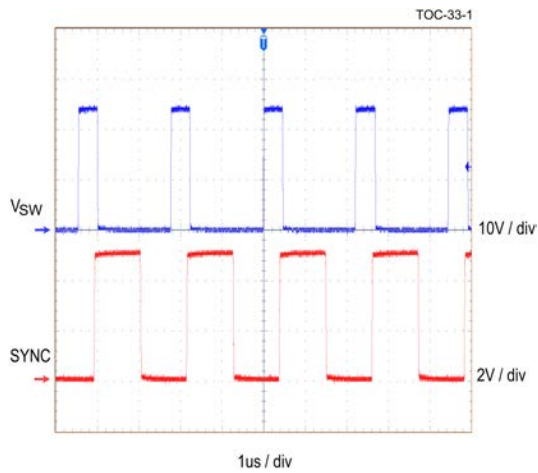

Figure 42. Clock-master: SYNC Output and SW Waveform

$V_{PVIN} = 24\text{ V}$, $R_{ADDR} = (\text{open})$

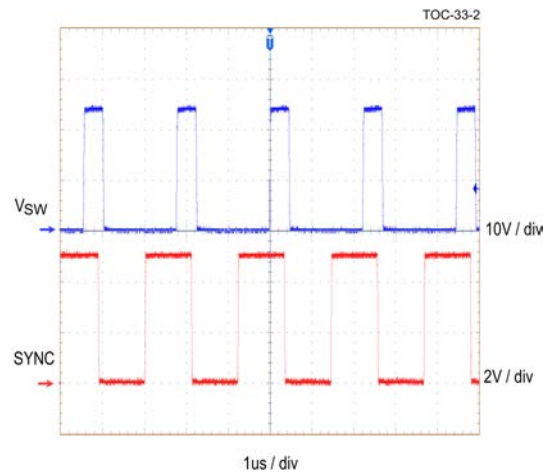

Figure 43. Clock-slave: SYNC Input and SW Waveform

$V_{PVIN} = 24\text{ V}$, $R_{ADDR} = 50\text{ k}\Omega$

Device Functions

Overview

The ACT41000 device is a wide input / output voltage, easy to use, stable and robust step-down (buck) switching regulator IC.

The device truly supports plug-and-play operation by following the recommended schematic from the evaluation kit (EVK) design. This EVK operates in entire supported input voltage, output voltage and output current range without changing anything on the EVK board (except tuning a potentiometer for a target output voltage setting).

The device consists of following four major blocks.

- **Main-buck regulator**

The **Main-buck Regulator** is a 4 A, synchronous, step-down DC-DC converter, featuring on-the-fly programming voltage and current-limit reference generators.

- **Mini-buck regulator**

The **Mini-buck Regulator** is a 5 V output, 350 mA, always-ON, step-down DC-DC converter.

- **Auxiliary (AUX) LDO regulator**

The **Auxiliary LDO** is a programmable output voltage, 20 mA low drop-out (LDO) linear regulator.

- **Control Logic**

The **Control Logic** is a state-machine (STM) logic and I²C interface controller

Functional Block Diagram

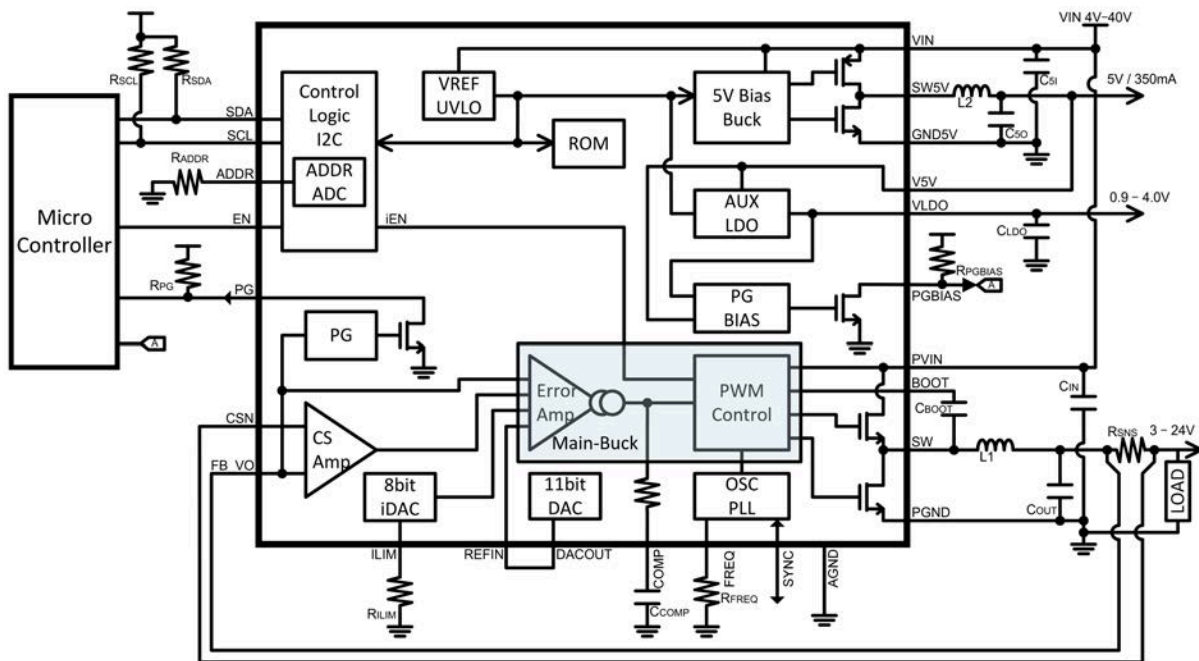

Figure 44. Functional Block Diagram

Control Logic

The ACT41000 device integrates a logic block that controls entire behavior of the device in a manner of state-machine (STM).

At a higher level, the STM consists of nine major status as shown in Table 1.

Table 1. Major States in STM

State	Description	IN	OUT
Normal State			
No Power	No power at the VIN pin.	any state @Power Removed, UVLO, or OVLO	Bias Ramp @Power Attached
Bias Ramp	Power at the VIN pin, bias blocks ramping up.	No Power @Power Attached	R_{FREQ} Check @Mini-buck UP
Bias Ready	Bias blocks ready, waiting for main-buck enable. PGBIAS = logic-H	R_{FREQ} Check @PGBIAS↑	Main-buck Ramp @EN↑
Main-buck Ramp	Main-buck enabled and ramping up. PGBIAS = logic-H	Bias Ready @EN↑	Main-buck ON @PG↑
Main-buck ON	Main-buck is up and running. PGBIAS = logic-H, PG = logic-H	Main-buck Ramp @PG↑ or Main-buck Servo @Servo Complete	Main-buck Servo @Register Change
Servo	Main-buck is up and running, changing output voltage or current target. PGBIAS = logic-H, PG = logic-L	Main-buck ON @Register Change	Main-buck Ramp @Servo Complete
Protection States			
Bias Reset	Critical error in bias blocks, waiting to reset. See Protection Level 2 .	any Normal State @Mini-buck OCP, OVP, UVP, @AUX LDO UVP, @R _{FREQ} Out of Range, @Hard TSD	Bias Ramp @t _{D(RESET)} Time-out
R_{FREQ} Check	Waiting for valid R _{FREQ} . See R_{FREQ} Protection .	Bias Ramp @(Mini-buck Up)	Bias Ready @R _{FREQ} Validated
Main-buck Shutdown	Main-buck disabled, or in error to latched-OFF. See Protection Level 3 .	any state EN=H @iEN↓ @Main-buck UVP(Latch-off) @SYNC Input Error Latch-off @Over-Voltage Protection @Over-Current Protection	Bias Ready @Shutdown Completed
Main-buck Error	Main-buck in error to auto-restart. See Protection Level 4 .	any state EN=H @Main-buck UVP(Hiccup) @SYNC Input Error Hiccup @Soft TSD	Main-buck Ramp @Hiccup Time-out or Bias Ready @iEN↓

The STM controls the device by the [State Diagram](#) below.

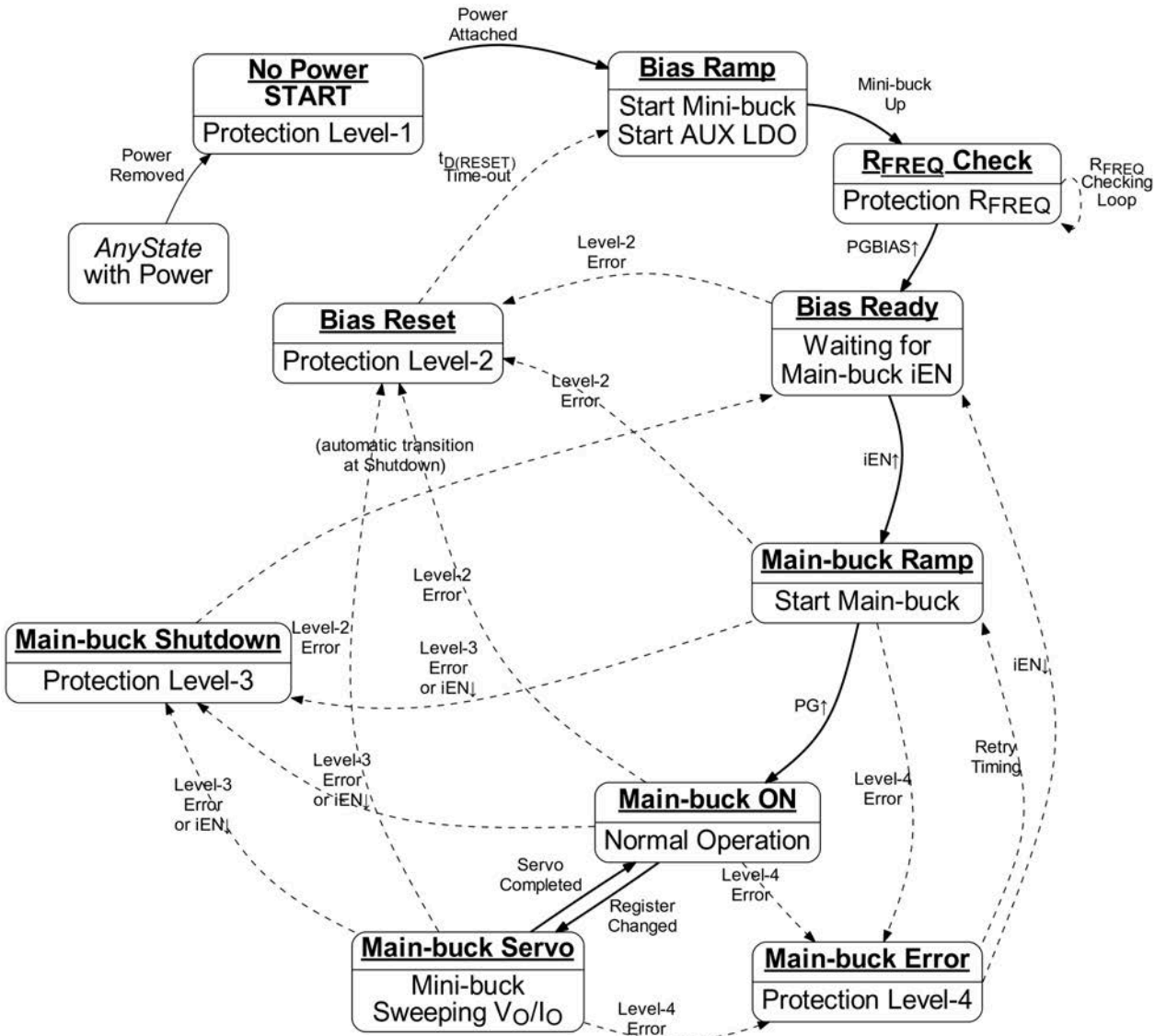



Figure 45. State Diagram

I²C Interface

This I²C block offers a detailed control interface of the ACT41000 device to a host controller device. Through-out the I²C interface (at the SCL and SDA pins), the host device can

1. read various status bits of the device,
2. write various setting bits to control behaviors of the device and read back those setting bits.

 The I²C block is fully activated and ready (to communicate) when the **PGBIAS Indicator Output** becomes logic-H (good).

See [I²C Registers](#) for contents and meaning of the I²C registers. This section explains how to access, how to program these registers.

The device complies with the I²C-bus specification (UM10204).

The SCL and SDA pins are open-drain and a pair of pull-up resistors are required.

See [SCL/SDA Pull-up Resistance](#) for the resistor value selection.

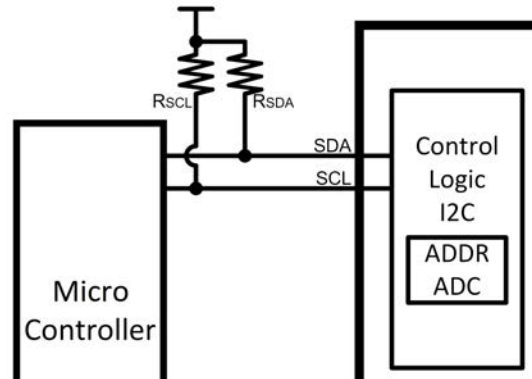

Figure 46. I²C Block

I²C Address Selection

By sensing the value of the R_{ADDR} resistor between the ADDR pin and the ground, the I²C block selects one of six I²C address options, so to avoid address collisions when using multiple ACT41000 devices sharing one I²C bus. See Figure 46. This I²C address selection is directly tied to a selection of the Role of Clock Generator and columns "Clock Role", "SYNC pin" and "SYNC Polarity" in the Table 2 are there for the Clock Generator block.

Table 2. I²C Address with Clock Role

R _{ADDR}	I ² C Address (START)...MSB...LSB...(R/W bit)	Clock Role	SYNC pin	SYNC Polarity
GND Short	00 01 00 0	Stand-alone	Disabled	N/A
20 kΩ	00 01 00 1	Clock-slave	Input	SYNC↑
30 kΩ	00 01 01 0	Clock-slave	Input	SYNC↓
40 kΩ	00 01 01 1	Clock-slave	Input	SYNC↑
50 kΩ	00 01 10 0	Clock-slave	Input	SYNC↓
(open)	00 01 10 1	Clock-master	Output	N/A

I²C Protocol Implementation

The I²C implementation of the device is explained in the Figure 47.

 The Figure 47 is a scalable drawing, can be zoomed in on a PDF reader software or can be printed in a large size paper, for an ease of readability.

In the Figure 47, there are four different scenarios I²C READ or WRITE command sequences. From left to right in the figure (or from top to bottom in a landscape view), these sequences are shown.

1. "One byte WRITE" to a register
2. "Multi-byte WRITE" to registers
3. "one byte READ" from a register, plus another "one byte READ" without setting a target read register
4. (folded back, remaining portion of "3. one byte READ") followed by (folded back, remaining portion of "5. multi-byte READ")
5. "Multi-byte READ" from registers

I²C One byte WRITE

Writing one byte of data into a target register is completed by one 3-byte I²C WRITE command.

The one byte WRITE command byte format is

1. I²C START
2. I²C ACT41000 (target) device address
3. One zero bit for "write"
4. I²C ACK from the ACT41000
(This is the end of the 1st byte.)
5. Target ACT41000 register address
(See Table 6.)
6. I²C ACK from the ACT41000
(This is the end of the 2nd byte.)
7. Register value to write
8. I²C ACK from the ACT41000
(This is the end of the 3rd byte.)
9. I²C STOP

I²C Multi-byte WRITE

Writing multi-byte of data into target registers is completed by one multi-byte I²C WRITE command.

The multi-byte WRITE command byte format is

1. I²C START
2. I²C ACT41000 (target) device address
3. One zero bit for "write"
4. I²C ACK from the ACT41000
(This is the end of the 1st byte.)
5. The first/starting target ACT41000 register address, **assume the address is "N"** (See Table 6.)
6. I²C ACK from the ACT41000
⇒ See "Reg Pointer" that the device sets the target register to "N", at the timing of the ACK.
(This is the end of the 2nd byte.)
7. Register value to write to the "N" register
8. I²C ACK from the ACT41000
⇒ See "Reg Pointer" that the device automatically increments the target register at the timing of the ACK. So the next write data goes to "N+1".
(This is the end of the 3rd byte.)
9. Register value to write to the "N+1" register
10. I²C ACK from the ACT41000
⇒ Another "Reg Pointer" increment to "N+2" at the ACK.
(This is the end of the 4th byte.)
11. Register value to write to the "N+2" register
12. I²C ACK from the ACT41000
⇒ Another "Reg Pointer" increment to "N+3" at the ACK, though the "N+3" is not used in this example.
(This is the end of the 5th byte.)
13. I²C STOP

I²C One byte READ

Reading one byte of data from a target register is completed by a combination of

- a. one 2-byte I²C WRITE command and
- b. one 2-byte I²C READ command.

The one byte READ command sequence is

1. I²C START
2. I²C ACT41000 (target) device address
3. One zero bit for "write"
4. I²C ACK from the ACT41000
(This is the end of the 1st byte in "WRITE".)
5. Target ACT41000 register address, **assume the address is "N"**
(See Table 6.)
6. I²C ACK from the ACT41000
⇒ See "Reg Pointer" that the device sets the target register to "N", at the timing of the ACK.
(This is the end of the "WRITE" command.)
7. I²C REPEATED START
8. I²C ACT41000 (target) device address
9. One high bit for "read"
10. I²C ACK from the ACT41000
(This is the end of the 1st byte in "READ".)
11. The ACT41000 device send out the requested register data from "N"
⇒ Note that at 5th SCL of this data sending action, the device increments the "Reg Pointer" value to "N+1". Whether this byte data is successfully sent out or not (like a case of the host cancel the communication by a sudden STOP), the pointer is incremented at the 5th SCL.
12. I²C NACK from the host device
(This is the end of the "READ" command.)
13. I²C STOP
(This is the end of one byte "READ" sequence.)
⇒ Now, see what happens just sending a "READ" command without a leading "WRITE" command setting a target register. There may be some commands on this bus where "other slave devices" involved (not this device).
14. I²C START
15. I²C ACT41000 (target) device address
16. One high bit for "read"
17. I²C ACK from the ACT41000
(This is the end of the 1st byte in "READ".)
18. The ACT41000 device send out the register data from "N+1"
⇒ Here is the key point in this example. The "Reg Pointer" stays at "N+1" from the step "11." So just sending a "READ" command without a "WRITE" command results in reading a "next register" from the last time.
19. I²C NACK from the host device
(This is the end of the 2nd "READ" command.)
20. I²C STOP

This example "14...20" illustrates that it requires a pair of WRITE and READ commands to access a certain register repeatedly. Because every time a READ action happens the device increments the "reg pointer", a WRITE command is required to reset the "reg pointer".

I²C Multi-byte READ

Reading multi-byte of data from target registers is completed by a combination of

- a. one 2-byte I²C WRITE command and
- b. one multi-byte I²C READ command.

When sending multiple bytes in a READ command, the device automatically increment the target register one-by-one at the timing of 5th SCL as explained in the [I²C One byte READ](#) section.

The multi-byte READ command sequence is

1. I²C START
2. I²C [ACT41000](#) (target) device address
3. One zero bit for "write"
4. I²C ACK from the [ACT41000](#)
(This is the end of the 1st byte in "WRITE".)
5. Target [ACT41000](#) register address, **assume the address is "N"**
(See [Table 6.](#))
6. I²C ACK from the [ACT41000](#)
⇒ See "*Reg Pointer*" that the device sets the target register to "N", at the timing of the ACK.
(This is the end of the "WRITE" command.)
7. I²C REPEATED START
8. I²C [ACT41000](#) (target) device address
9. One high bit for "read"
10. I²C ACK from the [ACT41000](#)
(This is the end of the 1st byte in "READ".)
11. The [ACT41000](#) device send out the requested register data from "**N**"
⇒ Because the "*Reg Pointer*" is "N" at the beginning of this byte, the device sends out data from "N". In parallel, the device increments the "*Reg Pointer*" to "N+1" at 5th SCL.
12. I²C ACK from the host device to continue reading data
(This is the end of the 2nd byte in "READ".)
13. The [ACT41000](#) device send out the "**N+1**" data
⇒ The "*Reg Pointer*" is "N+1" at the beginning of this byte, the device sends out data from "N+1". In parallel, the device increments the "*Reg Pointer*" to "N+2" at 5th SCL.
14. I²C ACK from the host device to continue reading data
(This is the end of the 3rd byte in "READ".)
15. The [ACT41000](#) device send out the "**N+2**" data
⇒ Another "*Reg Pointer*" increment.
16. I²C NACK from the host device
(This is the end of the "READ" command.)
17. I²C STOP

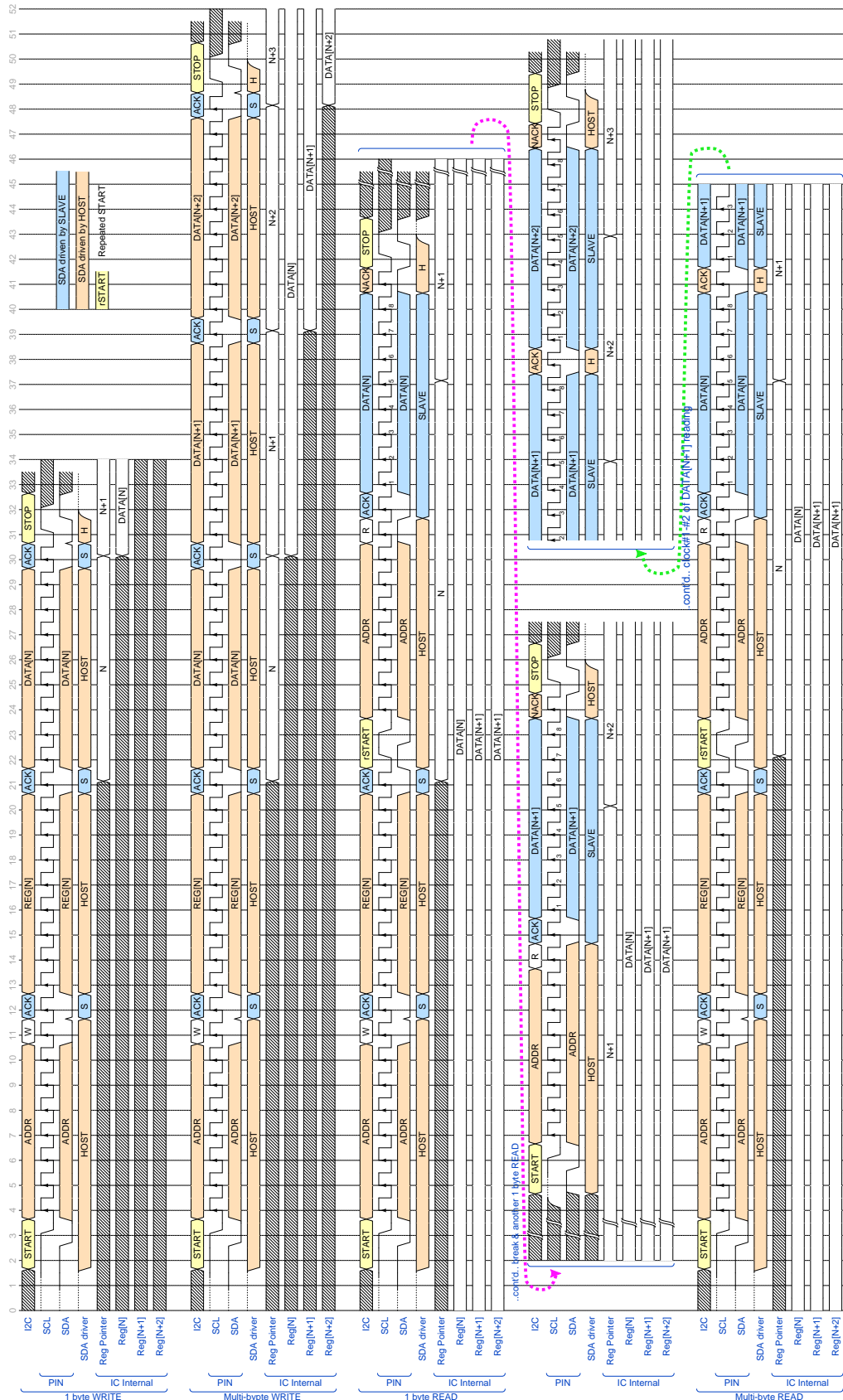

Figure 47. I²C Communication Waveforms (supports zoom in from a PDF viewer)

Under-Voltage Lock-Out

The Under-Voltage Lock-Out (UVLO) function prevents the [ACT41000](#) device working under too low input voltage at the VIN pin. As the VIN pin is connected to the PVIN pin on a PCB, the UVLO monitors PVIN too.

When the VIN pin voltage is below the $V_{IT(UVLO)}$ threshold, the device disables all the functions but this UVLO circuit. During this UVLO period, the device minimizes power consumption and wait for the VIN pin voltage rises into a valid range.

When the VIN pin voltage exceeds the $V_{IT(UVLO)}$ threshold, the device starts working, by following the [Control Logic](#) state-machine. Once the UVLO released, the device keeps working as long as VIN pin voltage maintains higher than the $V_{IT(UVLO,fall)}$ threshold that has a hysteresis from the $V_{IT(UVLO)}$ value.

Over-Voltage Lock-Out

The Over-Voltage Lock-Out (OVLO) function prevents the [ACT41000](#) device working from too high input voltage at the VIN pin. As the VIN pin is connected to the PVIN pin on a PCB, the OVLO monitors PVIN too.

When the VIN pin voltage exceeds the $V_{IT(OVLO)}$ threshold, the device disables all the functions but this OVLO circuit. During this OVLO period, the device minimizes power consumption and wait for the VIN pin voltage decrease back into a valid range.

When the VIN pin voltage gets back normal (under $V_{IT(OVLO,fall)}$), the device starts working, by following the [Control Logic](#).

The [Reg01\[0\]](#) bit is set logic-H to indicate this error.



This OVLO does not protect the device from any potential damage caused by over-voltage events. See [Note of Absolute Maximum Rating](#).

The OVLO is only intended to reduce a risk of a chain-reaction that the VIN/PVIN over-voltage event triggers by disabling all output rails of the device.

Factory Programmed ROM

The [ACT41000](#) integrates a read-only memory (ROM) block and that is programmed at its factory test. The data contents of the ROM configure various behaviors of the device and also some of the contents are default values of I²C registers. When the [Under-Voltage Lock-Out](#) released, the [Control Logic](#) state-machine activates the ROM block as its first step and the STM configures itself according to the ROM values.

See [Factory Programming Options](#).

BIAS Blocks

The [ACT41000](#) employs several bias voltage and bias current reference circuits those are necessary to maintain proper operations of regulator blocks. When the [Under-Voltage Lock-Out](#) released, the [Control Logic](#) state-machine activates these reference and bias circuits before starting the [Mini-buck Regulator](#).

Mini-buck Regulator

Most of ACT41000 device circuit blocks are designed to operate under a 5 V supply from the V5V pin and this 5 V mini-buck switching regulator generates the 5 V bias at the $V_{O(V5V)}$ target. The mini-buck employs an internally compensated, constant ON time (COT) control.

The mini-buck supplies up to 350 mA of output current by step-down converting power from the VIN pin. From the SW5V pin to the GND5V pin, a Mini-buck LC Output Filter is required. The output of this LC filter is connected to the V5V pin.

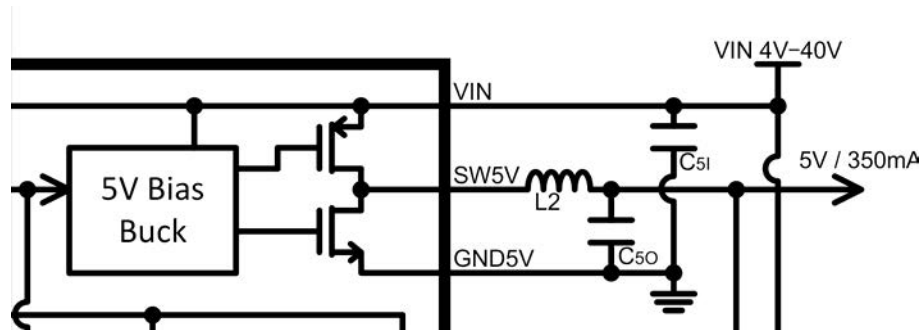

Figure 48. Mini-buck Regulator with an LC Output Filter

⚠ The V5V pin is the supply of control circuits in the Main-buck Regulator and characterized at 5.0 V. The device is designed to be functional down to the $V_{UV(PV5V)}$ threshold but near 4 V supply may not deliver its full performance. A short event at the V5V pin may cause a potential damage.

Mini-buck Enable

The mini-buck regulator generates a fundamental 5 V bias supply of the entire device operation, by default, the Control Logic state-machine enables the mini-buck as soon as both Under-Voltage Lock-Out and Over-Voltage Lock-Out are released. And the mini-buck keeps ON all the time.

V5V, External 5V Supply

When there is a 5 V power supply always available in target systems, the mini-buck can be disabled by setting the I²C Reg09[1] to logic-L to save power loss from its switching.

Mini-buck Power-Good

Whether the mini-buck is enabled or disabled, there is a voltage comparator monitoring the V5V pin to the $V_{IT(V5V)}$ target. See PGBIAS Indicator Output.

Mini-buck Soft-start

The mini-buck regulator executes a soft-start (slow-start) operation when enabled so to avoid in-rush current. This soft-start time is specified by the $t_{SS(V5V)}$ parameter and the device sweep its internal reference voltage from 0% to 100% in the $t_{SS(V5V)}$ period.

During this soft-start period, the mini-buck forces to use, so called, pulse-skip operation so to achieve smooth ramp up of the output voltage and it ignores the I²C Reg0F[5] setting.

Mini-buck Start-up into Pre-biased Output

The mini-buck supports a start-up into a pre-biased output without any huge discharge current from the output.

Without this feature, a regulator circuit may discharge huge amount of current from its output capacitance so to force the output voltage closer to a reference voltage target of its soft-start operation during the internal reference voltage is lower than the pre-biased output by starting from 0%.

See Mini-buck Soft-start.

By preventing its switching operation until the reference target of the soft-start reaches to its pre-biased level, the ACT41000 device avoids the discharge event and achieves a smooth ramp up of the 5 V bias.

Mini-buck Switching Operations

Mini-buck Forced Continuous Conduction Operation

By setting I²C Reg0F[5] to Logic-H, the device operates in a forced continuous conduction mode (FCCM). With this FCCM operation, the regulator maintains its switching frequency to meet the $f_{SW(V5V)}$ target. This $f_{SW(V5V)}$ parameter ensures that its operation frequency do not interfere with AM radio frequency by staying above the AM band.

Mini-buck Pulse-skip Operation

By setting I²C Reg0F[5] to Logic-L, the device operates in a pulse-skipping mode, or so-called, in a light-load efficiency mode.

When its load current goes low, the inductor (coil) current starts flowing in reverse direction (negative current). As the regulator detects continuous reverse current flow cycles, it activates the pulse-skip operation by blocking the reverse current flow.

By blocking a reverse current flow, an energy amount delivered during one switching period is bigger than the one period energy amount of FCCM operation and the output has a bigger ripple voltage. This bigger ripple results in less switching events to reduce power loss related to a switching action. So it improves its conversion efficiency.

 | During this pulse-skip operation, its switching frequency may stay inside AM radio frequency band.

Mini-buck 100% Duty Operation

When the VIN pin voltage is close to the target output voltage $V_{O(V5V)}$, the mini-buck gets into 100% duty mode by setting I²C Reg0F[7].

Without this 100% duty mode (disabled), the device is designed to output a minimum OFF period at each cycle, even though its internal PWM comparator continuously demands more ON duty. This minimum OFF pulse helps to stay at its target switching frequency but it is not desirable when the input voltage is very close to the output as the output voltage starts dropping.

When the 100% duty mode is enabled, the device stops forcing the minimum OFF pulse and the high-side FET maintains ON for multiple cycles without turning OFF as long as the PWM comparator indicates low feedback voltage. This 100% duty operation helps bringing the output voltage close to the input.

Reg03[5] is set logic-H to indicate that the regulator is in 100% duty operation.

 | This 100% duty operation lowers its switching frequency and may stay at AM radio frequency band.

Mini-buck Spread-spectrum Operation

The mini-buck provides a spread-spectrum switching frequency control by setting I²C Reg0F[6].

By activating the spread-spectrum function, the regulator modulates its switching frequency in the range of the $f_{SPSP(V5V)}$ parameter and it repeats this frequency dithering action by the $N_{SPSP(V5V)}$ times of switching period. The spread-spectrum operation improves its EMI performance by lowering noise peaks.

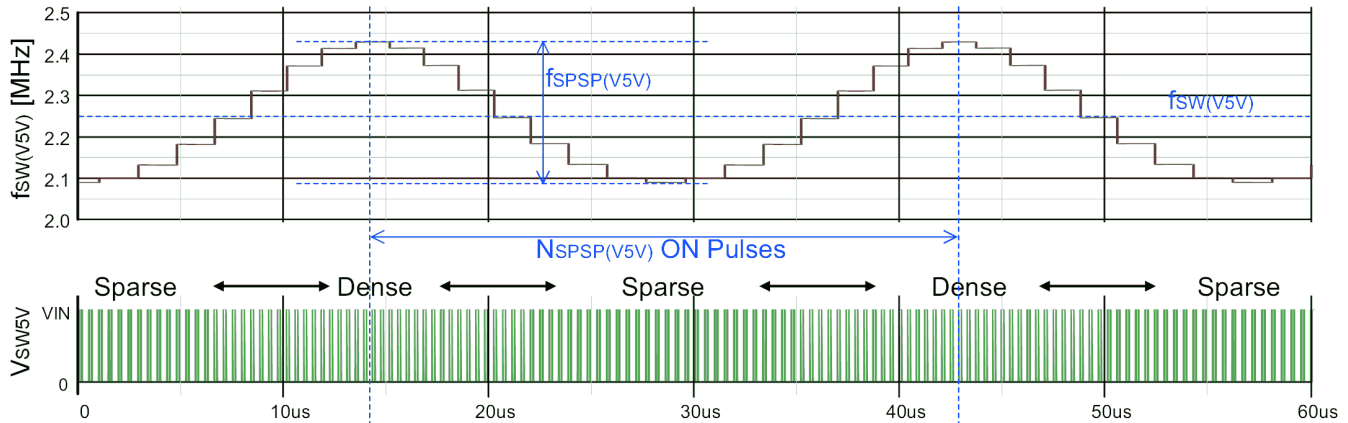
Figure 49. Mini-buck Regulator Spread-spectrum Operation

Mini-buck EMI Tune-up

For the purpose of improving its EMI performance, this mini-buck provides programmable switching node slew rate. By changing the I²C Reg0F[4:3] for the high-side gate and I²C Reg0F[2:1] for the low-side gate, an application system designer can balance the tradeoff between its power conversion efficiency and its EMI noise level. By selecting slower transient rate, the noise performance improves; faster transient rate improves the efficiency.

See Table 30 for the high-side gate available options and see Table 31 for the low-side gate available options.

Mini-buck Over-Current Protection

The over-current protection (OCP) limits its output current below the $I_{OCP(V5V)}$ threshold so to protect integrated FET devices. When the output current exceeds this threshold, the device triggers the over-current protection.

The Reg02[2] is set logic-H to indicate this error.

See Executing Protections for the execution of this protection.

Mini-buck Over-Voltage Protection

The over-voltage protection (OVP) monitors and maintains the V5V pin voltage not to exceed the $V_{OVP(V5V)}$ threshold. For any reason, it exceeds the threshold, the device triggers the over-voltage protection.

The Reg02[1] is set logic-H to indicate this error.

See Executing Protections for the execution of this protection.

Mini-buck Under-Voltage Protection

The under-voltage protection (UVP) monitors the V5V pin voltage at the drops the $V_{UVP(V5V)}$ threshold. For any reason, it falls below the threshold, the device triggers the under-voltage protection.

The Reg02[0] is set logic-H to indicate this error.

See Executing Protections for the execution of this protection.

To avoid triggering this under-voltage protection during its start-up period, the device masks this protection for a timer period of the $t_{D(V5V,mask)}$ parameter when the Mini-buck Soft-start procedure starts. As this $t_{D(V5V,mask)}$ timer expires, the device activates this under-voltage protection.

Auxiliary LDO

For the purpose of supporting one another small power rail, the ACT41000 integrates an auxiliary 20 mA LDO. This AUX LDO is powered by the V5V pin and its output voltage is regulated at the $V_{O(VLDO)}$ target. Between the VLDO pin and the GND5V pin, an **AUX LDO Output Capacitors** is required.

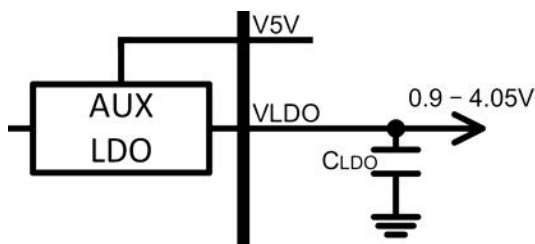

Figure 50. AUX LDO Regulator

AUX LDO Enable

The AUX LDO is activated automatically when the V5V pin voltage exceeds the $V_{IT(V5V)}$ threshold. See **Mini-buck Regulator**. In case of application where this power rail is not needed, the AUX LDO can be disabled by setting the I²C **Reg09[0]** to logic-L to save power.

AUX LDO Soft-start

To avoid a big inrush current, the AUX LDO execute a soft-start procedure. This soft-start sweeps its reference voltage from 0% to 100% in the $t_{SS(LDO)}$ target period.

AUX LDO Power-Good

There is a comparator monitoring the VLDO pin voltage. The output signal from this comparator is device internal. This comparator does trigger no event in the **Control Logic** state-machine "main" sequence flow but, once the AUX LDO is activated, it can trigger an "error" flow after the **AUX LDO Soft-start** operation completed.

AUX LDO Output Voltage Programming

The output voltage of the AUX LDO is programmable from 0.9 V to 4.05 V in 50 mV step by the I²C **Reg0D[5:0]**. See **Table 26** for a target code to program and this table is calculated by the **Eq.(1)**.

$$V_{LDO} = 0.9V + 50mV \times (\text{Reg0D}[5 : 0]) \quad (1)$$

It's default value is stored in the **Factory Programmed ROM**. See **Factory Programming Options**.

AUX LDO Over-Current Protection

The over-current protection (OCP) limits its output current not to exceed the $I_{OCP(VLDO)}$ threshold. When it exceeds, the AUX LDO reduces the output current in a fold-back manner. Because of this fold-back current action, the VLDO pin voltage eventually decreases to hit **AUX LDO Under-Voltage Protection**.

AUX LDO Under-Voltage Protection

The under-voltage protection (UVP) monitors the VLDO pin voltage at the $V_{UVP(VLDO)}$ threshold. For any reason, it falls below the threshold, the device triggers the under-voltage protection.

See **Executing Protections** for the execution of this protection.

PGBIAS Indicator Output

The PGBIAS pin is a dual role status indicator output. The PGBIAS is an open-drain type output and it requires a pull-up resistor. See [PGBIAS/PG Pull-up Resistance](#) for its value selection.

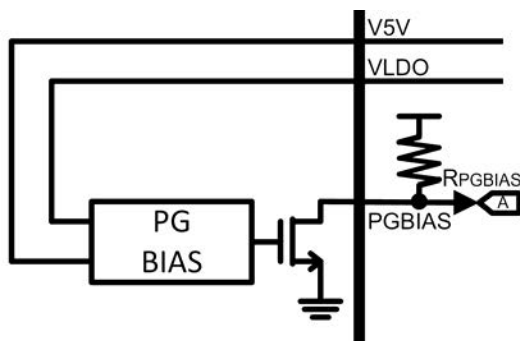

Figure 51. PGBIAS Block

Bias Block Power-good

Before activating the [Main-buck Regulator](#), the device needs to start-up all the supporting bias blocks those includes [Mini-buck Regulator](#), [Clock Oscillator](#) and so on. Based on various internal block status signals, the PGBIAS pin indicates whether the device is ready to activate the Main-buck or not.

When the device is ready to activate the main-buck, the PGBIAS pin becomes logic-H. That means the PGBIAS pin at logic-L indicates it's not ready.

And also the PGBIAS pin indicates the [I²C Interface](#) block is ready.

PGBIAS Delay Time

There is a programmable time delay from an internal timing the device ready to release the PGBIAS to an actual PGBIAS rising edge so to adjust timing between the device and a host micro-controller.

This delay is set by the [I²C Reg08\[4:3\]](#). See [Table 17](#) for available options.

Interrupt Output

The PGBIAS pin is double purposed to output an interrupt signal to a host micro-controller.

The device can disable this interrupt output by setting the [Reg08\[5\]](#) logic-H. With this bit at logic-H, the device only output the [Bias Block Power-good](#) signal.

Because it is invasive to certain micro-controllers those cannot program to distinguish a "power-good or power-not-good" signal from an interrupt, this double purposed interrupt output function is disabled by default.

When any bits in [Reg01](#) and [Reg02](#) becomes logic-H from logic-L, this transition generates an interrupt event. This interrupt event causes a repeated narrow logic-L pulses from the PGBIAS pin. A timing sequence of this interrupt event indicator is described in this list.

1. Starting from PGBIAS is at logic-H (good).
2. Output 10 μ s of logic-L pulse at the PGBIAS pin and return back to logic-H.
3. Start a 480 μ s timer and waits for an [I²C](#) read command to the register, causing this interrupt, from an [I²C](#) host.
4. When a read command comes in, clear the [Reg01](#) and [Reg02](#) and complete the interrupt sequence.
5. If there's no read command, repeat "2."

This sequence is shown in [Figure 52](#).

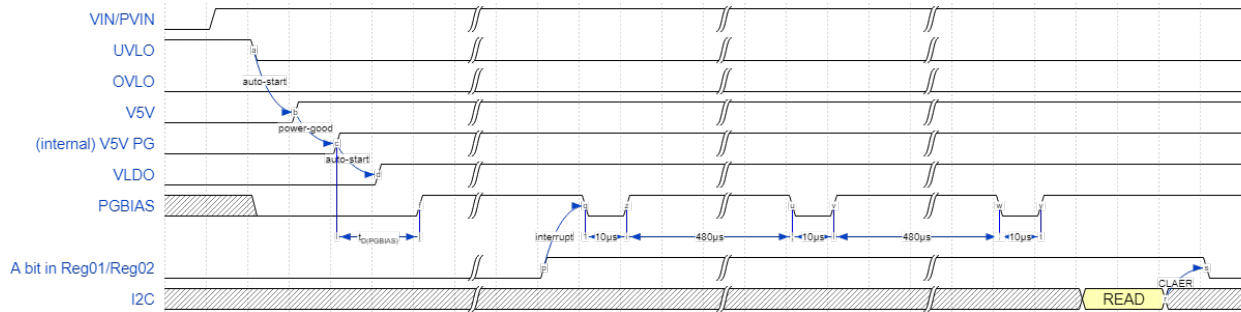
Figure 52. Interrupt Timing Diagram

When a host micro-controller is programmed to read the I²C registers every time when the PGBIAS pin becomes logic-L, the host can receive and distinguish two types of notifications from the PGBIAS pin: a "power-good or power-not-good" signal and an interrupt signal.

The default value of the Reg08[5] bit is logic-H to disable the interrupt output. To enable the interrupt, a host controller needs to write logic-L at this bit during an initial I²C communication session.

Interrupt with Reset

Many of interrupt trigger events executes the [Reset Sequence](#). As long as the VIN pin voltage is valid, the device is designed to maintain its logic status including register values so that a micro-controller can obtain the cause of a reset after the reboot.

The timing diagram, with a reset sequence involved, is shown in [Figure 53](#).

⚠ Note that the device maintains logic-H value of one or more bits in [Reg01](#) and/or [Reg02](#). That means the device starts sending an interrupt pulse sequence immediately after the reboot event. Further note that the pulse timing of this interrupt sequence is continued, inside the device, from the original trigger event. So the time position of first interrupt logic-L pulse after the reboot is undefined.

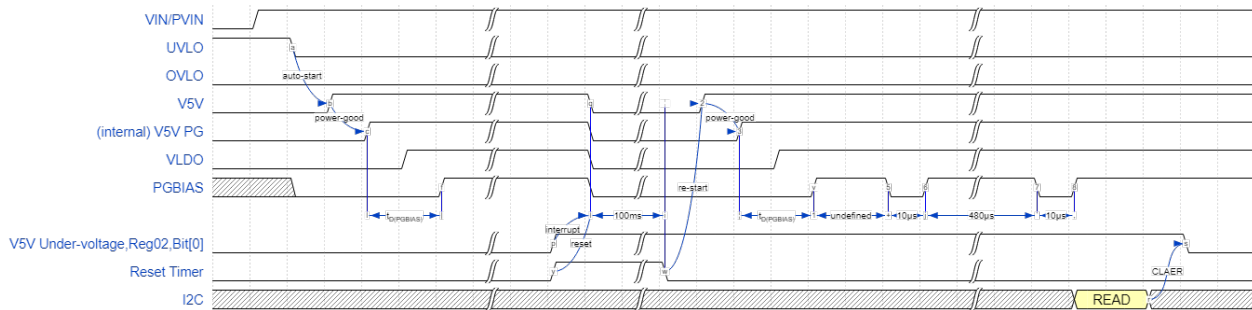
Figure 53. Interrupt Timing Diagram with a Reset

Thermal Protection

The ACT41000 provides a multi-level thermal protection from an over-heating related damages. Both level of protections is working as a thermal shutdown (TSD) but different level of "shutdown" actions applied.

See [Executing Protections](#).

Soft TSD

When the device junction temperature T_J exceeds the $T_{SD(SOFT)}$ threshold, the "soft TSD" triggered.

The "soft TSD" shuts down the [Main-buck Regulator](#) as it is the major source of power loss and causing this high T_J situation. But this level of protection maintains [Mini-buck Regulator](#) and [Auxiliary LDO](#) so that a host microprocessor can figure out the reason of shutdown through the I²C interface.

The [Reg01\[2\]](#) bit is set logic-H to indicate this protection.

The "soft TSD" maintains the OFF state for the $t_{W(HICCUP)}$ period, then it auto-restarts the [Main-buck Regulator](#) when the T_J becomes cooled down below the $T_{SD(OFF)}$ threshold.

Hard TSD

In a case the T_J rises very quickly to hit the $T_{SD(HARD)}$ threshold just after passing $T_{SD(SOFT)}$ threshold, the device shuts down all the blocks by executing the [Reset Sequence](#).

Before hitting this "hard TSD", it is expected that the "soft TSD" prevents T_J rising by stopping the [Main-buck Regulator](#) because the $T_{SD(HARD)}$ is higher than the $T_{SD(SOFT)}$. So only severe T_J rising event causes the "hard TSD" like a sudden output short while supplying the maximum current.

The [Reg01\[3\]](#) bit is set logic-H to indicate this protection.

Clock Generator

The ACT41000 provides a multi-function clock generator for the Main-buck Regulator. This generator consists of a self-running, programmable Clock Oscillator, a phase-locked loop (PLL) Clock Synchronizer to an external clock source, and a Switching Frequency Selector.

Role of Clock Generator

The role of this generator is selected at the same time of the I²C Address Selection. Each of available I²C address options is directly assigned to a role as shown in Table 2. When choosing the I²C address, the role is decided too.

Stand-alone

The stand-alone role is suitable for a situation that only one ACT41000 device is on a PCB. The Clock Oscillator block is used for this roles so to use the oscillator for its own switching timing.

This role configures the SYNC Disabled.

Clock-master

The clock-master role is chosen for a situation that this unit is a master of synchronized operation where multiple units of ACT41000 are on one PCB. The Clock Oscillator block is used for this role so to use the oscillator for its own and sharing switching timing.

This role configures the SYNC to Output Clock.

Clock-slave

The clock-slave role is chosen for a situation that there is an external clock source available to follow. The Clock Synchronizer block is used for this role so to follow an external clock source by synchronizing to it. This type of situations is typically in these 2 cases.

1. Multiple units of ACT41000 are on one PCB and there is a clock-master unit (, not this unit). This unit follows the master.
2. There is a stable system clock source, like a crystal oscillator, on a PCB. This unit follows the oscillator.

This role configures the SYNC to Input External Clock.

The Stand-alone role and the Clock-master role are similar, in terms of running the Clock Oscillator to self generate its own clock. The difference is that the stand-alone role can't not share the clock, on the other hand, the clock-master do share its clock at the SYNC output pin.

Function-wise, the clock-master is a superset of the stand-alone. The benefit of stand-alone role is a further power saving by not driving SYNC pin when a clock sharing is not needed.

Switching Frequency Selector

The R_{FREQ} resistor selects a target operation switching frequency of the Main-buck Regulator. The R_{FREQ} is connected between the FREQ pin and the ground.



The R_{FREQ} resistor must be connected regardless of application usages. The R_{FREQ} resistor should be placed between the FREQ pin and the AGND pin as close as possible with short PCB traces.

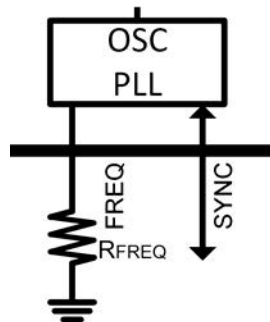

Figure 54. Clock Generator Block with R_{FREQ}

Regardless of Role of Clock Generator, the device detects the R_{FREQ} value for the use of tuning internal loop compensation parameters. This R_{FREQ} detection is performed at the timing the PGBIAS Indicator Output becomes logic-H (good). The loop compensation parameter is a function of the f_{SW(MAIN)}.

When selecting a role with the [Clock Synchronizer](#), use the [Table 3](#) for a target $f_{SW(MAIN)}$ clock at the SYNC input pin.

Table 3. Clock-slave, R_{FREQ} Selection

$f_{SW(MAIN)}$ Range	R_{FREQ}
450 kHz to 600 kHz	178 k Ω
600 kHz to 900 kHz	120 k Ω
900 kHz to 1.20 MHz	85.7 k Ω
1.20 MHz to 1.50 MHz	66.7 k Ω
1.50 MHz to 1.80 MHz	54.5 k Ω
1.80 MHz to 2.10 MHz	46.2 k Ω
2.10 MHz to 2.25 MHz	40.0 k Ω

The [Recommended \$R_{FREQ}\$ Range](#) is between 40 k Ω and 200 k Ω .

When selecting a role with the [Clock Oscillator](#), **follow the [Table 4](#)**.

[R_{FREQ} Protection](#)

To protect the device (trying to) working at a switching frequency value out of supported range, the device validates R_{FREQ} value at the timing of the R_{FREQ} value detection. When R_{FREQ} is out of the [Recommended \$R_{FREQ}\$ Range](#), the device triggers a R_{FREQ} error.

And the [Reg01\[4\]](#) bit is set logic-H to indicate this error.

See [R_{FREQ} Check Loop](#) for the execution of this protection.

[Clock Oscillator](#)

A device of [Clock-master](#) or [Stand-alone](#) role activates this oscillator block.

This oscillator generates a main-buck switching clock signal based on the R_{FREQ} resistor value. The frequency range can be programmed between 450 kHz and 2.25 MHz by following [Eq.\(2\)](#).

$$f_{SW(MAIN)} = \frac{90 \times 10^9}{R_{FREQ}(\Omega)} \quad (2)$$

The [Table 4](#) lists some calculation examples.

Table 4. Clock-master, R_{FREQ} Selection

R_{FREQ}	$f_{SW(MAIN)}$
200 k Ω	450 kHz
...	
85.7 k Ω	1050 kHz
...	
54.5 k Ω	1.650 kHz
...	
40.0 k Ω	2250 kHz

The [Recommended \$R_{FREQ}\$ Range](#) is between 40 k Ω and 200 k Ω .

[SYNC to Output Clock](#)

For the purpose of applications requires a [Clock Synchronizer](#) feature, a [Clock-master](#) device outputs its clock signal generated by the [Clock Oscillator](#) at the SYNC **output** pin as a clock-master.

This output clock signal is used by slave devices.

Note that the SYNC pin is a bi-directional input/output pin. See [SYNC to Input External Clock](#).

SYNC Disabled

A device of [Stand-alone](#) role disables the SYNC pin.
 See [SYNC to Output Clock](#) and [SYNC to Input External Clock](#).

Clock Synchronizer

A device of [Clock-slave](#) role activates this synchronizer block.

In applications where multiple [ACT41000](#) devices are working together, each [Clock Oscillator](#) from multiple devices generate slightly different frequency of clock signals due to a unit-to-unit variations. This situation rises an EMI concern of low frequency beat.

To solve this EMI concern, the clock synchronizer follows one master clock source so to make all the devices working (synchronized) at the timing of this master clock.

The [Clock-slave](#) role paragraph explains two typical scenarios where a clock master is.

SYNC to Input External Clock

The external clock source signal to the synchronizer is applied at the SYNC **input** pin so to follow (synchronize to) an external clock master signal.

Note that the SYNC pin is a bi-directional input/output pin. See [SYNC to Output Clock](#).

SYNC Input Polarity

By synchronizing switching timings of multiple devices reduces the EMI concern, however, it causes multiple devices turning on at the same time to increase transient current noise.

To relieve this "same time ON" situation, the device in the [Clock-slave](#) role can select clock edge to follow the master. The synchronizer is designed to follow either one of

1. a rising edge of the SYNC **input** (SYNC \uparrow), or
2. a falling edge of the SYNC **input** (SYNC \downarrow).

This polarity selection is also done at the timing the I²C address is chosen from the [I²C Address Selection](#).

SYNC Input Watch Dog Timer

In case an input signal at the SYNC pin is unstable, the main buck regulation becomes unstable. To avoid this sort of unreliable SYNC input situations, the device monitors frequency of the external clock source at the SYNC **input** pin. This circuit is a sort of watch dog timer (WDT) structure. This WDT circuit is based on the [Table 3](#) setting. When the input external clock signal is out of range between $\Delta f_{\text{SYNC}(\text{low})}$ and $\Delta f_{\text{SYNC}(\text{high})}$, a "SYNC WDT Error" event is triggered.

The [Reg01\[5\]](#) bit is set logic-H to indicate this error. And the [Reg03\[7\]](#) or [Reg03\[6\]](#) bit indicates whether the input clock is higher or lower the range.

SYNC Input Error Hiccup Operation.

By setting the [Reg09\[2\]](#) bit at logic-L, this WDT repeats a "wait" and "retry" cycle, that is so called a "hiccup" operation. At the first time a WDT event happens, the device disables its switching operation for the $t_{\text{W}(\text{HICCUP})}$ of time period, and then the device tries to restart. If its SYNC input signal becomes stable, the main buck regulator continues working as normal; if the SYNC input is still unstable, the devices goes into another disabled state for another $t_{\text{W}(\text{HICCUP})}$ period to repeat the hiccup operation.

See [Protection Level 4](#) for the execution of this protection.

SYNC Input Error Latch-off Operation.

By setting the [Reg09\[2\]](#) bit at logic-H, the main-buck regulator latches the OFF status at the first WDT event.

See [Protection Level 3](#) for the execution of this protection.

Output Voltage Reference

The ACT41000 integrates a digital-to-analog converter (DAC) for the purpose of generating the reference voltage, used by the Reference Voltage Input block and this DAC output is assigned at the DACOUT pin.

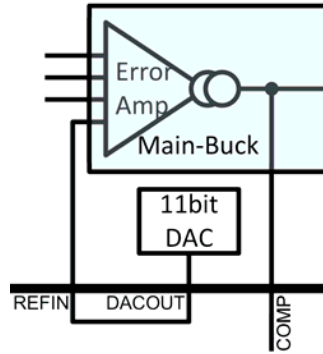

Figure 55. Output Voltage Reference

This DAC converts 11 bit data from Reg0A[7:0] and Reg0B[2:0] based on Eq.(3).

$$\begin{aligned}
 \text{DAC}_{\text{CODE}}[10 : 0] &= (\text{Reg0A}[7 : 0]), (\text{Reg0B}[2 : 0]) \\
 V_{\text{DACOUT}} &= 1.5625(\text{mV}) \times (\text{DAC}_{\text{CODE}}[10 : 0])
 \end{aligned}
 \tag{3}$$

See Table 21 for this bit to voltage conversion table.

- ⚠ Because the device is designed to work with 5 V supply at the V5V pin, so VIN supply close to 4V may not be enough for its full performance even though the device is fully functional.
- ⚠ As shown in Table 21, even though the I2C block accepts it as a valid data, any value above "0x780" is truncated as "0x780" to avoid an over-voltage condition.

Loading New DACOUT Value

An attention is needed how to load the I²C register value into this DAC block. This is a unique situation in the device I²C operation.

Because the 11 bit DACOUT control data are stored in 2 different registers, Reg0A[7:0] and Reg0B[2:0], an I²C host must change these 2 registers one-by-one and there is a timing gap where new target value is half written. This timing gap could be a problem driving the DACOUT into wrong direction. To void this timing gap, there is a special "load command" so to load entire 11 bit without a timing gap.

When an I²C host finishes setting new DACOUT target value on both Reg0A[7:0] and Reg0B[2:0], then the host sets the Reg05[1] bit. A logic-H to this bit triggers the DAC block loads new target value as 11 bit data.

The DAC block only loads new target value at a trigger by this "load command" bit.

See Servo Reference Control and Figure 57.

Output Current Reference

The ACT41000 integrates a current output, digital-to-analog converter (iDAC) for the purpose of generating the reference signal, used by the Programmable Current Limit block and this iDAC current output is assigned at the ILIM pin.

The iDAC converts 8 bit data from the Reg0C[7:0] bits based on Eq.(4).

$$I_{ILIM} = 391(\text{nA}) \times ((\text{Reg0C}[7 : 0]) + 1) \tag{4}$$

See Table 24 for this bit to current conversion table.

In a typical application, an external programming resistor R_{ILIM} is connected between the ILIM pin and the ground. The Programmable Current Limit block uses the voltage generated by the R_{ILIM} and the output current from this iDAC block as shown in the Eq.(5).

$$V_{ILIM} = R_{ILIM} \times I_{ILIM} \tag{5}$$

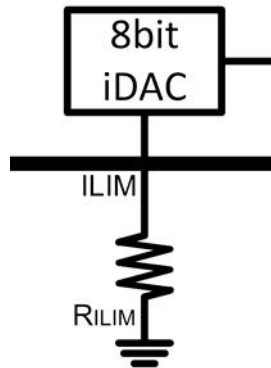

Figure 56. Output Current Reference

Servo Reference Control

For the purpose of smooth, on-the-fly controls of the Main-buck Regulator, the device integrates the servo reference control block between the I²C registers and the digital-to-analog converters. It controls the Output Voltage Reference and the Output Current Reference blocks.

The Figure 57 shows the structure of this servo control. The key components of this servo control are

1. two digital comparators, 11 bit one for Output Voltage Reference and 8 bit one for Output Current Reference, and
2. two up/down counters, 11 bit one for Output Voltage Reference and 8 bit one for Output Current Reference, and
3. a servo clock source and a clock divider.

For the servo block, input data comes from the I²C registers and the outputs from the up/down counters goes to Output Voltage Reference and Output Current Reference. The up/down counters keep incrementing or decrementing its output digital code as long as corresponding digital comparator results are not "A = B" by synchronized to the Servo Clock Divider.

With the servo control, any target value change event to the Output Voltage Reference and/or Output Current Reference are translated into a smooth step-by-step increment or decrement to avoid huge jumps. See On-the-fly Reference Programming.

The servo block can handle changes on both the Output Voltage Reference and Output Current Reference in parallel. For example, while in the middle of the Output Voltage Reference servo, new value set for Output Current Reference results in both references in servo, and vice versa.

This servo block is used in the Main-buck Soft-start too. See Loading New DACOUT Value.

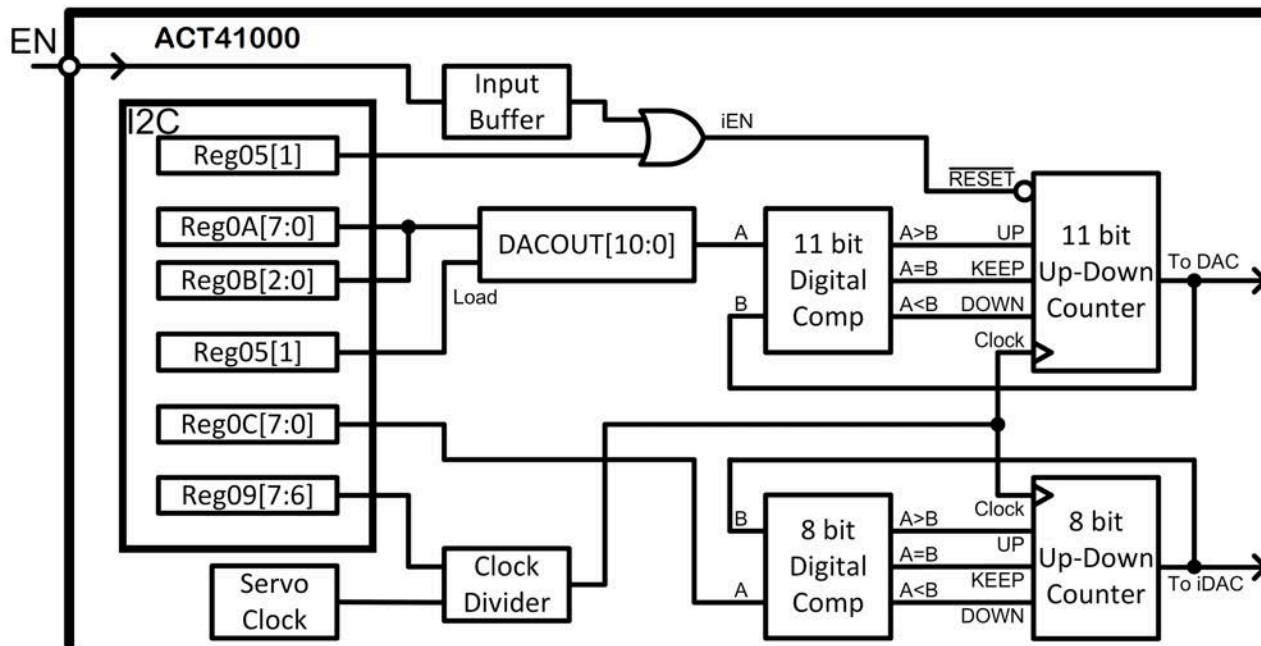

Figure 57. Servo Control Block

Servo Clock Divider

To adjust the speed of servo transition, there is a clock divider between the servo master clock and the up/down counters. it is control by the [Reg09\[7:6\]](#) bits and see [Table 19](#) for available options.

Main-buck Regulator

The main-buck is the main step-down switching regulator of the ACT41000 device.

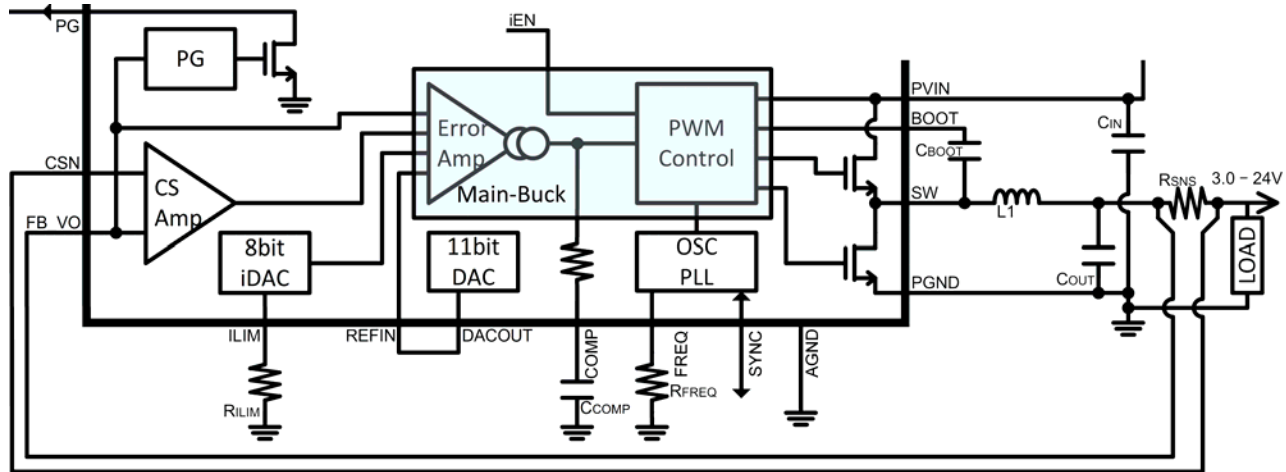

Figure 58. Main-buck Regulator

At a very high level, the SW pin (switching) node voltage is filtered by the output LC filter to have the output voltage. Then, the output voltage is fed back to the FB_VO input to close the regulator control loop.

The main-buck block requires following external components.

- An output LC filter. See [Main-buck LC Output Filter](#).
- A bootstrap capacitor. See [Main-buck Bootstrap Capacitor](#).
- A compensation capacitor. See [Main-buck Compensation Network](#).
- A current limit programming resistor. See [Programmable Current Limit](#).
- A current sense register. See [Output Current Sensing](#).

Main-buck Enable Control

The main-buck regulator is enabled and disabled by this enable control block. From the view point of power sequencing, the input of the main-buck is the iEN signal from this block and the output is the [Main-buck Power-Good](#) signal.

Disable.

When iEN is logic-L, the main-buck is disabled.

The main-buck provides an active discharge function when the [Reg09\[4\]](#) bit is logic-H. During the active discharge, the device activates the [Output Discharge Resistor](#) to force the output near ground level in shorter time. This feature is useful in applications where the output is expected to start from the (near) ground voltage.

When the [Reg09\[4\]](#) bit is logic-L, the main-buck makes the output node high impedance at it disabled condition. Consumption current from load devices discharges the output and, generally, the output voltage value is uncontrolled.

Enable.

When iEN is logic-H, the main-buck is enabled and it regulates the output as described in following sections.

No Controller to Drive the EN pin.

The EN pin has an internal pull-up source as shown in the [Figure 59](#), so the EN pin becomes logic-H by leaving it **open (connected to nothing)** and the main-buck gets enabled every time the [Control Logic](#) comes to the [Bias Ready](#) status.

By using an external delay circuit, the device can support an application specific needs in many flexible ways. See [Timing Control between PGBIAS and EN](#).

EN Input Buffer

The logic input buffer at the EN pin provides a programmable hysteresis capability. As shown in the [Figure 59](#), There are two of 1- μ A current sources at the EN pin where the first 1- μ A element is always connected working as a constant bias and the second 1- μ A element gets connected to the EN pin when its input is logic-H as a hysteresis source.

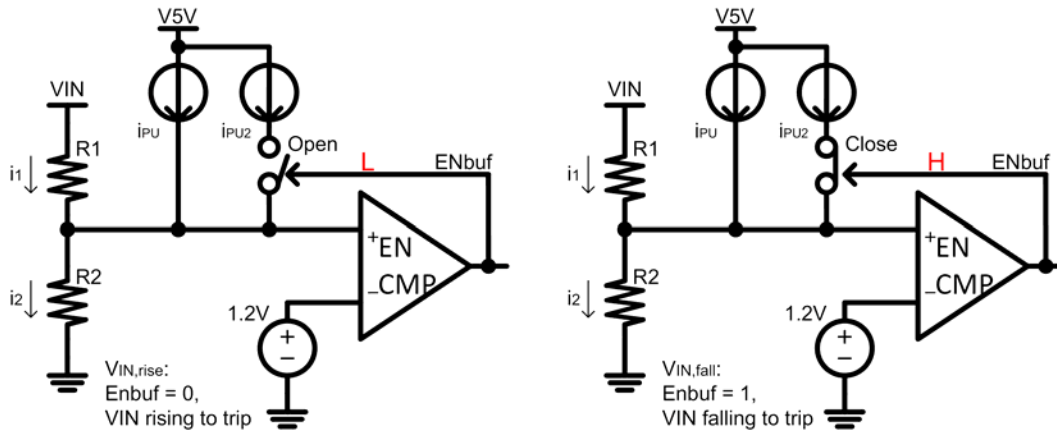

Figure 59. EN Input Buffer

! The **Control Logic** block operates based on its internal clock and a short Logic-L pulse input at the EN pin may not be captured. To ensure valid Logic-L input, at least $t_{LOW(EN)}$ of Logic-L period is required.

Additional UVLO by the EN pin.

A hysteresis voltage generated by the two current sources, in the Figure 59, can be used as a programmable UVLO, in addition to the fixed value **Under-Voltage Lock-Out** that controls the bias blocks. This additional UVLO only controls the main-buck and the target voltage is programmed higher than $V_{IT(UVLO)}$, otherwise the $V_{IT(UVLO)}$ dominates the control. In the Eq.(6), following three calculations are listed.

1. the detecting threshold voltage when VIN is rising
2. the detecting threshold voltage when VIN is falling
3. the hysteresis voltage from "1." and "2."

$$\begin{aligned}
 V_{IN,rise} &= \left(1 + \frac{R_1}{R_2}\right) V_{IT(EN)} - R_1 i_{PU} \\
 V_{IN,fall} &= \left(1 + \frac{R_1}{R_2}\right) V_{IT(EN)} - R_1 (i_{PU} + i_{PU2}) \\
 V_{IN,hysteresis} &= R_1 \times i_{PU2}
 \end{aligned}
 \tag{6}$$

Based on the Eq.(6), some example calculation results are listed in the Table 5.

Table 5. EN pin Hysteresis Example

R1 (kΩ)	R2 (kΩ)	V _{IN,rise} (V)	V _{IN,fall} (V)	Current through R1,R2 (μA) @24V
Smaller Hysteresis Settings				
700	100	8.9	8.2	30
800	100	10.0	9.2	26.7
900	100	11.1	10.2	24
1000	100	12.2	11.2	21.8
Bigger Hysteresis Settings				
1500	250	6.9	5.4	13.7
1500	200	8.7	7.2	14.1
2000	200	11.2	9.2	10.9
1500	150	11.7	10.2	14.6

I²C Enable Bit

The [Reg05\[0\]](#) bit is a second enable signal input to the main-buck. When the [ACT41000](#) device is controlled by an I²C host processor, this host does not need to control the EN pin. This saves one GPIO terminal at the host.

Internal Enable Signal

The [Main-buck Regulator](#) is controlled by a logic OR operation of 2 input signals

1. a logic input signal at the EN pin from the [EN Input Buffer](#) block and
2. a logic setting bit in the I²C register at the [Reg05\[0\]](#) bit.

$$iEN = OR((ENpin), (Reg05[0])) \tag{7}$$

throughout this datasheet, call this logic OR operation result (*iEN*) as an **iEN** signal that is short for an internal EN. When the *iEN* signal becomes logic-H, the main-buck start working. When it reaches its target voltage, the device outputs the [Main-buck Power-Good](#) signal.

Output Discharge Resistor

The device provides a pull down resistor of the R_{DIS} value, from the FB_VO pin to the PGND pin.

This R_{DIS} is activated at two different occasions.

1. Active Discharge at Disable
See [Main-buck Enable Control](#).
2. Active Negative Transition See [Negative Transition with \$R_{DIS}\$](#) .

Reference Voltage Input

The main-buck regulates its output voltage based on the REFIN pin voltage as its reference. In a typical usage, the DACOUT pin, from the [Output Voltage Reference](#) block, is connected to the REFIN pin by shorting these adjacent pins on a PCB as shown in the [Figure 55](#).

The output voltage, sensed by the FB_VO pin, is regulated at eight times of the REFIN voltage as shown in the [Eq.\(8\)](#). By combined with the [Eq.\(3\)](#), the output voltage is controlled by the I²C [Table 21](#) in 12.5 mV step as shown in the [Eq.\(9\)](#). The calculated results from the [Eq.\(9\)](#) is found in the [Table 21](#).

$$V_{O(MAIN)} = 8 \times V_{REFIN} \tag{8}$$

$$V_{O(MAIN)} = 12.5(mV) \times (DAC_{CODE}[10 : 0]) \tag{9}$$

Even though the I2C block accepts it as a valid data, any value below **0x0F0** sets the output voltage below 3.0 V and, by default, the Under-Voltage Protection (UVP) triggers a fault action. See [Programmable Current Limit](#) and [Under-Voltage Protection](#).

External Reference Voltage

It is not necessary to connect the DACOUT and the REFIN pins for the main-buck voltage reference. When a stable and well-regulated reference voltage source is available on a PCB, such external voltage reference can be used in a position of the [Output Voltage Reference](#). The main-buck control loop is designed to follow whatever voltage comes into the REFIN pin by following the [Eq.\(8\)](#).

When the DACOUT pin is not used to feed the REFIN pin, there is no [Main-buck Soft-start](#) function and an external voltage reference driving the REFIN pin needs to ramp up slowly to avoid huge inrush current.

Main-buck Soft-start

The soft-start (or slow-start) function of the main-buck uses the [Servo Reference Control](#) so to avoid inrush current to the output capacitor, at a start-up event.

While the *iEN* is logic-L, the *iEN* signal reset the **11 bit up/down counter** at the \overline{RESET} in the [Figure 57](#). Simply, when the *iEN* becomes logic-H, the *iEN* signal releases the reset and the counter start ramping up to the [DACOUT\[10:0\]](#) target.

During this soft-start period, the main-buck forces to use, so called, pulse-skip operation so to achieve smooth ramp up of the output voltage.

Main-buck Soft-start into Pre-biased Output

The main-buck supports a start-up operation into a pre-biased output so to avoid huge discharge current from the pre-biased output capacitor.

As described in [Main-buck Soft-start](#), in a case of normal start-up ("non" pre-biased output), the soft-start function starts from zero target and the main-buck control loop try to follow the REFIN voltage that is rising by the servo. Here, at the inputs of the [Error Amplifier](#), the reference is higher than the feedback.

In a case of pre-biased output without this "pre-bias" support, until its reference voltage comes to the pre-biased output voltage, the feedback is higher than the reference. So a regulator without the "pre-bias" support tries to pull down its pre-biased output toward the voltage target its reference points. Usually, this results in a huge reverse current flow from its output capacitor.

The soft-start engine of the [ACT41000](#) device is designed to do nothing until the REFIN voltage comes to the pre-biased output voltage.

Error Amplifier

The main-buck has one error amplifier to maintain high feedback loop gain. The feedback input voltage at the FB_VO pin and the reference input voltage at the REFIN pin are compared by the error amplifier and its error output signal is assigned at the COMP pin.

A compensation network is required between the COMP pin and the ground. See [Figure 58](#) and [Main-buck Compensation Network](#).

Valley Current Mode Loop Control

The [ACT41000](#) employs a proprietary valley current mode control to regulate the output voltage. The control maintains its operation at a fixed frequency point for EMI noise sensitive applications. This unique current-mode yields very high loop gain bandwidth and good stability over wide range of its operating conditions.

Main-buck Switching Options

Forced Continuous Current Operation

The device operates in a forced continuous conduction mode (FCCM). With this FCCM operation, the regulator maintains its switching frequency to meet the $f_{SW(MAIN)}$ targets. These $f_{SW(MAIN)}$ parameter ensures that its operation frequency do not interfere with AM radio frequency by staying above the AM band.

Pulse-skip Operation

 This function block is not used in this [ACT41000](#) device option. This is a placeholder for other device options in this product family. See [Ordering Information](#).

100% Duty Operation

When the PVIN pin voltage is close to the target output voltage V_O , the main-buck gets into 100% duty mode by setting the [Reg0B\[7\]](#) bit.

Without this 100% duty mode (disabled), the device is designed to output a minimum OFF period at each cycle, even though its internal PWM comparator continuously demands more ON duty. This minimum OFF pulse helps to stay at its target switching frequency but it is not desirable when the input voltage is very close to the output as the output voltage starts dropping.

When the 100% duty mode is enabled, the device stops forcing the minimum OFF pulse and the high-side FET maintains ON for multiple cycles without turning OFF as long as the PWM comparator indicates low feedback voltage. This 100% duty operation helps bringing the output voltage close to the input.

When keeping the high-side FET ON for a long time period, the bootstrap capacitor voltage becomes lower as a high-side gate driver consumes power from the bootstrap capacitor. To maintain a proper operation of the high-side FET, the bootstrap capacitor needs to be recharged occasionally. This refresh action happens at every eight cycles. This means that, at a worst case, its operation switching frequency becomes one eighth ($1/8 = 12.5\%$) of the target setting.

The [Reg03\[3\]](#) bit is set logic-H to indicate that the regulator is in 100% duty operation. When using this 100% duty operation, consider to increase amount of output capacitance by monitoring the output voltage.

 This 100% duty operation lowers its switching frequency and may stay at AM radio frequency band.

Spread-spectrum Operation

The main-buck provides a spread-spectrum switching frequency control by setting the `Reg0B[6]` bit.

By activating the spread-spectrum function, the regulator modulates its switching frequency in the range of the $f_{SPSP(MAIN)}$ parameter and it repeats this frequency dithering action by the $N_{SPSP(MAIN)}$ times of switching period. The spread-spectrum operation improves its EMI performance by lowering noise peaks.

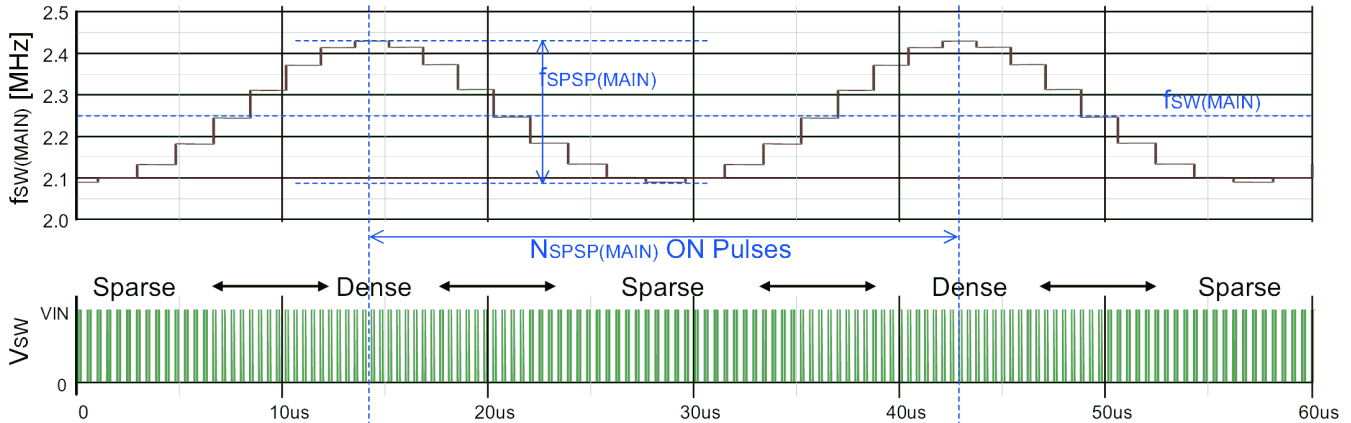



Figure 60. Main-buck Regulator Spread-spectrum Operation

Output Current Sensing

The ACT41000 provides a current sense (CS) amplifier to monitor its output current, I_{OUT} , precisely for the Programmable Current Limit and Over-Current Protection blocks. This CS amp uses the `FB_VO` pin and the `CSN` pin (current sense negative) as its differential inputs and generates a device internal signal, V_{CS} with a gain of 20, by following the Eq.(10). As shown in Figure 58, the `FB_VO` and the `CSN` pins are monitoring an external current sense resistor R_{CS} .

$$\begin{aligned}
 V_{CS}(V) &= (V_{FB_VO} - V_{CSN}) \times 20 & (10) \\
 &= I_{OUT} (A) \times R_{CS} (\Omega) \times 20
 \end{aligned}$$

Programmable Current Limit

 In this datasheet, following three function names refer to clearly different meanings and behaviors of the device.

Programmable Current Limit

The programmable current limit function is a regulation control of the main-buck output current at a programming target value (`CC`: constant-current operation), within a safe operation area (SOA) of the device. This means a continuous operation at this programmable current limit is safe and supported.

Cycle-by-cycle Current Limit

The Cycle-by-cycle Current Limit protection is a hard limit of the main-buck output current. The threshold of this protection is beyond the design and safe operation area of the device. Repeated events of this protection will degrade or damage the device permanently.

Over-Current Protection

The Over-Current Protection (OCP) is a superset of the cycle-by-cycle current limit protection. The OCP is also beyond the design and safe operation area of the device and repeated OCP events will degrade or damage the device permanently.

In addition to the normal voltage regulation (or "CV", constant voltage regulation), the device provides very tightly regulated current limit control (or a constant current "CC" control) to the V_{CCMODE} target when the `Reg0B[4]` bit is logic-H.

To ensure enough operation headroom, this CC operation gets enabled when the `FB_VO` pin input voltage exceeds the $V_{IT(CC, rise)}$ target. And it gets disabled when the `FB_VO` voltage goes below the $V_{IT(CC, fall)}$ target.

While the output current is low enough, the current limit block does nothing and stays in the normal CV regulation. When the output current increases to hit the target constant current value, this block regulates the output current constant by allowing its output voltage droops. This voltage drop may trips the Main-buck Power-Good or Under-Voltage Protection blocks.

Rephrasing above paragraph with equations Eq.(4), Eq.(5) and Eq.(10), the current limit block regulates the output to meet the Eq.(11).

$$\begin{aligned}
 V_{CS} &\leq V_{ILIM} \\
 I_{OUT} \times R_{CS} \times 20 &\leq R_{ILIM} \times I_{ILIM} \\
 I_{OUT} \times R_{CS} \times 20 &\leq R_{ILIM} \times 391(\text{nA}) \times ((\text{Reg0c}[7 : 0]) + 1) \\
 I_{OUT} &\leq 391(\text{nA}) \times ((\text{Reg0c}[7 : 0]) + 1) \cdot \frac{R_{ILIM}}{20 R_{CS}}
 \end{aligned}
 \tag{11}$$

When disabling this programmable current limit function or when programming this current limit higher than 4A, using an additional Schottky diode in parallel with the low-side FET helps better rectification.

! The Eq.(11) illustrates that the current limit accuracy is a function of R_{ILIM}/R_{CS} (actually, it's fully proportional). Even though the device provides accurate CS amp and current limit blocks, total accuracy is fully depending on the R_{ILIM} and R_{CS} accuracy, tolerance control on an application PCB.

CC / CV Interrupt/Monitor

The device is designed to switch between the CV and CC seamlessly. And the device can report its status through the I²C.

For certain applications, a host controller device wants to know the timing of this CC⇌CV transition.

At a transition event, the Reg01[7] bit becomes logic-H to generate an interrupt.

When in CC, the Reg03[4] bit becomes logic-H. When in CV, the Reg03[4] bit becomes logic-L.

! The device is optimized to support battery charging type applications with this CC / CV regulation. A sudden transition from a high current CC operation to a CV operation, like a mechanical switch to disconnect a (high current) load, may cause an event of output voltage overshoot.

Main-buck Power-Good

The PG pin is an indicator output of the main-buck. The PG is an open-drain type output and it requires a pull-up resistor. See PGBIAS/PG Pull-up Resistance for its value selection.

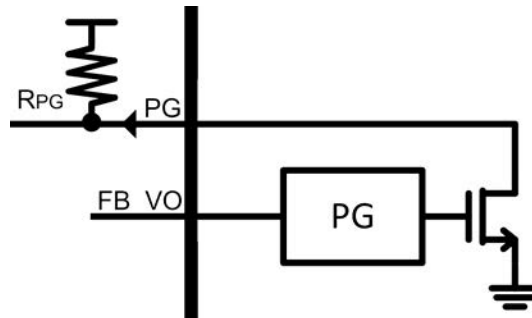

Figure 61. PG Block

When the device is in the Main-buck ON state, this PG pin becomes logic-H and it is logic-L in all the other states. In this statement, the "other states" includes the Servo state. To avoid generating an unstable PG signal, the PG block keeps its output logic-L while the Servo Reference Control is working. Because the Main-buck Soft-start or On-the-fly Reference Programming operation employs the Servo Reference Control, the PG pin becomes logic-L during such operation.

! The PG pin becomes logic-L when executing the Output Voltage Reference servo operation even though the device is in CC regulation. Or it becomes logic-L when executing the Output Current Reference servo in CV regulation. This is because a transition between CV and CC is depending on a load condition and it could happen during a servo period. (The device is just reacting to the load, not actively choosing CV or CC.) To

avoid an inconsistent PG output, the [Servo Reference Control](#) blocks the PG pin regardless of voltage or current target changes.

Main-buck Power-Good Detail

The PG pin indicates the device is in a regulation of either [CV](#) or [CC](#). When the PG pin is "good", the device provides multiple bits for the detail of this power-good operation through the I²C.

The [Reg03\[4\]](#) bit indicates whether the device in [CV](#) or [CC](#).

The [Reg03\[2\]](#) bit indicates whether the device in the CV regulation window of the $V_{IH(VO)}$ and $V_{IL(VO)}$ thresholds.

The [Reg01\[7\]](#) bit indicates a transition between [CV](#) or [CC](#).

Main-buck Power-Good Delay

The PG block has a programmable delay circuit at the output stage of the PG pin. The device can insert a certain delay time from the timing of device internal power-good judgement to actual PG pin transition. This programmable delay helps to build a flexible power sequencing design on a PCB.

The [Reg08\[7:6\]](#) bits controls this delay time and see [Table 16](#) for available options.

On-the-fly Reference Programming

By using the [Servo Reference Control](#) block, the main-buck supports on-the-fly programming of the [Output Voltage Reference](#) and [Output Current Reference](#). That means, through the I²C, the main-buck can accept a target value change of these two reference sources while the [iEN](#) is logic=H.

See [Main-buck Power-Good](#).

Negative Transition with R_{DIS}

In the [Output Voltage Reference](#) is programmed for a lower target voltage from the current output, it may take long time period to reach to the new target value when very little load current / activities there. To accelerate such light-load negative transition, the device utilizes the [Output Discharge Resistor](#) block when the [Reg09\[5\]](#) bit is logic-H.

Main-buck EMI Tune-up

For the purpose of improving its EMI performance, this main-buck provides programmable switching node slew rate. By changing the [Reg0E\[3:2\]](#) bits, an application system designer can balance the tradeoff between its power conversion efficiency and its EMI noise level. By selecting slower transient rate, the noise performance improves; faster transient rate improves the efficiency. See [Table 28](#) for the available options.

Output Current Protections



In this datasheet, following three function names refer to clearly different meanings and behaviors of the device.

Programmable Current Limit

The [Programmable Current Limit function](#) is a regulation control of the main-buck output current at a programming target value ([CC](#): constant-current operation), within a safe operation area (SOA) of the device. This means a continuous operation at this programmable current limit is safe and supported.

Cycle-by-cycle Current Limit

The [Cycle-by-cycle Current Limit protection](#) is a hard limit of the main-buck output current. The threshold of this protection is beyond the design and safe operation area of the device. Repeated events of this protection will degrade or damage the device permanently.

Over-Current Protection

The [Over-Current Protection \(OCP\)](#) is a superset of the cycle-by-cycle current limit protection. The OCP is also beyond the design and safe operation area of the device and repeated OCP events will degrade or damage the device permanently.

Cycle-by-cycle Current Limit

The cycle-by-cycle current limit protection monitors current flow on the integrated high-side and low-side FET devices at every PWM cycle. When the high-side FET current flow exceeds the $I_{OCP(CBC,high)}$ threshold, the protection forces the

SW pin to the low state (high-side FET: OFF, low-side FET: ON) until the low-side FET current flow comes below the $I_{OCP(CBC,low)}$ target. During this protection working, the gate driver logic circuits ignore signals from main regulation control blocks.

A result of the cycle-by-cycle current limit protection looks like a CC operation. And also, continuous cycle-by-cycle operation reports the device in a CC operation by setting the [Reg03\[4\]](#) bit to logic-H.

Unlike the [Programmable Current Limit](#) operation, this cycle-by-cycle current limit protection is outside of the device safe operating area and the system should not operate the device in a continuous cycle-by-cycle current limit.

Over-Current Protection

The over-current protection is a superset of the [Cycle-by-cycle Current Limit](#) protection. When the [Cycle-by-cycle Current Limit](#) block repeats four (4) consecutive pairs of $I_{OCP(CBC,high)}$ and $I_{OCP(CBC,low)}$ detections, the device triggers this over-current protection.

The [Reg02\[6\]](#) bit is set logic-H to indicate this error.

See [Executing Protections](#) for the execution of this protection.

Practically, without any board level failure condition, the [Cycle-by-cycle Current Limit](#) protection reduces main inductor current flow very effectively within one cycle before observing four times of events. So this over-current protection gets triggered by an event of shorting the output, shorting the SW pin or shorting the coil.

Over-Voltage Protection

The over-voltage protection (OVP) monitors and maintains the output voltage at the FB_VO pin not to exceed the V_{OVP} threshold. For any reason, it exceeds the threshold, the main-buck triggers the over-voltage protection.

The [Reg02\[5\]](#) bit is set logic-H to indicate this error.

See [Executing Protections](#) for the execution of this protection.

Under-Voltage Protection

The under-voltage protection (UVP) monitors the output voltage at the FB_VO pin at the $V_{UVP(CV)}$ or the $V_{UVP(CC)}$ threshold. See [UVP selection](#). For any reason, it falls below the threshold, the device triggers the under-voltage protection.

The [Reg02\[4\]](#) bit is set logic-H to indicate this error.

See [Hiccup Operation](#), [Latch-off Operation](#) and [Executing Protections](#) for the execution of this protection.

UVP selection

To support various application cases, the main-buck provides different UVP threshold options.

When using the [CC](#) block, the output voltage is expected to drop when transits from the [CV](#) to the [CC](#) operation. So the UVP is expected to trigger at lower threshold target for the CC operation. The [Reg0B\[3\]](#) bit at logic-L selects $V_{UVP(CC)}$ for this purpose. Setting this bit at logic-H selects $V_{UVP(CV)}$ for the CV operation.

In case a wide CC operation range is needed more than the $V_{UVP(CC)}$ target, the UVP can be disabled by setting the [Reg09\[3\]](#) bit at logic-H. With this [Reg09\[3\]](#) bit, the [CC](#) block keeps its operation to the full range down to the $V_{IT(CC,fall)}$ target.



By setting the [Reg09\[3\]](#) bit, the UVP protection "action" is disabled at the [Control Logic](#) block level regardless of the FB_VO pin voltage. Still the status indicator bit [Reg02\[4\]](#) and its detector circuit is active and an interrupt is generated when the FB_VO cross the threshold. The [Reg07\[4\]](#) mask bit helps this situation if an interrupt is not needed.



By disabling the UVP by the [Reg09\[3\]](#) bit, there is no way to detect an event of output short. When a short event happens without the UVP, there are only the [Thermal Protection](#) and the [Over-Current Protection](#) blocks to protect the device and a risk of damaging the device increases.

Hiccup Operation

By setting the [Reg09\[2\]](#) bit at logic-L, the main-buck regulator repeats a "wait" and "retry" cycle, that is so called a "hiccup" operation. At the first time the output voltage hits the UVP threshold, the device disables its switching operation for the $t_{W(HICCUP)}$ of time period, and then the device restart the switching. If a cause of the under-voltage condition goes away

while disabled, the main buck regulator keeps working as normal; if the cause is still there, the device goes into another disabled state for another $t_{W(HICCUP)}$ period to repeat the hiccup operation.

See [Protection Level 4](#) for the execution of this protection.



When selecting the hiccup option, the device has no way to escape from an endless hiccup loop. A host controller device is expected to take a proper procedure to stop this endless hiccup loop.



When the device is in the hiccup operation, always there is a repeating narrow time window where the output voltage overshoots. This time windows are between almost-end of soft-start operation and a sudden event of releasing hiccup cause(s). During this time window, the device has almost finished a soft-start operation and the target reference voltage is high enough but the device does not judge next round of hiccup yet. So the device starts working at a very high duty cycle to overshoot.

The latch-off option is free from this overshoot concern.

Latch-off Operation

By setting the [Reg09\[2\]](#) bit at logic-H, the main-buck regulator latches the OFF status.

See [Protection Level 3](#) for the execution of this protection.

Executing Protections

The ACT41000 integrates multiple levels of device protections. Each level of protection behavior is explained in following sections in the order of severity.

Protection Level 1

The level 1 protection is a complete shutdown of the device except very minimum functions.

When following protections are triggered, the device stops its entire function except UVLO and OVLO blocks because the input voltage VIN (and PVIN) is out of acceptable operation range.

See [Recommended Operating Conditions](#).

- [Under-Voltage Lock-Out](#)
- [Over-Voltage Lock-Out](#)

This level 1 protection status continues until both UVLO and OVLO are released.

 The OVLO does not protect the device from any potential damage caused by over-voltage events. See [Note of Absolute Maximum Rating](#).

Protection Level 2

The level 2 protection is a whole device reset of the device by executing an auto-restart procedure.

When following protections are triggered, the device executes the [Reset Sequence](#) because the device cannot continue its normal operations safely.

- [Mini-buck Over-Current Protection](#)
- [Mini-buck Over-Voltage Protection](#)
- [Mini-buck Under-Voltage Protection](#)
- [AUX LDO Under-Voltage Protection](#)
- [Hard TSD](#)

Reset Sequence

1. Stop the [Mini-buck Regulator](#) and [Auxiliary LDO](#).
2. Start a logic timer of the $t_{D(RESET)}$ reset blanking period.
3. Restart the [Mini-buck Regulator](#) at the time out of "2." timer.

Protection Level 3

The level 3 protection is a latch-OFF of the [Main-buck Regulator](#) function.

When following protections are triggered, the device turns OFF the [Main-buck Regulator](#) and remains OFF until the [iEN](#) signal becomes logic-L. This latch-OFF status is just like a device waiting for an enable trigger even though [iEN](#) maintains logic-H from the timing of event caused this latch-OFF state.

- [Latch-off Operation](#)
- [SYNC Input Error Latch-off Operation](#)
- [Over-Voltage Protection](#)
- [Over-Current Protection](#)

Protection Level 4

The level 4 protection is a temporary disable of the [Main-buck Regulator](#) function, with an auto-restart. Or it is so called a "hiccup" operation.

When following protections are triggered, the device turns OFF the [Main-buck Regulator](#) for the $t_{W(HICCUP)}$ period and retry to activate the main-buck. When a cause of protection remains, another disable cycle is repeated for another $t_{W(HICCUP)}$ period.

- [Hiccup Operation](#)
- [SYNC Input Error Hiccup Operation](#)
- [Soft TSD](#)

Protection R_{FREQ}

In normal conditions, the R_{FREQ} Protection is a short-period transition state. Only when the device cannot validate R_{FREQ} value in the Recommended R_{FREQ} Range, due to a wrong PCB assembly, the device repeats this R_{FREQ} validation forever. This loop is a sort of dead-lock because the bias block is ready but cannot activate the main-buck due to the unreliable R_{FREQ} . By repeating this R_{FREQ} checking loop, the device ensures to keep sending an interrupt of the Reg01[4] bit. This protection is only performed before entering the Bias Ready state and it is not continuously monitoring <Rfreq> after passing the Bias Ready state.

I²C Registers

In this section, I²C register mappings and bit assignments are explained. Please refer to [I²C Interface](#) section how to access, how to setup these registers.

Register Address Map

This is an entire mapping of I²C registers on the ACT41000 device. Here are the meanings of each column in [Table 6](#).

Reg Addr	I²C register address number in hexadecimal
Reg Name	Register name
R/W	Read / Write type of register R : Read only W : Write only R/W : Read and Write
Def	Default value
F/P	Factory Programming support Y : The default values can be programmed by a production test. N : The default values are fixed / hard-coded.
Description	Description of the register



Please contact your local sales representatives for availabilities of different **Factory Programming** default settings. See [Factory Programming Options](#).

In [Table 6](#) below, each register address value string is a link to the detailed bit description.

Table 6. Register Address Map

Reg Addr	Reg Name	R/W	Def	F/P	Description
0x00	State-Machine	R	—	N	Current position of the state-machine
0x01	Interrupt #1	R	—	N	Interrupt byte #1
0x02	Interrupt #2	R	—	N	Interrupt byte #2
0x03	Status Flag	R	—	N	Status byte (no interrupt)
0x04	(Reserved)	R	—	N	(not in use)
0x05	Command	R/W	0x00	N	Command to trigger actions
0x06	Interrupt Mask #1	R/W	0x00	Y	Interrupt mask byte #1 for the register Reg01
0x07	Interrupt Mask #2	R/W	0x00	Y	Interrupt mask byte #2 for the register Reg02
0x08	Configuration byte #1	R/W	0x28	Y	Configure various device behaviors #1
0x09	Configuration byte #2	R/W	0xF3	Y	Configure various device behaviors #2
0x0A	DACOUT[10:3]	R/W	0x32	Y	DACOUT programming value bit 10 to 3
0x0B	DACOUT[2:0], Configuration byte #3	R/W	0x10	Y	DACOUT programming value bit 2 to 0 Configure various device behaviors #3
0x0C	ILIM Value	R/W	0xFF	Y	ILIM programming value bit 7 to 0
0x0D	AUX LDO Value	R/W	0x30	Y	VLDO programming value bit 5 to 0
0x0E	Configuration byte #4	R/W	0x23	Y	Configure various device behaviors #4
0x0F	Configuration byte #5	R/W	0x9E	Y	Configure various device behaviors #5

Register Bit Maps

Following sub-sections explain bit assignments of each I²C register. Here are the meanings of each column in below bit tables.

Bit #	Bit position (number)
Bit(s) Name	Bit(s) name
Def	Default value
Description	Description of the bit(s)

0x00 State-Machine

The register 0x00 is **Read Only** type. It indicates current position of the state-machine. See [Control Logic](#).

Table 7. Register 0x00

Bit #	Bit(s) Name	Def	Description
7		0	(un-used bit)
6		0	(un-used bit)
5		0	(un-used bit)
4		0	(un-used bit)
3	State[3]	0	See Table 8 .
2	State[2]	0	
1	State[1]	0	
0	State[0]	0	

Table 8. State-Machine Bits [3:0]

Value (bin)	Value (hex)	Position of State-Machine
0000	0x00	No Power, in Under-Voltage Lock-Out
0001	0x01	Bias Ramp , initialing mini-buck ^[1]
0010	0x02	Bias Reset
0011	0x03	Bias Ramp checking R _{ADDR} ^[1]
0100	0x04	Bias Ramp
0101	0x05	Bias Ready checking R _{FREQ} ^[1]
0110	0x06	R_{FREQ} Checking Loop ^[2]
0111	0x07	Bias Ready
1000	0x08	Main-buck Ramp enabling main-buck ^[1]
1001	0x09	Main-buck Ramp
1010	0x0A	Main-buck ON
1011	0x0B	Main-buck Shutdown
1100	0x0C	Main-buck Error

^[1] Short transit, not staying loner at this position

^[2] Not in the [Table 1](#), see [R_{FREQ} Checking Loop](#)

0x01: Interrupt #1

0x02: Interrupt #2

The registers 0x01 and 0x02 are **Read Only**. These 2 registers indicate cause(s) of the latest interrupt event by setting **1** at corresponding bit(s), so bit(s) of **0** mean nothing happened (normal). In the [Reg01](#) and [Reg02](#), trigger events setting **1** are described. See [Interrupt Output](#).

Bits in these registers will be automatically cleared by reading the value with an I²C command.

This automatic bit-clear action applies if the cause of an interrupt is resolved at the timing of a READ action. For most of the bits in 0x01 and 0x02, the automatic bit-clear happens because these protection events trigger shutdown actions to resolve the error situation.

Table 9. Register 0x01

Bit #	Bit(s) Name	Def	Description
7	Main-buck in CC/CV	0	Becomes 1 when the main-buck transits CC⇒CV or CV⇒CC. See CC / CV Interrupt/Monitor .
6		0	(un-used bit)
5	Out of Range, SYNC Input	0	Becomes 1 when the SYNC pin input clock is out of range. See Clock Synchronizer .
4	Out of Range, R _{FREQ}	0	Becomes 1 when the R _{FREQ} value, probed, is out of range. See R_{FREQ} Protection .
3	T _{SD(HARD)} Event	0	Becomes 1 when the T _J exceeds the T _{SD(HARD)} threshold. See Thermal Protection .
2	T _{SD(SOFT)} Event	0	Becomes 1 when the T _J exceeds the T _{SD(SOFT)} threshold. See Thermal Protection .
1		0	(un-used bit)
0	V _{IT(OVLO)} Event	0	Becomes 1 when the V _{PVIN} exceeds the V _{IT(OVLO)} threshold. See Over-Voltage Lock-Out .

Table 10. Register 0x02

Bit #	Bit(s) Name	Def	Description
7		0	(un-used bit)
6	Main-buck Over-current Event	0	Becomes 1 when the output current in Over-Current Protection .
5	V _{OV} P Event	0	Becomes 1 when the V _O exceeds the V _{OV} P threshold. See Over-Voltage Protection
4	V _{UV} P(CV) or V _{UV} P(CC) Event	0	Becomes 1 when the V _O falls below the V _{UV} P(CV) or V _{UV} P(CC) threshold. See Under-Voltage Protection .
3	AUX LDO Under-voltage	0	Becomes 1 when the V _{O(VLDO)} falls below the V _{UV} P(VLDO) threshold. See AUX LDO Under-Voltage Protection
2	I _{OC} P(V5V) Event	0	Becomes 1 when the output current of the mini-buck exceeds the I _{OC} P(V5V) threshold. See Mini-buck Over-Current Protection .
1	V _{OV} P(V5V) Event	0	Becomes 1 when the V _{O(V5V)} exceeds the V _{OV} P(V5V) threshold. See Mini-buck Over-Voltage Protection .
0	V _{UV} P(V5V) Event	0	Becomes 1 when the V _{O(V5V)} falls below the V _{UV} P(V5V) threshold. See Mini-buck Under-Voltage Protection .

0x03: Status Flag

The register 0x03 is **Read Only** type. It indicates various status flags from internal circuit blocks.

Table 11. Register 0x03

Bit #	Bit(s) Name	Def	Description
7	WDT High	0	1*: Clock input at SYNC is too high/low to accept. 0: (normal), See SYNC Input Watch Dog Timer .
6	WDT Low	0	
5	Mini-buck in 100%	0	1*: Mini-buck is operating in 100% mode. 0: Mini-buck is operating out of 100% mode. See Mini-buck 100% Duty Operation .
4	Main-buck in CC	0	1*: Main-buck is operating in CC mode. 0: Main-buck is operating in CV mode. See Programmable Current Limit .
3	Main-buck in 100%	0	1*: Main-buck is operating in 100% mode. 0: Main-buck is operating out of 100% mode. See 100% Duty Operation .
2	PG of Main-buck	0	1*: Main-buck in "Power-good" condition 0: Main-buck in NOT "Power-good" condition See Main-buck Power-Good .
1		0	(un-used bit)
0		0	(un-used bit)

0x04: (Reserved)

The register 0x04 is reserved for future spins. Nothing is assigned to this register.

0x05: Command

The register 0x05 is **Read / Write** type. A writing action to this register triggers a certain action at the device.

Table 12. Register 0x05

Bit #	Bit(s) Name	Def	Description
7		0	(un-used bit)
6		0	(un-used bit)
5		0	(un-used bit)
4		0	(un-used bit)
3		0	(un-used bit)
2		0	(un-used bit)
1	Load DACOUT	0	Setting 1 to load DACOUT value in effect. Always reads 0. See Loading New DACOUT Value .
0	Enable Main-buck	0	Writing 1 to enable Main-buck See Main-buck Enable Control

0x06: Interrupt Mask #1

0x07: Interrupt Mask #2

The registers 0x06 and 0x07 are **Read / Write** type. These 2 registers are corresponding to the [Reg01](#) and [Reg02](#) respectively. Any 1 bit in Reg06 and Reg07 prevents (masks) an interrupt event triggered by the corresponding bit in Reg01

and Reg02. For example, Setting the [Reg07\[5\]](#) bit makes no interrupt event even though an over-voltage happened at the [Reg02\[5\]](#) bit. See [Interrupt Output](#).



When the [Reg08\[5\]](#) "Mask All" bit is 1, all [Reg06](#) and [Reg07](#) bits are overridden to 1 internally regardless of register values there.

Table 13. Register 0x06

Bit #	Bit(s) Name	Def	Description
7	Mask Main-buck in CC/CV	0	1: mask bit 7 of Reg01 0: (no-mask)
6		0	(un-used bit)
5	Mask Out of Range, SYNC Input	0	1: mask bit 5 of Reg01 0: (no-mask)
4	Mask Out of Range, R _{FREQ}	0	1: mask bit 4 of Reg01 0: (no-mask)
3	Mask T _{SD(HARD)} Event	0	1: mask bit 3 of Reg01 0: (no-mask)
2	Mask T _{SD(SOFT)} Event	0	1: mask bit 2 of Reg01 0: (no-mask)
1		0	(un-used bit)
0	Mask V _{IT(OVLO)} Event	0	1: mask bit 0 of Reg01 0: (no-mask)

Table 14. Register 0x07

Bit #	Bit(s) Name	Def	Description
7		0	(un-used bit)
6	Mask Main-buck Over-current Event	0	1: mask bit 6 of Reg02 0: (no-mask)
5	Mask V _{OVP} Event	0	1: mask bit 5 of Reg02 0: (no-mask)
4	Mask V _{UVP(CV)} or V _{UVP(CC)} Event	0	1: mask bit 4 of Reg02 0: (no-mask)
3	Mask AUX LDO Under-voltage	0	1: mask bit 3 of Reg02 0: (no-mask)
2	Mask I _{OCV(V5V)} Event	0	1: mask bit 2 of Reg02 0: (no-mask)
1	Mask V _{OVP(V5V)} Event	0	1: mask bit 1 of Reg02 0: (no-mask)
0	Mask V _{UVP(V5V)} Event	0	1: mask bit 0 of Reg02 0: (no-mask)

0x08: Configuration byte #1

The register 0x08 is **Read / Write** type. It configures the device behaviors as described.

Table 15. Register 0x08

Bit #	Bit(s) Name	Def	Description
7	PG Delay[1]	0	See Table 16 . See Main-buck Power-Good .
6	PG Delay[0]	0	
5	Mask All	1	1: overrides all Reg06 and Reg07 bits 1 internally . 0: "masking" follows each bit of Reg06 and Reg07 .
4	PGBIAS Delay[1]	0	See Table 17 and See PGBIAS Indicator Output .
3	PGBIAS Delay[0]	1	
2		0	(un-used bit)
1		0	(un-used bit)
0		0	(un-used bit)

Table 16. PG Delay [1:0]

Value (bin)	Value (hex)	PG pin Delay Time
00	0x00	0 ms (default)
01	0x01	0.25 ms
10	0x02	1 ms
11	0x03	4 ms

Table 17. PGBIAS Delay [1:0]

Value (bin)	Value (hex)	PGBIAS pin Delay Time
00	0x00	1 ms
01	0x01	1.25 ms (default)
10	0x02	1.5 ms
11	0x03	3 ms

0x09: Configuration byte #2

The register 0x09 is **Read / Write** type. It configures the device behaviors as described.

Table 18. Register 0x09

Bit #	Bit(s) Name	Def	Description
7	Servo Clock[1]	1	See Table 19 .
6	Servo Clock[0]	1	
5	Discharge in Servo	1	1: Use discharge resistor to drive V_O servo down. 0: Not use discharge resistor in servo. See Negative Transition with R_{DIS} and Output Discharge Resistor .
4	Discharge at OFF	1	1: Use discharge resistor when main-buck disabled. 0: Not use discharge resistor when main-buck disabled. See Main-buck Enable Control and Output Discharge Resistor .
3	Main-buck No UVP	0	1: disable main-buck under-voltage protection. 0: use main-buck under-voltage protection. See UVP selection .
2	Hiccup / Latch-off	0	1: Latch-off action in main-buck. 0: Hiccup action in main-buck. See Under-Voltage Hiccup and Under-Voltage Latch-off . Also, see SYNC Error Hiccup and SYNC Error Latch-off .
1	Enable Mini-buck	1	1: enable Mini-buck, automatically start-up Mini-buck. 0: disable Mini-buck, manually start-up Mini-buck. See V5V , External 5V Supply .
0	Enable AUX LDO	1	1: enable AUX LDO, automatically start-up AUX LDO. 0: disable AUX LDO, manually start-up AUX LDO. See AUX LDO Enable .

Table 19. Servo Clock [1:0]

Value (bin)	Value (hex)	Servo Clock Period
00	0x00	$t_{W(SERVO)} \times 1$
01	0x01	$t_{W(SERVO)} \times 2$
10	0x02	$t_{W(SERVO)} \times 4$
11	0x03	$t_{W(SERVO)} \times 8$ (default)

0x0A: DACOUT Value [10:3]

The register 0x0A is **Read / Write** type. It programs DACOUT value.

Table 20. Register 0x0A

Bit #	Bit(s) Name	Def	Description
7	DACOUT[10]	0	See Table 21. 3 more bits in Reg0B. See Output Voltage Reference.
6	DACOUT[9]	0	
5	DACOUT[8]	1	
4	DACOUT[7]	1	
3	DACOUT[6]	0	
2	DACOUT[5]	0	
1	DACOUT[4]	1	
0	DACOUT[3]	0	

Table 21. DACOUT[10:0]

Value (bin)	Value (hex)	DACOUT Voltage (mV)	V _O Voltage (V)
000 0000 0000	0x000	0.0	0.0000
...			
000 1110 1111	0x0EF	373.4	2.9875
000 1111 0000	0x0F0	375.0 ^[1]	3.0000
000 1111 0001	0x0F1	376.6	3.0125
...			
001 0000 1000	0x108	412.5	3.3
...			
001 1001 0000	0x190	625.0 (default)	5
...			
010 1101 0000	0x2D0	1125.0	9
...			
011 1100 0000	0x3C0	1500.0	12
...			
100 1011 0000	0x480	1875.0	15
...			
111 0111 1111	0x77F	2998.4	23.9875
111 1000 0000	0x780	3000.0 ^[2]	24.0000
111 1000 0001	0x781	3000.0	24.0000
...			
111 1111 1111	0x7FF	3000.0	24.0000

^[1] Minimum value of the DACOUT range characterized.

^[2] Maximum value of the DACOUT range characterized.

0x0B: Configuration byte #3, DACOUT[2:0]

The register 0x0B is **Read / Write** type. It configures the device behaviors as described.

Table 22. Register 0x0B

Bit #	Bit(s) Name	Def	Description
7	Enable main-buck 100%	0	1: enable main-buck 100% mode. 0: disable main-buck 100% mode. See 100% Duty Operation .
6	Enable main-buck Spread-Spectrum	0	1: enable main-buck spread-spectrum operation. 0: disable main-buck spread-spectrum operation. See Spread-spectrum Operation .
5		0	(un-used bit)
4	Enable main-buck CC	1	1: enable main-buck Constant-current operation. 0: disable main-buck Constant-current operation. See Programmable Current Limit .
3	Select main-buck UVP	0	1: select $V_{UVP(CV)}$. 0: select $V_{UVP(CC)}$. See UVP selection .
2	DACOUT[2]	0	See Table 21 .
1	DACOUT[1]	0	8 more bits in Reg0A .
0	DACOUT[0]	0	See Output Voltage Reference .

0x0C: ILIM Value

The register 0x0C is **Read / Write** type. It programs ILIM value.

Table 23. Register 0x0C

Bit #	Bit(s) Name	Def	Description
7	ILIM[7]	1	See Table 24. See Output Current Reference.
6	ILIM[6]	1	
5	ILIM[5]	1	
4	ILIM[4]	1	
3	ILIM[3]	1	
2	ILIM[2]	1	
1	ILIM[1]	1	
0	ILIM[0]	1	

Table 24. ILIM[7:0]

Value (bin)	Value (hex)	I _{LIM} Current (μA)	Output Current (mA) with R _{CS} =20 mΩ and R _{ILIM} =16 kΩ
0000 0000	0x00	0.39	15.6
0000 0001	0x01	0.78	31.3
0000 0010	0x02	1.17	46.9
...			
1111 1101	0xFD	99.2	3969
1111 1110	0xFE	99.6	3984
1111 1111	0xFF	100.0 (default) (= I _{LIM(100)})	4000

0x0D: AUX LDO Value

The register 0x0D is **Read / Write** type. It programs AUX LDO value.

Table 25. Register 0x0D

Bit #	Bit(s) Name	Def	Description
7		0	(un-used bit)
6		0	(un-used bit)
5	LDO Voltage[5]	1	See Table 26 . See AUX LDO Output Voltage Programming .
4	LDO Voltage[4]	1	
3	LDO Voltage[3]	0	
2	LDO Voltage[2]	0	
1	LDO Voltage[1]	0	
0	LDO Voltage[0]	0	

Table 26. LDO Voltage[5:0]

Value (bin)	Value (hex)	V _{O(VLDO)} Voltage (V)
00 0000	0x00	0.90
00 0001	0x01	0.95
00 0010	0x02	1.00
00 0011	0x03	1.05
...		
00 0110	0x06	1.20
...		
00 1100	0x0C	1.50
...		
01 0010	0x12	1.80
...		
10 0000	0x20	2.50
...		
10 1010	0x2A	3.00
...		
11 0000	0x30	3.30 (default)
...		
11 1101	0x3D	3.95
11 1110	0x3E	4.00
11 1111	0x3F	4.05

0x0E: Configuration byte #4

The register 0x0E is **Read / Write** type. It configures the device behaviors as described.

Table 27. Register 0x0E

Bit #	Bit(s) Name	Def	Description
7		0	(un-used bit)
6		0	(un-used bit)
5	(fixed value)	1	always program this bit to 1 .
4		0	(un-used bit)
3	Main-buck HSD[1]	0	See Table 28 .
2	Main-buck HSD[0]	0	See Main-buck EMI Tune-up .
1	(fixed value)	1	always program this bit to 1 .
0	(fixed value)	1	always program this bit to 1 .

Table 28. Main-buck Gate Driver Strength[1:0]

HSD[1]	HSD[0]	SW node Rising/ Falling Time (ns)	SW node Falling Time (ns)
0	0	10.6 (default)	5.1 (default)
0	1	6.0	4.7
1	0	5.5	4.2
1	1	5.0	3.8

0x0F: Configuration byte #5

The register 0x0F is **Read / Write** type. It configures the device behaviors as described.

Table 29. Register 0x0F

Bit #	Bit(s) Name	Def	Description
7	Enable Mini-buck 100%	1	1: enable Mini-buck 100% mode. 0: disable Mini-buck 100% mode. See Mini-buck 100% Duty Operation .
6	Enable Mini-buck Spread-Spectrum	0	1: enable Mini-buck spread-spectrum operation. 0: disable Mini-buck spread-spectrum operation. See Mini-buck Spread-spectrum Operation .
5	Enable Mini-buck Forced CCM	0	1: enable Mini-buck Forced CCM operation. 0: disable Mini-buck Forced CCM (= pulse-skipping) operation. See Mini-buck Forced Continuous Conduction Operation .
4	Mini-buck HSD[1]	1	See Table 30 . See Mini-buck EMI Tune-up .
3	Mini-buck HSD[0]	1	
2	Mini-buck LSD[1]	1	See Table 31 . See Mini-buck EMI Tune-up .
1	Mini-buck LSD[0]	1	
0		0	(un-used bit)

Table 30. Mini-buck High-side-driver Strength[1:0]

HSD[1]	HSD[0]	SW5V node Rising Speed
0	0	Better EMI (low noise)
0	1	(not valid, don't choose)
1	0	(not valid, don't choose)
1	1	Better Efficiency (default)

Table 31. Mini-buck Low-side-driver Strength[1:0]

LSD[1]	LSD[0]	SW5V node Falling Speed
0	0	Better EMI
0	1	(not valid, don't choose)
1	0	(not valid, don't choose)
1	1	Better Efficiency (default)

Application Information

RF Power Amplifier I_{DQ} Detection and Bias Sequence

Without using an additional current sensing amplifier, the ACT41000 supports precise drain bias current (I_{DQ}) detection of an RF power amplifiers, by using the integrated **Programmable Current Limit** function.

As an example, the Qorvo[®] QPA2211 device is selected to illustrate how the ACT41000 detects the I_{DQ} . See the [Figure 1](#).

The Original QPA2211 Datasheet Bias Sequence

Bias Up Procedure

1. Set I_D limit to 3500 mA, I_G limit to 40mA
2. Apply -5 V to V_G
3. Apply 22 V to V_D ; ensure I_{DQ} is approx. 0 mA
4. Adjust V_G until $I_{DQ} = 280$ mA
5. Turn on RF supply

Bias Down Procedure

1. Turn off RF supply
2. Reduce V_G to -5 V; ensure I_{DQ} is approx. 0 mA
3. Set V_D to 0 V
4. Turn off V_D supply
5. Turn off V_G supply

The QPA2211 Bias Sequence with ACT41000

Bias Up Procedure

1. @MCU & Gate Driver
Set I_G limit to 40mA
2. @ACT41000
Set **current limit** at 280 mA ^[1]
3. @MCU & Gate Driver
Apply -5 V to V_G
4. @ACT41000
Turn on V_D ^[2]
5. @MCU & Gate Driver
Start sweeping up V_G
6. @MCU & Gate Driver
Stop sweeping V_G upon an interrupt from the PGBIAS pin of ACT41000
7. @ACT41000
Set **current limit** at 3500 mA ^[3]
8. Turn on RF supply

Bias Down Procedure

1. Turn off RF supply
2. @ACT41000
Set **current limit** at 280 mA
3. @MCU & Gate Driver
Reduce V_G to -5 V
4. @ACT41000
Set **voltage reference** at the minimum ^[4]
5. @ACT41000
Turn off V_D ^[2]
6. @MCU & Gate Driver
Turn off V_G supply

^[1] ^[3] See 0x0C register and Programmable Current Limit

^[2] See 0x05 register and Main-buck Enable Control

^[4] See 0x05 register, 0x0A register, 0x0B register and Output Voltage Reference

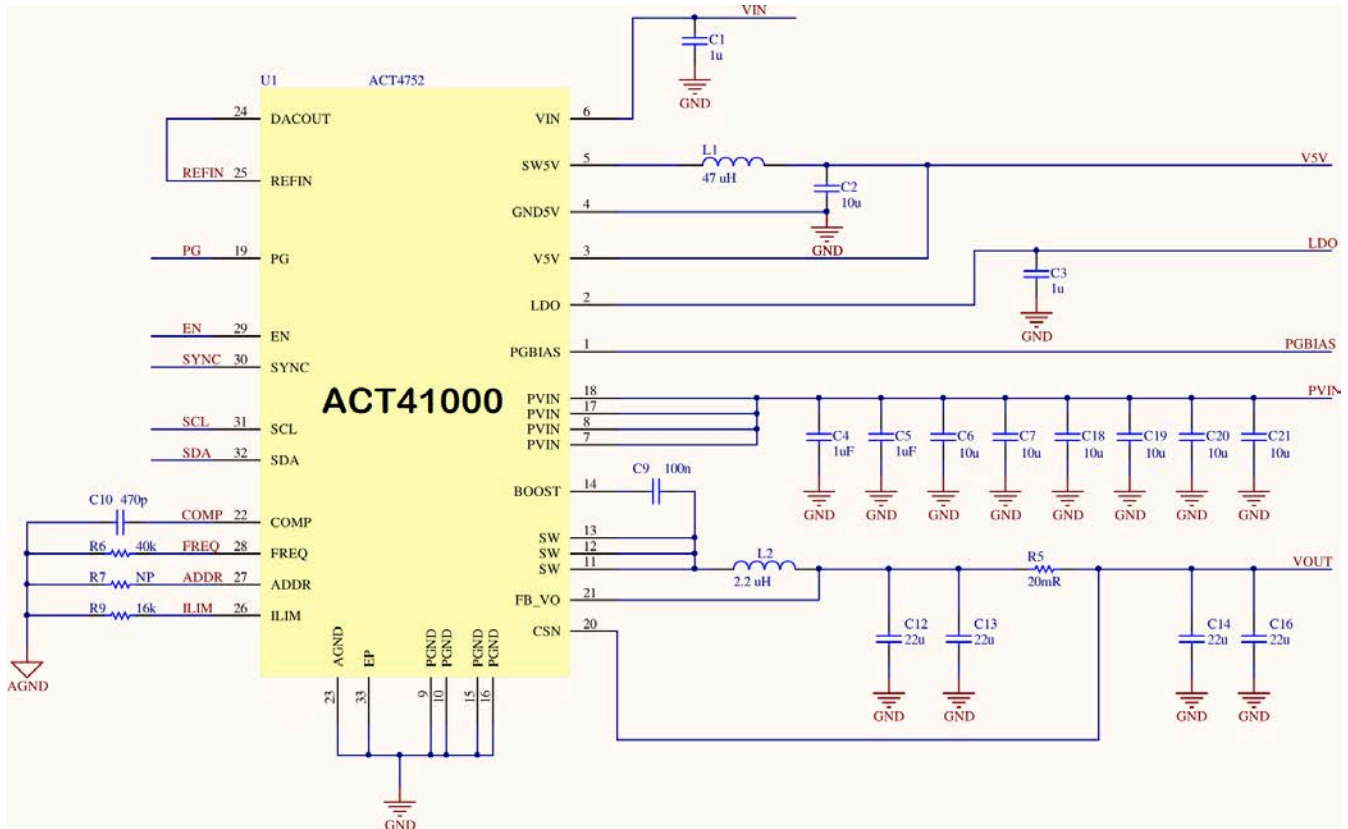

Figure 62. Example Schematic: DC-DC Voltage Regulator Industrial-type Application

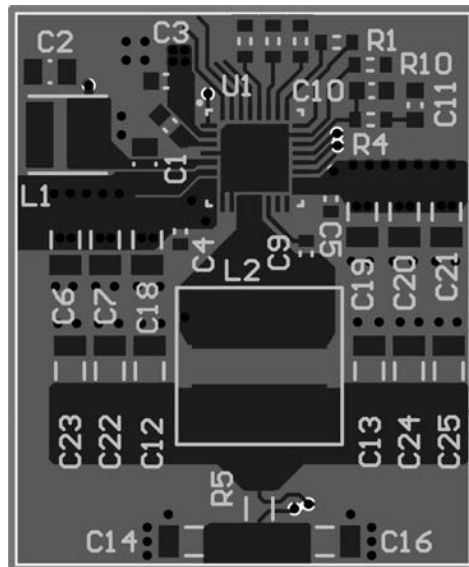

Figure 63. PCB Layout Example

Component Selection

Mini-buck Components

Mini-buck Input Capacitors

Between the VIN pin and the GND5V pin, a good quality, at least, 1 µF of capacitor is required. Please this capacitor as close as the device.

Mini-buck LC Output Filter

The mini-buck is not designed to support excessive amount of output capacitance. Large amount of output capacitor(s) may cause failures, like over (in-rush) current. Strongly recommended to follow this design guideline.

The **Mini-buck Regulator** outputs 5 V self-biasing power at the V5V node. An LC output filter is needed between the SW5V pin and the GND5V pin.

An inductor value of the LC output filter is 47 μH .

(At least) two pieces of output capacitors are recommended. The first high frequency capacitor must be connected very close to the device with the highest priority of all components. The target value of the high frequency capacitor is 0.1 μF . The second main capacitor is recommended to be 10 μF .

AUX LDO Components

AUX LDO Output Capacitors

The **Auxiliary LDO** needs a good quality output capacitor between the VLDO pin and the ground. This capacitor is recommended to be 1 μF .

Main-buck Components

Main-buck Input Capacitors

The **Main-buck Regulator** has multiple of its power input pins PVIN at 2 edges of the device package. Good quality MLCC input capacitors should be connected between the PVIN and the PGND pins, **at both edges of the package**. Depending on ripple current amplitude and input ripple voltage amplitude, a couple of bulk capacitors may be used in parallel with the good quality MLCC. These bulk capacitors are not necessary to be placed at both edges of the package.

Main-buck LC Output Filter

The main-buck is not designed to support excessive or insufficient amount of LC product. Strongly recommended to follow this design guideline.

When in 100% mode operation, the main-buck operates down to one eighth of switching frequency and it requires bigger output capacitance. Strongly recommended to follow this design guideline.

The **Main-buck Regulator** is a topology of step-down (buck) switching regulator and it requires an LC output filter between the SW node to the ground. This LC filter is a part of control stability design components, it must stay in a certain value range. The **Table 32** shows a center target value set of the LC filter.

Table 32. Main-buck LC filter

Switching Frequency	Output Voltage Range	L1	C _{OUT}	LC Resonant Frequency
450 kHz	below 12 V	4.7 μH	22 μF x 5	7 kHz
	3 V to 24 V	6.8 μH	22 μF x 5	5.8 kHz
1050 kHz	below 20 V	3.3 μH	22 μF x 4	9.3 kHz
	3 V to 24 V	4.7 μH	22 μF x 4	7.8 kHz
1650 kHz	3 V to 24 V	3.3 μH	22 μF x 4	10.3 kHz
2.25 MHz	3 V to 24 V	2.2 μH	22 μF x 4	11.4 kHz

Main-buck Bootstrap Capacitor

The **Main-buck Regulator** integrates N-type FET as its high-side switching device. To maintain a gate drive power supply to the high-side N-type FET, a good quality MLCC should be connected between the BOOST pin and the SW pins. The recommended value of this bootstrap capacitor is 0.1 μF .

Main-buck Compensation Network

The Main-buck Regulator requires a compensation capacitor between the COMP pin and the AGND pin as shown in Figure 64.

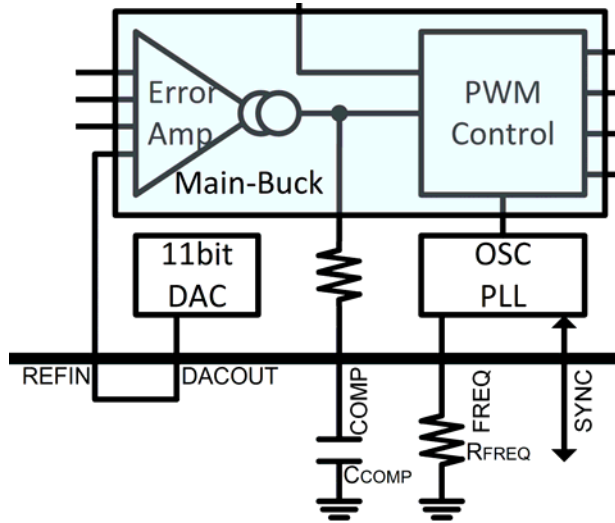

Figure 64. Main-buck Compensation Capacitor

For entire frequency range, use 470 pF capacitor as shown in the Table 33.

Table 33. Main-buck Compensation Capacitor

Switching Frequency	C _{COMP} (pF)
450 kHz	470
1050 kHz	470
1650 kHz	470
2.25 MHz	470

Other Components

R_{FREQ} Resistance

See Switching Frequency Selector.

R_{LIM} Resistance

See Output Current Reference.

SCL/SDA Pull-up Resistance

See I²C Interface.

PGBIAS/PG Pull-up Resistance

The PGBIAS and PG pins are designed to drive maximum 1 mA of sink current from the open-drain transistors. A pull-up resistor at the PGBIAS or the PG pin is required to limit the current into these pins below 1 mA. See PGBIAS Indicator Output and Main-buck Power-Good.

The lower end of recommended pull-up resistors range is determined by the current into these pins. In many applications, 0.1 mA of current, that is one tenth of the maximum 1 mA, is more than enough. It is a simple Ohm's law and the recommended minimum pull-up resistor is calculated as in Eq.(12).

Note that a pull-up voltage source is an application system dependent.

$$R_{MIN(PG,PGBIAS)} = \frac{V_{PULL-UP}}{0.1(mA)} \tag{12}$$

The higher end of recommended pull-up resistors range is determined by the noise immunity. In many applications, as a rule of thumb, a current more than 5 μA is robust enough staying away from noise issues. From here, it is a simple Ohm's law and the recommended maximum pull-up resistor is calculated as in Eq.(13). Note that a pull-up voltage source is an application system dependent.

$$R_{\text{MAX(PG,PGBIAS)}} = \frac{V_{\text{PULL-UP}}}{5(\mu\text{A})} \tag{13}$$

Timing Control between PGBIAS and EN

By using an RC delay circuit from the PGBIAS output to the EN pin, the device can be programmed to meet application specific timing needs. And, also, a proper delay timing circuit can mask only interrupt signal portion of output from the PGBIAS pin.

The Figure 65 is an example of a delay circuit configuration to meet following requirements.

- The EN pin receives only "power-good" signal, an interrupt signal filtered.
- The PGBIAS pin maintains both "power-good" and "interrupt" signals.

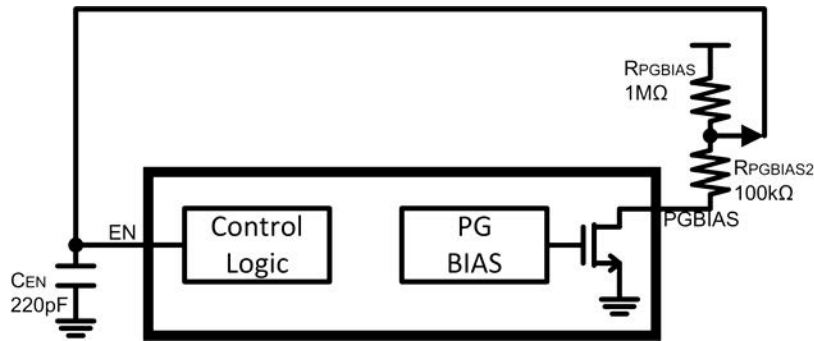

Figure 65. Example PGBIAS drives EN with an RC filter

Application Examples

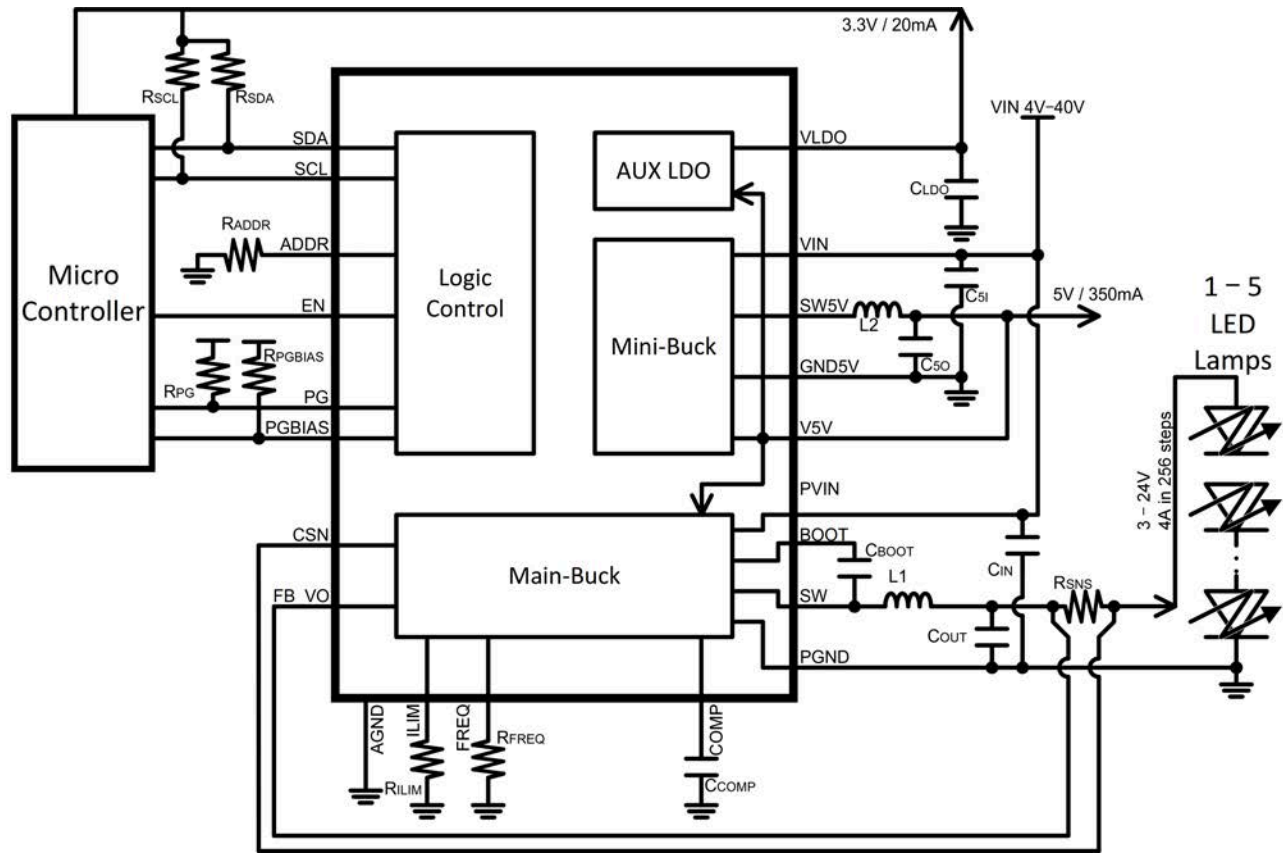

Figure 66. Example Diagram: High Brightness LED Driver

Factory Programming Options

At a production test before shipping, the ACT41000 device can have different behavior(s) from the descriptions in this datasheet by burning different configuration ROM bits.

In this section, there's a quick summary of possible configuration options.



Please contact your local sales representatives for an availability of such options and a minimum purchase quantity may apply.

- Main-buck in 0.75 V to 6 V output
- Many of I²C register default values
- AUX LDO default value
- Main-buck in a constant-ON (COT) control, instead of current-mode control
- Stronger spread-spectrum for both mini-buck and main-buck
- Different soft-start time of mini-buck
- Lower PG threshold for the V5V pin
- Alternative mini-buck control without using an external inductor

Package Outline and Dimensions

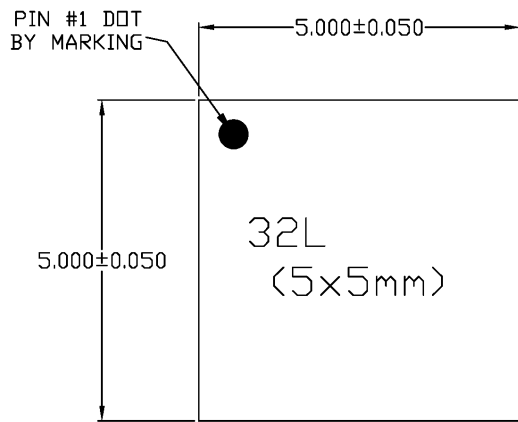

TOP VIEW

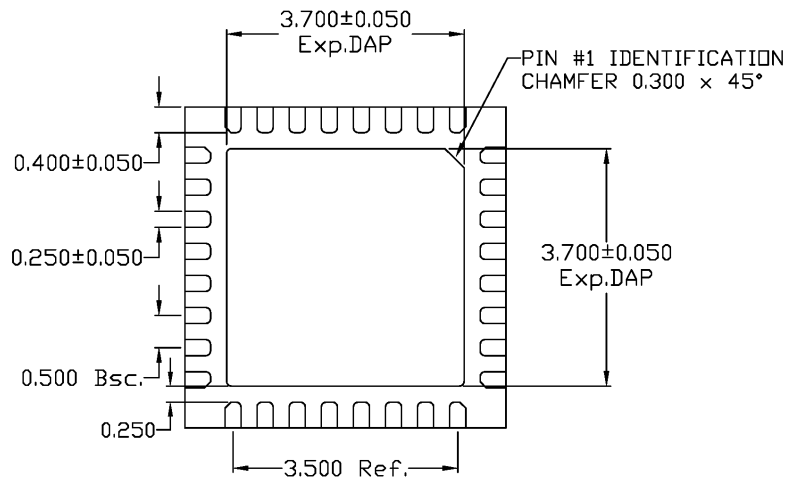

BOTTOM VIEW

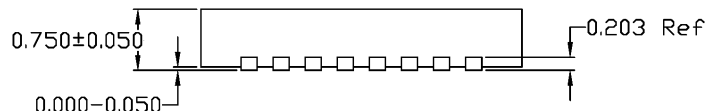

SIDE VIEW

Figure 67. 32-pin QFN, 5 mm × 5 mm, 0.5 mm pitch

Handling Precautions

Parameter	Rating	Standard
ESD — Human Body Model (HBM)	Class 2	ANSI/ESDA/JEDEC JS-001-2017
ESD — Charged Device Model (CDM)	Class C3	ANSI/ESDA/JEDEC JS-002-2014
MSL — Moisture Sensitivity Level	Level 3	IPC/JEDEC J-STD-020



Caution!
ESD-Sensitive Device

Solderability

Compatible with both lead-free (260 °C max. reflow temperature) and tin/lead (245 °C max. reflow temperature) soldering processes.

REVISION HISTORY

Rev	Date	Orderable Part Number Affected	Description
Rev.A	Apr 15, 2021	ACT41000-101	Initial release