



ACT4529M

40 V/3.0 A CV/CC Buck Converter Featuring QC2.0, USB Auto-Detect and USB-PD

FEATURES

- AEC-Q100 Automotive Qualified
- -40 °C ~ 125 °C Junction Temperature Range Automotive Qualified
- Passes SAE J1752 M8A EMC testing
- Quick Charge™ 2.0 Certified by Qualcomm® and UL.
 - UL Certificate No. 4787083099-1
 - <https://www.qualcomm.com/documents/quick-charge-device-list>
- 40 V Input Voltage Surge
- 4.5 V - 36 V Operational Input Voltage
- 5.1 V/9.1 V/12.1 V Output with +/-1% Accuracy
- Up to 3.0 A Output current
- Constant Current Regulation Limit
- QC2.0 + Auto-Detect + USB-PD Type-C Support
- Hiccup Mode Protection at Output Short
- >90% Efficiency at Full Load
- 0.5 mA Low Standby Input Current
- 5.7 V/10.1 V/13.5 V Output Over-voltage Protection for 5.1 V/9.1 V/12.1 V Outputs
- Cord Voltage Compensation
- Meet EN55022 Class B Radiated EMI Standard
- 8 kV ESD HBM Protection on DP and DM
- SOP-8EP Package

APPLICATIONS

- Automotive Applications
- Car Charger
- Cigarette Lighter Adaptor (CLA)
- CV/CC regulation DC/DC converter

GENERAL DESCRIPTION

ACT4529 is a wide input voltage, high efficiency step-down DC/DC converter that operates in either CV (Constant Output Voltage) mode or CC (Constant Output Current) mode. This device has QC2.0 built in to provide 5.1 V/9.1 V/12.1 V outputs as requested by attached portable devices. Besides building in QC2.0 decoding, it also supports Apple, Samsung and BC1.2 devices to charge at full current rate. ACT4529 has an interface for USB-PD control via a tri-state digital pin. V_{OUT} is 5.1 V if this pin is floating, V_{OUT} is 9.1V when this pin voltage is less than 0.8 V and V_{OUT} is 12.1 V while this pin voltage is more than 2.0 V.

ACT4529 has accurate output current limits under constant current regulation. It provides up to 3.0 A output current at 125 kHz switching frequency. ACT4529 utilizes adaptive drive technique to achieve good EMI performance while main >90% efficiency at full load for mini size CLA designs. It also has output short circuit protection with hiccup mode. The average output current is reduced to below 6 mA when output is shorted to ground. Other features include output over voltage protection and thermal shutdown.

This device is available in a SOP-8EP package and requires very few external components for operation.

For details on SAE J1752 M8A EMC performance and testing, refer to Active-Semi application note AN-106, ACT4529M Automotive EMC Performance.

Typical Application Circuit

V/I Profile

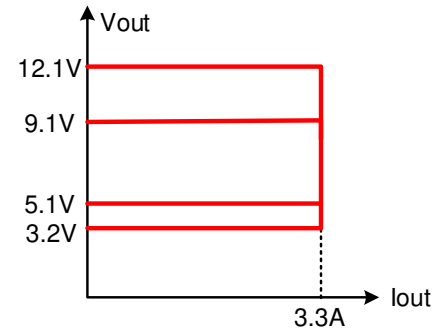
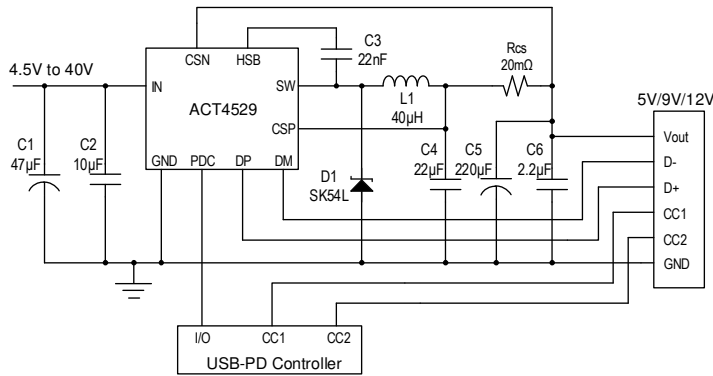

ORDERING INFORMATION

PART NUMBER	PDC	USB AUTO DETECT	QC2.0	CERTIFICATION	PACKAGE
ACT4529MYH-T0010	Yes	No	Yes	QC 2.0	SOP-8EP
ACT4529MYH-T1011	Yes	Yes	Yes	N/A	SOP-8EP

PIN CONFIGURATION

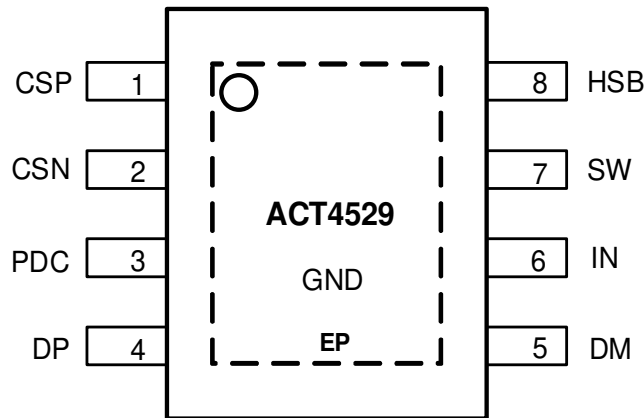

SOP-8EP

Top View

PIN DESCRIPTIONS

PIN	NAME	DESCRIPTION
1	CSP	Voltage Feedback Input. Connect to node of the inductor and output capacitor. CSP and CSN Kelvin sense is recommended.
2	CSN	Negative input terminal of output current sense. Connect to the negative terminal of current sense resistor.
3	PDC	USB-PD Control Pin. floating: 5.1 V, pulled high: 12.1 V, pulled low: 9.1 V. Do not drive this pin higher than 5 V.
4	DP	Data Line Positive Input. Connected to D+ of attached portable device data line. This pin passes 8 kV HBM ESD.
5	DM	Data Line Negative Input. Connected to D- of attached portable device data line. This pin passes 8 kV HBM ESD.
6	IN	Power Supply Input. Bypass this pin with a 10 μ F ceramic capacitor to GND, placed as close to the IC as possible.
7	SW	Power Switching Output to External Inductor.
8	HSB	High Side Bias Pin. This provides power to the internal high-side MOSFET gate driver. Connect a 22 nF capacitor from HSB pin to SW pin.
9	GND	Ground and Heat Dissipation Pad. Connect this exposed pad to large ground copper area with copper and vias.

ABSOLUTE MAXIMUM RATINGS

PARAMETER	VALUE	UNIT
IN to GND	-0.3 to 40	V
SW to GND	-1 to $V_{IN} + 1$	V
HSB to GND	$V_{SW} - 0.3$ to $V_{SW} + 7$	V
CSP, CSN to GND	-0.3 to +15	V
PDC to GND	-0.3 to +6	V
All other pins to GND	-0.3 to +6	V
Junction to Ambient Thermal Resistance	46	$^{\circ}$ C/W
Operating Junction Temperature	-40 to 150	$^{\circ}$ C
Storage Junction Temperature	-55 to 150	$^{\circ}$ C
Lead Temperature (Soldering 10 sec.)	300	$^{\circ}$ C

ⓘ: Do not exceed these limits to prevent damage to the device. Exposure to absolute maximum rating conditions for long periods may affect device reliability

ELECTRICAL CHARACTERISTICS

($V_{IN} = 12\text{ V}$, $T_J = -40\text{ °C} \sim 125\text{ °C}$, unless otherwise specified.)

PARAMETER	SYMBOL	CONDITION	MIN	TYP	MAX	UNITS
Input Over Voltage Protection	V_{IN_OVP}	Rising	40	42	44	V
Input Over Voltage Hysteresis				4		V
Input Over Voltage Response Time	$T_{V_{IN_OVP}}$	V_{IN} step from 30 V to 45 V		250		ns
Input Under Voltage Lockout (UVLO)	V_{IN}	Rising	4.15	4.5	4.75	V
Input UVLO Hysteresis				200		mV
Input Voltage Power Good Deglitch Time		No OVP		40		Ms
Input Voltage Power Good Deglitch Time		No UVP		10		us
Input Standby Current		$V_{IN} = 12\text{ V}$, $V_{OUT} = 5.1\text{ V}$, $I_{LOAD} = 0$		500		uA
Output Voltage Regulation	CSP	At Full Temperature	4.92 8.78 11.67	5.1 9.1 12.1	5.28 9.42 12.53	V
Output Voltage Regulation	CSP	At Room Temperature	5.05 9.0 11.95	5.1 9.1 12.1	5.15 9.2 12.25	V
Output Over Voltage Protection (OVP)		Output rising	5.5 9.7 13.0	5.7 10.1 13.5	6.0 10.5 14.0	V
Input Brownout Protection (ACT4529MYH-T1011 only)	V_{IN} Drop Threshold	Falling Threshold	7.5	8.0	8.5	V
		Hysteresis		200		mV
		V_{OUT} Drop Delay Time	416		480	ms
	QC and PDC	Restart time	416		480	ms
Output Over Voltage Deglitch Time				1.0		us
Output Voltage Cord Compensation	ACT4529MYH-T0010	66 mV between CSP and CSN	-25%	200	+25%	mV
	ACT4529MYH-T1011		-25%	200	+25%	mV
Output Under Voltage Protection (UVP)	V_{OUT}	V_{OUT} falling	-10%	3.2	10%	V
UVP Hysteresis	V_{OUT}	V_{OUT} rising		0.55		V
UVP Deglitch Time	V_{OUT}			10		us
UVP Blanking Time at Startup				3.5		ms

ELECTRICAL CHARACTERISTICS

($V_{IN} = 12\text{ V}$, $T_J = -40\text{ }^\circ\text{C} \sim 125\text{ }^\circ\text{C}$, unless otherwise specified.)

PARAMETER	SYMBOL	CONDITION	MIN	TYP	MAX	UNITS
Output Constant Current Limit		$R_{CS} = 20\text{ m}\Omega$	2.95	3.3	3.63	A
Hiccup Waiting Time				4.13		S
Top FET Cycle by Cycle Current Limit			4.5	5.8		A
Top FET Rds on				70		m Ω
Bot FET Rds on				4.7		Ω
Maximum Duty Cycle			99			%
Switching Frequency			-10%	125	+10%	kHz
Soft-start Time				2.0		ms
Out Voltage Ripples		$C_{OUT} = 220\text{ }\mu\text{F}/22\text{ }\mu\text{F ceramic}$		80		mV
V_{OUT} Discharge Current		For high to lower voltage transitions		60		mA
Voltage transition time for QC 2.0 transition or USB PD Type C		12 V – 5 V			100	ms
Voltage transition time for QC 2.0 transition or USB PD Type C		5 V – 12 V			100	ms
Line Transient Response		Input 12 V - 40 V - 12 V with 1 V/ μ s slew rate, $V_{OUT} = 5\text{ V}$, $I_{LOAD} = 0\text{ A}$ and 2.4 A	4.75		5.25	V
Load Transient Response	$V_{OUT} = 5\text{ V}$	80 mA - 1.0 A – 80 mA load with 0.1 A/ μ s slew rate	4.9	5.15	5.4	V
	$V_{OUT} = 9\text{ V}$	80 mA - 1.0 A – 80 mA load with 0.1 A/ μ s slew rate	8.7	9.1	9.5	V
	$V_{OUT} = 12\text{ V}$	80 mA - 1.0 A – 80 mA load with 0.1 A/ μ s slew rate	11.6	12.1	12.6	V
Thermal Shut Down				160		$^\circ\text{C}$
Thermal Shut Down Hysteresis				30		$^\circ\text{C}$
ESD of DP, DM		HBM		8		kV
PDC High Threshold			2.2			V
PDC Low Threshold					0.6	V
PDC Drive Current				10		μA

FUNCTIONAL BLOCK DIAGRAM

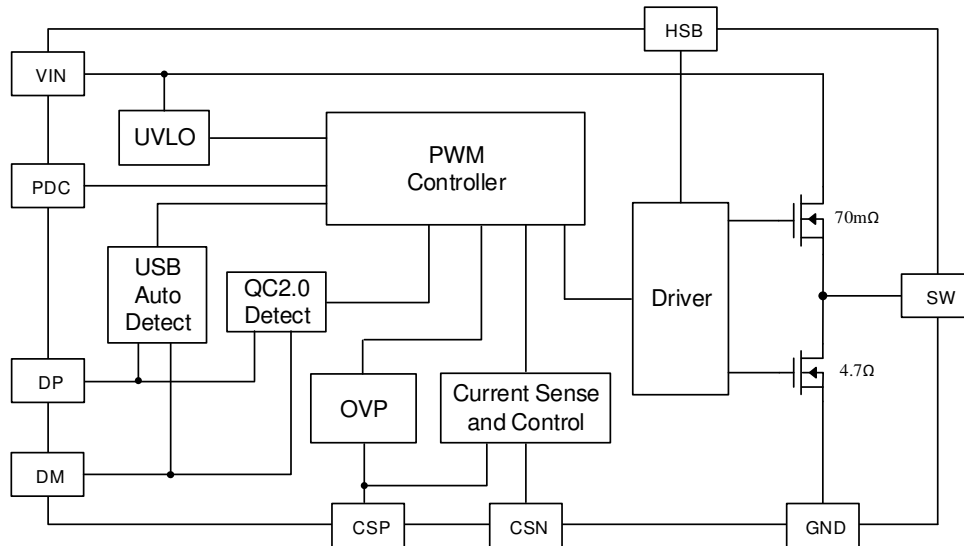

FUNCTIONAL DESCRIPTION

Output Current Sensing and Regulation

Sense resistor is connected to CSP and CSN. The sensed differential voltage is compared with interval reference to regulate current. CC loop and CV loop are in parallel. The current loop response is allowed to have slower response compared to voltage loop. However, during current transient response, the inductor current overshoot/undershoot should be controlled within +/-25% to avoid inductor saturation.

Cycle-by-Cycle Current Control

The conventional cycle-by-cycle peak current mode is implemented with high-side FET current sense.

Input Over Voltage Protection

The converter is disabled if the input voltage is above 42 V (+/-2 V). Device resumes operation automatically 40 ms after OVP is cleared.

Output Over Voltage Protection

Device stops switching when output over-voltage is sensed, and resumes operation automatically when output voltage drops to OVP- hysteresis.

Output Over Voltage Discharge

Discharge circuit starts to discharge output through CSP pins when output over voltage is detected. Discharge circuit brings 12 V down to 5 V in less than 100 ms.

Output Under-Voltage Protection / Hiccup Mode

There is a under voltage protection (UVP) threshold. If the UVP threshold is hit for 10 us, an over current or short circuit is assumed, and the converter goes into hiccup mode by disabling the converter and restarts after hiccup waiting period.

Input Brownout Protection

(ACT4529MYH-T1011 only)

If the input voltage drops below 8 V but higher than UVLO for 450 ms while in QC or PDC mode, the output voltage turns off and QC or PDC mode is disabled. If the output voltage drops below 3.7 V, the timer restarts and waits for 450 ms before attempting to restart the output voltage. When output voltage rises above 3.9 V and detects the input voltage below 8 V, timer restarts. If the input voltage is below 8 V after 450 ms, the output turns off. The cycle continues until the input voltage increases above 8.2 V, for longer than 450 ms, then output turns on, the IC renegotiates the PD and QC protocols, and normal operation restarts.

Thermal Shutdown

If the T_J increases beyond 160 °C, ACT4529 goes into HZ mode and the timer is preserved until T_J drops by 30 °C.

FUNCTIONAL DESCRIPTION

Cord Compensation

Cord Compensation increases the output voltage with increased output current to compensate for the voltage drop across the output connector and output cable.

The compensation voltage is derived as:

$$\Delta V_{OUT} = R_{CS} \cdot I_{OUT} \cdot K$$

Where R_{CS} is the current sense resistance, I_{OUT} is the load current, and $K = 3.03$

APPLICATIONS INFORMATION

Inductor Selection

The inductor maintains a continuous current to the output load. This inductor current has a ripple that is dependent on the inductance value.

Higher inductance reduces the peak-to-peak ripple current. The trade-off for high inductance value is the increase in inductor core size and series resistance, and the reduction in current handling capability. In general, select an inductance value L based on ripple current requirement:

$$L = \frac{V_{OUT} \times (V_{IN} - V_{OUT})}{V_{IN} f_{SW} I_{LOADMAX} K_{RIPPLE}} \quad (1)$$

Where V_{IN} is the input voltage, V_{OUT} is the output voltage, f_{SW} is the switching frequency, $I_{LOADMAX}$ is the maximum load current, and K_{RIPPLE} is the ripple factor. Typically, choose $K_{RIPPLE} = 30\%$ to correspond to the peak-to-peak ripple current being 30% of the maximum load current.

With a selected inductor value the peak-to-peak inductor current is estimated as:

$$I_{LPK-PK} = \frac{V_{OUT} \times (V_{IN} - V_{OUT})}{L \times V_{IN} \times f_{SW}} \quad (2)$$

The peak inductor current is estimated as:

$$I_{LPK} = I_{LOADMAX} + \frac{1}{2} I_{LPK-PK} \quad (3)$$

The selected inductor should not saturate at I_{LPK} . The maximum output current is calculated as:

$$I_{OUTMAX} = I_{LIM} - \frac{1}{2} I_{LPK-PK} \quad (4)$$

I_{LIM} is the internal current limit.

Input Capacitor

The input capacitor needs to be carefully selected to maintain sufficiently low ripple at the supply input of the converter. A low ESR capacitor is highly recommended. Since large current flows in and out of this capacitor during switching, its ESR also affects efficiency.

The input capacitance needs to be higher than 10 μF . The best choice is the ceramic type. However, low ESR tantalum or electrolytic types may also be used provided that the RMS ripple current rating is higher than 50% of the output current. The input capacitor should be placed close to the IN and GND pins of the IC, with the shortest traces possible. In the case of tantalum or electrolytic types, a ceramic capacitor is recommended to parallel

with tantalum or electrolytic capacitor, which should be placed right next to the IC.

Output Capacitor

The output capacitor also needs to have low ESR to keep low output voltage ripple. The output ripple voltage is:

$$V_{RIPPLE} = I_{LPK-PK} \times \left(R_{ESR} + \frac{1}{8 \times f_{SW} \times C_{OUT}} \right) \quad (5)$$

Where I_{OUTMAX} is the maximum output current, K_{RIPPLE} is the ripple factor, R_{ESR} is the ESR of the output capacitor, f_{SW} is the switching frequency, L is the inductor value, and C_{OUT} is the output capacitance. From the equation above, V_{RIPPLE} is the combination of ESR and real capacitance.

In the case of ceramic output capacitors, R_{ESR} is very small and does not contribute to the ripple. Therefore, a lower capacitance value can be used for ceramic type. In the case of tantalum or electrolytic capacitors, the ripple is dominated by R_{ESR} multiplied by the ripple current. In that case, the output capacitor is chosen to have sufficiently low ESR.

For ceramic output capacitor, typically choose a capacitance of about 22 μF . For tantalum or electrolytic capacitors, choose a capacitor with less than 50 m Ω ESR. If an 330 μF or 470 μF electrolytic cap or tantalum cap is used, where ripple is dominantly caused by ESR, an 2.2 μF ceramic in parallel is recommended.

Rectifier Schottky Diode

Use a Schottky diode as the rectifier to conduct current when the High-Side Power Switch is off. The Schottky diode must have current rating higher than the maximum output current and a reverse voltage rating higher than the maximum input voltage. Furthermore, the low forward voltage Schottky is preferable for high efficiency and smoothly operation.

APPLICATIONS INFORMATION

Current Sense Resistor

The traces leading to and from the sense resistor can be significant error sources. With small value sense resistors, trace resistance shared with the load can cause significant errors. It is recommended to connect the sense resistor pads directly to the CSP and CSN pins using “Kelvin” or “4-wire” connection techniques as shown below.

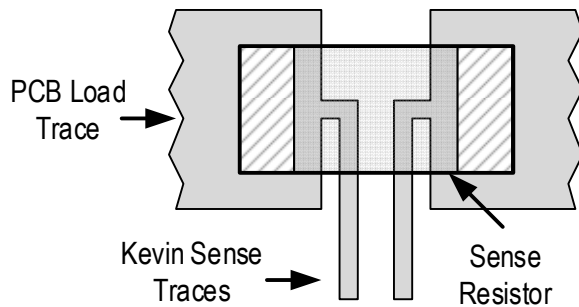

Current Limit Setting

When the output current reaches current limit, the IC limits the peak switch current on a cycle-by-cycle basis. This reduces the output voltage to keep the output current at a constant value.

The following equation calculates the peak current limit.

$$I_{Limit} (A) = \frac{66 \text{ mV}}{R_{cs} (m\Omega)} \quad (6)$$

Where R_{cs} is current sense resistor.

The maximum, output current is defined by

$$I_{LOADMAP} = I_{Limit} - \frac{1}{2} I_{LPK-PK} \quad (7)$$

APPLICATIONS INFORMATION

PCB Layout Guidance

When laying out the printed circuit board, the following checklist should be used to ensure proper operation of the IC.

1. Arrange the power components to reduce the AC loop size consisting of C_{IN} , V_{IN} pin, SW pin and the Schottky diode and GND.
2. Place input decoupling ceramic capacitor C_{IN} as close to V_{IN} pin as possible. The GND side of C_{IN} must be placed as close as possible to power GND on the top layer. The traces should be short and wide.
3. The high power loss components, e.g. the controller, Schottky diode, and the inductor should be placed carefully to make the thermal spread evenly on the board.
4. Schottky anode pad and IC exposed pad should be placed close to ground clips in CLA applications
5. Use “Kelvin” or “4-wire” connection techniques from the sense resistor pads directly to the CSP and CSN pins. The CSP and CSN traces should be in parallel to avoid interference.
6. Place multiple vias between top and bottom GND planes for best heat dissipation and noise immunity.
7. Use short traces connecting HSB- C_{HSB} -SW loop.
8. SW node is noisy, switching from V_{IN} to GND. Its size should be minimized and it should be isolated away from the rest of circuit for good EMI and low noise operation.

Example PCB Layout

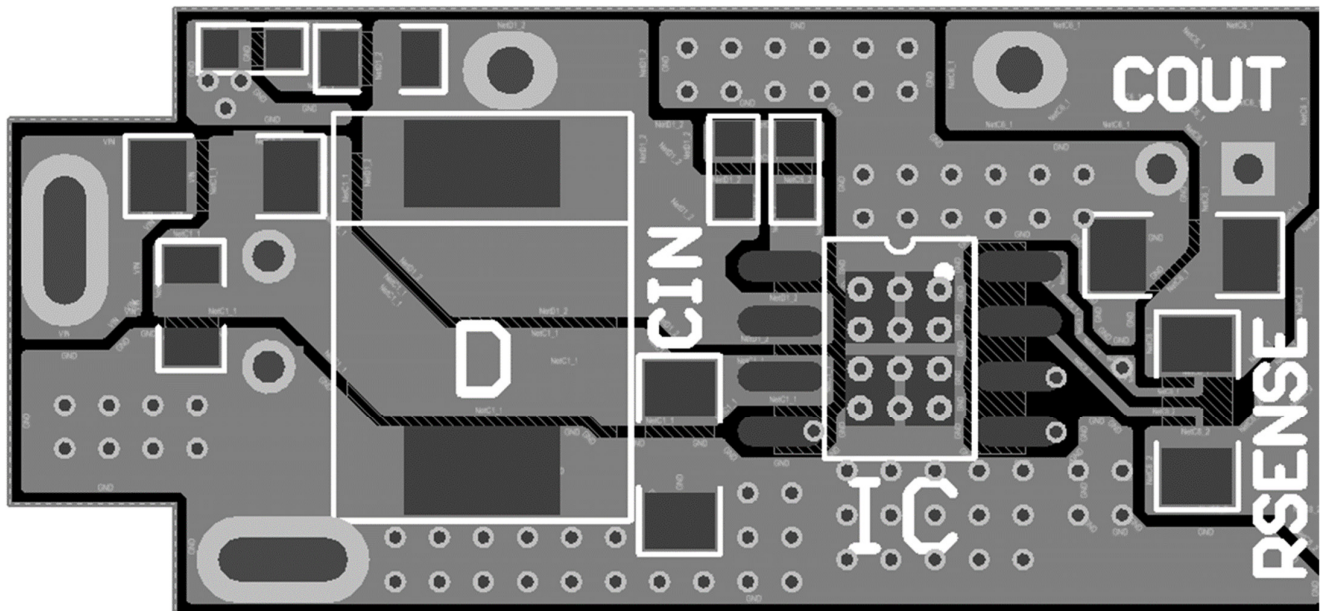

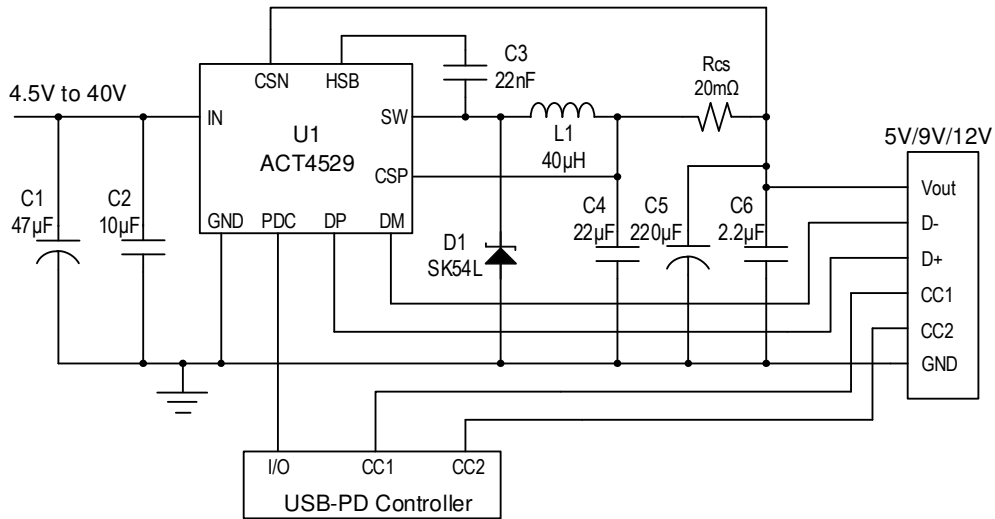
Typical Application Circuit

BOM List for 2.4 A Car Charger

ITEM	REFERENCE	DESCRIPTION	MANUFACTURER	QTY
1	U1	IC, ACT4529, SOP-8EP	Active-Semi	1
2	C1	Capacitor, Electrolytic, 47 µF/35 V	Murata, TDK	1
3	C2	Capacitor, Ceramic, 10 µF/25 V, 1206, SMD	Murata, TDK	1
4	C3	Capacitor, Ceramic, 22 nF/25 V, 0603, SMD	Murata, TDK	1
5	C4	Capacitor, Ceramic, 22 µF/16 V, 1206, SMD	Murata, TDK	1
6	C5	Capacitor, Electrolytic, 220 µF/16 V	Murata, TDK	1
7	C6	Capacitor, Ceramic, 2.2 µF/16 V, 0805, SMD	Murata, TDK	1
8	L1	Inductor, 40 µH, 4 A, 20%		1
9	D1	Diode, Schottky, 40 V/5 A, SK54L	Panjit	1
10	Rcs	Chip Resistor, 20 mΩ, 1206, 1%	Murata, TDK	1

TYPICAL PERFORMANCE CHARACTERISTICS

(Schematic as shown in typical application circuit, $T_A = 25\text{ }^\circ\text{C}$, unless otherwise specified)

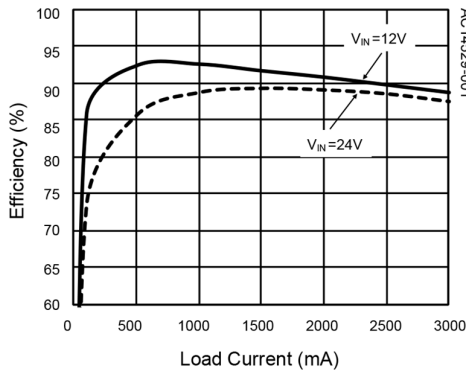
Efficiency vs. Load current (5V Vout)



Efficiency vs. Load current (9V Vout)

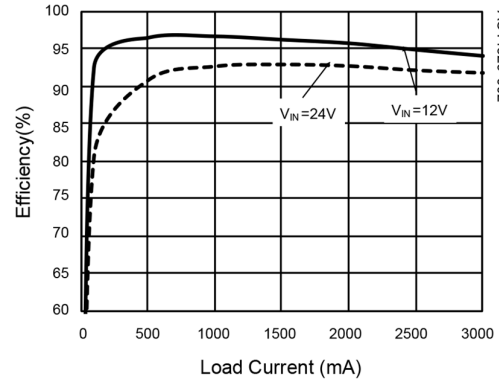

Efficiency vs. Load current (12V Vout)

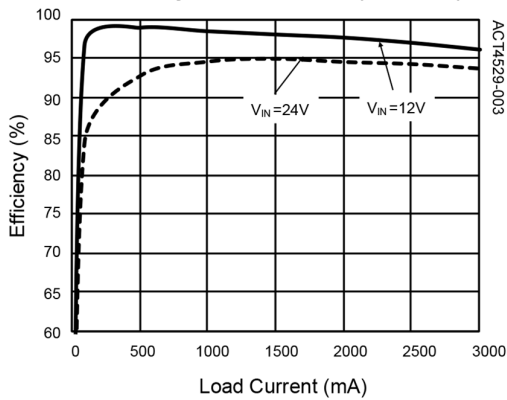

Output CC/CV Curve (5V Vout)

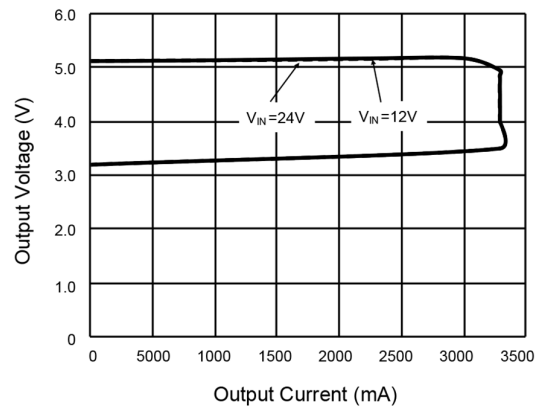

Output CC/CV Curve (9V Vout)

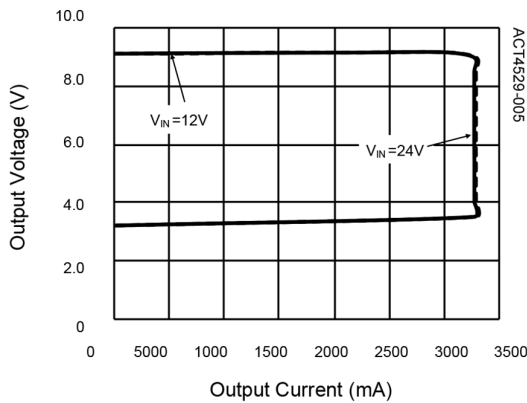

Output CC/CV Curve (12V Vout)

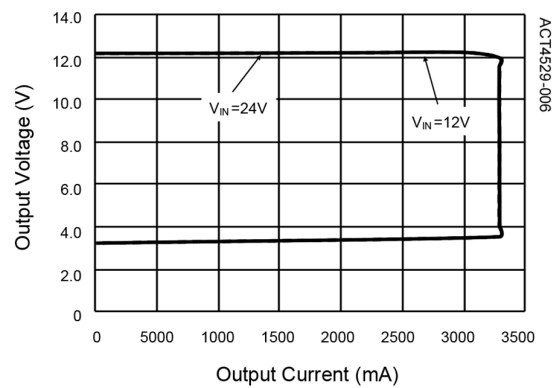

TYPICAL PERFORMANCE CHARACTERISTICS

(Schematic as shown in typical application circuit, $T_A = 25\text{ }^\circ\text{C}$, unless otherwise specified)

Output Over Voltage (5V Vout)

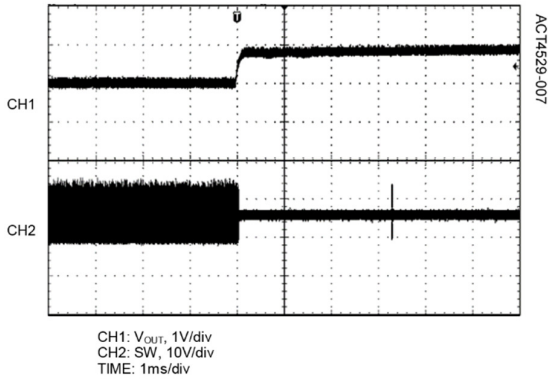

Start up into CC Mode

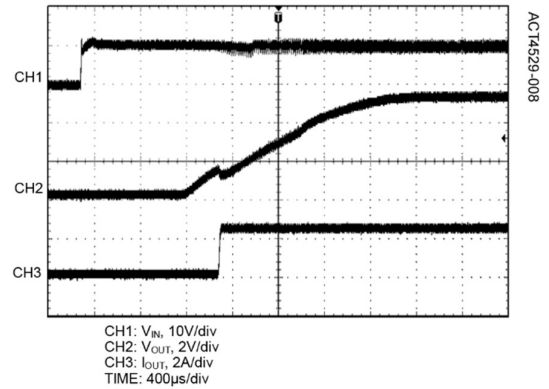

Load Transient (80mA-1A-80mA)
 $V_{in}=12V, V_{out}=5V$

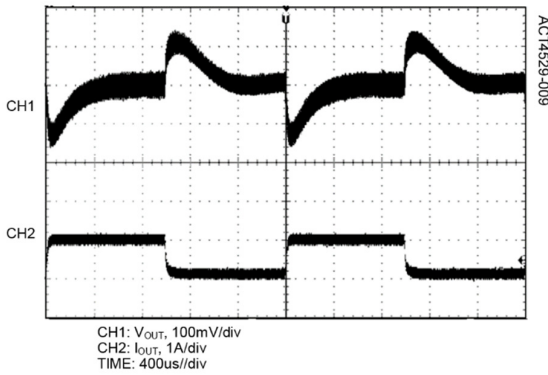

Load Transient (1A-2.4A-1A)
 $V_{in}=12V, V_{out}=5V$

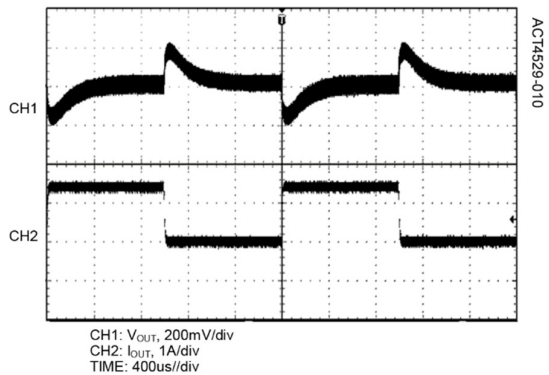

Load Transient (80mA-1A-80mA)
 $V_{in}=12.6V, V_{out}=12V$

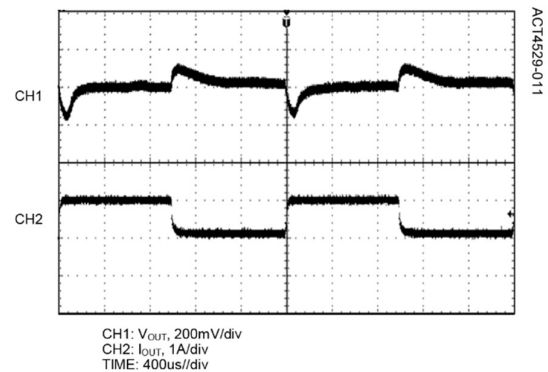

Load Transient (1A-2.4A-1A)
 $V_{in}=12.6V, V_{out}=12V$

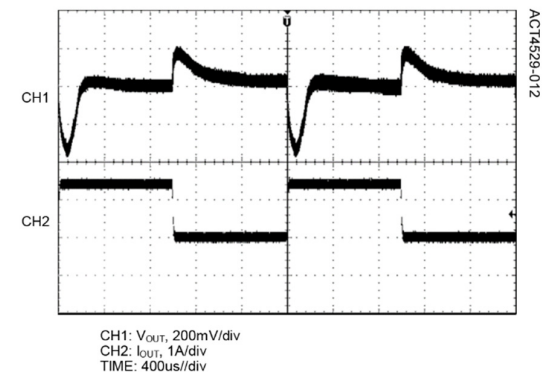

TYPICAL PERFORMANCE CHARACTERISTICS

(Schematic as shown in typical application circuit, $T_A = 25\text{ }^\circ\text{C}$, unless otherwise specified)

Voltage Transient (5V-9V)

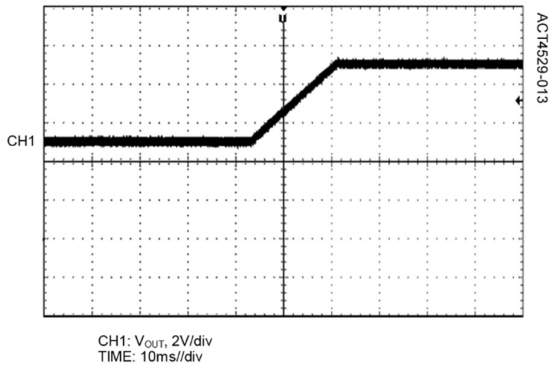

Voltage Transient (9V-5V)

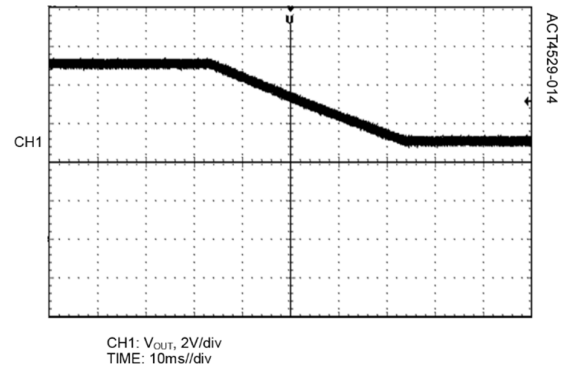

Voltage Transient (5V-12V)

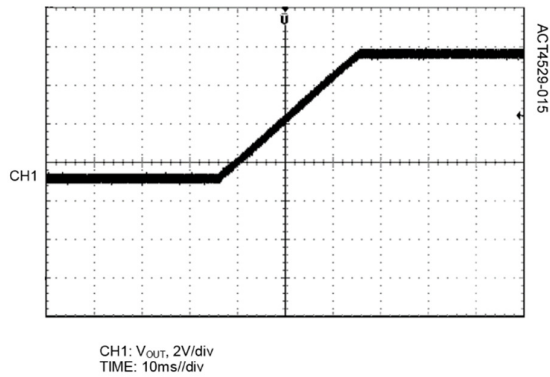

Voltage Transient (12V-5V)

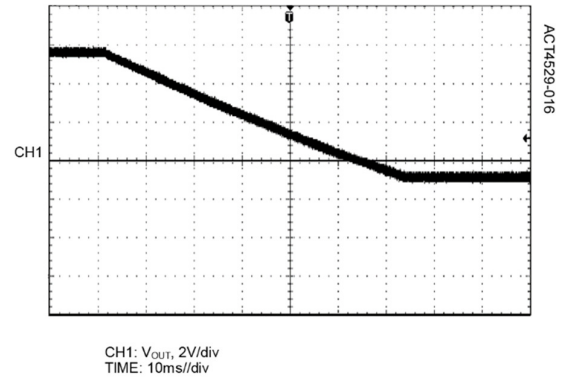

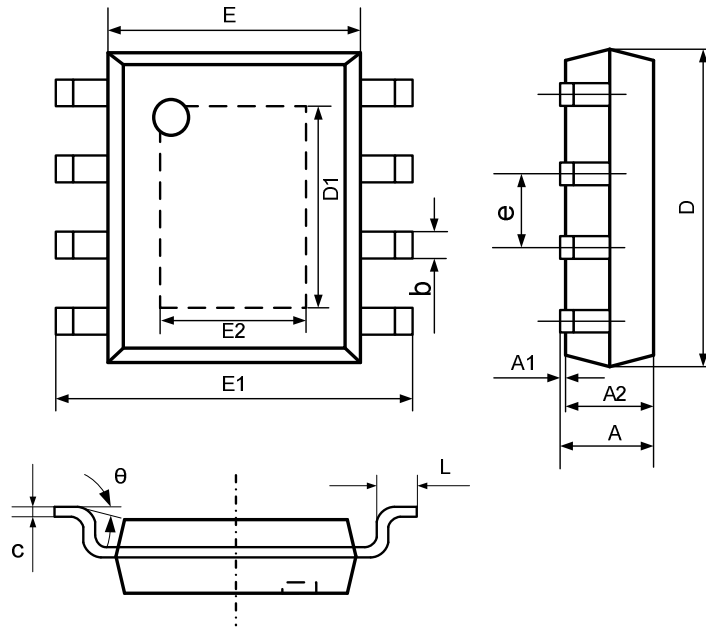
PACKAGE OUTLINE
SOP-8 EP PACKAGE OUTLINE AND DIMENSIONS

SYMBOL	DIMENSION IN MILLIMETERS		DIMENSION IN INCHES	
	MIN	MAX	MIN	MAX
A	1.350	1.727	0.053	0.068
A1	0.000	0.152	0.000	0.006
A2	1.245	1.550	0.049	0.061
b	0.330	0.510	0.013	0.020
c	0.170	0.250	0.007	0.010
D	4.700	5.100	0.185	0.200
D1	3.202	3.402	0.126	0.134
E	3.734	4.000	0.147	0.157
E1	5.800	6.200	0.228	0.244
E2	2.313	2.513	0.091	0.099
e	1.270 TYP		0.050 TYP	
L	0.400	1.270	0.016	0.050
theta	0°	8°	0°	8°