

**ACT88321EVK1-101 User's Guide**

**Description**

This document describes the characteristic and operation of the Qorvo ACT88321EVK1-101 evaluation kit (EVK). It provides setup and operation instructions, schematic, layout, BOM, and test data. This EVK demonstrates the ACT88321VU101 Qorvo PMU power management IC. Other ACT88321VUxxx options can be evaluated on this EVK by replacing the IC and any other necessary components.

**Features**

The EVK can be used as a standalone board if desired. However, to access the internal registers and to take full advantage of the IC's capability, the user must connect the EVK kit to a PC with Qorvo's USB-TO-I2C interface dongle and use the GUI software. The EVK provides full access to each converter's input and output voltage, as well as all the digital control signals. This gives the user the flexibility to configure the EVK to match their real-world system.

Note that the ACT88321EVK1-101 is specifically configured for the ACT88321VU101. This CMI does not use Push-Button.



Figure 1 – EVK Picture

## Setup

### Required Equipment

ACT88321 EVK

USB-TO-I2C Dongle

Power supply – 3.3V @ 4A for full power operation

Oscilloscope – >100MHz, >2 channels

Loads – Electronic or resistive. 3A minimum current capability.

Digital Multi-meters (DMM)

Windows compatible computer with spare USB port.

### EVK Setup

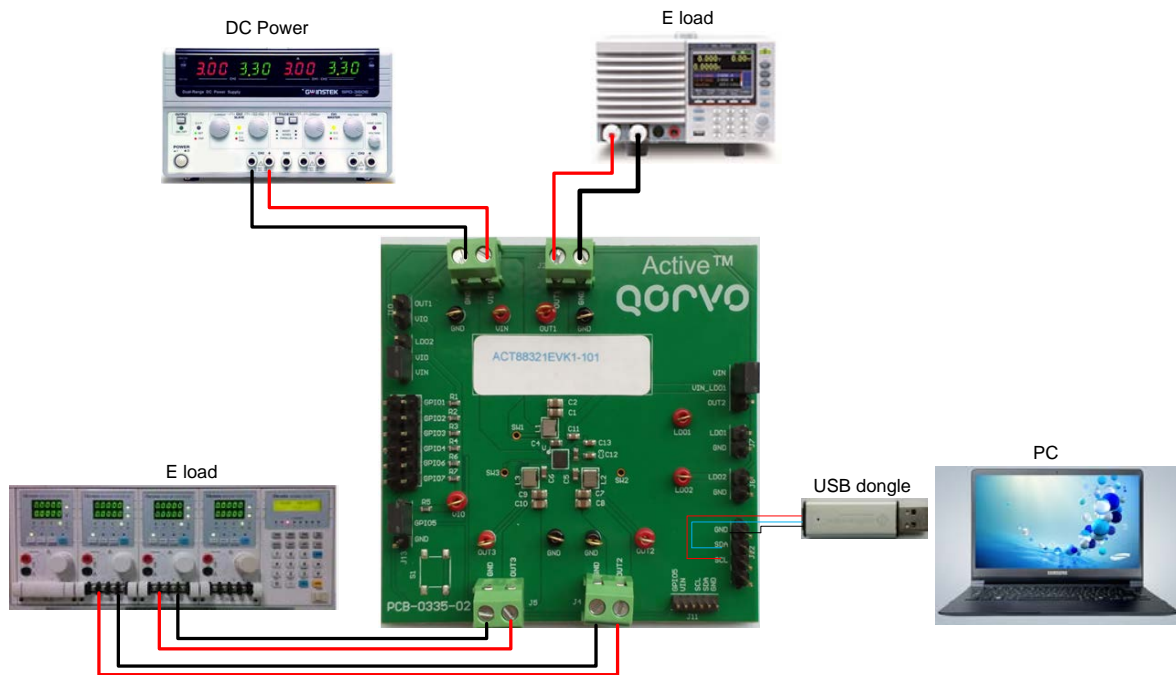

Figure 2 – EVK Setup

### Hardware Setup

1. Decide which voltage will power VIO\_IN. Qorvo recommends powering VIO\_IN from the VIN input. Connect a shorting jumper between J9-2 and J9-3 header to power VIO\_IN from the VIN input voltage.
2. Connect a jumper between J3-1 and J3-2 header to power VIN\_LDO1 from VIN input voltage.
3. Connect a jumper between J13-1 and J13-2 to power GPIO5.
4. Connect DC source between J1-1 and J1-2 with 3.3V.
5. Connect an appropriate load to each power supply output.
6. Note that the typical setup is to apply the same 3.3V input voltage to all inputs. Using different input voltage sources requires careful consideration of startup sequencing.



Figure 3 – Shorting Jumper Settings

## GUI Setup (optional)

1. Refer to the end of this document for detailed instructions to install the ACT88321 GUI.
2. Connect the USB-TO-I2C dongle to the computer via a USB cable.
3. Connect the USB-TO-I2C dongle to the EVK J12 connector. Refer to Figure 4 to ensure the correct polarity of the connection. As a guide, use the “Active-Semi” logo on the top of the dongle so the black wire is connected toward the lower left corner of the Dongle.

Dongle Cable Connector (Black Wire Connected to GND of the J12 I2C Jumper on the ACT88321 EVK Board)



Figure 4 – USB-TO-I2C Dongle Connection

## Recommended Operating Conditions

The ACT88321EVK1-101 is designed for a 3.3V input voltage. The maximum operating voltage is determined by the IC's maximum input voltage rating. The minimum operating voltages are determined by the buck converters' minimum input voltage and by the LDOs' dropout voltages. Maximum currents are determined by the IC's CMI settings, which can be changed via I2C after startup.

**Table 1. Recommended Operating Conditions**

PARAMETER	VALUE	UNIT
All I/O and Power pins except PGND1, PGND2, PGND3, AGND	-0.3 to 6	V
Grounds: Any PGND referenced to AGND	-0.3 to +0.3	V
SW_Bx to PGNDx	-1 to VIN_Bx + 1	V
FB_Bx to PGNDx	-0.3 to AVIN + 0.3	V
LDO2 to AGND	-0.3 to AVINx + 0.3	V
LDO1 to AGND	-0.3 to VIN_LDO + 0.3	V
Junction to Ambient Thermal Resistance, CSP	37	°C/W
Operating Junction Temperature	-40 to 150	°C
Storage Temperature	-55 to 150	°C

## EVK Operation

### Turn-on

Apply the 3.3V input voltage. All outputs automatically turn on with the programmed startup sequence.

### Test Results

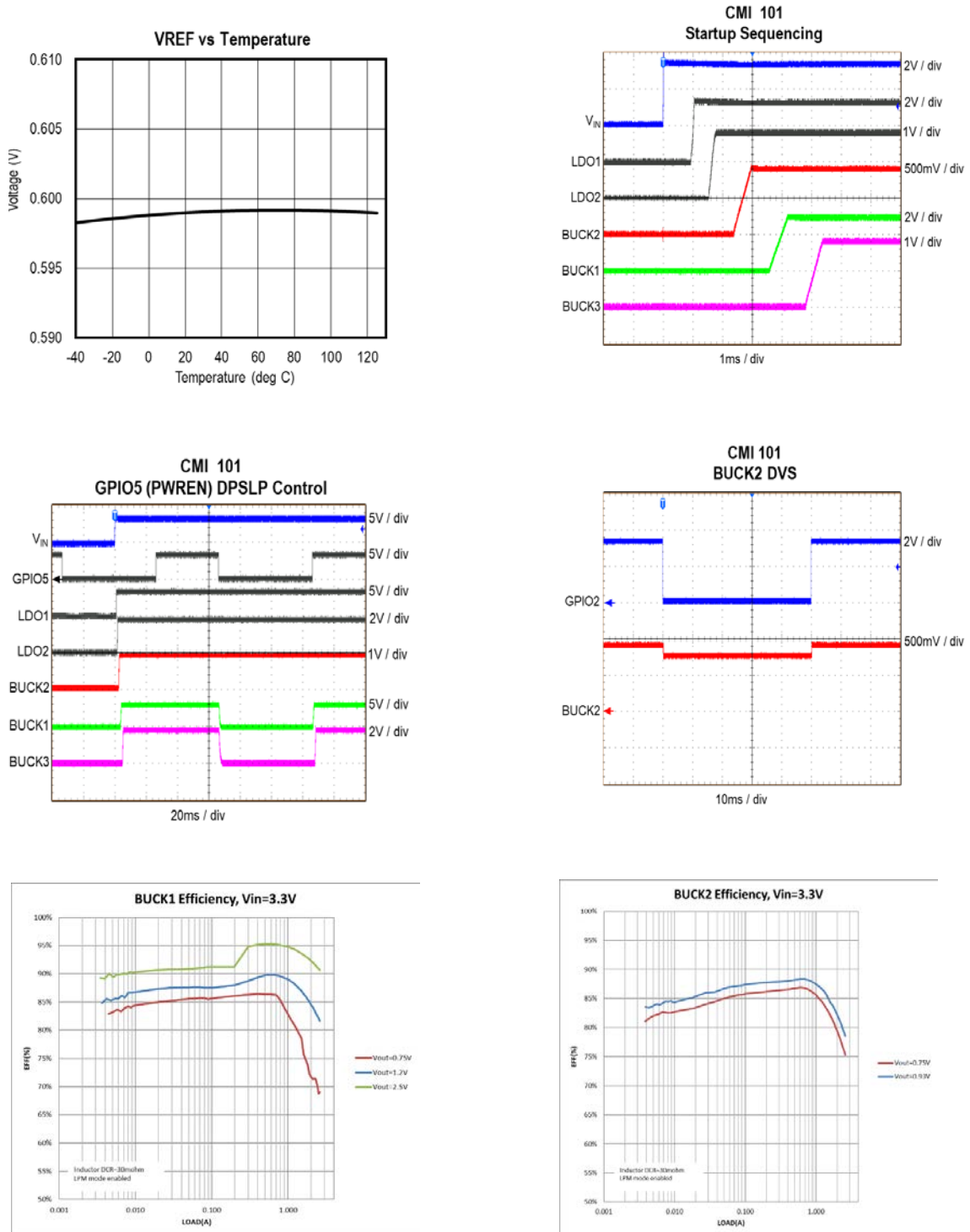

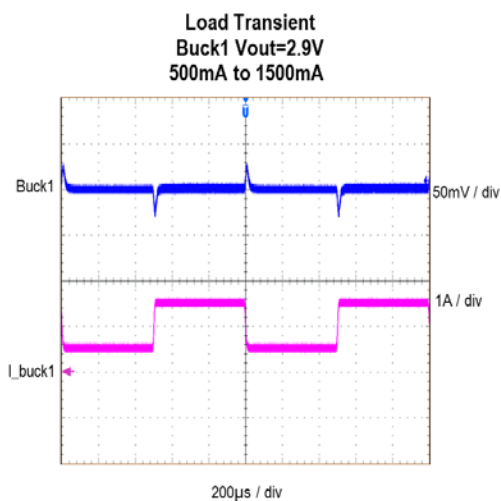
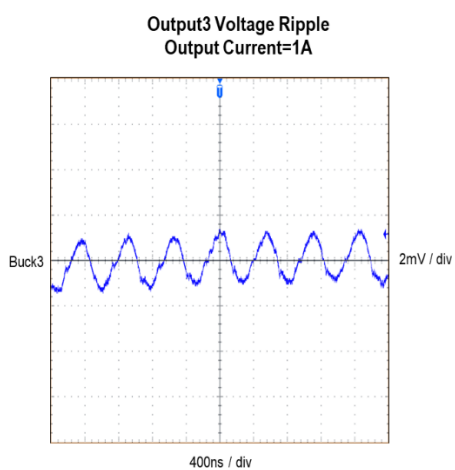
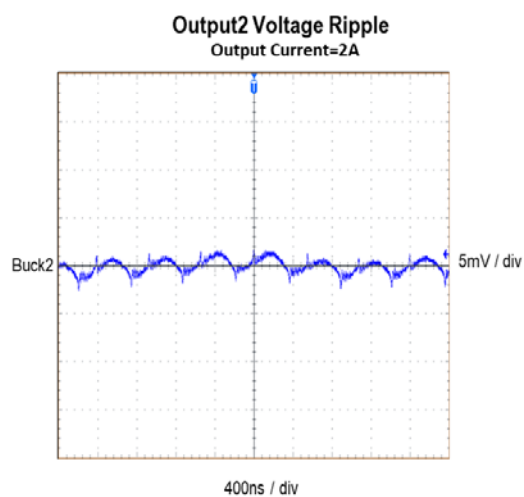
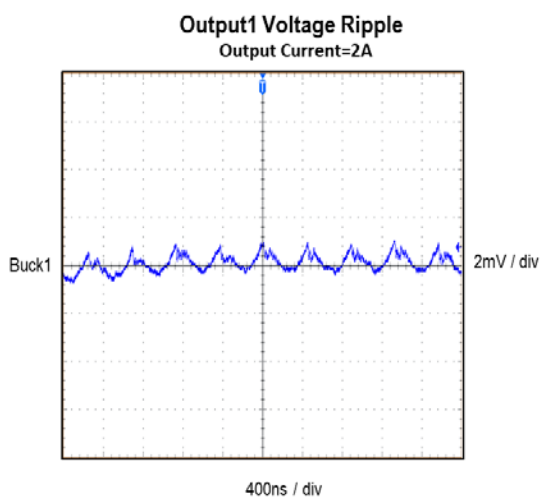
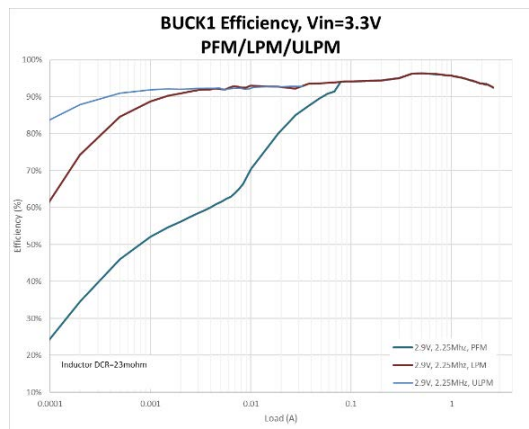
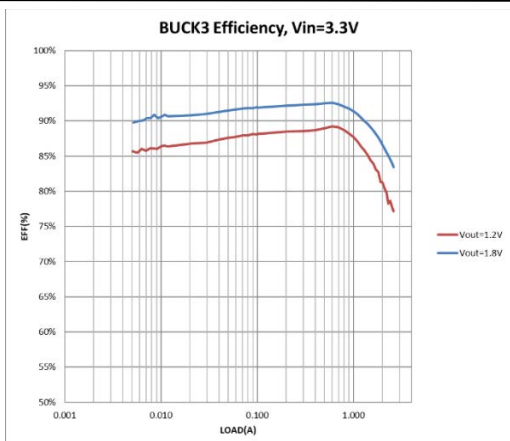

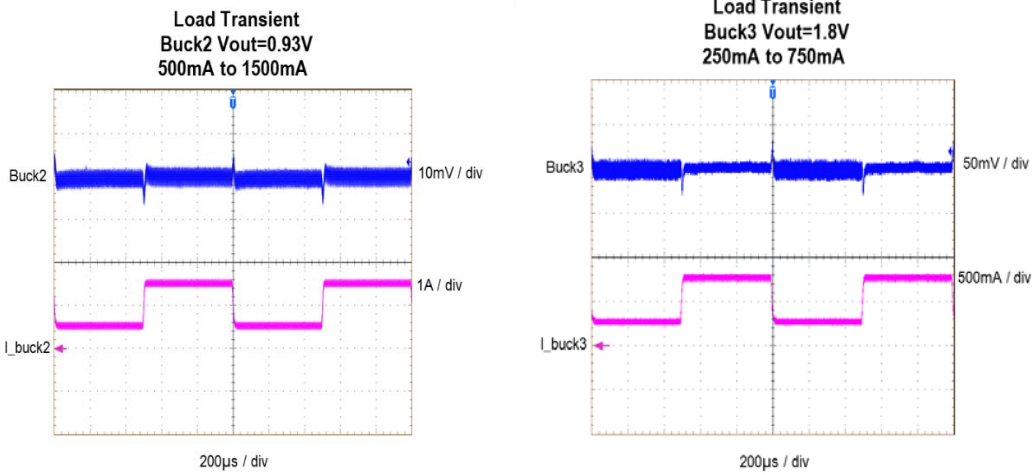

Schematic

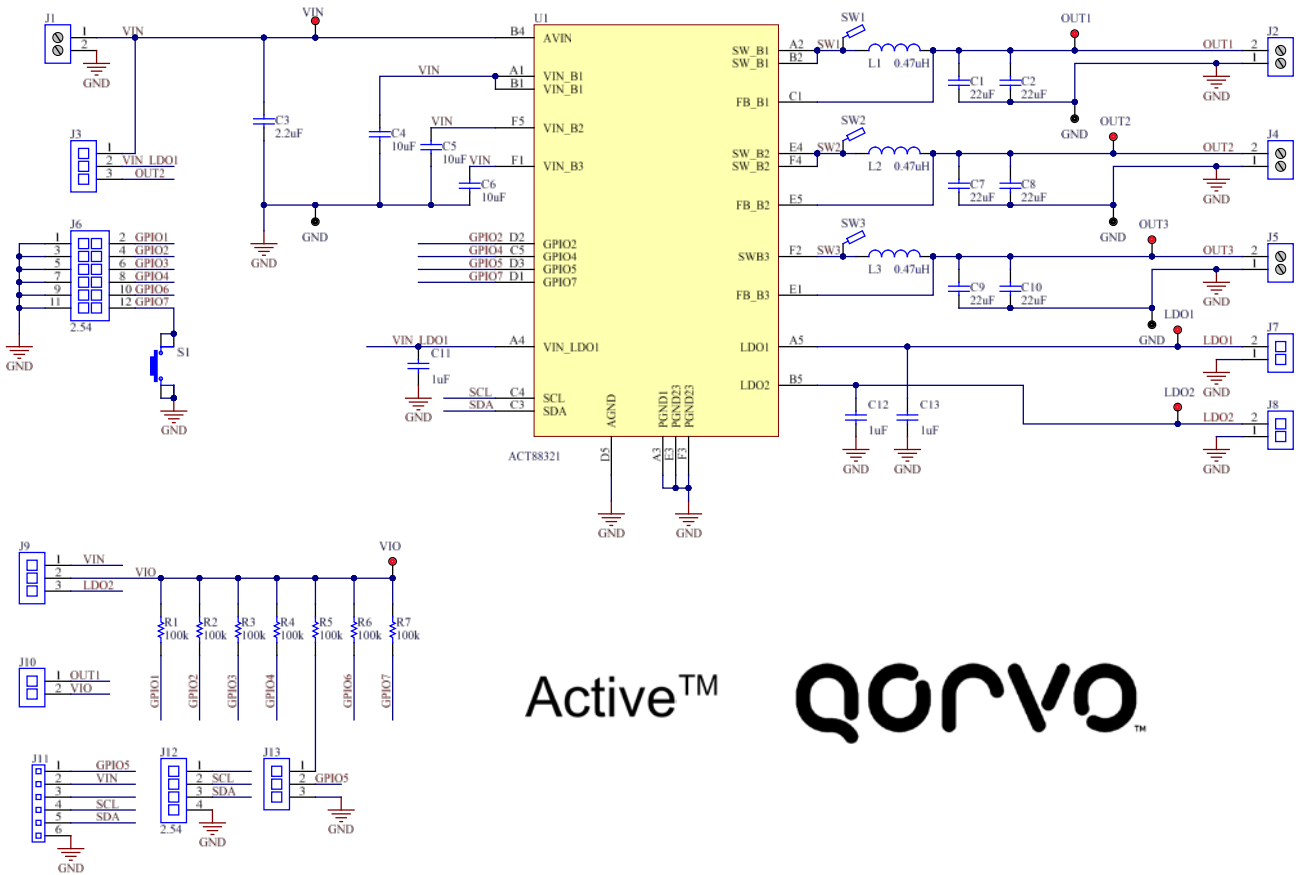

Figure 5 – ACT88321EVK1-101 Schematic



**Bill of Materials**
**Table 2 - BOM**

Item	Designator	Quantity	Description	Package	Manufacturer	PartNumber
1	C1, C2, C7, C8, C9, C10	6	Cap, Ceramic, 22uF, 16V, 20%, X5R	0805	std	std
2	C3	1	Cap, Ceramic, 2.2uF, 16V, 20%, X5R	0603	std	std
3	C4, C5, C6	3	Cap, Ceramic, 10uF, 16V, 20%, X5R	0603	std	std
4	C11, C12, C13	3	Cap, Ceramic, 1uF, 16V, 20%, X5R	0603	std	std
5	J1, J2, J4, J5	4	CON, Screw Terminal, 3.50, 2P, KF350		Wurth Elektronik	691214110002
6	J3, J9	2	Header, Unshrouded, 2.54, Male, 3P	CON3	Wurth Elektronik	61300211121
7	J6	1	Header, Unshrouded, 2.54, Male, 7x2P	CON7x2	Wurth Elektronik	61301421121
8	J7, J8, J10	3	Header, Unshrouded, 2.54, Male, 2P	CON2	Wurth Elektronik	61300211121
9	J11	1	Header, Unshrouded, 1.27, Male, 6P	CON6	Digekey	GRPB061VWVN-RC
10	J12	1	Header, Unshrouded, 2.54, Male, 4P	CON4	Wurth Elektronik	61300211121
11	L1, L2, L3	3	Inductor, 0.47uH	2512	Wurth Elektronik	744383240047
12	R1, R2, R3, R4, R5, R6, R7	7	Res, 100kΩ, 5%	0603	std	std
13	S1	0	Switch, TSW, TE-1437565-0		N/A	std
14	TP1, TP2, TP3, TP5, TP8, TP10, TP11	7	TEST POINT PC MINI .040"D RED		KeyStone	5000
15	TP4, TP6, TP7, TP9	4	TEST POINT PC MINI .040"D BLK		KeyStone	5001
16	U1	1	IC, ACT88321	CSP	Qorvo	ACT88321VU101



## Layout

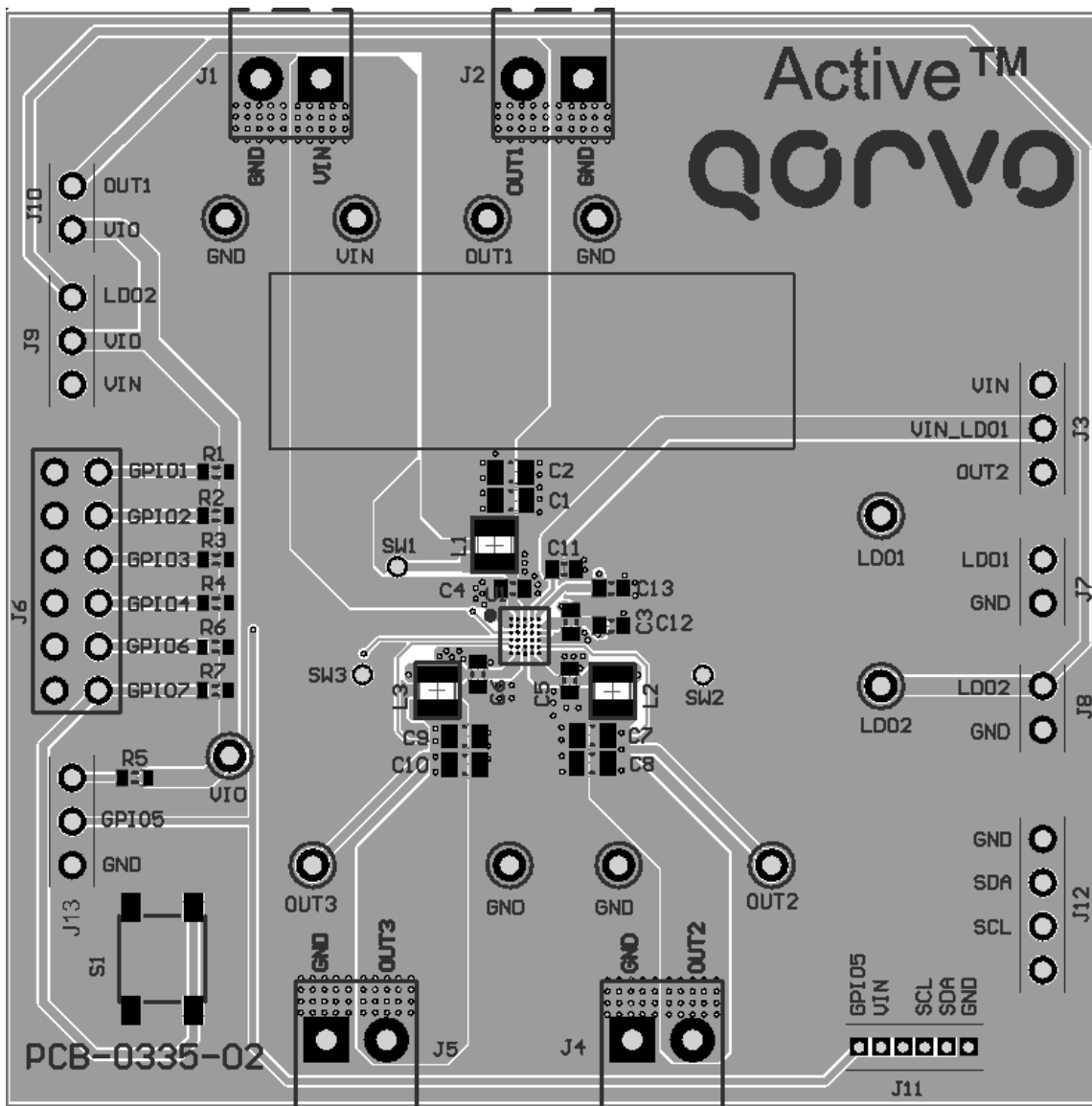

Figure 6 – Layout Top Assembly

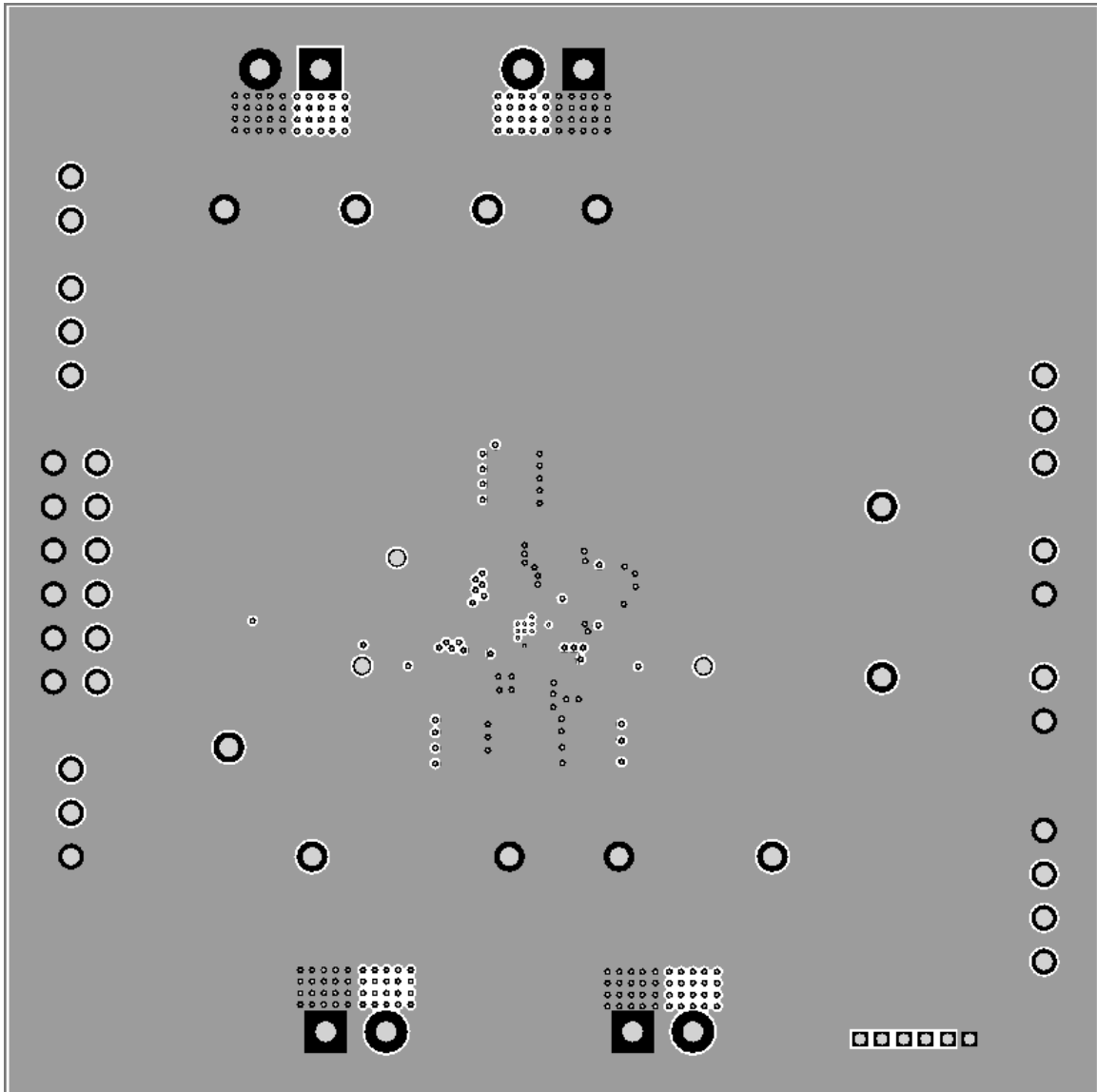

Figure 7 – Layout Layer 2

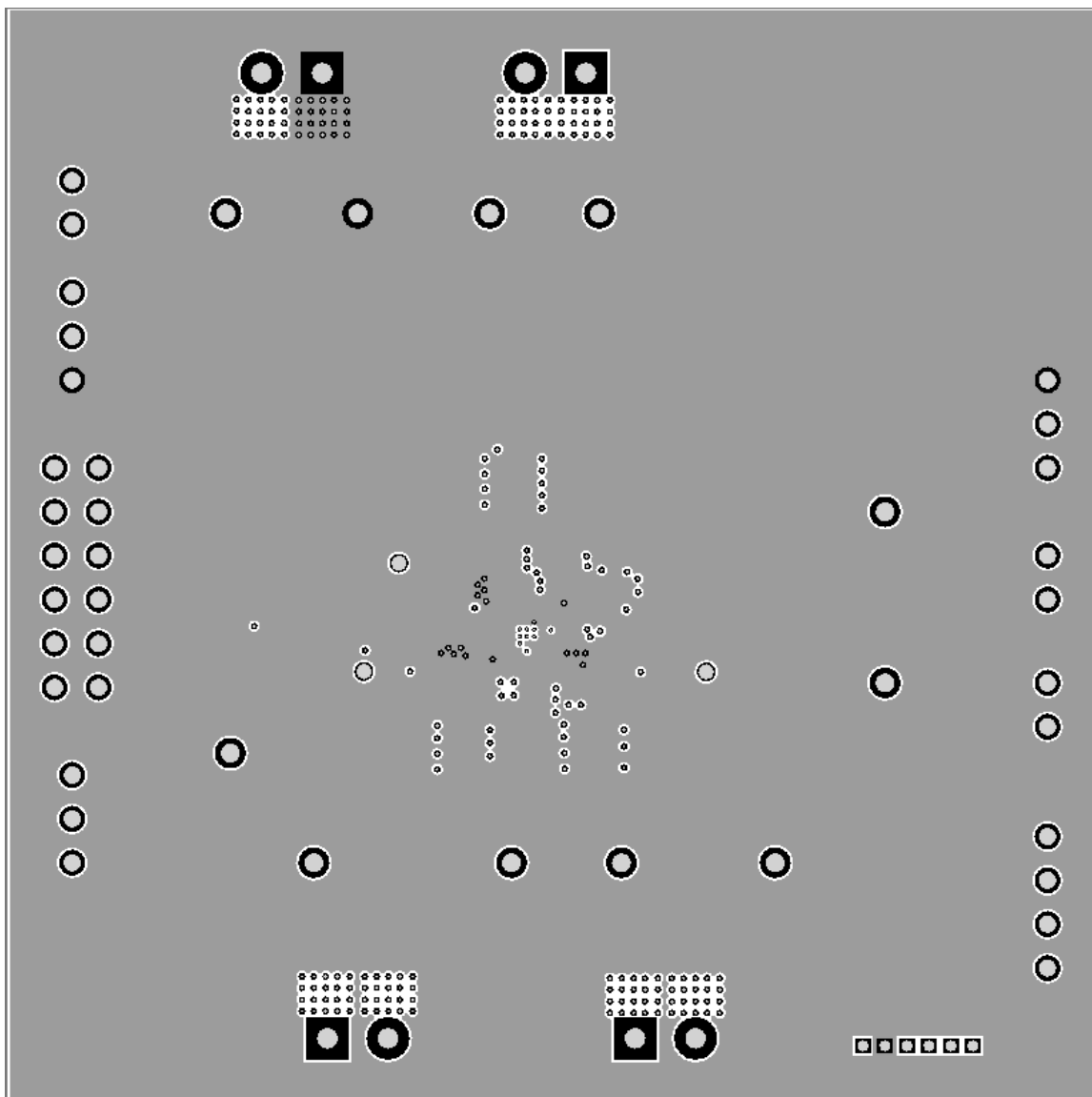

Figure 8 – Layout Layer 3

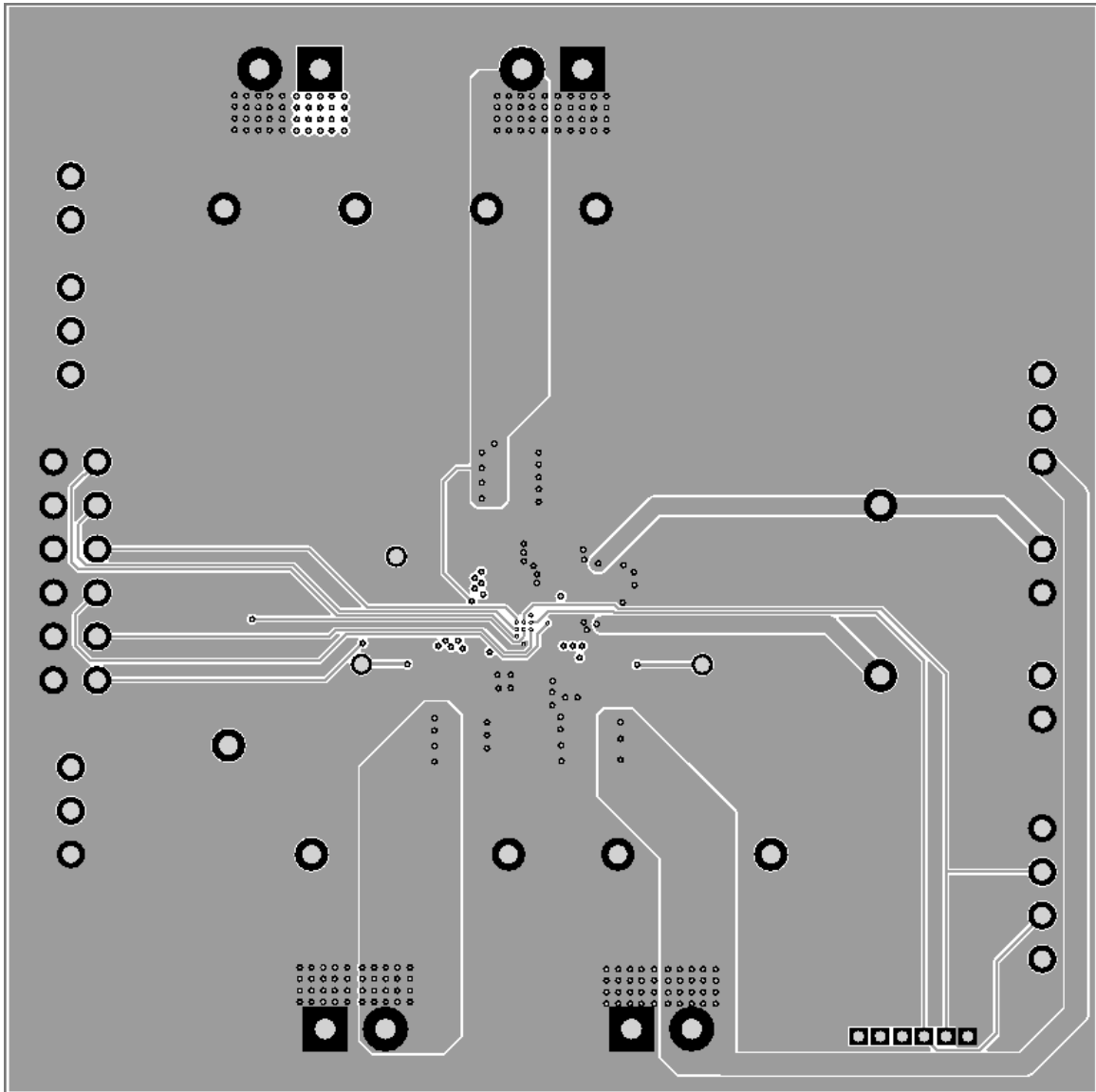

Figure 9 – Layout Bottom Layer

## GUI Installation

1. Download the GUI files from Qorvo's website and save them on your computer.
2. Plug the USB-TO-I2C dongle into a free USB port.
3. Double click on the ACT88321 GUI.exe to start the ACT88321 GUI.

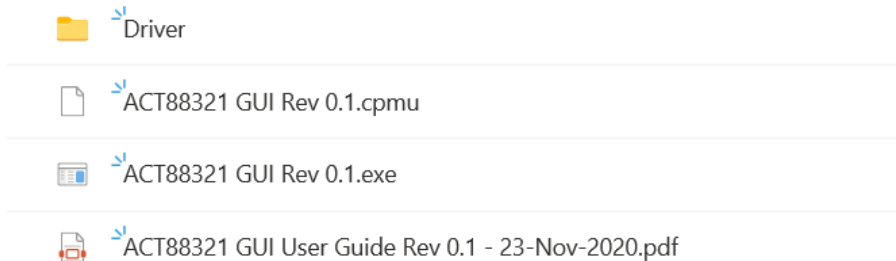

Figure 10 – Dongle Driver

## GUI Overview

The GUI has 2 basic function buttons allocated in top-left of the Tool Bar which are Read and Write I2C. The GUI contains 2 setting modes: Basic Mode and Advanced Mode. In Basic Mode screen it displays basic user programmable configuration options are programmed using the drop-down boxes or check boxes. Advanced Mode contains the button text for changing setting for every single bit.

### Basic Mode

The following figure shows the GUI in basic mode. This mode allows the user to easily change one or more IC settings.

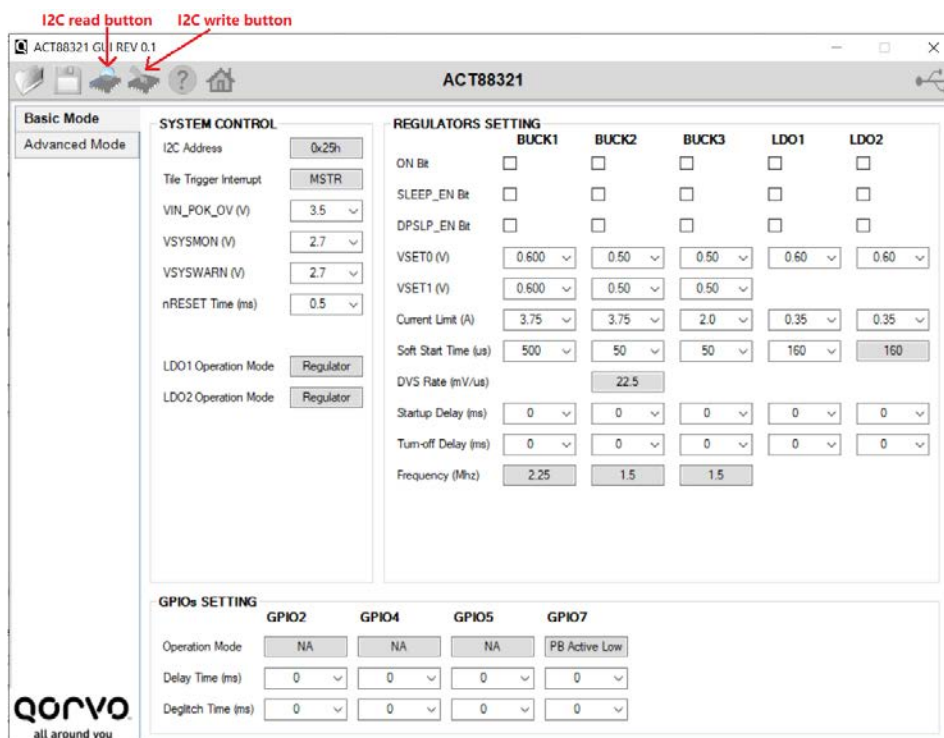

Figure 11 – GUI Basic Mode

**Advanced Mode**

Click the “Advanced Mode” button in the left of the GUI screen to see all available user programmable options. With Advanced Mode, additional user programmable features can be selected using the button text. In the left side of the Advanced Mode Screen, click on the Tiles Selector to display the register to view or change. Then change a register one bit at a time by clicking on the desired bit. The value of the bit is display right next to the bit-name button.

Note that the right side of the screen contains a scroll down button to scroll down to additional registers since the Tile Screen can only display up to 8 bytes at once.

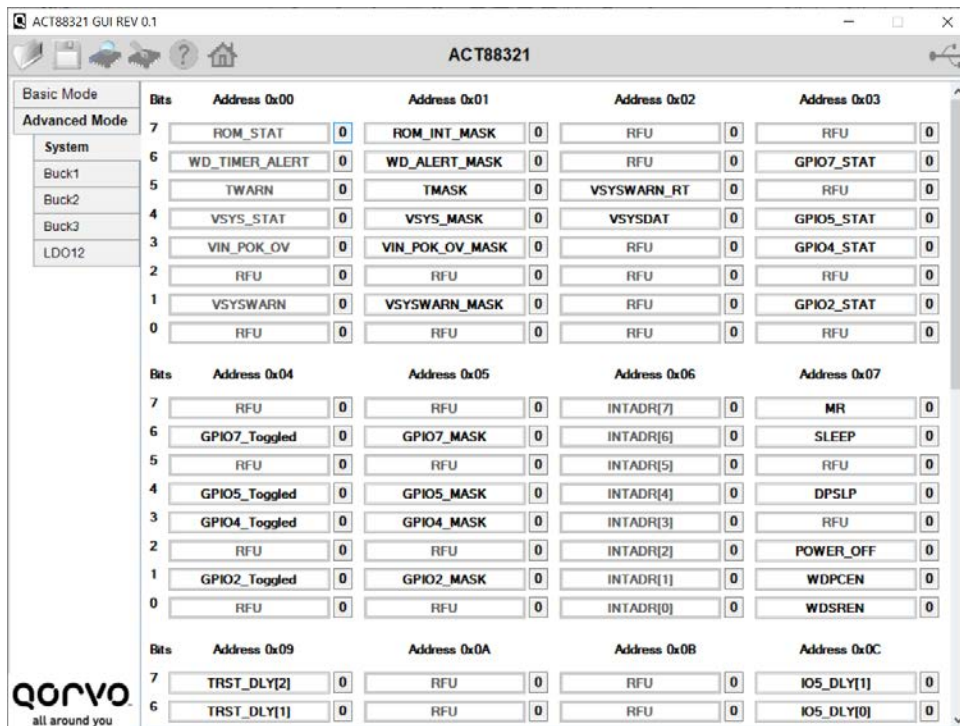

Figure 12 – GUI Advanced Mode

**Button Descriptions**

**Read:** Clicking on this button reads the ACT88321 registers and displays them in the GUI. Note that this reads all registers. Qorvo recommend spreading registers each time the ACT88321 powers-up to acquire the initial register settings. Qorvo also recommends reading registers after making changes to them. Immediately reading the registers after a write confirms the changes were properly stored.

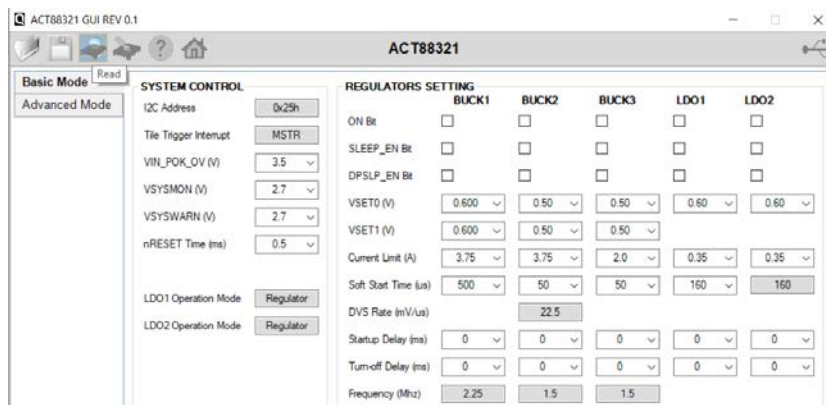

Figure 13 – Read Button