



| ACW4 CANopen

CANOPEN ABSOLUTE SINGLE TURN MODULAR



Features

- With its two-part design, the ACW4 CANopen absolute single-turn offers maximum flexibility for installation
- Rugged and excellent resistance to shock and vibration
- Robust, proven magnetic technology
- Environmentally resistant, IP 67 standard (IP69K option)
- Extended operating range from -30° C to 85° C
- Uses universal supply 5 to 30 VDC – CAN open output
- Available Resolution up to 12 bits per revolution
- Variety of magnet holders available
- Standard PVC cable with SUBD9 connector

Applications

- Factory Automation
- Process Automation



SPECIFICATIONS

Mechanical

Terminations	PVC Cable with SUBD9 connector
Housing	Macromelt PA638
Weight	0,150 kg

Electrical

Electrical Angle	360°
Output Function	CANopen
Minimal Cycle Time	< 400µs
Resolution	Single –turn, 12 bits
Accuracy	+/-0.3% on 360°
Repeatability	+/-0.1% on 360°
Supply Voltage	5 to 30 Vdc
Start-up	< 1 s
Current Requirements	< 40mA
Protection	Overvoltage Protection: Yes Reverse Polarity Protection: Yes Short Circuit Protection: Yes
EMC	IEC 61000-4-2 Electrostatic discharge (ESD) 4 kV, 8 kV IEC 61000-4-3 Electromagnetic fields 10 V/m (80MHz - 1GHz), 3V/m (1.4GHz - 2GHz), 1V/m (2GHz - 2.7GHz) IEC 61000-4-4 Electrical fast transients (burst) 1 kV IEC 61000-4-6 Conducted disturbances, induced by RF-fields 10 Veff.

Programmable Parameters

Resolution: Defines the resolution per revolution (0 to 4 096).

Transmission Speed: Programmable from 10kbaud (1 000m) to 1 Mbaud (25 m) ; value per default : 20 Kbaud.

Address: Defines the software address of the encoder on the bus (1 to 127, Value per default : id = 1).

Direction: Defines the direction of count of the encoder.

RAX: Defines the value of the current position (with the shaft held stationary)

Games: High and low limits.

Communication Modes

Encoder configuration : Reading/Writing of the encoder objects dictionary (SDO mode).

3 modes are available to interrogate the encoder position/speed:

CYCLIC Mode: The sensor transmits its position in an asynchronous manner. The frequency of the transmission is defined by the programmable cyclic timer register from 0 to 65 535 ms,

SYNCHRO Mode: The Sensor transmits its position on a synchronous demand by the master.

POOLING Mode (Answer to a RTR signal) : The sensor only answers to a request.



DIMENSIONS

All Dimensions are in millimeters.

Shaft system with magnet to be ordered separately (see Accessories).

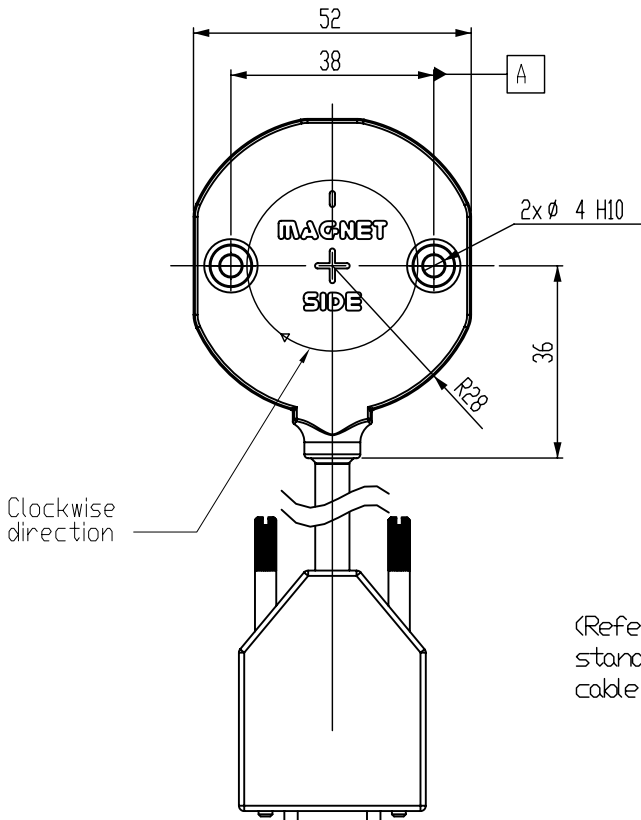

(Refer to the bus standards for max cable length)

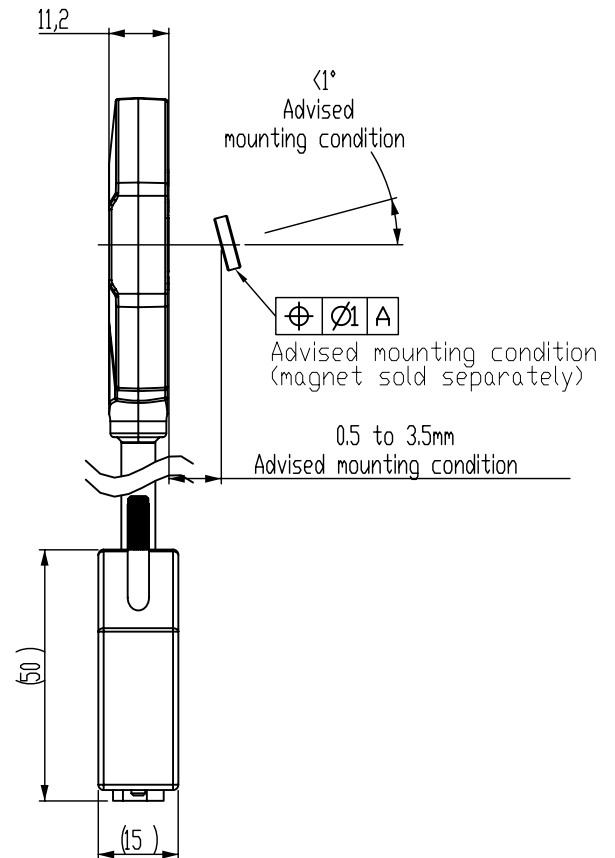

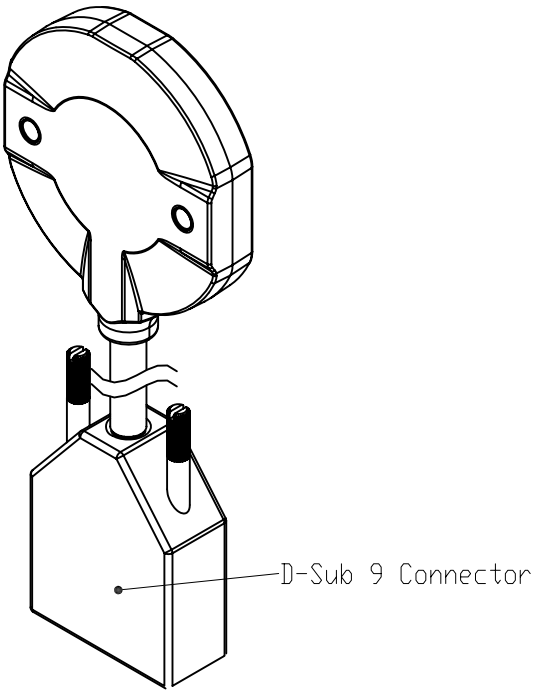

CANOPEN CONNECTION, CABLE + DB9 CONNECTOR

		N.C	CAN LOW	CAN GND / 0V	N.C.	N.C.	0V	CAN HIGH	N.C.	5/30Vdc	Ground
BB	PVC Cable + DB9	1	2	3	4	5	6	7	8	9	General Shielding

NOTES

Stray magnetic fields can interfere with accuracy and repeatability of the signal.



ORDERING OPTIONS

Example : ACW4_00//PBB//12//BBR020

(Contact the factory for special versions, ex : dimensions, connections...)

	ACW4	00	//	P	BB	B	//	12	//	BBR	020
Family	ACW4: Absolute Single-Turn Sensor										
Shaft Ø	00: Modular										
Supply	P: 5 to 30 Vdc										
Output Stage	BB: CANopen										
Code	B: Binary										
Resolution	12: 12 bits										
Connection	BBR: Side PVC cable with SUBDG connector										
Cable Length	020: 2 meters										



ACCESSORIES

Female magnet support + Magnet 8810/013

Ordering p/n : **M9105/Kxx**

KXX: Where XX is the shaft mounting diameter in mm. Standards are 06, 08, 10, 11, and 14 mm. i.e M9105/K10 mounts to a 10 mm shaft.

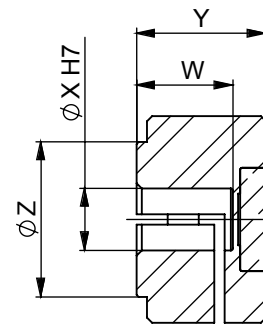
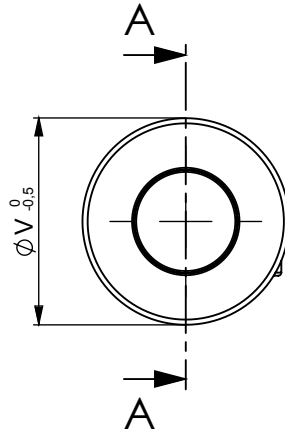
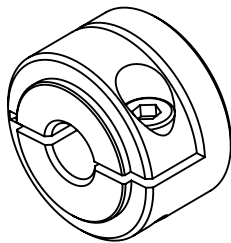

SECTION A-A

	M9105/K06	M9105/K08	M9105/K10	M9105/K11	M9105/K14
W	6 H7	8 H7	10 H7	11 H7	14 H7
X	20	20	26	26	29
Y	12,5	12,5	14	14	14
Z	15	15	15	15	18