

**SERIES:** ACZ09 | **DESCRIPTION:** MECHANICAL INCREMENTAL ENCODER

## ELECTRICAL SPECIFICATIONS

parameter	conditions/description	min	typ	max	units
output waveform	square wave				
output signals	A, B phase				
current consumption	10 mA				
output phase difference	T1, T2, T3, T4 ≥ 3.5 ms @ 60 rpm				
supply voltage	5 V dc max.				
output resolution	10, 15, 20 ppr				
switch rating	12 V dc, 50 mA (ACZ09BRXE models only)				
insulation resistance	100 MΩ, 300 V dc, 1 min.				
withstand voltage	300 V ac, 1 minute; no arc, damage or dielectric breakdown				

## MECHANICAL SPECIFICATIONS

parameter	conditions/description	min	typ	max	units
shaft load	axial			8	kgf
rotational torque	with detent click without detent click	60 60	140 80	220 100	gf·cm gf·cm
push switch operational force	(ACZ09BRXE models only)	300		1,500	gf·cm
push switch life	(ACZ09BRXE models only)			50,000	cycles
rotational life				30,000	cycles

## ENVIRONMENTAL SPECIFICATIONS

parameter	conditions/description	min	typ	max	units
operating temperature		-10		75	°C
storage temperature		-20		75	°C
humidity		0		95	% RH
vibration	0.75 mm max. travel for 2 hours	10		55	Hz

## PART NUMBER KEY

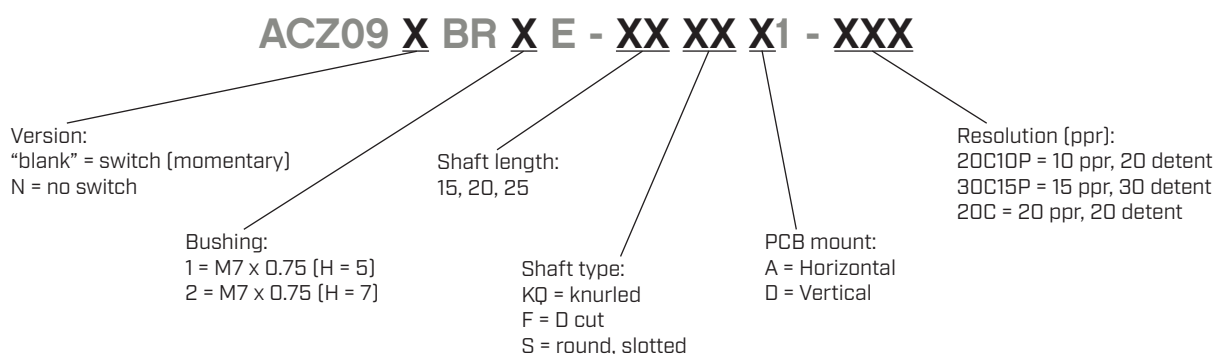

Replacement Hardware:  
M7x0.75 Nut: 071-0068R  
Washer: 071-0069R

## SHAFT OPTIONS (VERSIONS WITH SWITCH)

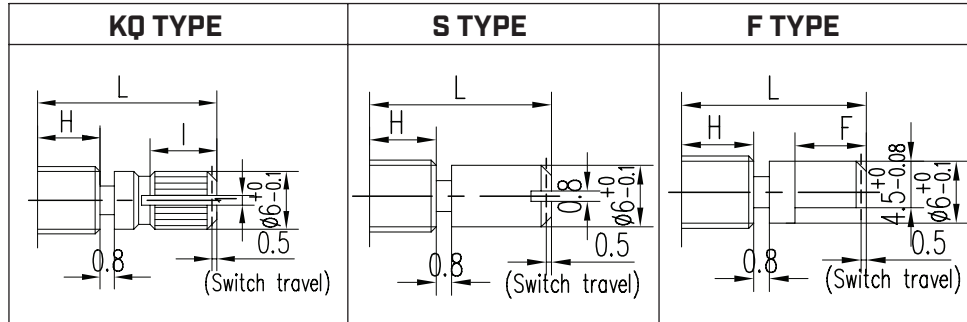

**H=5**

	15KQ	20KQ	25KQ
L	15	20	25
I	7	8.5	12

**H=5**

	15S	20S	25S
L	15	20	25

**H=5**

	15F	20F	25F
L	15	20	25
F	8	12	12

**H=7**

	15KQ	20KQ	25KQ
L	15	20	25
I	5	8.5	10

**H=7**

	15S	20S	25S
L	15	20	25

**H=7**

	15F	20F	25F
L	15	20	25
F	5	12	12

## SHAFT OPTIONS (VERSIONS WITHOUT SWITCH)

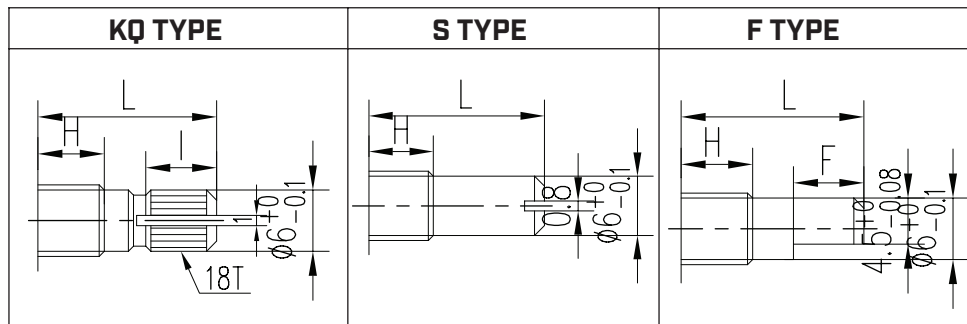

**H=5**

	15KQ	20KQ	25KQ
L	15	20	25
I	7	8.5	12

**H=5**

	15S	20S	25S
L	15	20	25

**H=5**

	15F	20F	25F
L	15	20	25
F	8	12	12

**H=7**

	15KQ	20KQ	25KQ
L	15	20	25
I	7	8.5	10

**H=7**

	15S	20S	25S
L	15	20	25

**H=7**

	15F	20F	25F
L	15	20	25
F	5	12	12

## MECHANICAL DRAWING (HORIZONTAL)

units: mm  
 tolerance:  
 $X \leq 10$ :  $\pm 0.3$  mm  
 $10 < X \leq 30$ :  $\pm 0.5$  mm  
 Unless otherwise noted

### ACZ09NBRXE

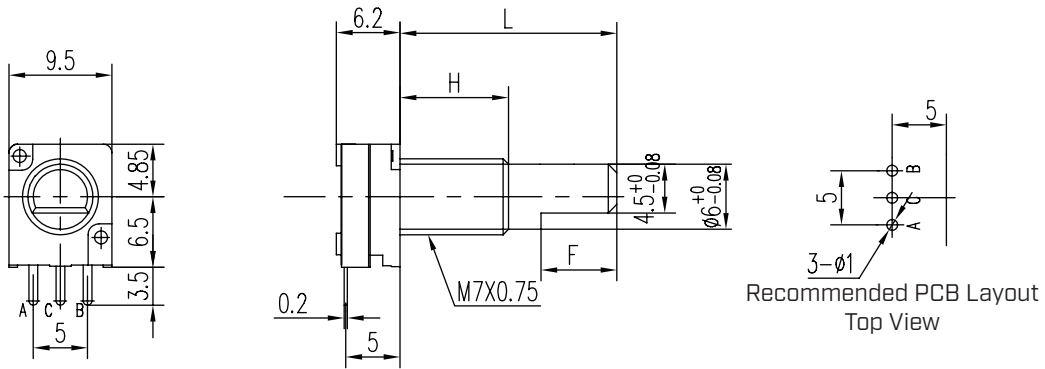

### ACZ09BRXE

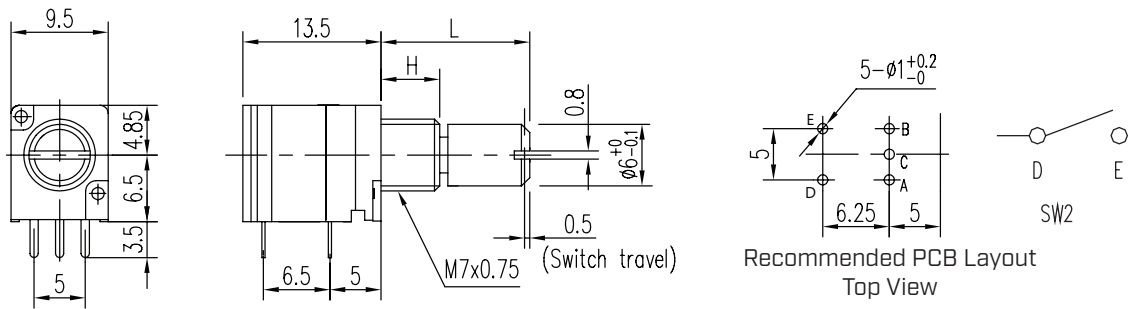

## MECHANICAL DRAWING (VERTICAL)

units: mm  
 tolerance:  
 $X \leq 10$ :  $\pm 0.3$  mm  
 $10 < X \leq 30$ :  $\pm 0.5$  mm  
 Unless otherwise noted

### ACZ09NBRXE

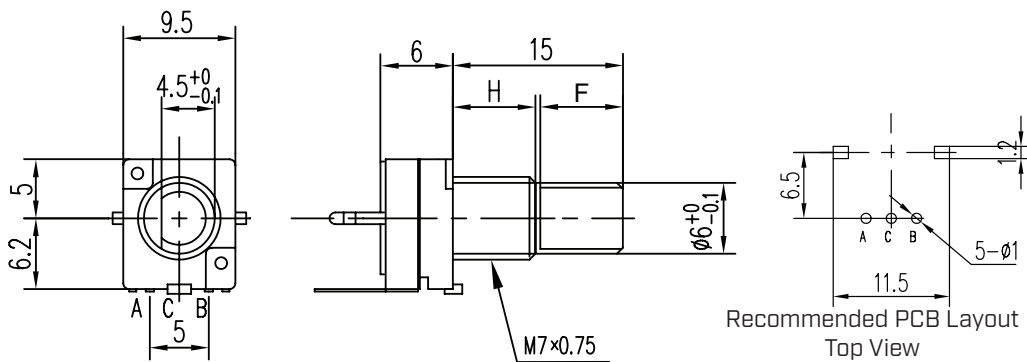

### ACZ09BRXE

