

**SERIES:** ACZ11 | **DESCRIPTION:** MECHANICAL INCREMENTAL ENCODER

## ELECTRICAL SPECIFICATIONS

parameter	conditions/description	min	typ	max	units
output waveform	square wave				
output signals	A, B phase				
current consumption	10 mA				
output phase difference	T1, T2, T3, T4 $\geq$ 3.5 ms @ 60 rpm (see output waveform)				
supply voltage	5 V dc max.				
output resolution	12, 15, 20, 30 ppr				
switch rating	12 V dc, 50 mA (ACZ11BRXE models only)				
insulation resistance	300 V dc, 100 M $\Omega$				
withstand voltage	300 V ac				

## MECHANICAL SPECIFICATIONS

parameter	conditions/description	min	typ	max	units
shaft load	axial			8	kgf
rotational torque	with detent click without detent click	60 60	140 80	220 100	gf·cm gf·cm
push switch operational force	(ACZ11BRXE models only)	300		900	gf·cm
push switch life	(ACZ11BRXE models only)			50,000	cycles
rotational life				30,000	cycles

## ENVIRONMENTAL SPECIFICATIONS

parameter	conditions/description	min	typ	max	units
operating temperature		-10		65	$^{\circ}$ C
storage temperature		-40		75	$^{\circ}$ C
humidity		85			% RH
vibration	0.75 mm max. travel for 2 hours	10		55	Hz

## PART NUMBER KEY

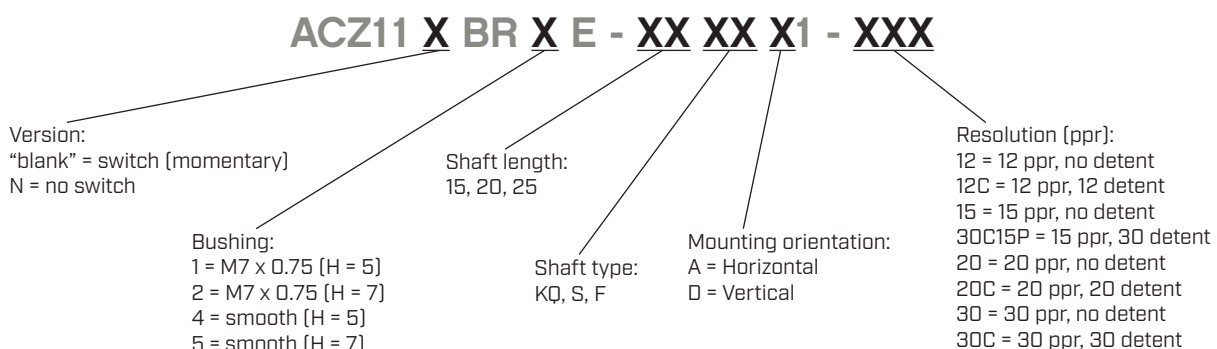

Replacement Hardware:  
M7x0.75 Nut: 071-0068R  
Washer: 071-0069R

## SHAFT OPTIONS (VERSIONS WITH SWITCH)

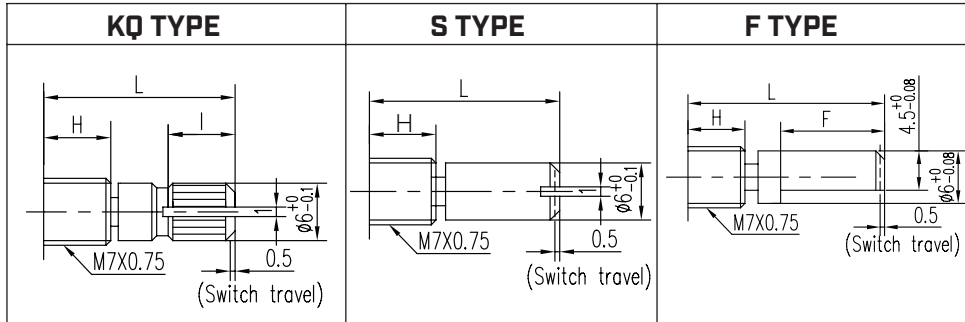

**H=5**

	15KQ	20KQ	25KQ
L	15	20	25
I	6	8.5	12

**H=5**

	15S	20S	25S
L	15	20	25

**H=5**

	15F	20F	25F
L	15	20	25
F	8	10	12

**H=7**

	15KQ	20KQ	25KQ
L	15	20	25
I	5	8.5	10

**H=7**

	15S	20S	25S
L	15	20	25

**H=7**

	15F	20F	25F
L	15	20	25
F	8	10	12

## SHAFT OPTIONS (VERSIONS WITHOUT SWITCH)

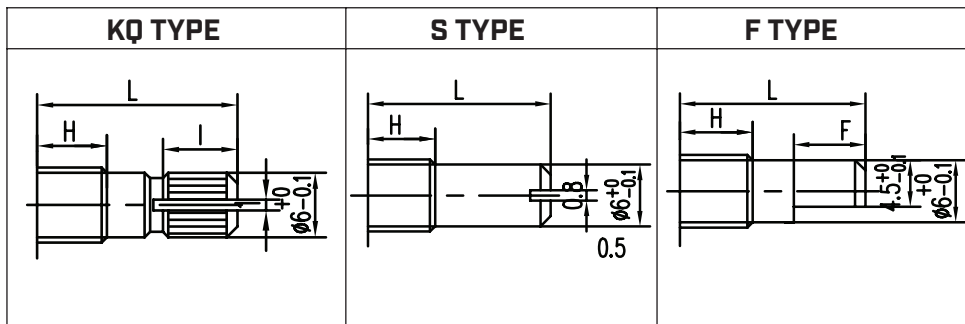

**H=5**

	15KQ	20KQ	25KQ
L	15	20	25
I	7	10	12

**H=5**

	15S	20S	25S
L	15	20	25

**H=5**

	15F	20F	25F
L	15	20	25
F	8	10	12

**H=7**

	15KQ	20KQ	25KQ
L	15	20	25
I	5	10	10

**H=7**

	15S	20S	25S
L	15	20	25

**H=7**

	15F	20F	25F
L	15	20	25
F	8	10	12

## OUTPUT WAVEFORM

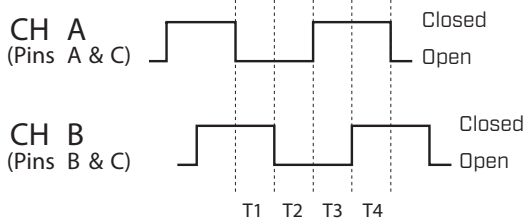

CW direction (@ 60 rpm)

## DETENT POSITIONS

Model 12C & 20C

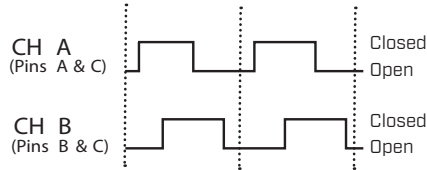

CW direction →

Model 15P30C

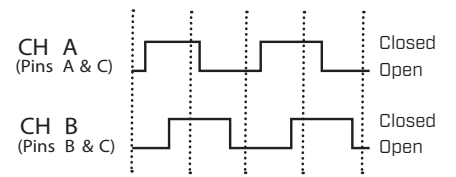

CW direction →

## SLIDING NOISE

$t =$  Masking time to avoid chatter (5mS)  $V_1 = V_2 = 1V$  max.

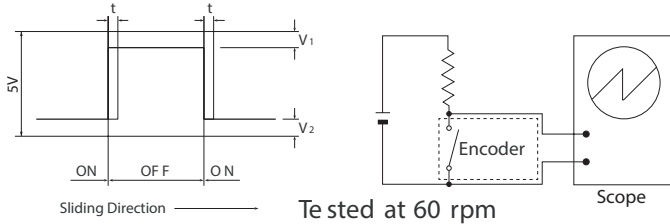

## SUGGESTED FILTER

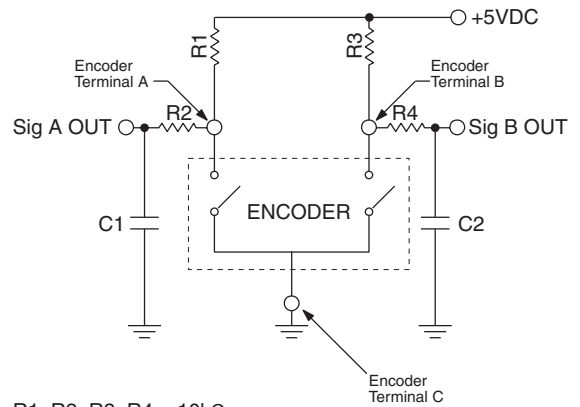

R1, R2, R3, R4 = 10kΩ  
C1, C2 = 0.01μF

## MECHANICAL DRAWING (HORIZONTAL)

units: mm  
 tolerance:  
 $X \leq 10$ :  $\pm 0.3$  mm  
 $10 < X \leq 30$ :  $\pm 0.5$  mm  
 Unless otherwise noted

### ACZ11NBRXE

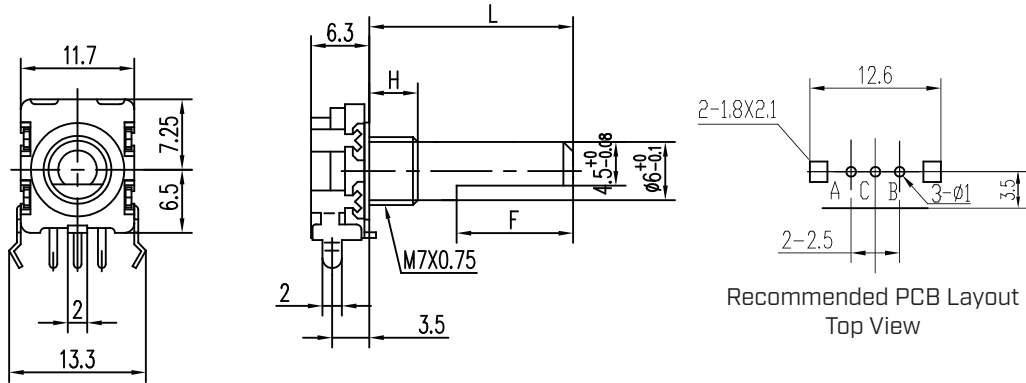

### ACZ11BRXE

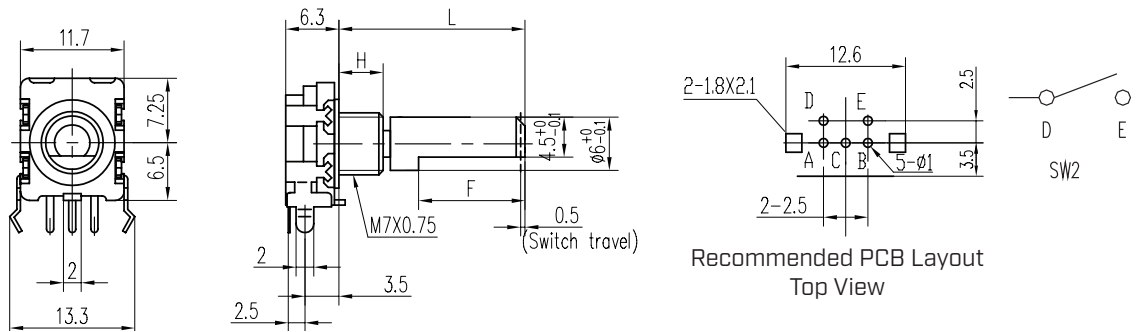

## MECHANICAL DRAWING (VERTICAL)

units: mm  
 tolerance:  
 $X \leq 10$ :  $\pm 0.3$  mm  
 $10 < X \leq 30$ :  $\pm 0.5$  mm  
 Unless otherwise noted

### ACZ11NBRXE

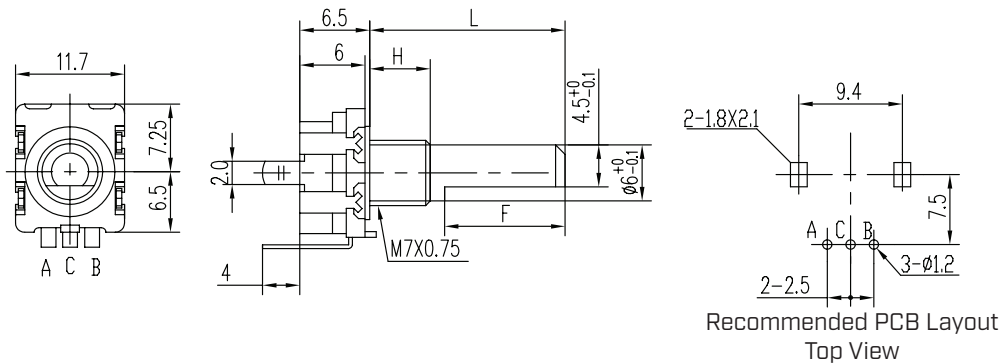

### ACZ11BRXE

