

ACZRW5225B-HF Thru. ACZRW5256B-HF

Voltage: 3.0 to 30 Volts

Power: 350 mW

RoHS Device

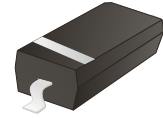

Features

- Planar die construction.
- Ultra-small surface mount package.
- General purpose, medium current.
- Ideally suited for automated assembly processes.
- AEC-Q101 Qualified.

Mechanical data

- Case: SOD-123, molded plastic.
- Polarity: indicated by cathode band.
- Mounting position: Any.

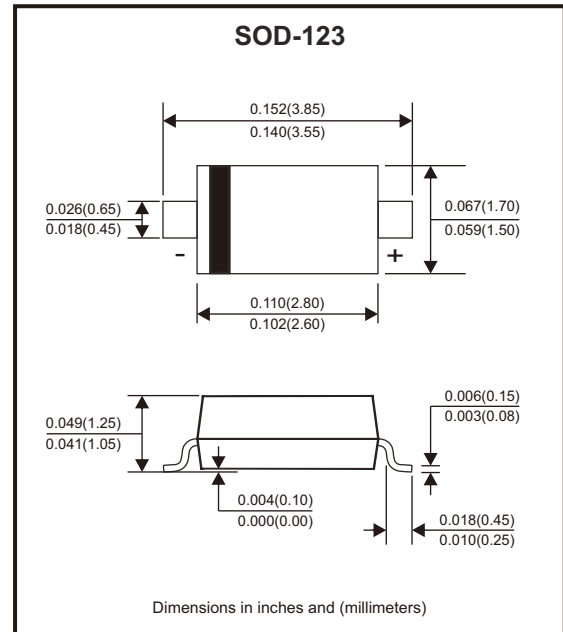

Circuit Diagram



Maximum Rating (@Ta=25°C unless otherwise specified)

Parameter	Symbol	Value	Unit
Forward voltage (Note 2) @ I _F = 10mA	V _F	0.9	V
Power dissipation (Note 1)	P _D	350	mW
Thermal resistance, junction to ambient air	R _{θJA}	357	°C/W
Operation junction and storage temperature range	T _J , T _{STG}	-55 to +150	°C

Notes: 1. Device mounted on ceramic PCB; 7.6mm x 9.4mm x 0.87mm with pad areas 25mm².

2. Tested with pulses, T_p ≤ 1.0ms.

Electrical Characteristics (@Ta = 25°C unless otherwise specified)

Part Number	Zener voltage range			Maximum zener impedance			Maximum reverse current		Marking code	
	Vz@IzT			IzT	ZzT@IzT	Zzk@Izk	IzK	Ir		Vr
	Min(V)	Nom(V)	Max(V)	(mA)	(Ω)	(Ω)	(mA)	(μA)		(V)
ACZRW5225B-HF	2.85	3.0	3.15	20	30	1600	0.25	50	1.0	C5
ACZRW5226B-HF	3.14	3.3	3.47	20	28	1600	0.25	25	1.0	G1
ACZRW5227B-HF	3.42	3.6	3.78	20	24	1700	0.25	15	1.0	G2
ACZRW5228B-HF	3.71	3.9	4.10	20	23	1900	0.25	10	1.0	G3
ACZRW5229B-HF	4.09	4.3	4.52	20	22	2000	0.25	5	1.0	G4
ACZRW5230B-HF	4.47	4.7	4.94	20	19	1900	0.25	5	2.0	G5
ACZRW5231B-HF	4.85	5.1	5.36	20	17	1600	0.25	5	2.0	E1
ACZRW5232B-HF	5.32	5.6	5.88	20	11	1600	0.25	5	3.0	E2
ACZRW5233B-HF	5.70	6.0	6.30	20	7	1600	0.25	5	3.5	E3
ACZRW5234B-HF	5.89	6.2	6.51	20	7	1000	0.25	5	4.0	E4
ACZRW5235B-HF	6.46	6.8	7.14	20	5	750	0.25	3	5.0	E5
ACZRW5236B-HF	7.13	7.5	7.88	20	6	500	0.25	3	6.0	F1
ACZRW5237B-HF	7.79	8.2	8.61	20	8	500	0.25	3	6.5	F2
ACZRW5238B-HF	8.27	8.7	9.14	20	8	600	0.25	3	6.5	F3
ACZRW5239B-HF	8.65	9.1	9.56	20	10	600	0.25	3	7.0	F4
ACZRW5240B-HF	9.50	10	10.50	20	17	600	0.25	3	8.0	F5
ACZRW5241B-HF	10.45	11	11.55	20	22	600	0.25	2	8.4	H1
ACZRW5242B-HF	11.40	12	12.60	20	30	600	0.25	1	9.1	H2
ACZRW5243B-HF	12.35	13	13.65	9.5	13	600	0.25	0.5	9.9	H3
ACZRW5244B-HF	13.30	14	14.70	9.0	15	600	0.25	0.1	10	H4
ACZRW5245B-HF	14.25	15	15.75	8.5	16	600	0.25	0.1	11	H5
ACZRW5246B-HF	15.20	16	16.80	7.8	17	600	0.25	0.1	12	J1
ACZRW5248B-HF	17.10	18	18.90	7.0	21	600	0.25	0.1	14	J3
ACZRW5250B-HF	19.00	20	21.00	6.2	25	600	0.25	0.1	15	J5
ACZRW5251B-HF	20.90	22	23.10	5.6	29	600	0.25	0.1	17	K1
ACZRW5252B-HF	22.80	24	25.20	5.2	33	600	0.25	0.1	18	K2
ACZRW5253B-HF	23.75	25	26.25	5.0	35	600	0.25	0.1	19	K3
ACZRW5254B-HF	25.65	27	28.35	5.0	41	600	0.25	0.1	21	K4
ACZRW5255B-HF	26.60	28	29.40	4.5	44	600	0.25	0.1	21	K5
ACZRW5256B-HF	28.50	30	31.50	4.2	49	600	0.25	0.1	23	M1

Rating and Characteristic Curves (ACZRW52xxB-HF Series)

Fig.1 - Zener Characteristics

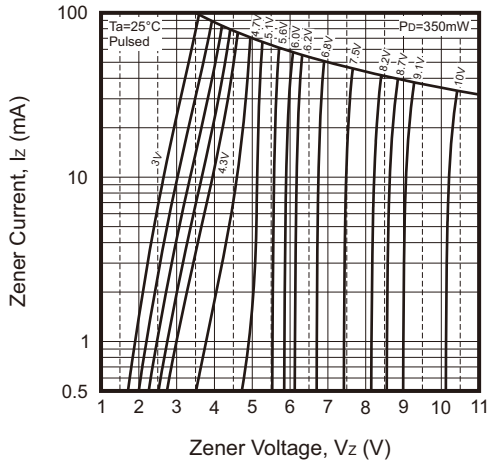

Fig.2 - Zener Characteristics

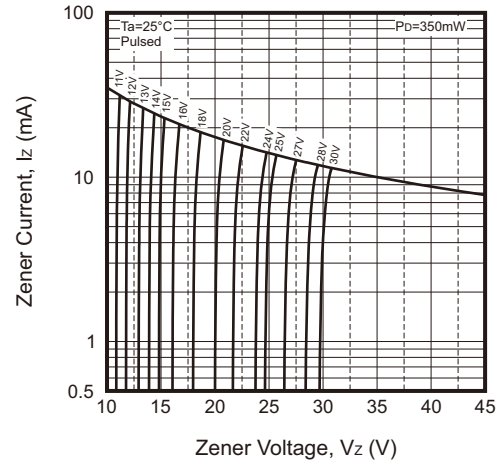

Fig.3 - Temperature Coefficients

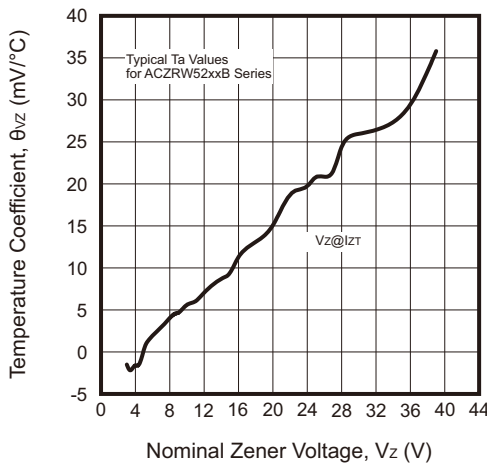

Fig.4 - Typical Leakage Current

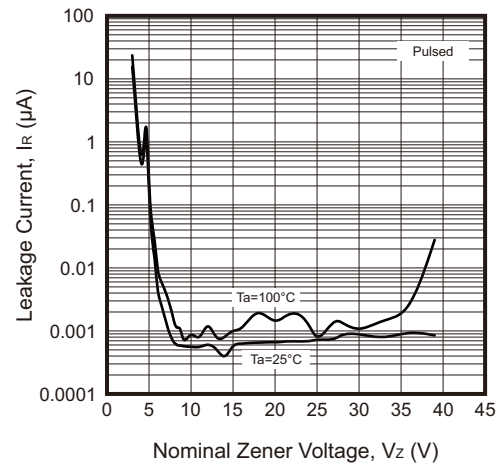

Fig.5 - Typical Capacitance

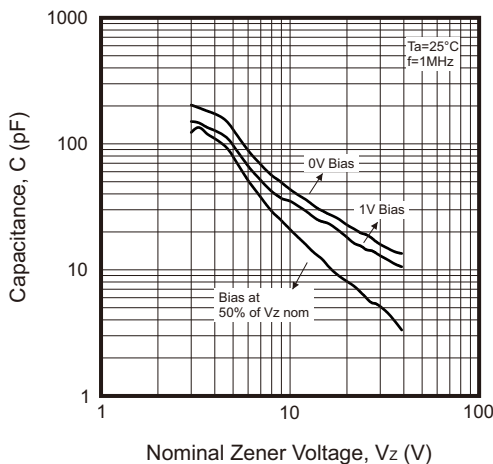
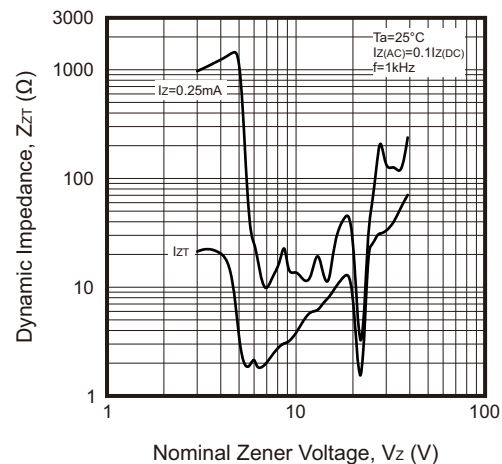
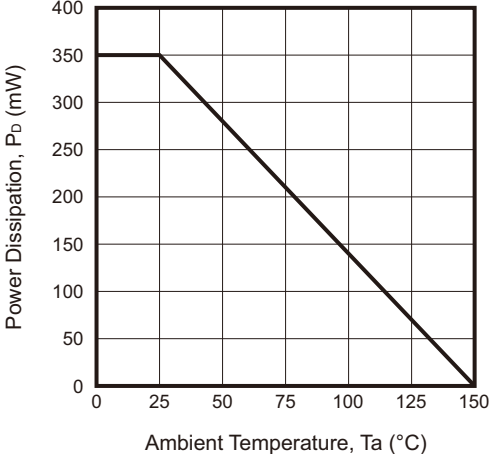

Fig.6 - Effect of Zener Voltage on Zener Impedance



Rating and Characteristic Curves (ACZRW52xxB-HF Series)

Fig.7 - Power Derating Curve



Reel Taping Specification

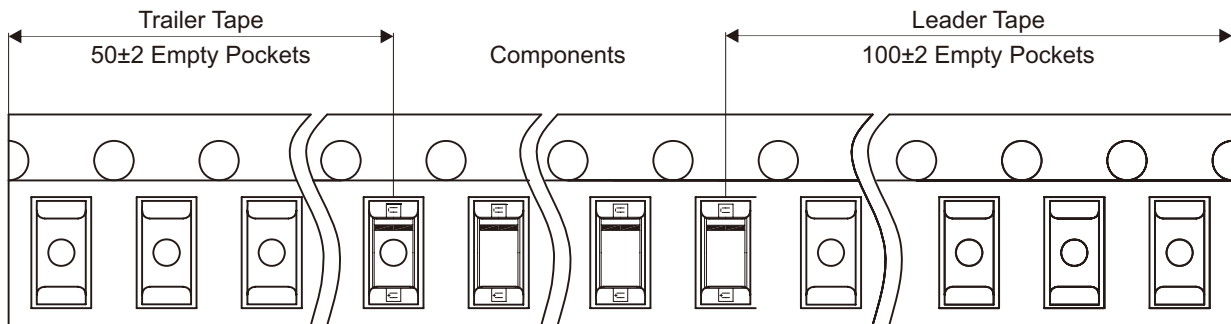
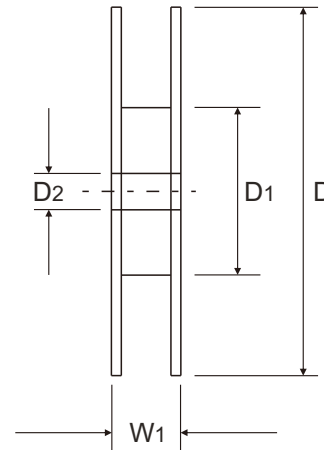
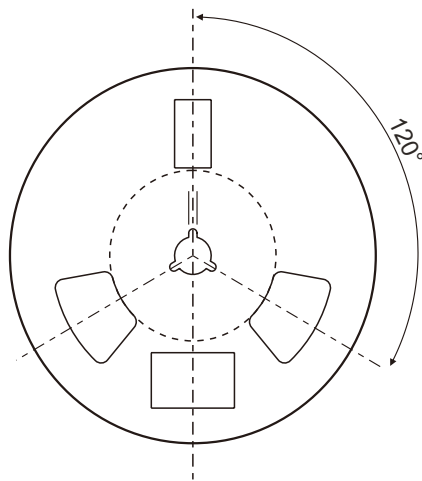
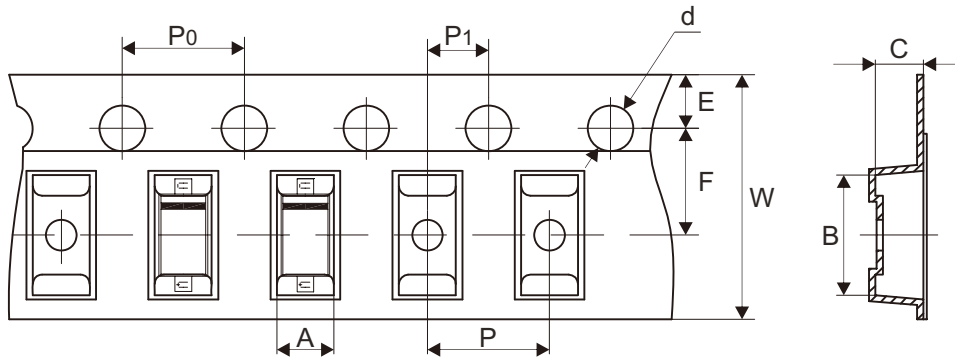

SOD-123	SYMBOL	A	B	C	d	D	D1	D2
	(mm)	1.85 ± 0.10	3.95 ± 0.10	1.57 ± 0.10	1.55 ± 0.10	178.00 ± 1.00	54.40 ± 0.40	13.00 ± 0.20
	(inch)	0.073 ± 0.004	0.156 ± 0.004	0.062 ± 0.004	0.061 ± 0.004	7.008 ± 0.039	2.142 ± 0.016	0.512 ± 0.008

SOD-123	SYMBOL	E	F	P	P1	P0	W	W1
	(mm)	1.75 ± 0.10	3.50 ± 0.05	4.00 ± 0.10	2.00 ± 0.10	4.00 ± 0.10	8.00 ± 1.00	12.30 ± 1.00
	(inch)	0.069 ± 0.004	0.138 ± 0.002	0.157 ± 0.004	0.079 ± 0.004	0.157 ± 0.004	0.315 ± 0.039	0.484 ± 0.039