

NOTES:

1. MATERIALS OF CONSTRUCTION:

- SMA BODY - STAINLESS STEEL, PASSIVATED
- P-SMP BODY - STAINLESS STEEL, PASSIVATED
- CONTACT PIN - BERYLLIUM COPPER, GOLD PLATING
- INSULATOR - PTFE, NATURAL

2. ELECTRICAL:

- A. IMPEDANCE: 50 OHM, NOMINAL
- B. FREQUENCY RANGE: DC - 10 GHz
- C. RETURN LOSS(VSWR): 33 dB MIN. @ DC-4 GHz
26 dB MIN. @ 4-10 GHz
- D. INSERTION LOSS: 0.05X $\sqrt{f(\text{GHz})}$ dB MAX.
- E. POWER HANDLING: 200W MAX. @ 2.2 GHz AT 20°C
- F. D.W.V: 1000 VRMS, MIN.

3. MECHANICAL:

- A. DURABILITY: SMA JACK SIDE : 500 CYCLES MIN.
P-SMP PLUG SIDE: 100 CYCLES MIN
- B. TEMPERATURE RANGE: -55°C TO +155°C

4. PACKAGING:

- A. QUANTITY: SINGLE PACK
- B. MARKING: BAG TO BE MARKED
"AMPHENOL RF, AD-SMAJ-PSMPP-2, AND DATE CODE"

THIRD ANGLE PROJ.

REVISIONS

REV	DESCRIPTION	DATE	ECO	APPR
A	RELEASE TO MFG.	15-May-18	08102	BEW

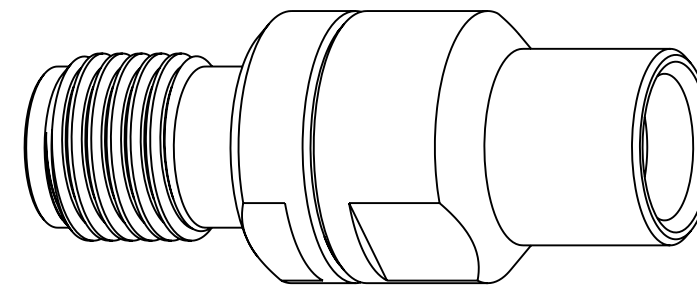

SCALE 4.000

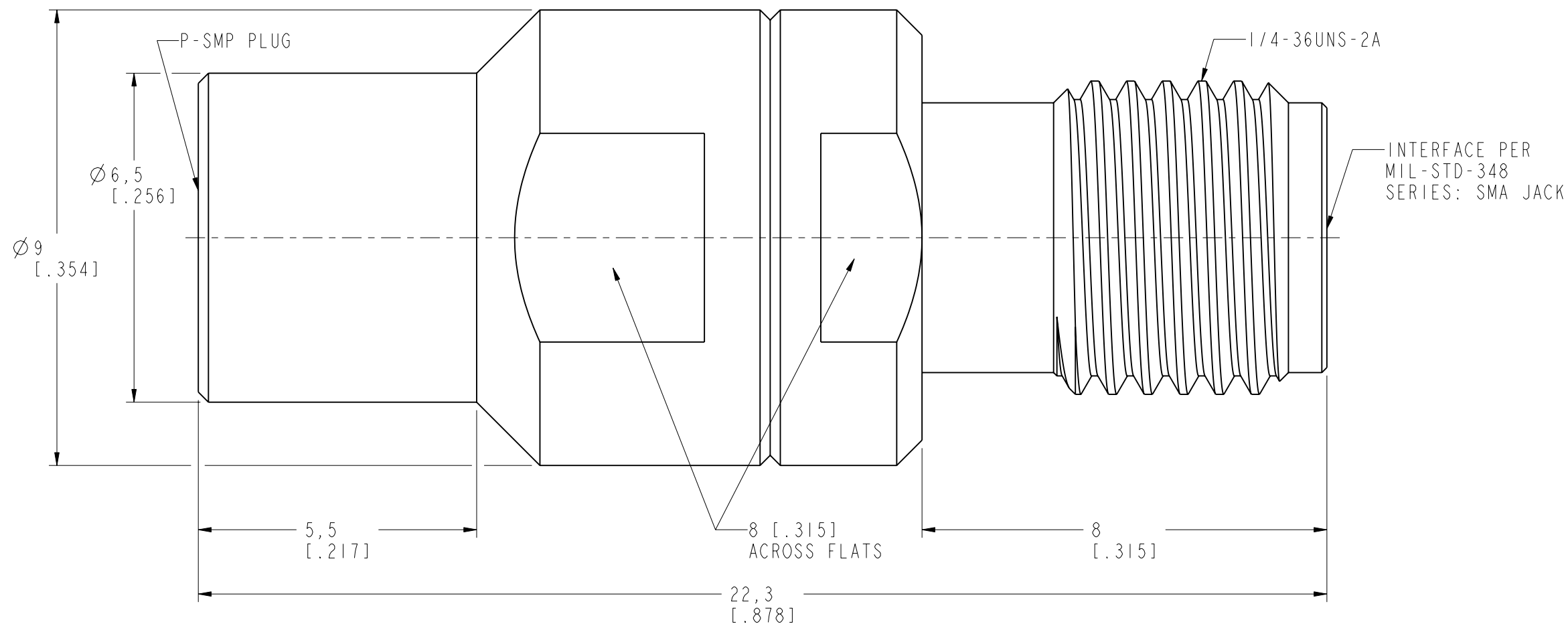

CUSTOMER OUTLINE DRAWING

ALL OTHER SHEETS ARE FOR INTERNAL USE ONLY

<p>UNLESS OTHERWISE SPECIFIED, DIMENSIONS ARE IN METRIC AND TOLERANCES ARE: < 0.5mm ± 0.05mm 0.5 - 6mm ± 0.1mm 6 - 30mm ± 0.2mm 30 - 120mm ± 0.3mm ANGLES ± 1°</p>	MATERIAL	DRAWN M. ZHANG	DATE 15-May-18	<p>TITLE P-SMP PLUG (LIMITED DETENT) TO SMA JACK ADAPTER</p>	<p>Amphenol RF www.amphenolrf.com</p>
	REFERENCE EAR# 6971 AND	ENGINEER M. ZHANG	DATE 08-Apr-16		
<p>NOTICE - These drawings, specifications, or other data (1) are, and remain the property of Amphenol corp. (2) must be returned upon request; and (3) are confidential and not to be disclosed to any person other than those to whom they are given by Amphenol Corp. the furnishing of these drawings, specifications, or other data by Amphenol Corp., or to any other person to anyone for any purpose is not to be regarded by implication or otherwise in any manner licensing, granting rights to permitting such holder or any other person to manufacture, use or sell any product, process or design, patented or otherwise, that may in any way be related to or disclosed by said drawings, specifications, or other data.</p>	CONFIGURATION LEVEL: In Work	APPROVED S. HSIEH	DATE 17-May-18	SCALE: 10.0:1.0 SHEET 2 OF 2	ITEM NO. AD-SMAJ-PSMPP-2
	FINISH	CAD FILE	DWG SIZE B	REV A	PART NO. AD-SMAJ-PSMPP-2