

NOTES:

1. MATERIALS AND FINISHES:
  - BODY - BRASS, GOLD PLATING
  - COVER - BRASS, NICKEL PLATING
  - CONTACT - BRASS, GOLD PLATING
  - CONTACT PIN - BeCu, GOLD PLATING
  - INSULATORS - PTFE, NATURAL
  - COUPLING NUTS - STAINLESS STEEL, PASSIVATED
2. ELECTRICAL:
  - A. IMPEDANCE: 50 OHM
  - B. FREQUENCY RANGE: DC-22 GHz
  - C. VSWR: 1.30 MAX.
  - D. DIELECTRIC WITHSTANDING VOLTAGE: 1000 VRMS. MIN.
3. MECHANICAL:
  - A. DURABILITY: 500 CYCLES MIN.
  - B. TEMPERATURE RANGE: -65°C TO 165°C
4. PACKAGING:
  - A. QUANTITY: SINGLE PACK
  - B. MARKING: PACKAGING TO BE MARKED "AMPHENOL RF, AD-SMAPSMAP-2, DATE CODE"

REVISIONS				
REV	DESCRIPTION	DATE	ECN	APPR
A	RELEASE TO MANUFACTURING	07-JUL-20	15233	SH
B	VSWR REVISED TO 1.30 MAX CAP UPDATED	01-DEC-20	15399	SH
C	CAP UPDATE, ADD STAKING	20-SEP-21	15915	WZ

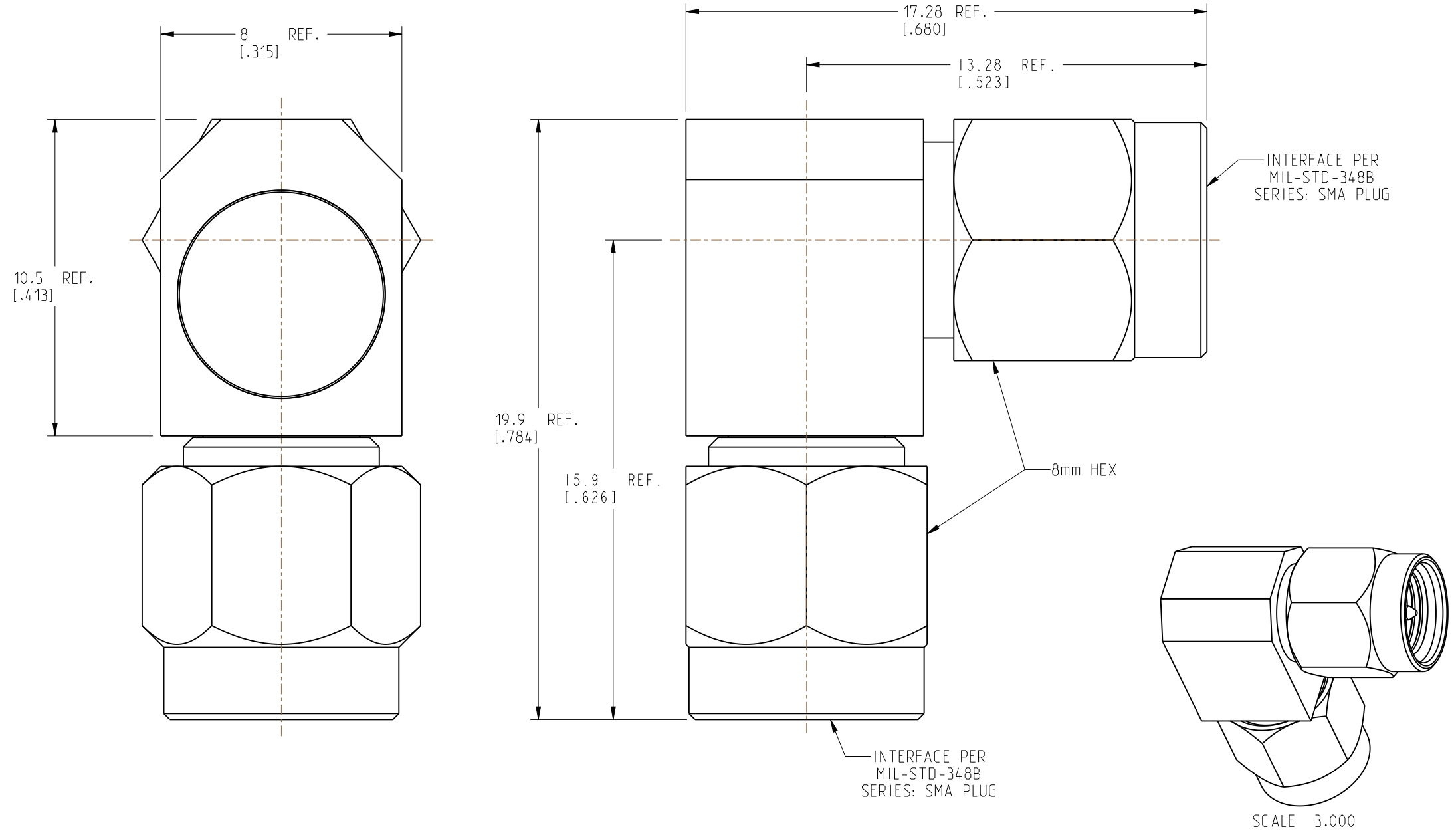

**CUSTOMER OUTLINE DRAWING**

ALL OTHER SHEETS ARE FOR INTERNAL USE ONLY

NOTICE: These drawings, specifications, or other data (1) are, and remain the property of Amphenol corp. (2) must be returned upon request; and (3) are confidential and not to be disclosed to any person other than those to whom they are given by Amphenol Corp. The furnishing of these drawings, specifications, or other data by Amphenol Corp., or to any other person to anyone for any purpose is not to be regarded by implication or otherwise in any manner licensing, granting rights to permitting such holder or any other person to manufacture, use or sell any product, process or design, patented or otherwise, that may in any way be related to or disclosed by said drawings, specifications, or other data.

UNLESS OTHERWISE SPECIFIED  
DIMENSIONS ARE METRIC (INCHES) AND TOLERANCES ARE:

<0.5mm = ±0.05mm	[<0.020 = ±0.002]
>0.5 - 6mm = ±0.1mm	[>0.020 - 0.236 = ±0.004]
>6.00 - 30mm = ±0.2mm	[>0.236 - 1.181 = ±0.008]
>30.00 - 120mm = ±0.3mm	[>1.181 - 4.725 = ±0.012]

ANGLES = ±1°

MATERIAL  
SEE NOTES

TITLE  
HIGH PERFORMANCE  
R/A SMA PLUG - SMA  
PLUG ADAPTER

Amphenol RF

THIRD ANGLE PROJ. REFERENCE 901-10656 EAR# 8845

ENGR.1 C.VIGORITO ENGR.2 WIKI DATE 20-SEP-21

SHEET NO. 2 OF 2 SCALE: 6.0:1.0

SIZE B	DRAWING NO. AD-SMAPSMAP-2	REV C
	ITEM NO. AD-SMAPSMAP-2	
	PART NO. AD-SMAPSMAP-2	