

FEATURES

- 4-quadrant multiplication**
- Low cost, 8-lead SOIC and PDIP packages**
- Complete—no external components required**
- Laser-trimmed accuracy and stability**
- Total error within 2% of full scale**
- Differential high impedance X and Y inputs**
- High impedance unity-gain summing input**
- Laser-trimmed 10 V scaling reference**

APPLICATIONS

- Multiplication, division, squaring**
- Modulation/demodulation, phase detection**
- Voltage-controlled amplifiers/attenuators/filters**

GENERAL DESCRIPTION

The **AD633** is a functionally complete, four-quadrant, analog multiplier. It includes high impedance, differential X and Y inputs, and a high impedance summing input (Z). The low impedance output voltage is a nominal 10 V full scale provided by a buried Zener. The **AD633** is the first product to offer these features in modestly priced 8-lead PDIP and SOIC packages.

The **AD633** is laser calibrated to a guaranteed total accuracy of 2% of full scale. Nonlinearity for the Y input is typically less than 0.1% and noise referred to the output is typically less than 100 μV rms in a 10 Hz to 10 kHz bandwidth. A 1 MHz bandwidth, 20 V/ μs slew rate, and the ability to drive capacitive loads make the **AD633** useful in a wide variety of applications where simplicity and cost are key concerns.

The versatility of the **AD633** is not compromised by its simplicity. The Z input provides access to the output buffer amplifier, enabling the user to sum the outputs of two or more multipliers, increase the multiplier gain, convert the output voltage to a current, and configure a variety of applications. For further information, see the [Multiplier Application Guide](#).

FUNCTIONAL BLOCK DIAGRAM

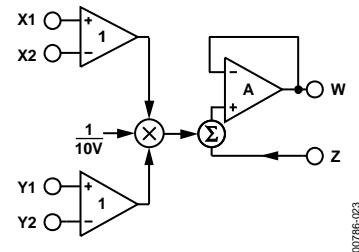

Figure 1.

The **AD633** is available in 8-lead PDIP and SOIC packages. It is specified to operate over the 0°C to 70°C commercial temperature range (J Grade) or the -40°C to +85°C industrial temperature range (A Grade).

PRODUCT HIGHLIGHTS

1. The **AD633** is a complete four-quadrant multiplier offered in low cost 8-lead SOIC and PDIP packages. The result is a product that is cost effective and easy to apply.
2. No external components or expensive user calibration are required to apply the **AD633**.
3. Monolithic construction and laser calibration make the device stable and reliable.
4. High (10 M Ω) input resistances make signal source loading negligible.
5. Power supply voltages can range from ± 8 V to ± 18 V. The internal scaling voltage is generated by a stable Zener diode; multiplier accuracy is essentially supply insensitive.

TABLE OF CONTENTS

| | |
|--|---|
| Features | 1 |
| Applications..... | 1 |
| Functional Block Diagram | 1 |
| General Description | 1 |
| Product Highlights | 1 |
| Revision History | 2 |
| Specifications..... | 3 |
| Absolute Maximum Ratings..... | 4 |
| Thermal Resistance | 4 |
| ESD Caution..... | 4 |
| Pin Configurations and Function Descriptions | 5 |
| Typical Performance Characteristics | 6 |
| Functional Description | 8 |
| Error Sources..... | 8 |
| Applications Information | 9 |
| Multiplier Connections | 9 |

REVISION HISTORY

3/15—Rev. J to Rev. K

| | |
|---|----|
| Changes to General Description Section | 1 |
| Changes to Figure 12 Caption and Figure 14 Caption | 9 |
| Added Model Results Section, Examples of DC, Sin, and Pulse Solutions Using Multisim Section, and Figure 24 Through Figure 29, Renumbered Sequentially..... | 13 |
| Added Examples of DC, Sin, and Pulse Solutions Using PSpice Section, Examples of DC, Sin, and Pulse Solutions Using SIMetrix Section, and Figure 30 Through Figure 37 | 14 |
| Added Figure 38 Through Figure 41 | 15 |

9/13—Rev. I to Rev. J

| | |
|--|-----------|
| Reorganized Layout..... | Universal |
| Change to Table 1 | 3 |
| Changes to Figure 4..... | 6 |
| Added Figure 10, Renumbered Sequentially | 7 |
| Changes to Figure 15..... | 9 |
| Changes to Figure 20..... | 10 |
| Changes to Figure 31 | 14 |
| Added Figure 32..... | 15 |

2/12—Rev. H to Rev. I

| | |
|--|---|
| Changes to Figure 1 | 1 |
| Changes to Figure 2..... | 5 |
| Changes to Generating Inverse Functions Section | 8 |
| Changes to Figure 15..... | 9 |
| Added Evaluation Board Section and Figure 23 to Figure 29, | |

| | |
|--|----|
| Squaring and Frequency Doubling..... | 9 |
| Generating Inverse Functions | 9 |
| Variable Scale Factor | 10 |
| Current Output..... | 10 |
| Linear Amplitude Modulator | 10 |
| Voltage-Controlled, Low-Pass and High-Pass Filters..... | 10 |
| Voltage-Controlled Quadrature Oscillator..... | 11 |
| Automatic Gain Control (AGC) Amplifiers | 11 |
| Model Results..... | 13 |
| Examples of DC, Sin, and Pulse Solutions Using Multisim.. | 13 |
| Examples of DC, Sin, and Pulse Solutions Using PSpice.... | 14 |
| Examples of DC, Sin, and Pulse Solutions Using SIMetrix .. | 14 |
| Evaluation Board | 16 |
| Outline Dimensions | 19 |
| Ordering Guide | 20 |

| | |
|---------------------------------|----|
| Renumbered Sequentially | 12 |
| Changes to Ordering Guide | 15 |

4/11—Rev. G to Rev. H

| | |
|--|---|
| Changes to Figure 1, Deleted Figure 2..... | 1 |
| Added Figure 2, Figure 3, Table 4, Table 5 | 5 |
| Deleted Figure 9, Renumbered Subsequent Figures..... | 6 |
| Changes to Figure 15..... | 9 |

4/10—Rev. F to Rev. G

| | |
|--|---|
| Changes to Equation 1 | 6 |
| Changes to Equation 5 and Figure 14..... | 7 |
| Changes to Figure 21..... | 9 |

10/09—Rev. E to Rev. F

| | |
|---------------------------------|-----------|
| Changes to Format | Universal |
| Changes to Figure 21..... | 9 |
| Updated Outline Dimensions..... | 11 |
| Changes to Ordering Guide | 12 |

10/02—Rev. D to Rev. E

| | |
|--|---|
| Edits to Title of 8-Lead Plastic SOIC Package (RN-8) | 1 |
| Edits to Ordering Guide | 2 |
| Change to Figure 13 | 7 |
| Updated Outline Dimensions..... | 8 |

SPECIFICATIONS

$T_A = 25^\circ\text{C}$, $V_S = \pm 15\text{ V}$, $R_L \geq 2\text{ k}\Omega$.

Table 1.

| Parameter | Conditions | AD633J, AD633A | | | Unit |
|--------------------------------------|--|--|--------------|-------------|--------------------------------|
| | | Min | Typ | Max | |
| TRANSFER FUNCTION | | $W = \frac{(X1 - X2)(Y1 - Y2)}{10\text{ V}} + Z$ | | | |
| MULTIPLIER PERFORMANCE | | | | | |
| Total Error | $-10\text{ V} \leq X, Y \leq +10\text{ V}$ | | ± 1 | $\pm 2^1$ | % full scale |
| T_{MIN} to T_{MAX} | | | ± 3 | | % full scale |
| Scale Voltage Error | SF = 10.00 V nominal | | $\pm 0.25\%$ | | % full scale |
| Supply Rejection | $V_S = \pm 14\text{ V}$ to $\pm 16\text{ V}$ | | ± 0.01 | | % full scale |
| Nonlinearity, X | $X = \pm 10\text{ V}$, $Y = +10\text{ V}$ | | ± 0.4 | $\pm 1^1$ | % full scale |
| Nonlinearity, Y | $Y = \pm 10\text{ V}$, $X = +10\text{ V}$ | | ± 0.1 | $\pm 0.4^1$ | % full scale |
| X Feedthrough | Y nulled, $X = \pm 10\text{ V}$ | | ± 0.3 | $\pm 1^1$ | % full scale |
| Y Feedthrough | X nulled, $Y = \pm 10\text{ V}$ | | ± 0.1 | $\pm 0.4^1$ | % full scale |
| Output Offset Voltage ² | | | ± 5 | $\pm 50^1$ | mV |
| DYNAMICS | | | | | |
| Small Signal Bandwidth | $V_O = 0.1\text{ V rms}$ | | 1 | | MHz |
| Slew Rate | $V_O = 20\text{ V p-p}$ | | 20 | | V/ μs |
| Settling Time to 1% | $\Delta V_O = 20\text{ V}$ | | 2 | | μs |
| OUTPUT NOISE | | | | | |
| Spectral Density | | | 0.8 | | $\mu\text{V}/\sqrt{\text{Hz}}$ |
| Wideband Noise | $f = 10\text{ Hz}$ to 5 MHz | | 1 | | mV rms |
| | $f = 10\text{ Hz}$ to 10 kHz | | 90 | | $\mu\text{V rms}$ |
| OUTPUT | | | | | |
| Output Voltage Swing | | $\pm 11^1$ | | | V |
| Short Circuit Current | $R_L = 0\ \Omega$ | | 30 | 40^1 | mA |
| INPUT AMPLIFIERS | | | | | |
| Signal Voltage Range | Differential | $\pm 10^1$ | | | V |
| | Common mode | $\pm 10^1$ | | | V |
| Offset Voltage (X, Y) | | | ± 5 | $\pm 30^1$ | mV |
| CMRR (X, Y) | $V_{\text{CM}} = \pm 10\text{ V}$, $f = 50\text{ Hz}$ | 60^1 | 80 | | dB |
| Bias Current (X, Y, Z) | | | 0.8 | 2.0^1 | μA |
| Differential Resistance | | | 10 | | M Ω |
| POWER SUPPLY | | | | | |
| Supply Voltage | | | ± 15 | | V |
| Rated Performance | | | | | V |
| Operating Range | | $\pm 8^1$ | | $\pm 18^1$ | V |
| Supply Current | Quiescent | | 4 | 6^1 | mA |

¹ This specification was tested on all production units at electrical test. Results from those tests are used to calculate outgoing quality levels. All minimum and maximum specifications are guaranteed; however, only this specification was tested on all production units.

² Allow approximately 0.5 ms for settling following power on.

ABSOLUTE MAXIMUM RATINGS

Table 2.

| Parameter | Rating |
|--------------------------------------|-----------------|
| Supply Voltage | ±18 V |
| Internal Power Dissipation | 500 mW |
| Input Voltages ¹ | ±18 V |
| Output Short-Circuit Duration | Indefinite |
| Storage Temperature Range | −65°C to +150°C |
| Operating Temperature Range | |
| AD633J | 0°C to 70°C |
| AD633A | −40°C to +85°C |
| Lead Temperature (Soldering, 60 sec) | 300°C |
| ESD Rating | 1000 V |

¹ For supply voltages less than ±18 V, the absolute maximum input voltage is equal to the supply voltage.

Stresses at or above those listed under Absolute Maximum Ratings may cause permanent damage to the product. This is a stress rating only; functional operation of the product at these or any other conditions above those indicated in the operational section of this specification is not implied. Operation beyond the maximum operating conditions for extended periods may affect product reliability.

THERMAL RESISTANCE

θ_{JA} is specified for the worst-case conditions, that is, a device soldered in a circuit board for surface-mount packages.

Table 3.

| Package Type | θ_{JA} | Unit |
|--------------|---------------|------|
| 8-Lead PDIP | 90 | °C/W |
| 8-Lead SOIC | 155 | °C/W |

ESD CAUTION



ESD (electrostatic discharge) sensitive device. Charged devices and circuit boards can discharge without detection. Although this product features patented or proprietary protection circuitry, damage may occur on devices subjected to high energy ESD. Therefore, proper ESD precautions should be taken to avoid performance degradation or loss of functionality.

PIN CONFIGURATIONS AND FUNCTION DESCRIPTIONS

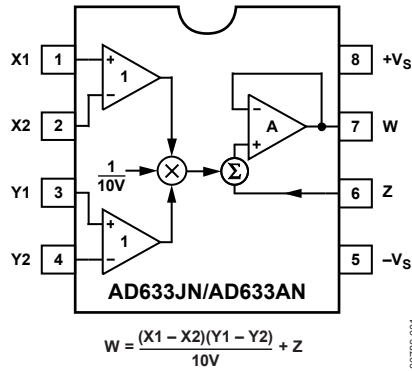

Figure 2. 8-Lead PDIP

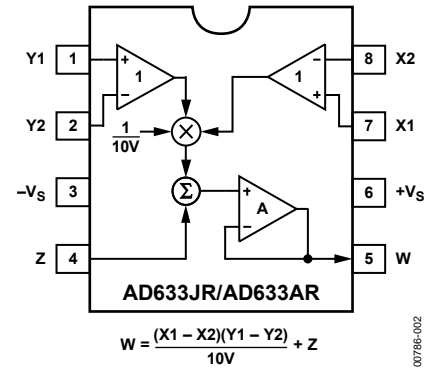

Figure 3. 8-Lead SOIC

Table 4. 8-Lead PDIP Pin Function Descriptions

| Pin No. | Mnemonic | Description |
|---------|----------|-----------------------------------|
| 1 | X1 | X Multiplicand Noninverting Input |
| 2 | X2 | X Multiplicand Inverting Input |
| 3 | Y1 | Y Multiplicand Noninverting Input |
| 4 | Y2 | Y Multiplicand Inverting Input |
| 5 | -Vs | Negative Supply Rail |
| 6 | Z | Summing Input |
| 7 | W | Product Output |
| 8 | +Vs | Positive Supply Rail |

Table 5. 8-Lead SOIC Pin Function Descriptions

| Pin No. | Mnemonic | Description |
|---------|----------|-----------------------------------|
| 1 | Y1 | Y Multiplicand Noninverting Input |
| 2 | Y2 | Y Multiplicand Inverting Input |
| 3 | -Vs | Negative Supply Rail |
| 4 | Z | Summing Input |
| 5 | W | Product Output |
| 6 | +Vs | Positive Supply Rail |
| 7 | X1 | X Multiplicand Noninverting Input |
| 8 | X2 | X Multiplicand Inverting Input |

TYPICAL PERFORMANCE CHARACTERISTICS

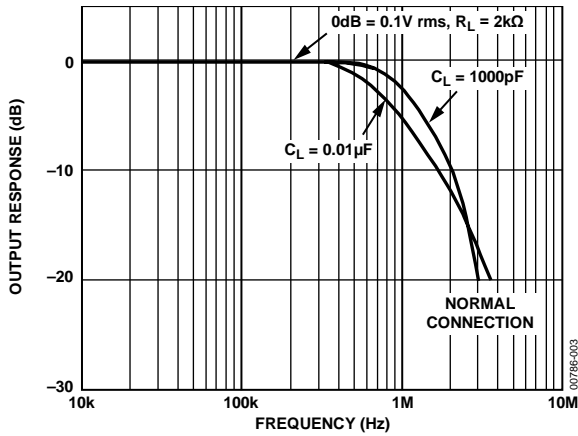

Figure 4. Frequency Response

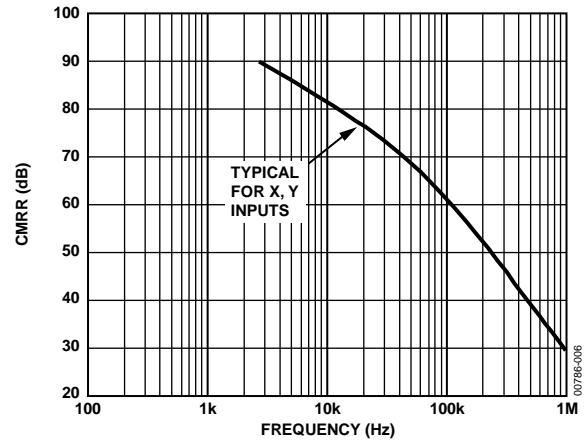

Figure 7. CMRR vs. Frequency

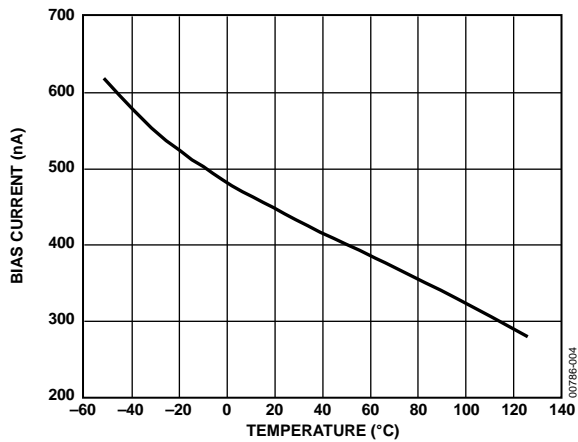

Figure 5. Input Bias Current vs. Temperature (X, Y, or Z Inputs)

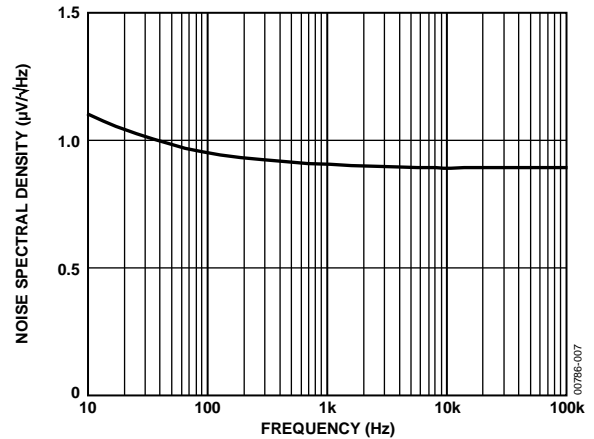

Figure 8. Noise Spectral Density vs. Frequency

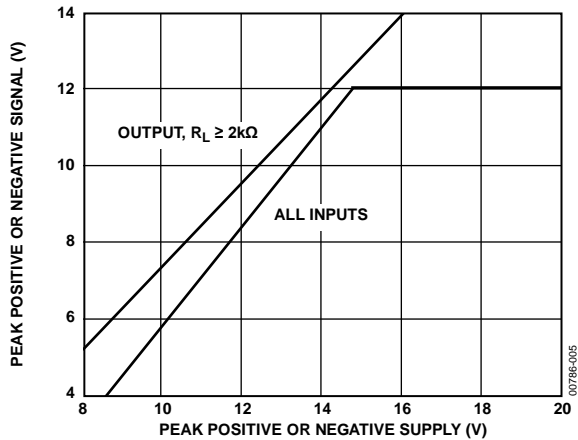

Figure 6. Input and Output Signal Ranges vs. Supply Voltages

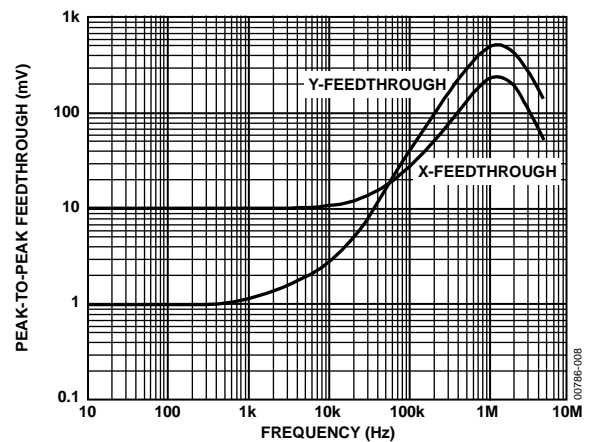

Figure 9. AC Feedthrough vs. Frequency

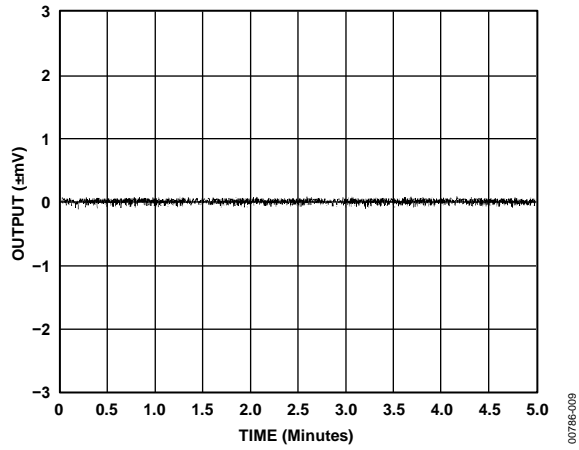

Figure 10. Typical V_{OS} vs. Time, For Five Minutes Following Power Up

FUNCTIONAL DESCRIPTION

The AD633 is a low cost multiplier comprising a translinear core, a buried Zener reference, and a unity-gain connected output amplifier with an accessible summing node. Figure 1 shows the functional block diagram. The differential X and Y inputs are converted to differential currents by voltage-to-current converters. The product of these currents is generated by the multiplying core. A buried Zener reference provides an overall scale factor of 10 V. The sum of $(X \times Y)/10 + Z$ is then applied to the output amplifier. The amplifier summing Node Z allows the user to add two or more multiplier outputs, convert the output voltage to a current, and configure various analog computational functions.

Inspection of the block diagram shows the overall transfer function is

$$W = \frac{(X1 - X2)(Y1 - Y2)}{10 \text{ V}} + Z \quad (1)$$

ERROR SOURCES

Multiplier errors consist primarily of input and output offsets, scale factor error, and nonlinearity in the multiplying core. The input and output offsets can be eliminated by using the optional trim of Figure 11. This scheme reduces the net error to scale factor errors (gain error) and an irreducible nonlinearity component in the multiplying core. The X and Y nonlinearities are typically 0.4% and 0.1% of full scale, respectively. Scale factor error is typically 0.25% of full scale. The high impedance Z input should always reference the ground point of the driven system, particularly if it is remote. Likewise, the differential X and Y inputs should reference their respective grounds to realize the full accuracy of the AD633.

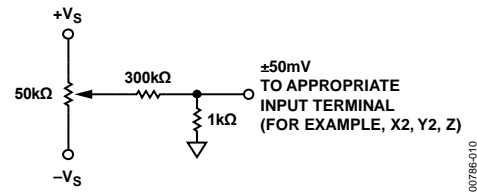

Figure 11. Optional Offset Trim Configuration

00786-010

APPLICATIONS INFORMATION

The AD633 is well suited for such applications as modulation and demodulation, automatic gain control, power measurement, voltage-controlled amplifiers, and frequency doublers. These applications show the pin connections for the AD633JN (8-lead PDIP), which differs from the AD633JR (8-lead SOIC).

MULTIPLIER CONNECTIONS

Figure 12 shows the basic connections for multiplication. The X and Y inputs normally have their negative nodes grounded, but they are fully differential, and in many applications, the grounded inputs may be reversed (to facilitate interfacing with signals of a particular polarity while achieving some desired output polarity), or both may be driven.

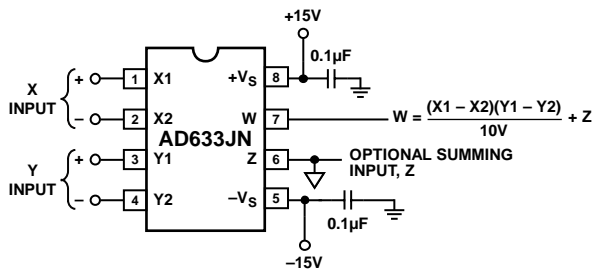

Figure 12. Basic Multiplier Connections (See the Model Results Section)

SQUARING AND FREQUENCY DOUBLING

As is shown in Figure 13, squaring of an input signal, E, is achieved simply by connecting the X and Y inputs in parallel to produce an output of E²/10 V. The input can have either polarity, but the output is positive. However, the output polarity can be reversed by interchanging the X or Y inputs. The Z input can be used to add a further signal to the output.

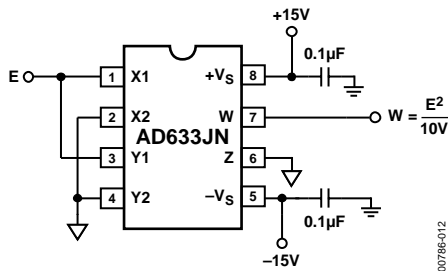

Figure 13. Connections for Squaring

When the input is a sine wave $E \sin \omega t$, this squarer behaves as a frequency doubler, because

$$\frac{(E \sin \omega t)^2}{10 \text{ V}} = \frac{E^2}{20 \text{ V}} (1 - \cos 2 \omega t) \quad (2)$$

Equation 2 shows a dc term at the output that varies strongly with the amplitude of the input, E. This can be avoided using the connections shown in Figure 14, where an RC network is used to generate two signals whose product has no dc term. It uses the identity

$$\cos \theta \sin \theta = \frac{1}{2} (\sin 2 \theta) \quad (3)$$

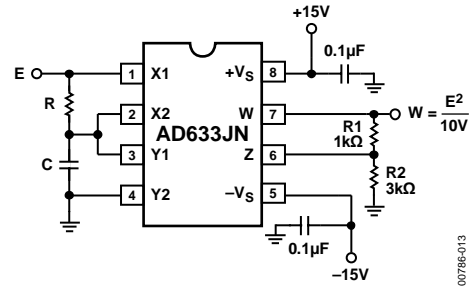

Figure 14. Bounceless Frequency Doubler (See the Model Results Section)

At $\omega_0 = 1/CR$, the X input leads the input signal by 45° (and is attenuated by $\sqrt{2}$), and the Y input lags the X input by 45° (and is also attenuated by $\sqrt{2}$). Because the X and Y inputs are 90° out of phase, the response of the circuit is (satisfying Equation 3)

$$\begin{aligned} W &= \frac{1}{(10 \text{ V})} \frac{E}{\sqrt{2}} (\sin \omega_0 t + 45^\circ) \frac{E}{\sqrt{2}} (\sin \omega_0 t + 45^\circ) \\ &= \frac{E^2}{(40 \text{ V})} (\sin 2 \omega_0 t) \end{aligned} \quad (4)$$

which has no dc component. Resistor R1 and Resistor R2 are included to restore the output amplitude to 10 V for an input amplitude of 10 V.

The amplitude of the output is only a weak function of frequency; the output amplitude is 0.5% too low at $\omega = 0.9 \omega_0$ and $\omega_0 = 1.1 \omega_0$.

GENERATING INVERSE FUNCTIONS

Inverse functions of multiplication, such as division and square rooting, can be implemented by placing a multiplier in the feedback loop of an op amp. Figure 15 shows how to implement square rooting with the transfer function for the condition $E < 0$.

The 1N4148 diode is required to prevent latchup, which can occur in such applications if the input were to change polarity, even momentarily.

$$W = \sqrt{-(10E)V} \quad (5)$$

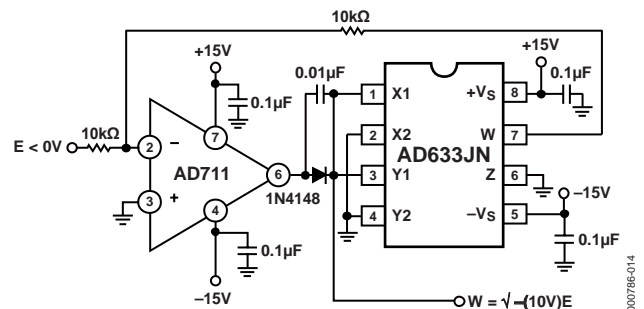

Figure 15. Connections for Square Rooting

Likewise, Figure 16 shows how to implement a divider using a multiplier in a feedback loop. The transfer function for the divider is

$$W = - (10 \text{ V}) \frac{E}{E_x} \tag{6}$$

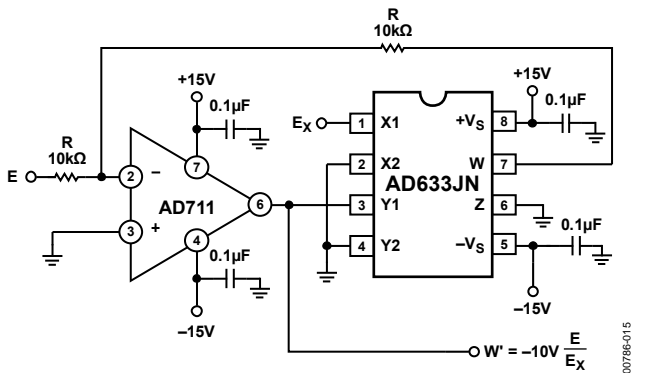

Figure 16. Connections for Division

VARIABLE SCALE FACTOR

In some instances, it may be desirable to use a scaling voltage other than 10 V. The connections shown in Figure 17 increase the gain of the system by the ratio $(R_1 + R_2)/R_1$. This ratio is limited to 100 in practical applications. The summing input, S, can be used to add an additional signal to the output, or it can be grounded.

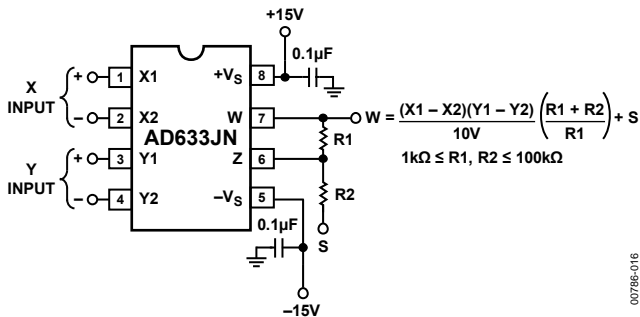

Figure 17. Connections for Variable Scale Factor

CURRENT OUTPUT

The voltage output of the AD633 can be converted to a current output by the addition of a resistor, R, between the W and Z pins of the AD633 as shown in Figure 18.

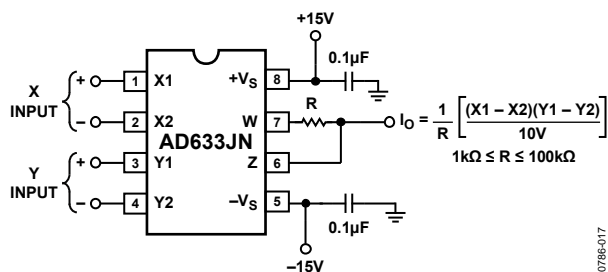

Figure 18. Current Output Connections

This arrangement forms the basis of voltage-controlled integrators and oscillators as is shown later in this section. The transfer function of this circuit has the form

$$I_o = \frac{1}{R} \frac{(X_1 - X_2)(Y_1 - Y_2)}{10 \text{ V}} \tag{7}$$

LINEAR AMPLITUDE MODULATOR

The AD633 can be used as a linear amplitude modulator with no external components. Figure 19 shows the circuit. The carrier and modulation inputs to the AD633 are multiplied to produce a double sideband signal. The carrier signal is fed forward to the Z input of the AD633 where it is summed with the double sideband signal to produce a double sideband with the carrier output.

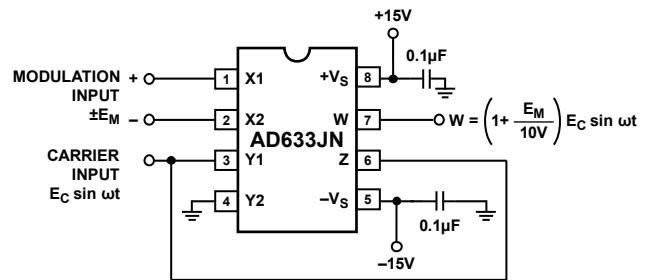

Figure 19. Linear Amplitude Modulator

VOLTAGE-CONTROLLED, LOW-PASS AND HIGH-PASS FILTERS

Figure 20 shows a single multiplier used to build a voltage-controlled, low-pass filter. The voltage at Output A is a result of filtering E_s . The break frequency is modulated by E_c , the control input. The break frequency, f_2 , equals

$$f_2 = \frac{E_c}{10(2\pi RC)} \tag{8}$$

and the roll-off is 6 dB per octave. This output, which is at a high impedance point, may need to be buffered.

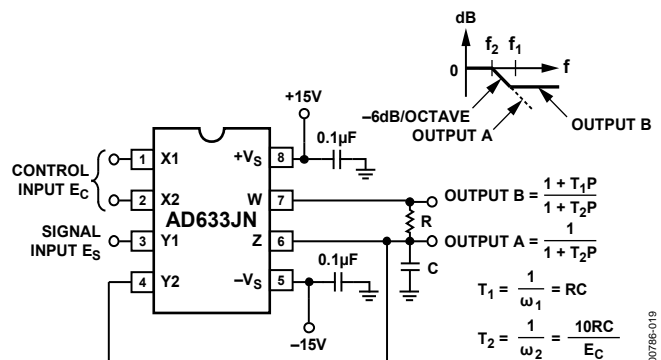

Figure 20. Voltage-Controlled, Low-Pass Filter

The voltage at Output B, the direct output of the AD633, has the same response up to frequency f_1 , the natural breakpoint of RC filter, and then levels off to a constant attenuation of $f_1/f_2 = 10/E_c$

$$f_1 = \frac{1}{2\pi RC} \tag{9}$$

For example, if $R = 8 \text{ k}\Omega$ and $C = 0.002 \text{ }\mu\text{F}$, then Output A has a pole at frequencies from 100 Hz to 10 kHz for E_c ranging from 100 mV to 10 V. Output B has an additional 0 at 10 kHz (and can be loaded because it is the low impedance output of the multiplier). The circuit can be changed to a high-pass filter Z interchanging the resistor and capacitor as shown in Figure 21.

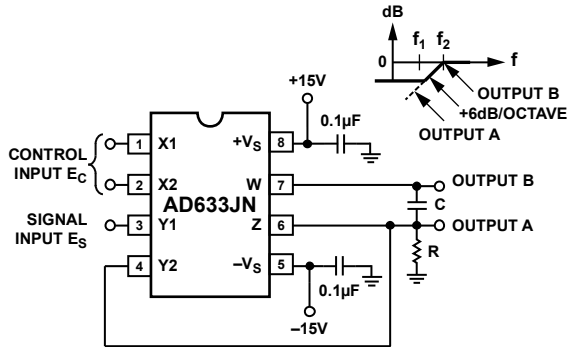

Figure 21. Voltage-Controlled, High-Pass Filter

VOLTAGE-CONTROLLED QUADRATURE OSCILLATOR

Figure 22 shows two multipliers being used to form integrators with controllable time constants in second-order differential equation feedback loop. R2 and R5 provide controlled current output operation. The currents are integrated in capacitors C1 and C2, and the resulting voltages at high impedance are applied to the X inputs of the next AD633. The frequency control input, E_c ,

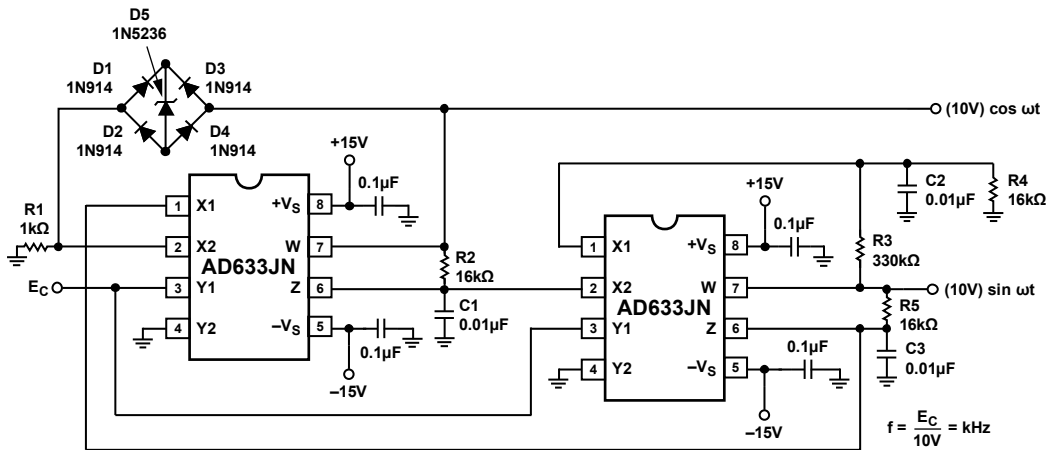

Figure 22. Voltage-Controlled Quadrature Oscillator

connected to the Y inputs, varies the integrator gains with a calibration of 100 Hz/V. The accuracy is limited by the Y input offsets. The practical tuning range of this circuit is 100:1. C2 (proportional to C1 and C3), R3, and R4 provide regenerative feedback to start and maintain oscillation. The diode bridge, D1 through D4 (1N914s), and Zener diode D5 provide economical temperature stabilization and amplitude stabilization at $\pm 8.5 \text{ V}$ by degenerative damping. The output from the second integrator ($10 \text{ V sin } \omega t$) has the lowest distortion.

AUTOMATIC GAIN CONTROL (AGC) AMPLIFIERS

Figure 23 shows an AGC circuit that uses an rms-to-dc converter to measure the amplitude of the output waveform. The AD633 and A1, half of an AD712 dual op amp, form a voltage-controlled amplifier. The rms-to-dc converter, an AD736, measures the rms value of the output signal. Its output drives A2, an integrator/comparator whose output controls the gain of the voltage-controlled amplifier. The 1N4148 diode prevents the output of A2 from going negative. R8, a 50 kΩ variable resistor, sets the output level of the circuit. Feedback around the loop forces the voltages at the inverting and noninverting inputs of A2 to be equal, thus the AGC.

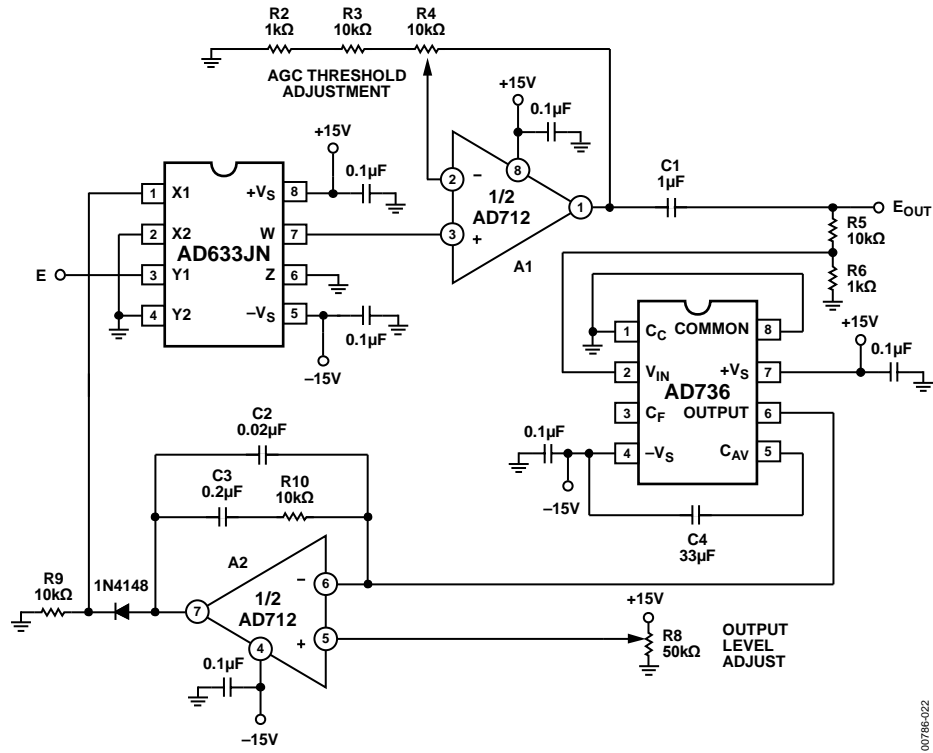

Figure 23. Connections for Use in Automatic Gain Control Circuit

00786-022

MODEL RESULTS

Circuit simulation using SPICE models embedded in various application formats such as PSPICE, Multisim, and SIMetrix is a popular and efficient method of assessing the integrity of a circuit before creating the printed circuit board in which the circuits are ultimately used. Although impossible to demonstrate all of the multiplier functions in every available program, Figure 24 through Figure 41 demonstrate how the schematic and graph for simple dc, sin(x), and pulse applications appear in three popular SPICE programs. If a simulator is not shown here, a good way to progress is to start with a basic dc circuit to verify that the circuit converges and then continue with waveforms that are more complex. When analyzing nonlinear devices such as multipliers, the most common simulation issue is convergence, the iterative process by which SPICE seeks the initial dc bias condition before completely solving the circuit and displaying a graph.

Figure 24 through Figure 41 are arranged schematic first, followed by the graphic result. If the user has a problem with a simulator, the most efficient fix is to contact applications support for the program in use.

EXAMPLES OF DC, SIN, AND PULSE SOLUTIONS USING MULTISIM

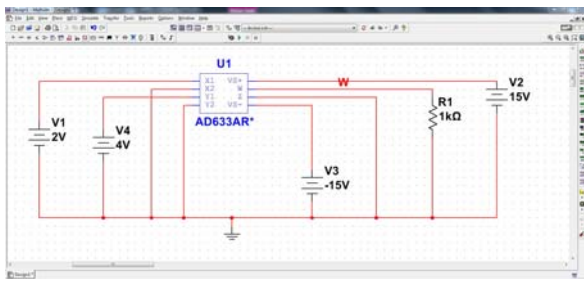

Figure 24. Circuit to Multiply Two Integers Schematic Created in Multisim

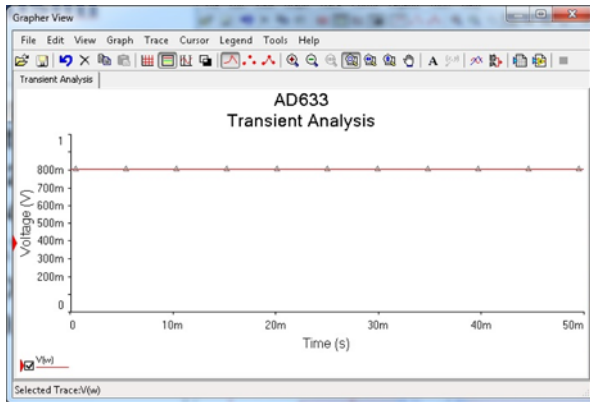

Figure 25. Circuit to Multiply Two Integers Response Graph Displayed in Multisim $(2V \times 4V) / 10V = 0.8V$

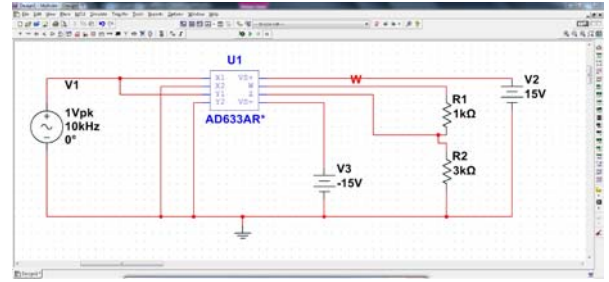

Figure 26. Frequency Doubler Circuit Schematic Created in Multisim

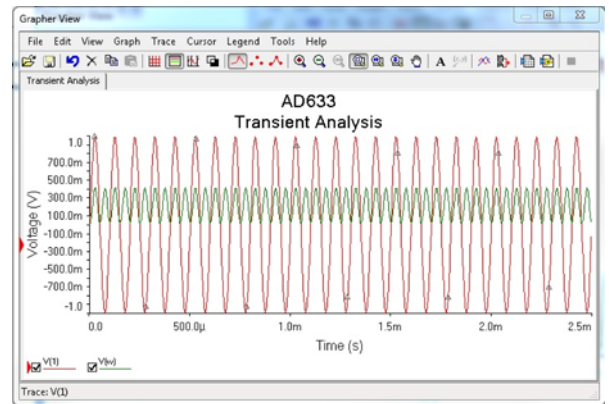

Figure 27. Frequency Doubler Response Graph Displayed in Multisim

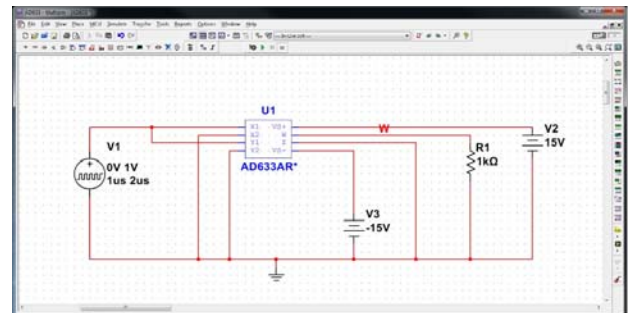

Figure 28. Pulse Circuit Schematic Created in Multisim

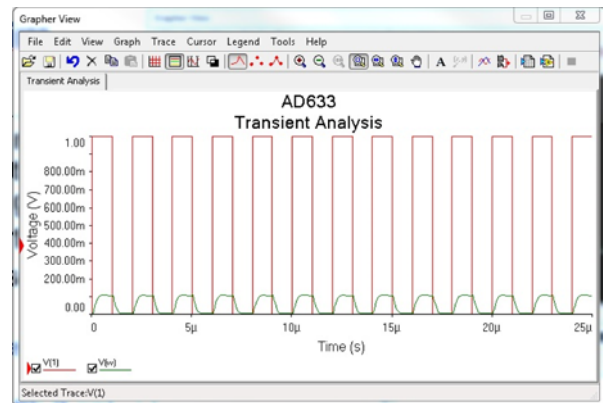

Figure 29. Pulse Circuit Response Graph Displayed in Multisim

EXAMPLES OF DC, SIN, AND PULSE SOLUTIONS USING PSPICE

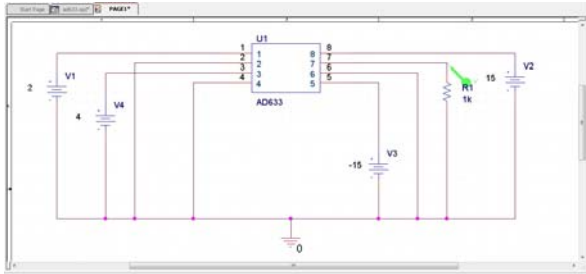

Figure 30. Simple Circuit Schematic Created in PSPICE

00786-130



Figure 31. Simple Circuit Response Graph Displayed in PSPICE
($2V \times 4V$)/ $10V = 0.8V$

00786-131

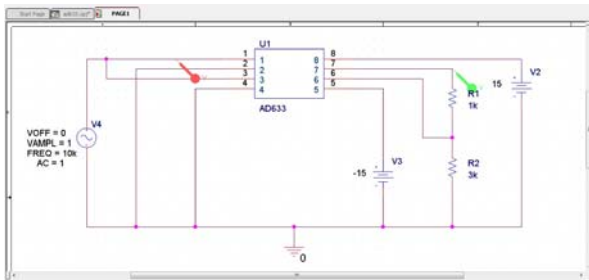

Figure 32. Frequency Doubler Circuit Schematic Created in PSPICE

00786-132

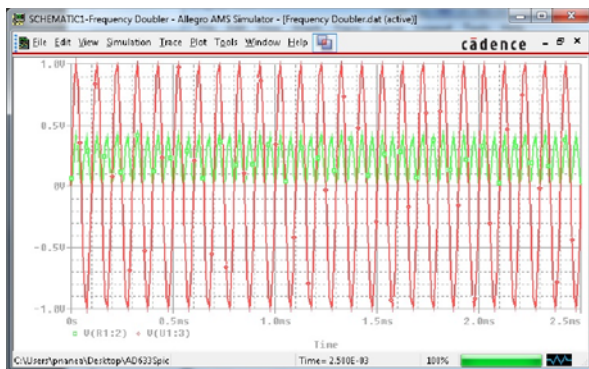

Figure 33. Frequency Doubler Response Graph Displayed in PSPICE

00786-133

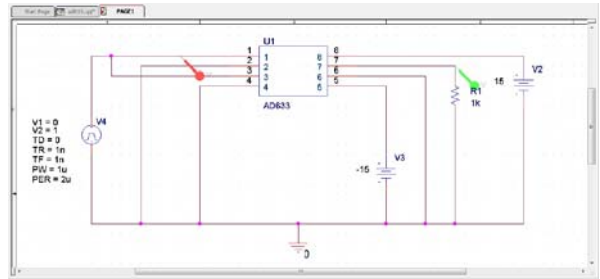

Figure 34. Pulse Circuit Schematic Created in PSPICE

00786-134

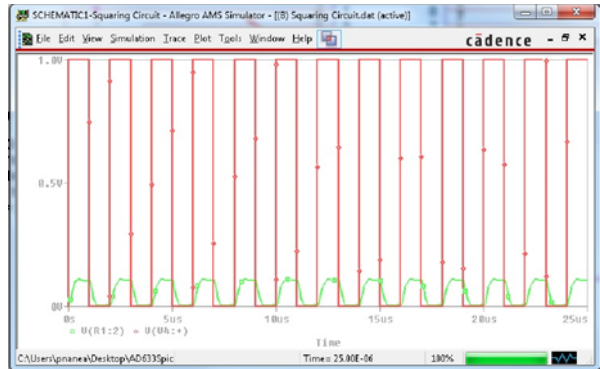

Figure 35. Pulse Circuit Response Graph Displayed in PSPICE

00786-135

EXAMPLES OF DC, SIN, AND PULSE SOLUTIONS USING SIMETRIX

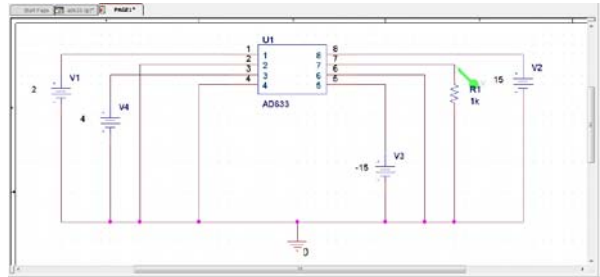

Figure 36. Simple Circuit Schematic Created in SIMetrix

00786-136

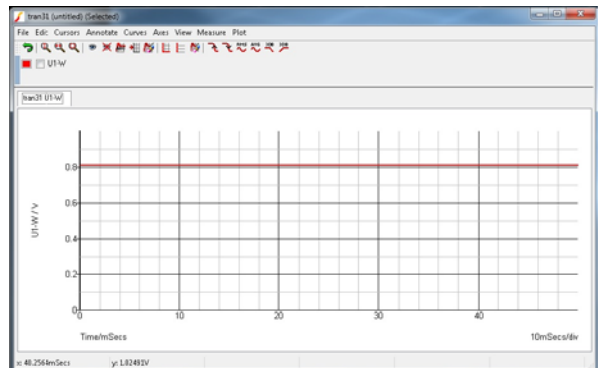

Figure 37. Simple Circuit Response Graph Displayed in SIMetrix
($2V \times 4V$)/ $10V = 0.8V$

00786-137

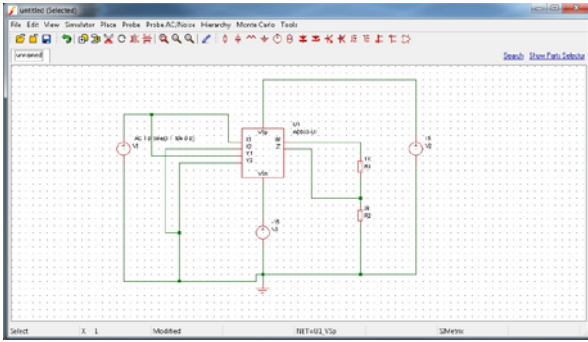

Figure 38. Frequency Doubler Circuit Schematic Created in SIMetrix

00786-138

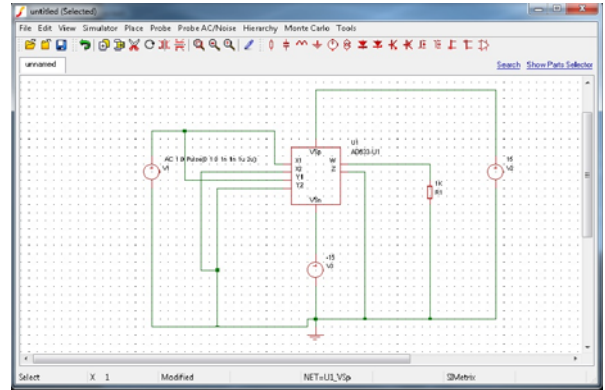

Figure 40. Pulse Circuit Schematic Created in SIMetrix

00786-140



Figure 39. Frequency Doubler Response Graph Displayed in SIMetrix

00786-139

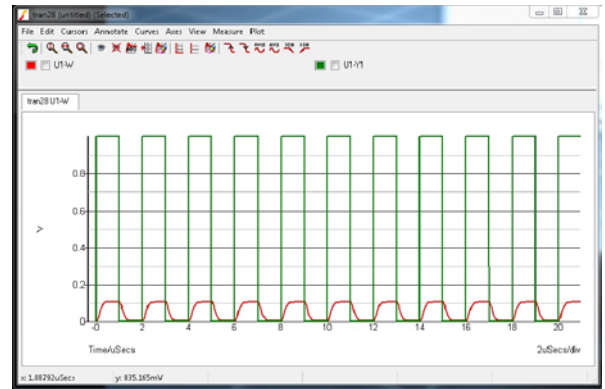

Figure 41. Pulse Circuit Response Displayed in SIMetrix

00786-141

EVALUATION BOARD

The evaluation board of the [AD633](#) enables simple bench-top experimenting to be performed with easy control of the [AD633](#). Built-in flexibility allows convenient configuration to accommodate most operating configurations. Figure 42 is a photograph of the [AD633](#) evaluation board.

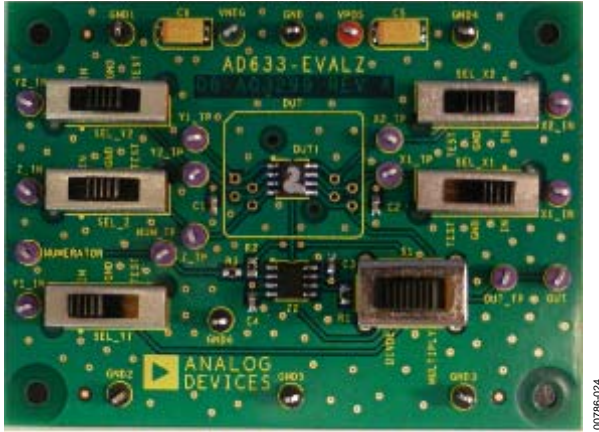

Figure 42. AD633 Evaluation Board

Any dual-polarity power supply capable of providing 10 mA or greater is all that is required to perform the intended tests, in addition to whatever test equipment the user wants.

Referring to the schematic in Figure 49, inputs to the multiplier are differential and dc-coupled. Three-position slide switches enhance flexibility by enabling the multiplier inputs to be connected to an active signal source, to ground, or to a test loop connected directly to the device pin for direct measurements, such as bias current. Inputs may be connected single ended or differentially, but must have a dc path to ground for bias current. If the impedance of an input source is non-zero, an equal value impedance must be connected to the opposite polarity input to avoid introducing additional offset voltage.

The [AD633-EVALZ](#) can be configured for multiplier or divider operation by switch S1. Refer to Figure 16 for divider circuit connections.

Figure 43 through Figure 46 are the signal, power, and ground-plane artworks, and Figure 47 shows the component and circuit side silkscreen. Figure 48 shows the assembly.

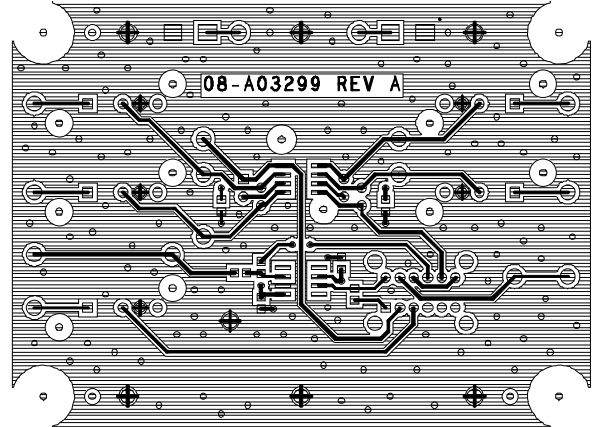

Figure 43. Component Side Copper

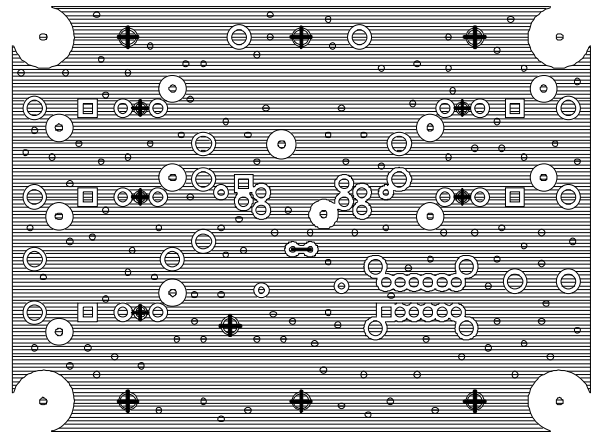

Figure 44. Circuit Side Copper

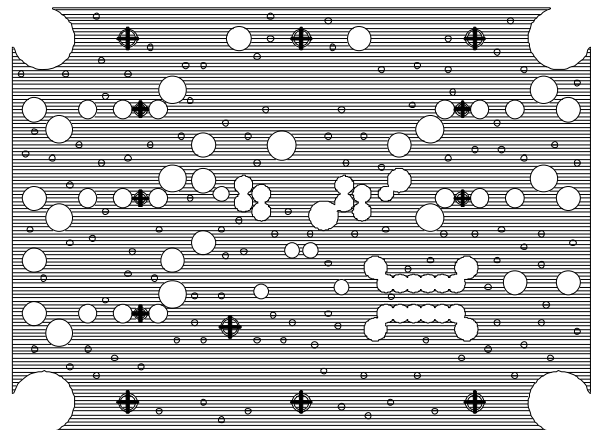

Figure 45. Inner Layer Ground Plane

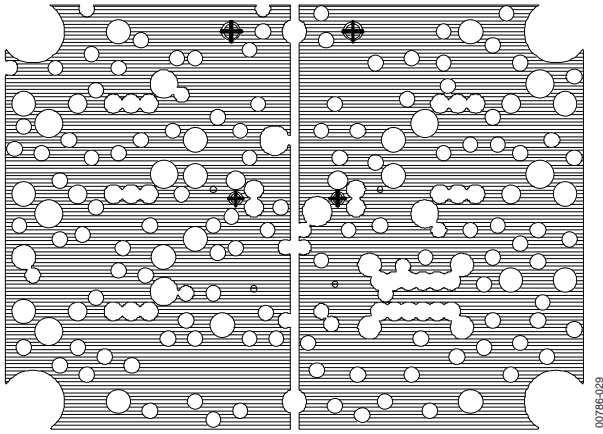

Figure 46. Inner Layer Power Plane

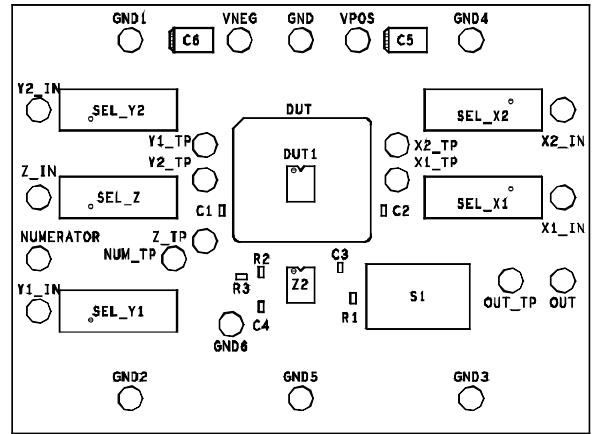

Figure 48. AD633-EVALZ Assembly

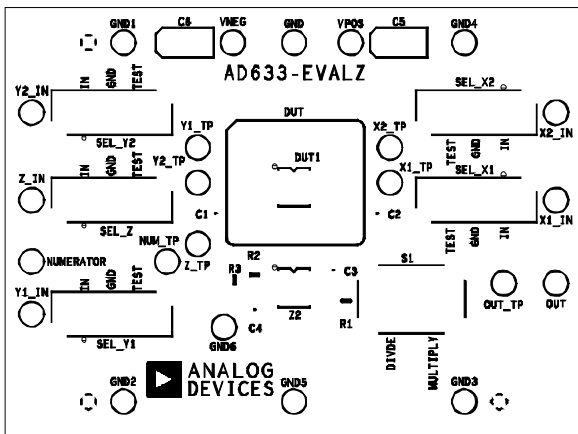

Figure 47. Component Side Silk Screen

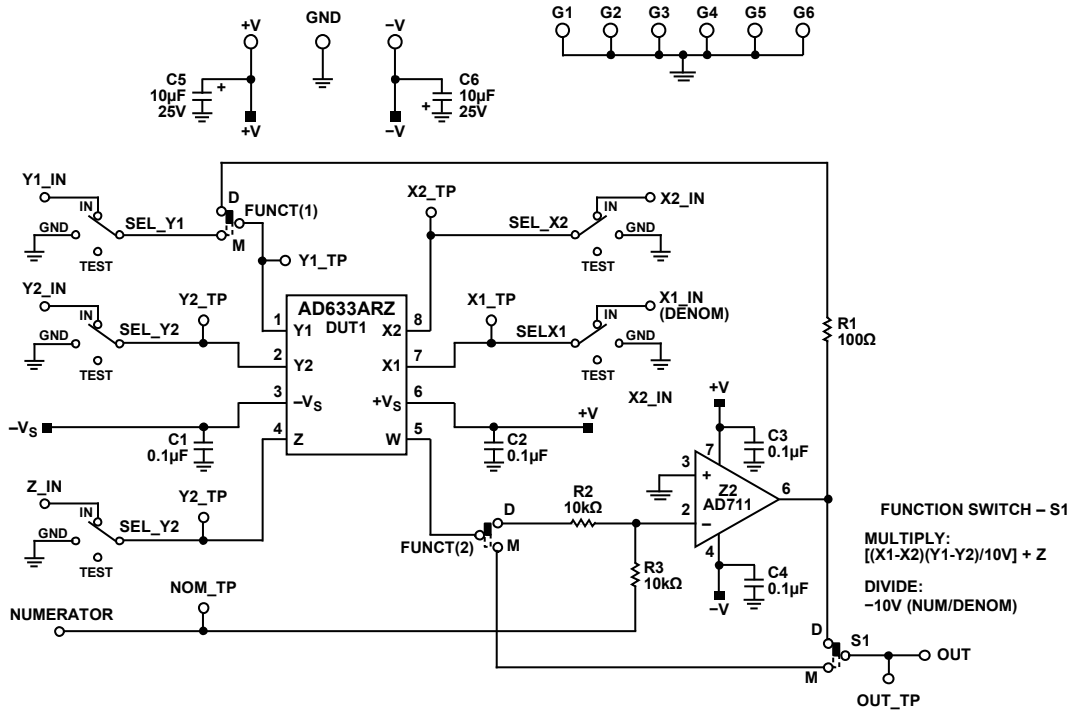

Figure 49. Schematic of the AD633 Evaluation Board

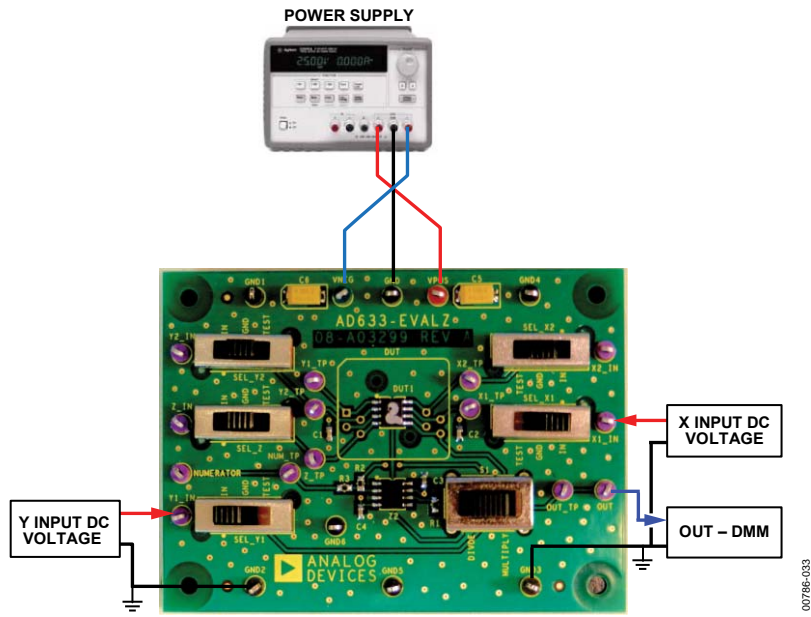
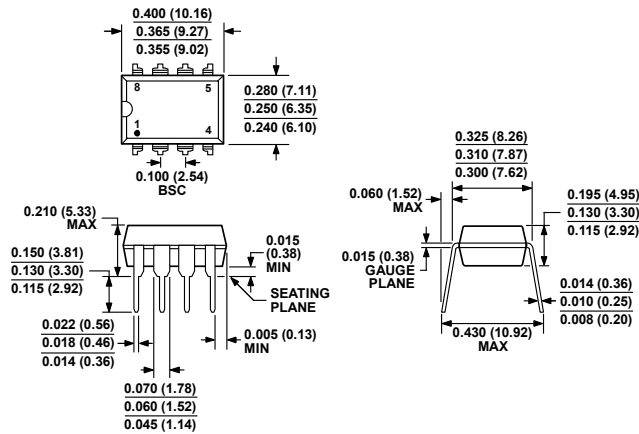

Figure 50. AD633-EVALZ Configured for Bench Experiments

OUTLINE DIMENSIONS



COMPLIANT TO JEDEC STANDARDS MS-001
 CONTROLLING DIMENSIONS ARE IN INCHES; MILLIMETER DIMENSIONS (IN PARENTHESES) ARE ROUNDED-OFF INCH EQUIVALENTS FOR REFERENCE ONLY AND ARE NOT APPROPRIATE FOR USE IN DESIGN. CORNER LEADS MAY BE CONFIGURED AS WHOLE OR HALF LEADS.

Figure 51. 8-Lead Plastic Dual-in-Line Package [PDIP] (N-8)

Dimensions shown in inches and (millimeters)

07906E-A

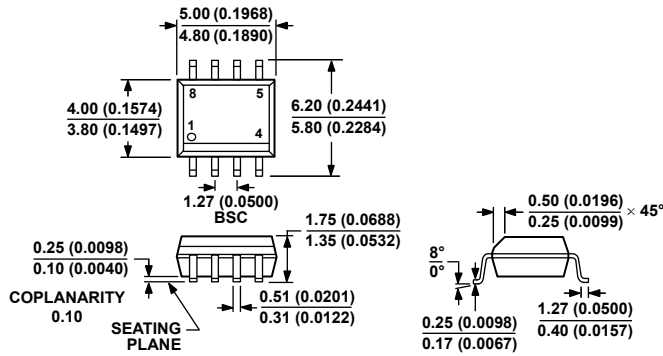

COMPLIANT TO JEDEC STANDARDS MS-012-AA
 CONTROLLING DIMENSIONS ARE IN MILLIMETERS; INCH DIMENSIONS (IN PARENTHESES) ARE ROUNDED-OFF MILLIMETER EQUIVALENTS FOR REFERENCE ONLY AND ARE NOT APPROPRIATE FOR USE IN DESIGN.

Figure 52. 8-Lead Standard Small Outline Package [SOIC_N] Narrow Body (R-8)

Dimensions shown in millimeters and (inches)

012407-A