

### FEATURES

- Small package: 8-lead SOT-23
- Reduced component count
- Incorporates gain resistors and filter resistors
- Low offset voltage: 20  $\mu\text{V}$  maximum
- Low offset drift: 0.3  $\mu\text{V}/^\circ\text{C}$  maximum
- Low gain drift: 25 ppm/ $^\circ\text{C}$  maximum
- High CMR: 140 dB typical
- Low noise: 0.7  $\mu\text{V}$  p-p from 0.01 Hz to 10 Hz
- Single-supply operation: 1.8 V to 5.5 V
- Rail-to-rail output
- Available in 2 fixed-gain models

### APPLICATIONS

- Current sensing
- Strain gauges
- Laser diode control loops
- Portable medical instruments
- Thermocouple amplifiers

### GENERAL DESCRIPTION

The AD8293G80/AD8293G160 are small, low cost, precision instrumentation amplifiers that have low noise and rail-to-rail outputs. They are available in two fixed-gain models: 80 and 160. They incorporate the gain setting resistors and filter resistors, reducing the number of ancillary components. For example, only two external capacitors are needed to implement a 2-pole filter. The AD8293G80/AD8293G160 also feature low offset voltage, offset drift, and gain drift coupled with high common-mode rejection. They are capable of operating on a supply of 1.8 V to 5.5 V.

With a low offset voltage of 20  $\mu\text{V}$  (AD8293G160B), an offset voltage drift of 0.3  $\mu\text{V}/^\circ\text{C}$ , and a voltage noise of only 0.7  $\mu\text{V}$  p-p (0.01 Hz to 10 Hz), the AD8293G80/AD8293G160 are ideal for applications where error sources cannot be tolerated.

#### Rev. 0

Information furnished by Analog Devices is believed to be accurate and reliable. However, no responsibility is assumed by Analog Devices for its use, nor for any infringements of patents or other rights of third parties that may result from its use. Specifications subject to change without notice. No license is granted by implication or otherwise under any patent or patent rights of Analog Devices. Trademarks and registered trademarks are the property of their respective owners.

### FUNCTIONAL BLOCK DIAGRAM

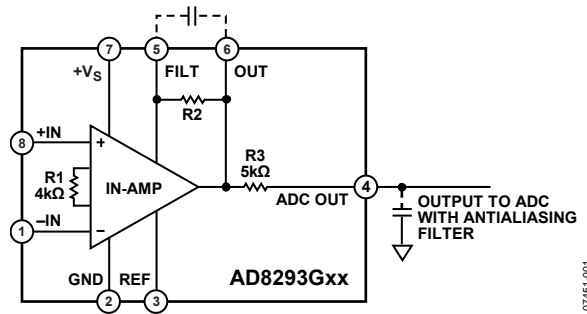

Figure 1.

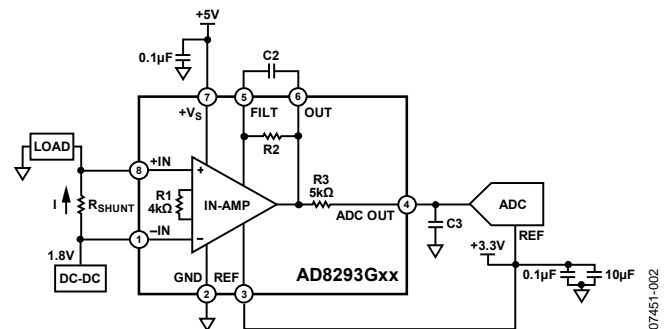

Figure 2. Measuring Current Using the AD8293G80/AD8293G160

Table 1. AD8293Gxx Models and Gains

Model	Gain
AD8293G80	80
AD8293G160	160

Precision instrumentation, position and pressure sensors, medical instrumentation, and strain gauge amplifiers benefit from the low noise, low input bias current, and high common-mode rejection. The small footprint and low cost are ideal for high volume applications.

The small package and low power consumption allow the maximum channel density and the minimum board size required for portable systems. Designed for ease of use, these instrumentation amplifiers, unlike more traditional ones, have a buffered reference, eliminating the need for an additional op amp to set the reference voltage to midsupply.

The AD8293G80/AD8293G160 are specified over the industrial temperature range from  $-40^\circ\text{C}$  to  $+85^\circ\text{C}$ . The AD8293G80/AD8293G160 are available in a halogen-free, Pb-free, 8-lead SOT-23.

## TABLE OF CONTENTS

Features .....	1	Theory of Operation .....	10
Applications.....	1	High PSR and CMR.....	10
Functional Block Diagram .....	1	1/f Noise Correction .....	10
General Description .....	1	Applications Information .....	11
Revision History .....	2	Overview .....	11
Specifications.....	3	Reference Connection .....	11
Electrical Characteristics .....	3	Output Filtering.....	11
Absolute Maximum Ratings.....	5	Clock Feedthrough.....	12
Thermal Resistance .....	5	Power Supply Bypassing.....	12
ESD Caution.....	5	Input Overvoltage Protection .....	12
Pin Configuration and Function Descriptions.....	6	Outline Dimensions .....	13
Typical Performance Characteristics .....	7	Ordering Guide .....	13

## REVISION HISTORY

8/08—Revision 0: Initial Version

## SPECIFICATIONS

### ELECTRICAL CHARACTERISTICS

$V_{CC} = 5.0\text{ V}$ ,  $V_{CM} = -0\text{ V}$ ,  $V_{REF} = 3.3\text{ V}$ ,  $V_{IN} = V_{INP} - V_{INN}$ ,  $T_A = 25^\circ\text{C}$ , tested at ADC OUT, unless otherwise noted. Temperature specifications guaranteed by characterization.

Table 2. A Grade

Parameter	Symbol	Conditions	AD8293G80A			AD8293G160A			Unit
			Min	Typ	Max	Min	Typ	Max	
COMMON-MODE REJECTION	CMR	$V_{CM} = 0\text{ V to } 3.3\text{ V}$ , $-40^\circ\text{C} \leq T_A \leq +85^\circ\text{C}$	94	140		94	140		dB
NOISE PERFORMANCE									
Voltage Noise	$e_{n\text{-p-p}}$	$f = 0.01\text{ Hz to } 10\text{ Hz}$		0.7			0.7		$\mu\text{V p-p}$
Voltage Noise Density	$e_n$	$f = 1\text{ kHz}$		35			35		$\text{nV}/\sqrt{\text{Hz}}$
INPUT CHARACTERISTICS									
Input Offset Voltage	$V_{OS}$	$-40^\circ\text{C} \leq T_A \leq +85^\circ\text{C}$		9	50		9	50	$\mu\text{V}$
vs. Temperature	$\Delta V_{OS}/\Delta T$		0.02	0.3		0.02	0.3		$\mu\text{V}/^\circ\text{C}$
Input Bias Current	$I_B$		0.4	2		0.4	2		nA
Input Offset Current	$I_{OS}$				4			4	nA
Input Operating Impedance									
Differential			50  1			50  1			$\text{M}\Omega  \text{pF}$
Common Mode			10  10			10  10			$\text{G}\Omega  \text{pF}$
Input Voltage Range			0		$V_{CC} - 1.7$	0		$V_{CC} - 1.7$	V
DYNAMIC RESPONSE									
Small Signal Bandwidth <sup>1</sup>	BW	Filter limited		500			500		Hz
Slew Rate	SR			Filter limited			Filter limited		
Settling Time <sup>2</sup>	$t_s$								
0.1%		500 Hz filter, $V_O = 2\text{ V step}$		1.9			1.9		ms
0.01%				2.4			2.4		ms
Internal Clock Frequency				60			60		kHz
GAIN				80			160		
Gain Error		$V_O = 0.075\text{ V to } 4.925\text{ V}$		0.3	1		0.3	1	%
Gain Drift		$-40^\circ\text{C} \leq T_A \leq +85^\circ\text{C}$		5	25		5	25	$\text{ppm}/^\circ\text{C}$
Nonlinearity		$V_O = 0.075\text{ V to } 4.925\text{ V}$		0.003	0.03		0.003	0.03	% FS
OUTPUT CHARACTERISTICS									
Output Voltage High	$V_{OH}$		$V_{CC} - 0.075$			$V_{CC} - 0.075$			V
Output Voltage Low	$V_{OL}$			0.075			0.075		V
Short-Circuit Current	$I_{SC}$		$\pm 35$			$\pm 35$			mA
REFERENCE CHARACTERISTICS									
$V_{REF}$ Range			0.8		$V_{CC} - 0.8$	0.8		$V_{CC} - 0.8$	V
REF Pin Current	$I_{REF}$			0.01	1		0.01	1	nA
POWER SUPPLY									
Operating Range			1.8		5.5	1.8		5.5	V
Power Supply Rejection	PSR	$V_{CC} = 1.8\text{ V to } 5.5\text{ V}$ , $V_{CM} = 0\text{ V}$	94	120		94	120		dB
Supply Current	$I_{SY}$	$I_O = 0\text{ mA}$ , $V_{IN} = 0\text{ V}$ $-40^\circ\text{C} \leq T_A \leq +85^\circ\text{C}$		1.0	1.3		1.0	1.3	mA
					1.5			1.5	mA
TEMPERATURE RANGE									
Specified Range			-40		+85	-40		+85	$^\circ\text{C}$

<sup>1</sup> Higher bandwidths result in higher noise.

<sup>2</sup> Settling time is determined by filter setting.

# AD8293G80/AD8293G160

$V_{CC} = 2.7\text{ V to }5.0\text{ V}$ ,  $V_{CM} = -0\text{ V}$ ,  $V_{REF} = V_{CC}/2$ ,  $V_{IN} = V_{INP} - V_{INN}$ ,  $T_A = 25^\circ\text{C}$ , tested at OUT with  $10\text{ k}\Omega$  load and ADC OUT, unless otherwise noted. Temperature specifications guaranteed by characterization.

**Table 3. B Grade (Tested and Guaranteed over a Wider Supply Range to More Stringent Specifications Than the A Grade)**

Parameter	Symbol	Conditions	AD8293G80B			AD8293G160B			Unit	
			Min	Typ	Max	Min	Typ	Max		
COMMON-MODE REJECTION	CMR	$V_{CC} = 5\text{ V}$ , $V_{CM} = 0\text{ V to }3.3\text{ V}$ ; $-40^\circ\text{C} \leq T_A \leq +85^\circ\text{C}$	110	140		110	140		dB	
		$V_{CC} = 2.7\text{ V}$ , $V_{CM} = 0\text{ V to }1\text{ V}$ ; $-40^\circ\text{C} \leq T_A \leq +85^\circ\text{C}$	106	140		106	140		dB	
NOISE PERFORMANCE										
Voltage Noise	$e_{n,p-p}$	$f = 0.01\text{ Hz to }10\text{ Hz}$		0.7			0.7		$\mu\text{V p-p}$	
Voltage Noise Density	$e_n$	$f = 1\text{ kHz}$		35			35		$\text{nV}/\sqrt{\text{Hz}}$	
INPUT CHARACTERISTICS										
Input Offset Voltage	$V_{OS}$	$-40^\circ\text{C} \leq T_A \leq +85^\circ\text{C}$ , $V_{CC} = 5\text{ V}$		5	30		3	20	$\mu\text{V}$	
vs. Temperature	$\Delta V_{OS}/\Delta T$		$-40^\circ\text{C} \leq T_A \leq +85^\circ\text{C}$ , $V_{CC} = 5\text{ V}$		0.02	0.3		0.02	0.3	$\mu\text{V}/^\circ\text{C}$
vs. Temperature	$\Delta V_{OS}/\Delta T$		$-40^\circ\text{C} \leq T_A \leq +85^\circ\text{C}$ , $V_{CC} = 2.7\text{ V}$		0.01	0.5		0.01	0.5	$\mu\text{V}/^\circ\text{C}$
Input Bias Current	$I_B$	$-40^\circ\text{C} \leq T_A \leq +85^\circ\text{C}$		0.4	2		0.4	2	nA	
Input Offset Current	$I_{OS}$				4			4	nA	
Input Operating Impedance										
Differential				50  1			50  1		$\text{M}\Omega  \text{pF}$	
Common Mode				10  10			10  10		$\text{G}\Omega  \text{pF}$	
Input Voltage Range			0		$V_{CC} - 1.7$	0		$V_{CC} - 1.7$	V	
DYNAMIC RESPONSE										
Small Signal Bandwidth <sup>1</sup>	BW	Filter limited; measured at ADC OUT		500			500		Hz	
Slew Rate	SR	500 Hz filter, $V_O = 2\text{ V}$ step; measured at ADC OUT		Filter limited			Filter limited			
Settling Time <sup>2</sup>	$t_s$			1.9			1.9		ms	
0.1%				2.4			2.4		ms	
0.01%			60			60		kHz		
INTERNAL CLOCK FREQUENCY										
GAIN				80			160			
Gain Error		$V_O = 0.075\text{ V to }4.925\text{ V}$		0.3	0.5		0.3	0.5	%	
Gain Drift		$-40^\circ\text{C} \leq T_A \leq +85^\circ\text{C}$		5	25		5	25	$\text{ppm}/^\circ\text{C}$	
Nonlinearity		$V_O = 0.075\text{ V to }4.925\text{ V}$		0.003	0.009		0.003	0.009	% FS	
OUTPUT CHARACTERISTICS										
Output Voltage High	$V_{OH}$		$V_{CC} - 0.075$			$V_{CC} - 0.075$			V	
Output Voltage Low	$V_{OL}$			0.075			0.075		V	
Short-Circuit Current	$I_{SC}$	$V_{CC} = 5\text{ V}$		$\pm 35$			$\pm 35$		mA	
		$V_{CC} = 2.7\text{ V}$		$\pm 25$			$\pm 25$		mA	
REFERENCE CHARACTERISTICS										
$V_{REF}$ Range			0.8		$V_{CC} - 0.8$	0.8		$V_{CC} - 0.8$	V	
REF Pin Current	$I_{REF}$			0.01	1		0.01	1	nA	
POWER SUPPLY										
Operating Range			1.8		5.5	1.8		5.5	V	
Power Supply Rejection	PSR	$V_{CC} = 1.8\text{ V to }5.5\text{ V}$ , $V_{CM} = 0\text{ V}$	100	120		100	120		dB	
Supply Current	$I_{SY}$	$I_O = 0\text{ mA}$ , $V_{IN} = 0\text{ V}$		1.0	1.3		1.0	1.3	mA	
		$-40^\circ\text{C} \leq T_A \leq +85^\circ\text{C}$			1.5			1.5	mA	
TEMPERATURE RANGE										
Specified Range			-40		+85	-40		+85	$^\circ\text{C}$	

<sup>1</sup> Higher bandwidths result in higher noise.

<sup>2</sup> Settling time is determined by filter setting.

## ABSOLUTE MAXIMUM RATINGS

Table 4.

Parameter	Rating
Supply Voltage	6 V
Input Voltage	+V <sub>SUPPLY</sub>
Differential Input Voltage <sup>1</sup>	±V <sub>SUPPLY</sub>
Output Short-Circuit Duration to GND	Indefinite
Storage Temperature Range (RJ Package)	–65°C to +150°C
Operating Temperature Range	–40°C to +85°C
Junction Temperature Range (RJ Package)	–65°C to +150°C
Lead Temperature (Soldering, 10 sec)	300°C

<sup>1</sup> Differential input voltage is limited to ±5.0 V, the supply voltage, or whichever is less.

Stresses above those listed under Absolute Maximum Ratings may cause permanent damage to the device. This is a stress rating only; functional operation of the device at these or any other conditions above those indicated in the operational section of this specification is not implied. Exposure to absolute maximum rating conditions for extended periods may affect device reliability.

### THERMAL RESISTANCE

$\theta_{JA}$  is specified for the worst-case conditions, that is, a device soldered in a circuit board for surface-mount packages.

Table 5.

Package Type	$\theta_{JA}$ <sup>1</sup>	$\theta_{JC}$	Unit
8-Lead SOT-23 (RJ)	211.5	91.99	°C/W

<sup>1</sup>  $\theta_{JA}$  is specified for the nominal conditions, that is,  $\theta_{JA}$  is specified for the device soldered on a circuit board.

### ESD CAUTION



**ESD (electrostatic discharge) sensitive device.** Charged devices and circuit boards can discharge without detection. Although this product features patented or proprietary protection circuitry, damage may occur on devices subjected to high energy ESD. Therefore, proper ESD precautions should be taken to avoid performance degradation or loss of functionality.

# AD8293G80/AD8293G160

## PIN CONFIGURATION AND FUNCTION DESCRIPTIONS



Figure 3. Pin Configuration

Table 6. Pin Function Descriptions

Pin No.	Mnemonic	Description
1	-IN	Inverting Input Terminal (True Differential Input)
2	GND	Ground
3	REF	Reference Voltage Terminal (Drive This Terminal to Level-Shift the Output)
4	ADC OUT	Output with Series 5 k $\Omega$ Resistor for Use with an Antialiasing Filter
5	FILT	Place a capacitor across FILT and OUT to limit the amount of switching noise at the output (see Applications Information)
6	OUT	Output Terminal Without Integrated Filter
7	+Vs	Positive Power Supply Terminal
8	+IN	Noninverting Input Terminal (True Differential Input)

# TYPICAL PERFORMANCE CHARACTERISTICS

$T_A = 25^\circ\text{C}$ ,  $V_{CC} = 5\text{ V}$ , and  $V_{REF} = V_{CC}/2$ ;  $G = 80$ ,  $C_2 = 1300\text{ pF}$ , and  $C_3 = 39\text{ nF}$ ;  $G = 160$ ,  $C_2 = 680\text{ pF}$ , and  $C_3 = 39\text{ nF}$ , unless otherwise specified.



Figure 4. Gain vs. Frequency



Figure 7. Gain vs. Frequency

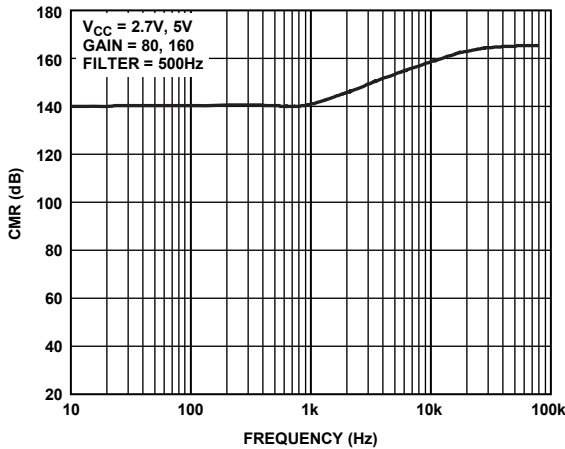

Figure 5. Common-Mode Rejection (CMR) vs. Frequency

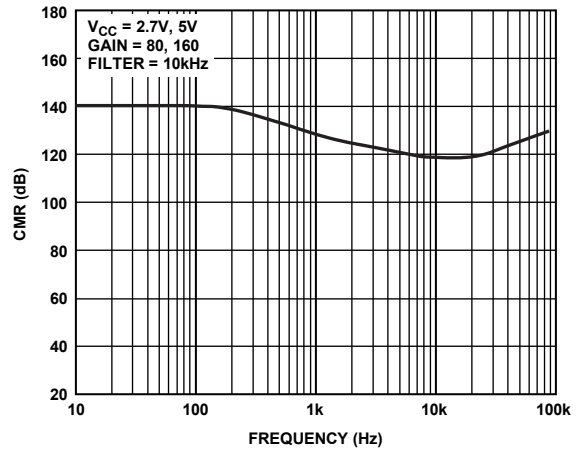

Figure 8. Common-Mode Rejection (CMR) vs. Frequency

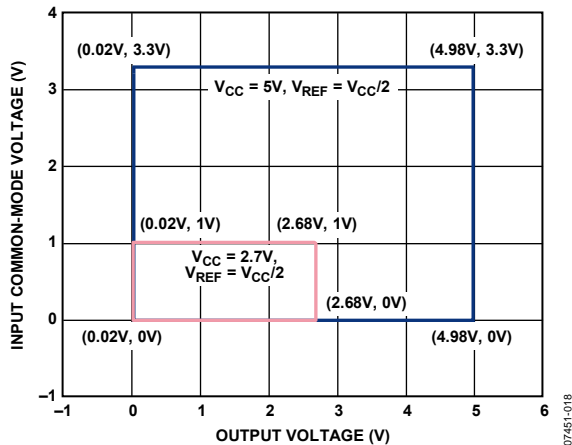

Figure 6. Input Common-Mode Voltage Range vs. Output Voltage,  $G = 80$

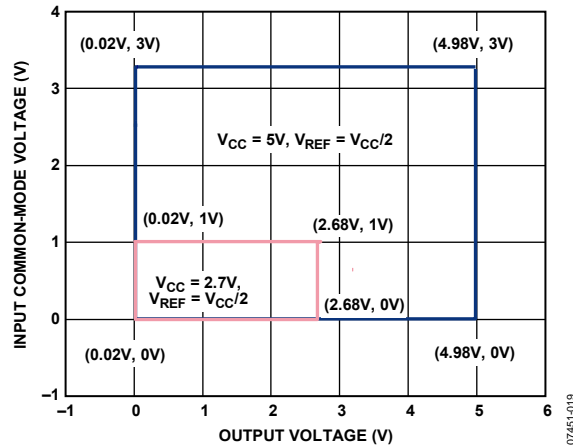

Figure 9. Input Common-Mode Voltage Range vs. Output Voltage,  $G = 160$

# AD8293G80/AD8293G160

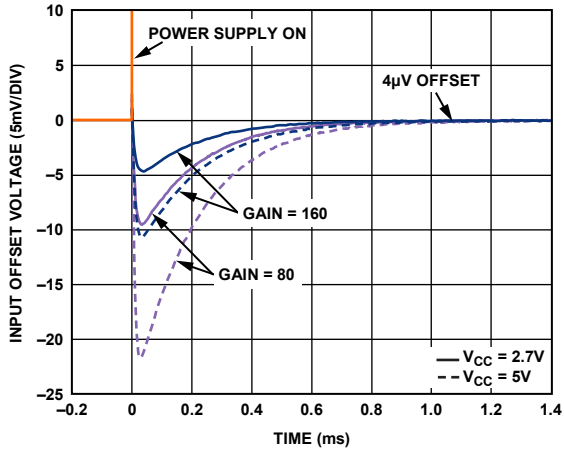

Figure 10. Input Offset Voltage vs. Turn-On Time, Filter = 500 Hz

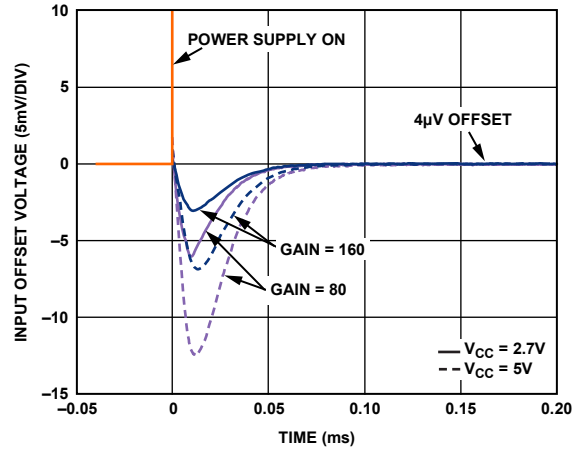

Figure 13. Input Offset Voltage vs. Turn-On Time, Filter = 10 kHz

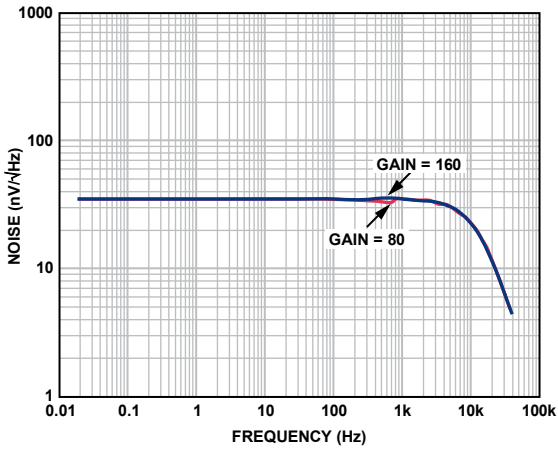

Figure 11. Voltage Noise Density

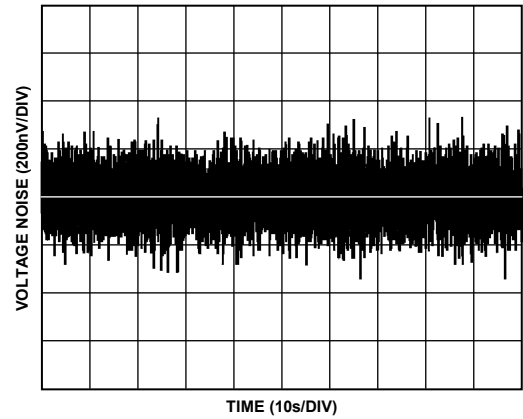

Figure 14. 0.01 Hz to 10 Hz Voltage Noise

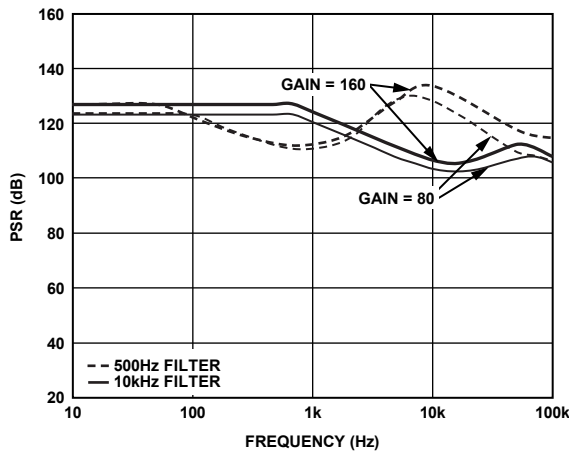

Figure 12. Power Supply Rejection (PSR) vs. Frequency

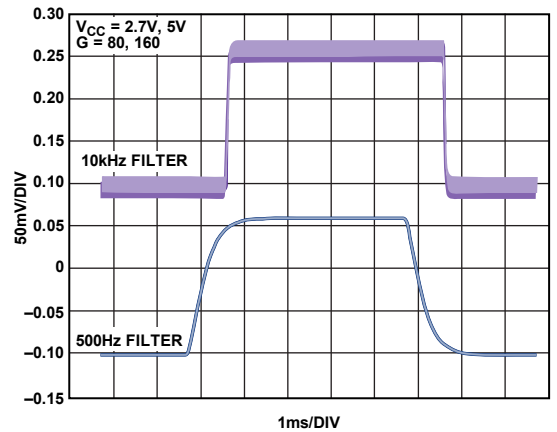

Figure 15. Small Signal Step Response





Figure 16. Large Signal Step Response

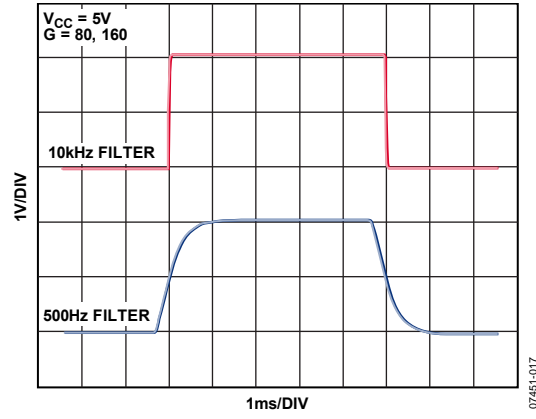

Figure 17. Large Signal Step Response

## THEORY OF OPERATION

The AD8293G80/AD8293G160 are precision current-mode correction instrumentation amplifiers capable of single-supply operation. The current-mode correction topology results in excellent accuracy. Figure 18 shows a simplified diagram illustrating the basic operation of the AD8293G80/AD8293G160 (without correction). The circuit consists of a voltage-to-current amplifier (M1 to M6), followed by a current-to-voltage amplifier (R2 and A1). Application of a differential input voltage forces a current through External Resistor R1, resulting in conversion of the input voltage to a signal current. Transistor M3 to Transistor M6 transfer twice this signal current to the inverting input of the op amp A1. Amplifier A1 and External Resistor R2 form a current-to-voltage converter to produce a rail-to-rail output voltage at  $V_{OUT}$ .

Op amp A1 is a high precision auto-zero amplifier. This amplifier preserves the performance of the autocorrecting, current-mode amplifier topology while offering the user a true voltage-in, voltage-out instrumentation amplifier. Offset errors are corrected internally.

An external reference voltage is applied to the noninverting input of A1 to set the output reference level. External Capacitor C2 is used to filter out correction noise.

## HIGH PSR AND CMR

Common-mode rejection and power supply rejection indicate the amount that the offset voltage of an amplifier changes when its common-mode input voltage or power supply voltage changes. The autocorrection architecture of the AD8293G80/AD8293G160 continuously corrects for offset errors, including those induced by changes in input or supply voltage, resulting in exceptional rejection performance. The continuous autocorrection provides great CMR and PSR performances over the entire operating temperature range ( $-40^{\circ}\text{C}$  to  $+85^{\circ}\text{C}$ ).

The parasitic resistance in series with R2 does not degrade CMR, but causes a small gain error and a very small offset error. Therefore, an external buffer amplifier is not required to drive  $V_{REF}$  to maintain excellent CMR performance. This helps reduce system costs over conventional instrumentation amplifiers.

## 1/f NOISE CORRECTION

Flicker noise, also known as  $1/f$  noise, is noise inherent in the physics of semiconductor devices and decreases 10 dB per decade. The  $1/f$  corner frequency of an amplifier is the frequency at which the flicker noise is equal to the broadband noise of the amplifier. At lower frequencies, flicker noise dominates, causing large errors in low frequency or dc applications.

Flicker noise is seen effectively as a slowly varying offset error, which is reduced by the autocorrection topology of the AD8293G80/AD8293G160. This allows the AD8293G80/AD8293G160 to have lower noise near dc than standard low noise instrumentation amplifiers.



Figure 18. Simplified Schematic

## APPLICATIONS INFORMATION

### OVERVIEW

The AD8293G80/AD8293G160 reduce board area by integrating filter components, such as Resistors R1, R2, and R3, as shown in Figure 19. Two outputs are available to the user: OUT (Pin 6) and ADC OUT (Pin 4). The difference between the two is the inclusion of a series 5 kΩ resistor at ADC OUT. With the addition of an external capacitor, C3, ADC OUT forms a second filter, comprising of the 5 kΩ resistor and C3, which can be used as an ADC anti-aliasing filter. In contrast, OUT is the direct output of the instrumentation amplifier. When using the antialiasing filter, there is slightly less switching ripple at ADC OUT than when obtaining the signal directly from OUT.

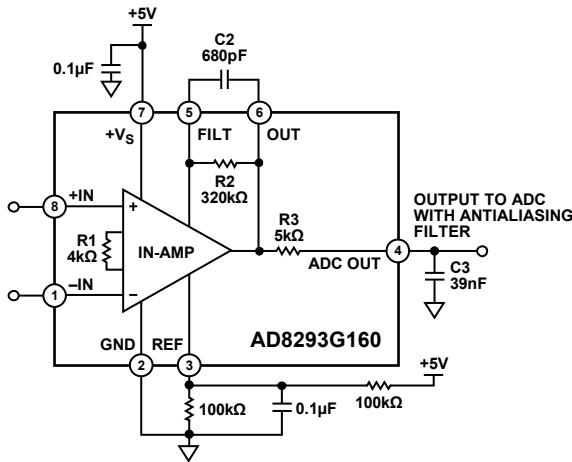

Figure 19. AD8293G160 with Antialiasing Filter and Level-Shifted Output (Using the Resistor Divider at the REF Pin, the Output Is Biased at 2.5 V)

### REFERENCE CONNECTION

Unlike traditional 3-op-amp instrumentation amplifiers, parasitic resistance in series with REF (Pin 3) does not degrade CMR performance. The AD8293G80/AD8293G160 can attain extremely high CMR performance without the use of an external buffer amplifier to drive the REF pin, which is required by industry-standard instrumentation amplifiers. Reducing the need for buffer amplifiers to drive the REF pin helps to save valuable printed circuit board (PCB) space and minimizes system costs.

For optimal performance in single-supply applications, REF should be set with a low noise precision voltage reference, such as the ADR44x (see Figure 20). However, for a lower system cost, the reference voltage can be set with a simple resistor voltage divider between the supply and GND (see Figure 19). This configuration results in degraded output offset performance if the resistors deviate from their ideal values. In dual-supply applications,  $V_{REF}$  can simply be connected to GND.

The REF pin current is approximately 10 pA, and as a result, an external buffer is not required.

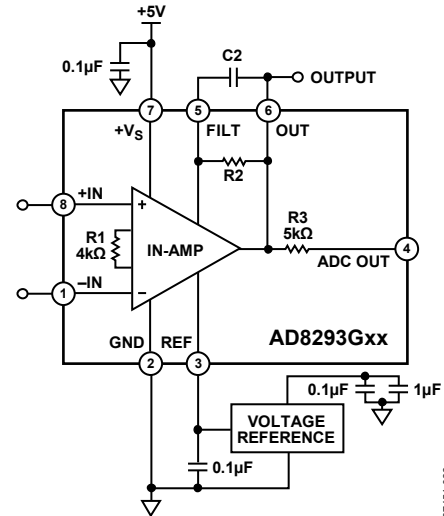

Figure 20. Operating on a Single Supply Using an External Voltage Reference (The Output Can Be Used Without an Antialiasing Filter if the Signal Bandwidth Is < 10 Hz)

### OUTPUT FILTERING

The output of the AD8293G80/AD8293G160 can be filtered to reduce switching ripple. Two filters can be used in conjunction to set the filter frequency. In the example that follows, two 700 Hz filters are used in conjunction to form a 500 Hz (recommended) bandwidth. Because the filter resistors are integrated in the AD8293G80/AD8293G160, only external capacitors are needed to set the filter frequencies.

The primary filter is needed to limit the amount of switching noise at the output. Regardless of the output that is being used, OUT or ADC OUT, the primary filter comprising R2 and C2 must be implemented. The R2 value depends on the model; Table 7 shows the R2 value for each model.

Table 7. Internal R2 Values

Model	R2 (kΩ)
AD8293G80	160
AD8293G160	320

The following equation results in the C2 value needed to set a 700 Hz primary filter. For a gain of 160, substitute R2 with 320 kΩ; for a gain of 80, substitute R2 with 160 kΩ.

$$C2 = 1/(700 \times 2 \times \pi \times R2)$$

Adding an external capacitor, C3, and measuring the output from ADC OUT further reduces the correction ripple. The internal 5 kΩ resistor, labeled R3 in Figure 18, forms a low-pass filter with C3. This low-pass filter is the secondary filter. Set to 700 Hz, the secondary filter equation for C3 is as follows:

$$C3 = 1/(700 \times 2 \times \pi \times 5 \text{ k}\Omega)$$

# AD8293G80/AD8293G160

The addition of another single pole of 700 Hz on the output (from the secondary filter in Figure 18) is required for bandwidths greater than 10 Hz. These two filters, together, produce an overall bandwidth of 500 Hz. The internal resistors, R2 and R3, have an absolute tolerance of 20%. Table 8 lists the standard capacitors needed to create a filter with an overall bandwidth of 500 Hz.

**Table 8. Standard Capacitors Used to Form a Filter with an Overall Bandwidth of 500 Hz**

Model	C2 (pF)	C3 (nF)
AD8293G80	1300	39
AD8293G160	680	39

For applications with low bandwidths (<10 Hz), only the primary filter is required. In such an event, the high frequency noise from the auto-zero amplifier (output amplifier) is not filtered before the following stage.

## CLOCK FEEDTHROUGH

The AD8293G80/AD8293G160 use two synchronized clocks to perform the autocorrection. The input voltage-to-current amplifiers are corrected at 60 kHz.

Trace amounts of these clock frequencies can be observed at the OUT pin. The amount of visible correction feedthrough is dependent on the values of the filters set by R2/C2. Use ADC OUT to create a filter using R3/C3 to further reduce correction feedthrough as described in the Output Filtering section.

## POWER SUPPLY BYPASSING

The AD8293G80/AD8293G160 use internally generated clock signals to perform autocorrection. As a result, proper bypassing is necessary to achieve optimum performance. Inadequate or improper bypassing of the supply lines can lead to excessive noise and offset voltage.

A 0.1 μF surface-mount capacitor should be connected between the supply lines. This capacitor is necessary to minimize ripple from the correction clocks inside the IC. For dual-supply operation, a 0.1 μF (ceramic) surface-mount capacitor should be connected from each supply pin to GND.

For single-supply operation, a 0.1 μF surface-mount capacitor should be connected from the supply line to GND.

All bypass capacitors should be positioned as close to the DUT supply pins as possible, especially the bypass capacitor between the supplies. Placement of the bypass capacitor on the back of the board directly under the DUT is preferred.

## INPUT OVERVOLTAGE PROTECTION

All terminals of the AD8293G80/AD8293G160 are protected against ESD. In the case of a dc overload voltage beyond either supply, a large current would flow directly through the ESD protection diodes. If such a condition can occur, an external resistor should be used in series with the inputs to limit current for voltages beyond the supply rails. The AD8293G80/AD8293G160 can safely handle 5 mA of continuous current, resulting in an external resistor selection of

$$R_{EXT} = (V_{IN} - V_S)/5 \text{ mA}$$



Figure 21. Measuring Current Through a Shunt Resistor (Filter Is Set to 500 Hz)

# OUTLINE DIMENSIONS



COMPLIANT TO JEDEC STANDARDS MO-178-BA

Figure 22. 8-Lead Small Outline Transistor Package [SOT-23] (RJ-8)

Dimensions shown in millimeters

## ORDERING GUIDE

Model	Gain	Temperature Range	Package Description	Package Option	Branding
AD8293G80ARJZ-R2 <sup>1</sup>	80	-40°C to +85°C	8-Lead SOT-23	RJ-8	Y1H
AD8293G80ARJZ-R7 <sup>1</sup>	80	-40°C to +85°C	8-Lead SOT-23	RJ-8	Y1H
AD8293G80ARJZ-RL <sup>1</sup>	80	-40°C to +85°C	8-Lead SOT-23	RJ-8	Y1H
AD8293G80BRJZ-R2 <sup>1</sup>	80	-40°C to +85°C	8-Lead SOT-23	RJ-8	Y1N
AD8293G80BRJZ-R7 <sup>1</sup>	80	-40°C to +85°C	8-Lead SOT-23	RJ-8	Y1N
AD8293G80BRJZ-RL <sup>1</sup>	80	-40°C to +85°C	8-Lead SOT-23	RJ-8	Y1N
AD8293G160ARJZ-R2 <sup>1</sup>	160	-40°C to +85°C	8-Lead SOT-23	RJ-8	Y11
AD8293G160ARJZ-R7 <sup>1</sup>	160	-40°C to +85°C	8-Lead SOT-23	RJ-8	Y11
AD8293G160ARJZ-RL <sup>1</sup>	160	-40°C to +85°C	8-Lead SOT-23	RJ-8	Y11
AD8293G160BRJZ-R2 <sup>1</sup>	160	-40°C to +85°C	8-Lead SOT-23	RJ-8	Y1K
AD8293G160BRJZ-R7 <sup>1</sup>	160	-40°C to +85°C	8-Lead SOT-23	RJ-8	Y1K
AD8293G160BRJZ-RL <sup>1</sup>	160	-40°C to +85°C	8-Lead SOT-23	RJ-8	Y1K

<sup>1</sup> Z = RoHS Compliant Part.

**AD8293G80/AD8293G160**

**NOTES**

**NOTES**