

**-2 V to 70 V Wide Input Voltage Range, 2.2 MHz High Bandwidth,  
Current-Sense Amplifier with PWM Rejection and Gain 20 V/V**

**GENERAL DESCRIPTION**

**FEATURES**

- ▶ 2.2 MHz small signal, -3 dB bandwidth
- ▶ In-package Trim Core (DigiTrim™)
  - ▶ Precision without chopping and/or autozero
  - ▶ Typical  $\pm 0.21 \mu\text{V}/^\circ\text{C}$  offset drift
  - ▶ Maximum  $\pm 200 \mu\text{V}$  voltage-offset over temperature range
  - ▶ Typical DC CMRR: 142 dB
  - ▶ Typical AC CMRR at 50 kHz: 96 dB
- ▶ Wide common-mode input voltage range
  - ▶ -2 V to +70 V, continuous operation
  - ▶ -20 V to +85 V, continuous survival
- ▶ Initial gain: 20 V/V
- ▶ Wide operating temperature range:  $-40^\circ\text{C}$  to  $+125^\circ\text{C}$
- ▶ Bidirectional operation
- ▶ 2.9 V to 5.5 V power-supply operating range
- ▶ Available in 8-lead, SOIC\_N package and 8-lead, MSOP package
- ▶ AEC-Q100 qualified for automotive applications

**APPLICATIONS**

- ▶ In-phase or High-side current sensing in
  - ▶ Motor control in BLDC motors, Low-inductance motors
  - ▶ Bidirectional 48 V to 12 V DC-DC converters
  - ▶ Solenoid controls
  - ▶ Power rail monitoring
- ▶ Low-side current sensing

**TYPICAL APPLICATION CIRCUIT**

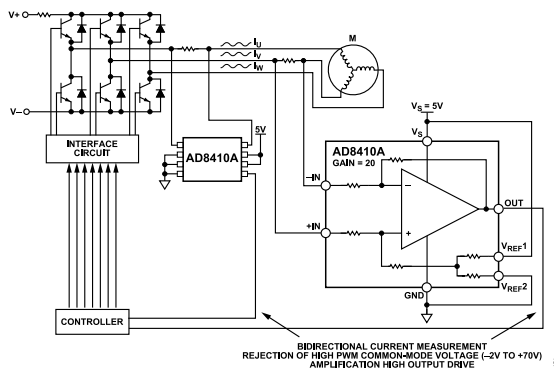

**Figure 1. AD8410A in BLDC Motor Control Application**

The AD8410A<sup>1</sup> is a high voltage, high bandwidth current-sense amplifier. The device features an initial gain of 20 V/V, with a 2.2 MHz bandwidth with a maximum  $\pm 0.13\%$  gain error over the entire temperature range. The buffered output voltage directly interfaces with any typical converter. The AD8410A has a minimum DC common-mode rejection ratio (CMRR) of 123 dB from -2 V to +70 V. The AD8410A performs bidirectional current measurements across a shunt resistor in a variety of industrial and automotive applications.

The AD8410A offers breakthrough performance throughout the  $-40^\circ\text{C}$  to  $+125^\circ\text{C}$  temperature range. The device features an in-package trim core, which leads to a typical offset drift of  $\pm 0.21 \mu\text{V}/^\circ\text{C}$  (based on Box Method, see Figure 56) throughout the operating temperature range and the common-mode voltage range without the need for chopping and autozero clocks (which could lead to intermodulation in the application). The device includes circuitry to achieve a wide input common-mode range and balanced input bias currents, regardless of input differential voltage or common-mode voltage, and circuitry to achieve ultra-low CMRR drift. The device also includes circuitry to enable output accuracy in the presence of pulse-width modulation (PWM) type input common-mode voltages. The AD8410A is available in 8-lead, SOIC\_N package and 8-lead, MSOP package.

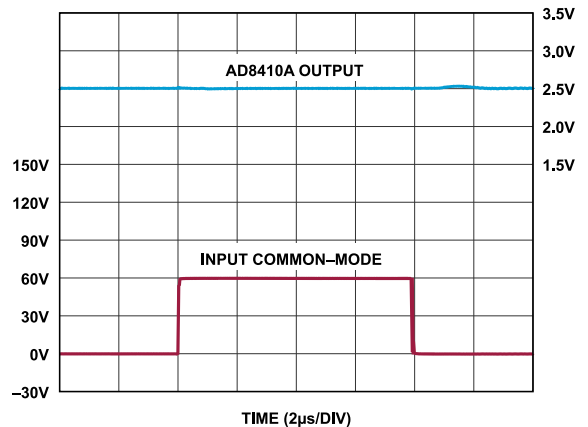

**Figure 2. Input Common-Mode Step Response (0 V to 60 V),  $V_S = 5 \text{ V}$ , Inputs Shorted**

<sup>1</sup> Protected by U.S. patent numbers 10,312,865 and 10,587,228.

**TABLE OF CONTENTS**

Features.....	1	Output Offset Adjustment.....	17
Applications.....	1	Unidirectional Operation.....	17
Typical Application Circuit.....	1	Bidirectional Operation.....	17
General Description.....	1	External Referenced Output.....	17
Functional Block Diagram.....	3	Splitting the Supply.....	18
Specifications.....	4	Splitting an External Reference.....	18
Absolute Maximum Ratings.....	6	Offset Voltage Terminology.....	19
Thermal Resistance.....	6	Applications Information.....	20
Electrostatic Discharge (ESD) Ratings.....	6	Motor Control.....	20
ESD Caution.....	6	Solenoid Control.....	21
Pin Configuration and Function Descriptions.....	7	Input Filter.....	21
Typical Performance Characteristics.....	8	Overcurrent Detection.....	22
Theory of Operation.....	15	Outline Dimensions.....	24
Current Sense Layout Guidelines.....	16	Ordering Guide.....	24
Choosing a Shunt Resistor.....	16	Evaluation Boards.....	24
Shunt Resistor Connection.....	16	Automotive Products.....	24

**REVISION HISTORY****7/2023—Rev. 0 to Rev. A**

Changes to Data Sheet Title.....	1
Changes to Features Section.....	1
Changes to General Description Section.....	1
Changes to Voltage Swing to GND (OUT - GND) Parameter and Voltage Swing to $V_S$ ( $V_S$ - OUT) Parameter, Table 1.....	4
Changes to Table 3.....	6
Added Table 5, Renumbered Sequentially.....	6
Changes to Figure 4 Caption.....	7
Changes to Typical Performance Characteristics Section.....	8
Added Figure 11, Renumbered Sequentially.....	9
Added Current Sense Layout Guidelines Section.....	16
Added Choosing a Shunt Resistor Section.....	16
Added Shunt Resistor Connection Section, Figure 48, and Figure 49.....	16
Changes to Box Method Section.....	19
Changes to Bowtie Method Section.....	19
Changes to Overcurrent Detection Section.....	22
Updated Outline Dimensions.....	24
Changes to Ordering Guide.....	24
Changes to Evaluation Boards.....	24
Added Automotive Products Section.....	24

**2/2023—Revision 0: Initial Version**

FUNCTIONAL BLOCK DIAGRAM

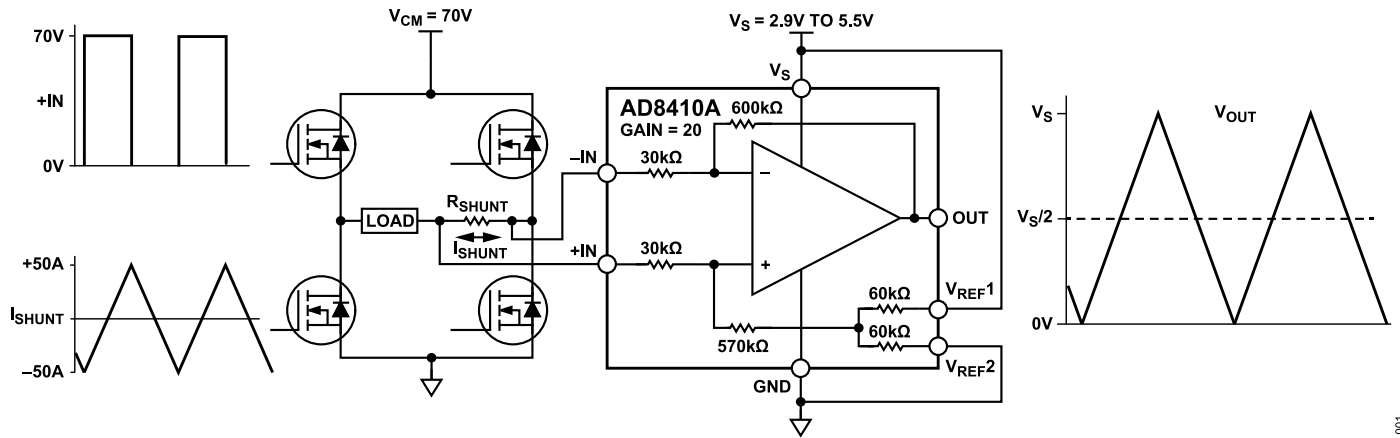

Figure 3. Functional Block Diagram

001

## SPECIFICATIONS

$T_A = -40^\circ\text{C}$  to  $+125^\circ\text{C}$  (operating temperature range), supply voltage ( $V_S$ ) = 5 V, ground (GND) = 0 V, Input Common-Mode Voltage ( $V_{CM}$ ) = -IN, +IN = 12 V, and  $V_{REF1} = V_{REF2} = 2.5$  V, unless otherwise noted.

Table 1. Electrical Specifications

Parameter	Test Conditions/Comments	Min	Typ	Max	Unit
GAIN					
Initial			20		V/V
Error Over Temperature	Specified temperature range			0.13	%
Gain vs. Temperature				±6	ppm/°C
VOLTAGE-OFFSET	Referred to input (RTI)				
Over Temperature	Specified temperature range <sup>1</sup>			±200	μV
Offset Drift	Box method (see Figure 56)		±0.21	±0.71	μV/°C
	Bowtie method (-40°C to 25°C) (see Figure 57)			±1.84	μV/°C
	Bowtie method (25°C to 125°C) (see Figure 57)			±1.51	μV/°C
INPUT					
Total Input-Bias Current <sup>2</sup>	+IN = -IN = 0 V, $V_S = V_{REF1} = 5$ V, $V_{REF2} = 0$ V	-10.0			μA
	+IN = -IN = 12 V, $V_S = V_{REF1} = V_{REF2} = 0$ V, $T_A = 25^\circ\text{C}$		44		μA
	+IN = -IN = 12 V, $V_S = V_{REF1} = 5$ V, $V_{REF2} = 0$ V			175	μA
	+IN = -IN = 48 V, $V_S = V_{REF1} = V_{REF2} = 0$ V, $T_A = 25^\circ\text{C}$		178		μA
	+IN = -IN = 48 V, $V_S = V_{REF1} = 5$ V, $V_{REF2} = 0$ V			484	μA
Input Offset Current	+IN = -IN = 0 V			1.0	μA
	+IN = -IN = 12 V			2.5	μA
	+IN = -IN = 48 V			2.7	μA
Input Voltage Range	Common mode, continuous	-2		+70	V
Common-Mode Rejection Ratio (CMRR)	Specified temperature range, DC, $V_{CM} = -2$ V to +70 V	123	142		dB
	$T_A = 25^\circ\text{C}$ , frequency = 10 kHz		110		dB
	$T_A = 25^\circ\text{C}$ , frequency = 50 kHz		96		dB
OUTPUT					
Voltage Swing to GND (OUT - GND)	Load resistance ( $R_L$ ) = 10 kΩ			5	mV
Voltage Swing to $V_S$ ( $V_S$ - OUT)	Load resistance ( $R_L$ ) = 10 kΩ			16	mV
Output Resistance	$T_A = 25^\circ\text{C}$		0.2		Ω
Maximum Capacitive-Load	No continuous oscillation, $T_A = 25^\circ\text{C}$		4.7		nF
DYNAMIC RESPONSE					
Small Signal, -3 dB Bandwidth	$T_A = 25^\circ\text{C}$		2.2		MHz
Slew Rate	$T_A = 25^\circ\text{C}$		10		V/μs
NOISE					
0.1 Hz to 10 Hz (RTI)	$T_A = 25^\circ\text{C}$		8		μV p-p
Spectral Density, 1 kHz (RTI)	$T_A = 25^\circ\text{C}$		47		nV/√Hz
Spectral Density, 10 kHz (RTI)	$T_A = 25^\circ\text{C}$		38		nV/√Hz
OFFSET ADJUSTMENT					
Ratiometric Accuracy <sup>3</sup>	$V_{REF}$ pins divider to supply	0.499		0.501	V/V
Accuracy, Referred to the Output (RTO)	$V_{REF}$ error when using an external reference of 2.5 V applied to $V_{REF1}$ and $V_{REF2}$ in parallel			±1	mV/V
$V_{REF1,2}$ Input Voltage Range		GND		$V_S$	V
$V_{REF1,2}$ Divider Resistor Values			60		kΩ
POWER SUPPLY					
Operating Voltage Range		2.9		5.5	V
Quiescent Current	Output voltage ( $V_{OUT}$ ) = 2.5 V DC, $T_A = 25^\circ\text{C}$		7.8		mA
	$V_{OUT} = 2.5$ V DC			10.8	mA
Power Supply Rejection Ratio (PSRR)	$V_S$ from 3 V to 5 V, Specified temperature range	84	120		dB

**SPECIFICATIONS****Table 1. Electrical Specifications (Continued)**

Parameter	Test Conditions/Comments	Min	Typ	Max	Unit
TEMPERATURE RANGE					
For Specified Performance	Operating temperature range	-40		+125	°C

<sup>1</sup> Guaranteed by test and characterization

<sup>2</sup> To see input bias current per pin, see [Figure 14](#) and [Figure 15](#).

<sup>3</sup> The offset adjustment is ratiometric to the power supply when  $V_{REF1}$  and  $V_{REF2}$  are used as dividers between the supplies.

## ABSOLUTE MAXIMUM RATINGS

**Table 2. Absolute Maximum Ratings**

Parameter	Rating
Supply Voltage ( $V_S$ to GND)	6 V
Input Voltage Range, Continuous	
Common-Mode	
+IN to GND	-20 V to +85 V
-IN to GND	-20 V to +85 V
Differential	
+IN to -IN	± 20 V
$V_{REF1}$ , $V_{REF2}$	GND - 0.3 V to $V_S + 0.3$ V
Reverse Supply Voltage	0.3 V
Temperature	
Operating Range	-40°C to +125°C
Storage Range	-65°C to +150°C
Output Short-Circuit Duration	Indefinite

Stresses at or above those listed under Absolute Maximum Ratings may cause permanent damage to the product. This is a stress rating only; functional operation of the product at these or any other conditions above those indicated in the operational section of this specification is not implied. Operation beyond the maximum operating conditions for extended periods may affect product reliability.

## THERMAL RESISTANCE

Thermal performance is directly linked to printed circuit board (PCB) design and operating environment. Careful attention to PCB thermal design is required.

$\theta_{JA}$  is the natural convection, junction-to-ambient thermal resistance measured in a one cubic foot sealed enclosure.  $\theta_{JB}$  is the junction-to-board thermal resistance.  $\theta_{JCT}$  is the junction-to-case thermal resistance.

**Table 3. Thermal Resistance**

Package Type <sup>1</sup>	$\theta_{JA}$	$\theta_{JB}$	$\theta_{JCT}$	Unit
R-8	142.8	140.6	64.1	°C/W
RM-8	152	120.6	59.7	°C/W

<sup>1</sup> Thermal impedance simulated values are based on a JEDEC 2S2P thermal test board for  $\theta_{JA}$ , JEDEC 2S2P thermal impedance with ring style cold plate attached to PCB for  $\theta_{JB}$ , and a JEDEC 1S0P thermal test board for  $\theta_{JCT}$ . See JEDEC JESD-51.

## ELECTROSTATIC DISCHARGE (ESD) RATINGS

The following ESD information is provided for handling of ESD-sensitive devices in an ESD protected area only.

Human body model (HBM) per ANSI/ESDA/JEDEC JS-001.

Field-induced robotic charged device model (FICDM) per ANSI/ESDA/JEDEC JS-002.

## ESD Ratings for AD8410A

**Table 4. AD8410A, 8-Lead SOIC\_N**

ESD Model	Withstand Threshold (V)	Class
HBM	±4000	3A
FICDM	±750	C2B

**Table 5. AD8410A, 8-Lead MSOP**

ESD Model	Withstand Threshold (V)	Class
FICDM	±750	C2B

## ESD CAUTION



**ESD (electrostatic discharge) sensitive device.** Charged devices and circuit boards can discharge without detection. Although this product features patented or proprietary protection circuitry, damage may occur on devices subjected to high energy ESD. Therefore, proper ESD precautions should be taken to avoid performance degradation or loss of functionality.

## PIN CONFIGURATION AND FUNCTION DESCRIPTIONS

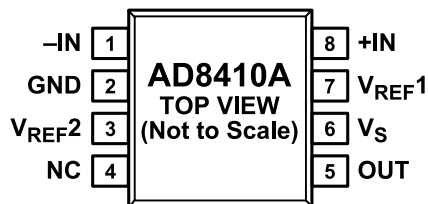

## NOTES

1. NC = NO CONNECT. THIS PIN IS CONNECTED INTERNALLY TO THE DIE. IT CAN BE LEFT FLOATING OR TIED TO GND.

100

Figure 4. 8-Lead MSOP and 8-Lead SOIC Pin Configuration

Table 6. Pin Function Descriptions

Pin Number	Mnemonic	Description
1	-IN	Negative Input.
2	GND	Ground.
3	V <sub>REF2</sub>	Reference Input 2.
4	NC	No Connect. This pin is connected internally to the die. It can be left floating or tied to GND.
5	OUT	Output.
6	V <sub>S</sub>	Supply Voltage.
7	V <sub>REF1</sub>	Reference Input 1.
8	+IN	Positive Input.

TYPICAL PERFORMANCE CHARACTERISTICS

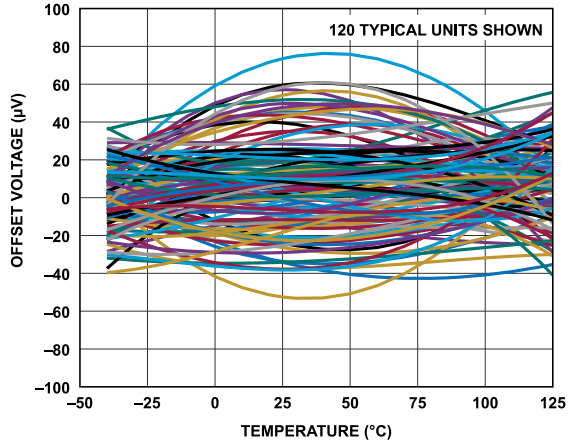

Figure 5. Offset Voltage vs. Temperature

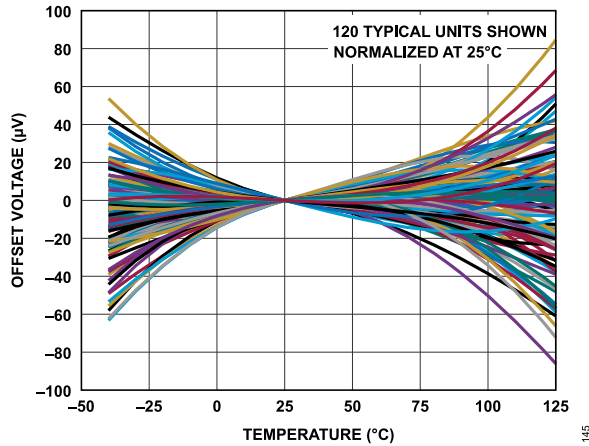

Figure 6. Offset Voltage vs. Temperature, Normalized at 25°C

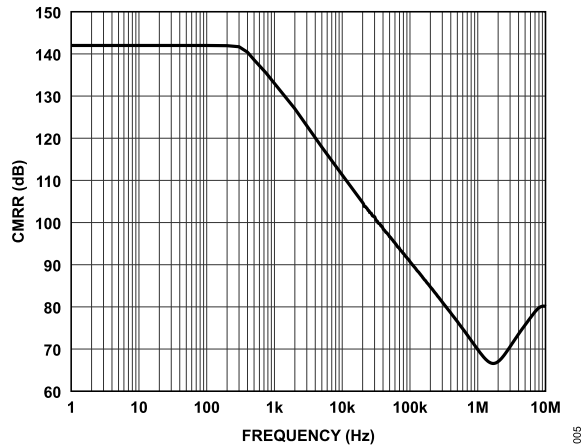

Figure 7. CMRR vs. Frequency

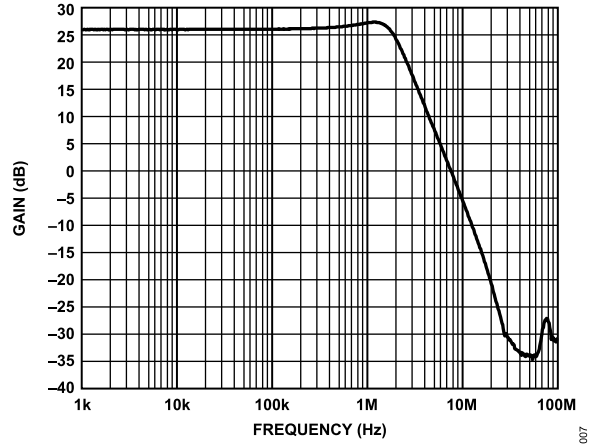

Figure 8. Typical Small Signal Bandwidth,  $V_{OUT} = 200\text{ mV p-p}$

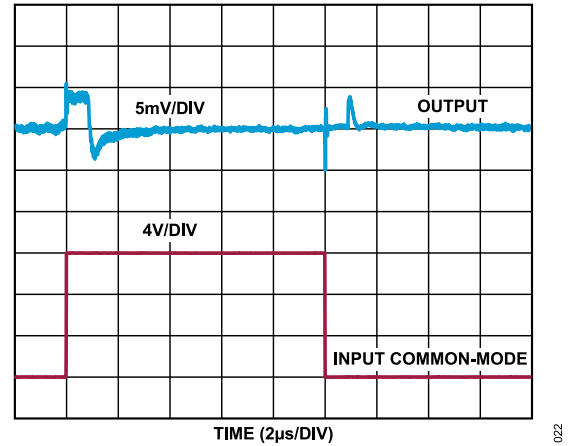

Figure 9. Input Common-Mode Step Response (0 V to 12 V),  $V_S = 5\text{ V}$ , Inputs Shorted

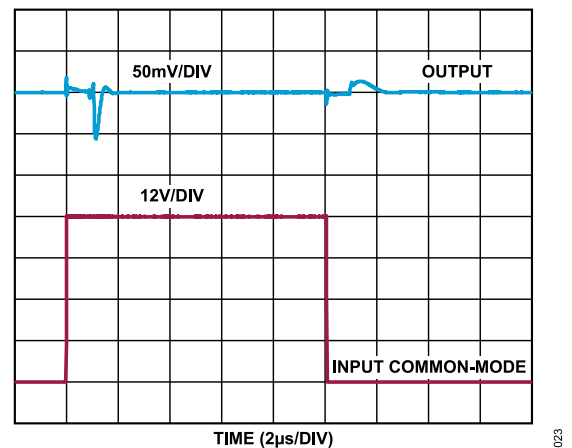

Figure 10. Input Common-Mode Step Response (0 V to 48 V),  $V_S = 5\text{ V}$ , Inputs Shorted



TYPICAL PERFORMANCE CHARACTERISTICS

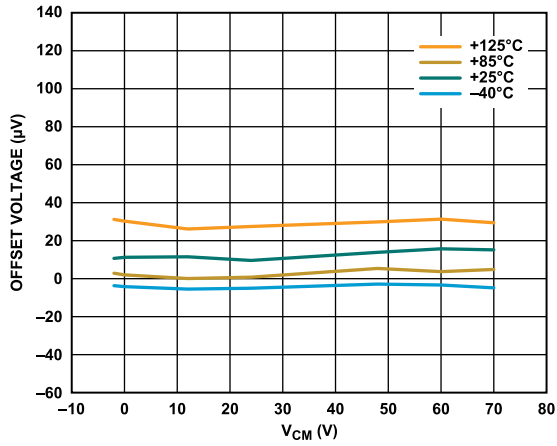

Figure 11. Offset Voltage vs. Common-Mode Voltage

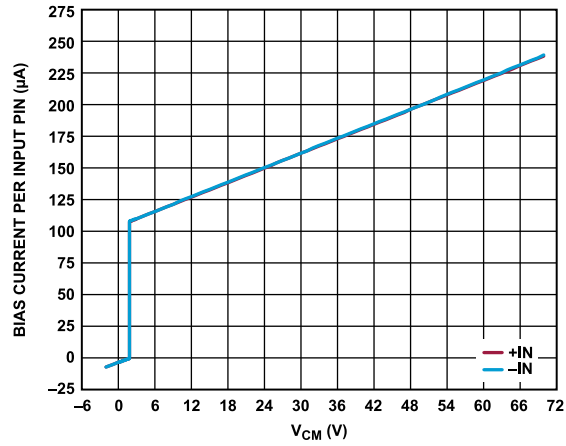

Figure 14. Bias Current Per Input Pin vs.  $V_{CM}$ ,  $V_S = 5 V$

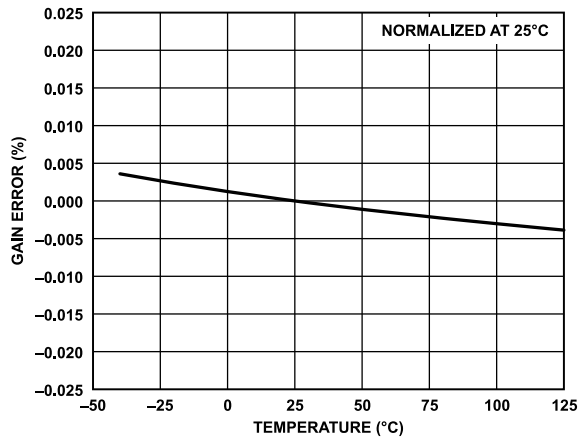

Figure 12. Gain Error vs. Temperature

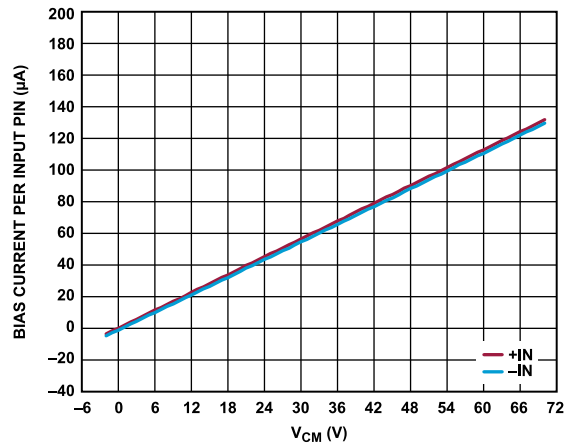

Figure 15. Bias Current Per Input Pin vs.  $V_{CM}$ ,  $V_S = 0 V$ ,  $R_L = 10 k\Omega$

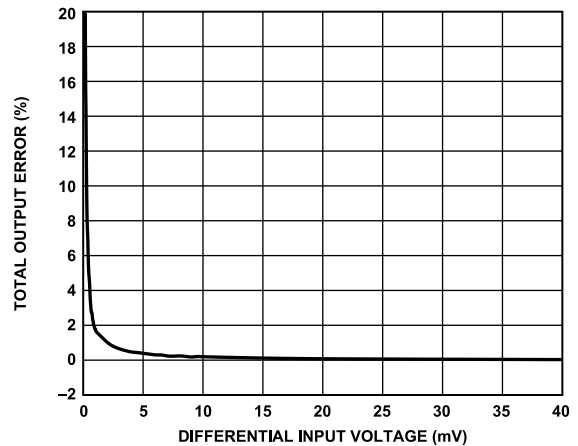

Figure 13. Total Output Error vs. Differential Input Voltage

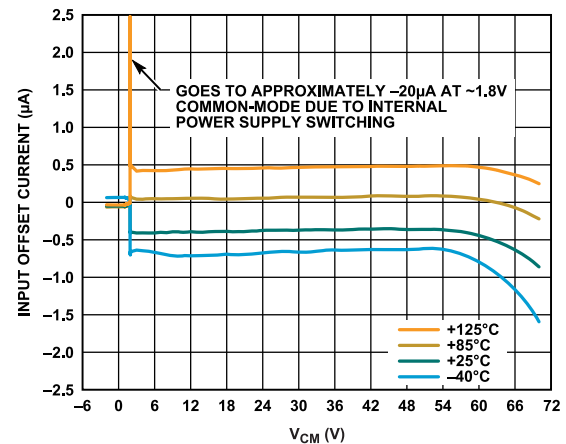

Figure 16. Input Offset Current vs.  $V_{CM}$  at Various Temperatures

TYPICAL PERFORMANCE CHARACTERISTICS

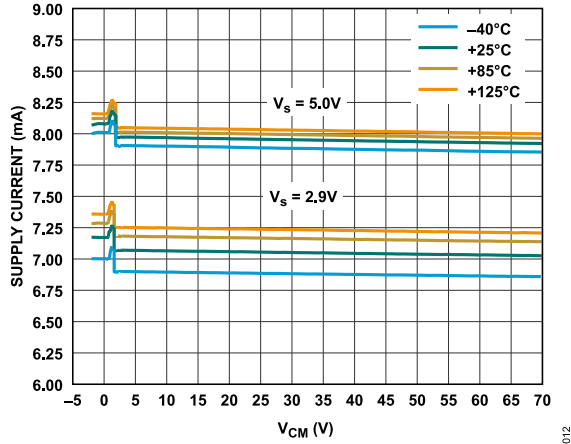

Figure 17. Supply Current vs. Input  $V_{CM}$  at Various Temperatures and Supply Voltages

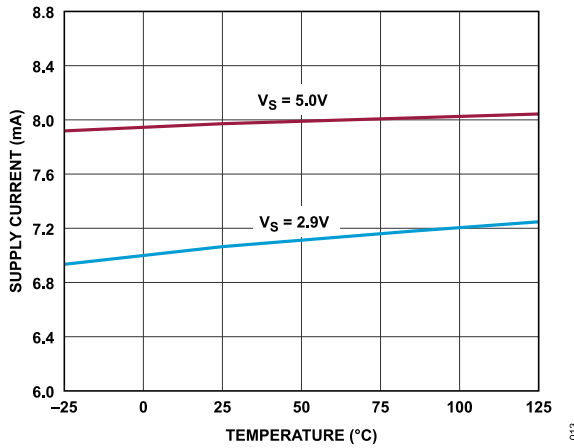

Figure 18. Supply Current vs. Temperature at Various Supply Voltages

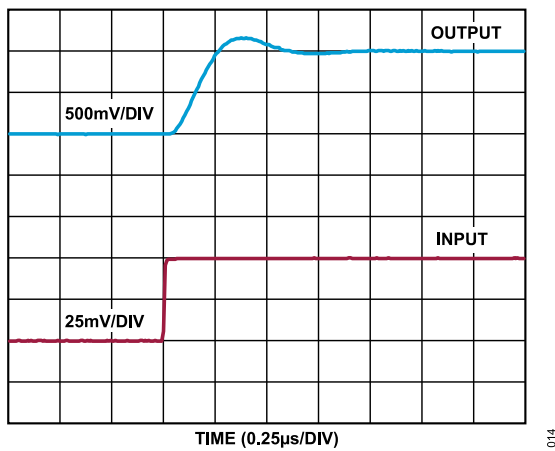

Figure 19. Rise Time,  $V_S = 2.9 V$

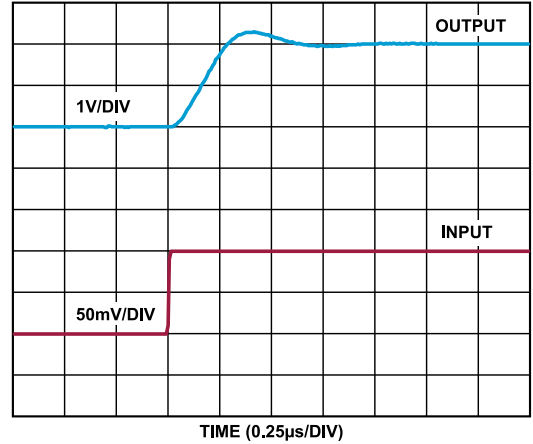

Figure 20. Rise Time,  $V_S = 5 V$

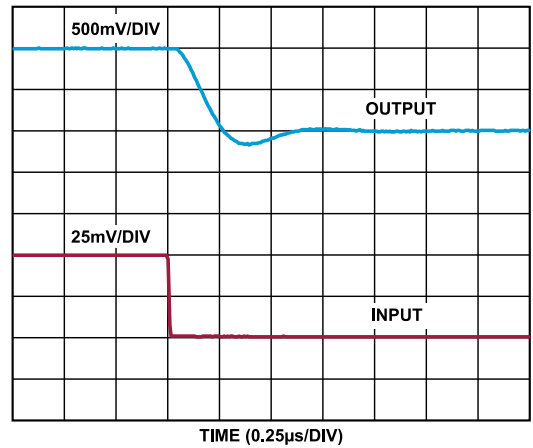

Figure 21. Fall Time,  $V_S = 2.9 V$

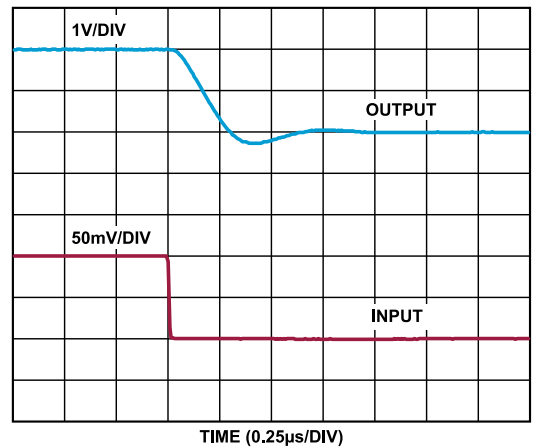

Figure 22. Fall Time,  $V_S = 5 V$

TYPICAL PERFORMANCE CHARACTERISTICS

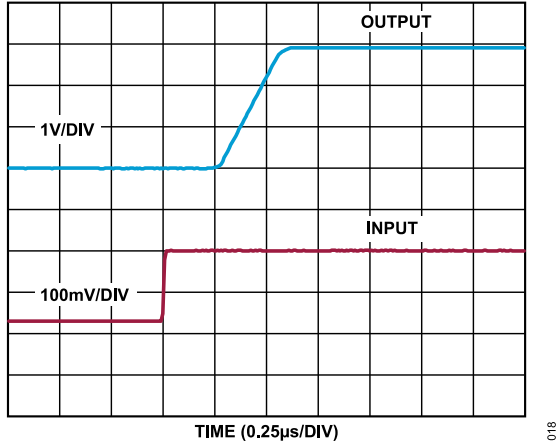

Figure 23. Differential Overload Recovery, Rising,  $V_S = 2.9\text{ V}$

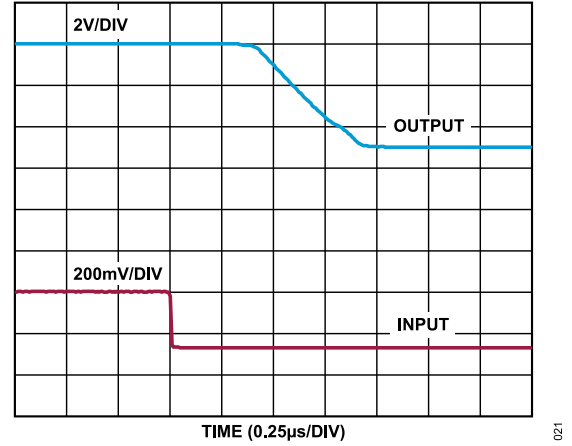

Figure 26. Differential Overload Recovery, Falling,  $V_S = 5\text{ V}$

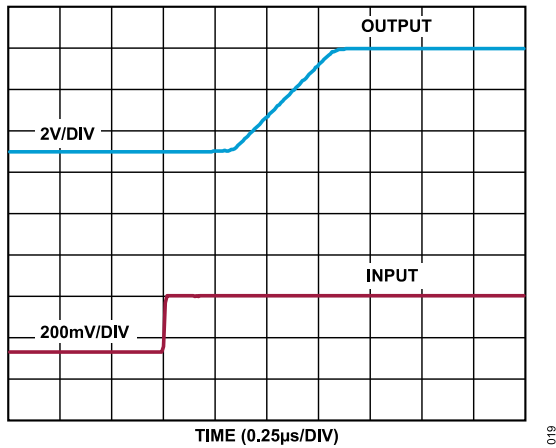

Figure 24. Differential Overload Recovery, Rising,  $V_S = 5\text{ V}$

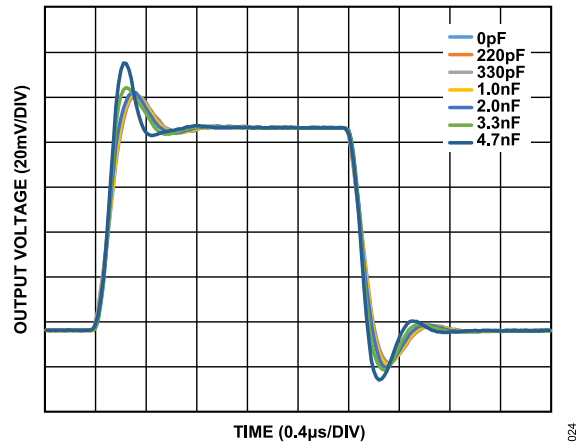

Figure 27. Small Signal Response for Various Capacitive Loads

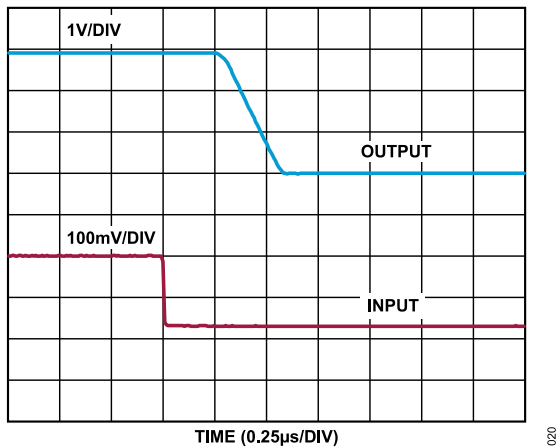

Figure 25. Differential Overload Recovery, Falling,  $V_S = 2.9\text{ V}$

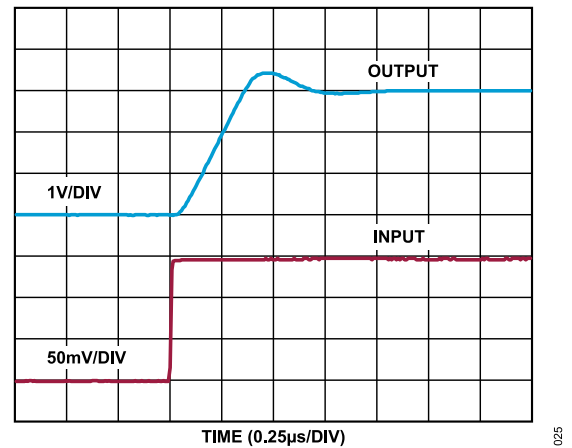

Figure 28. Large Signal Response, Rising,  $V_S = 5\text{ V}$

TYPICAL PERFORMANCE CHARACTERISTICS

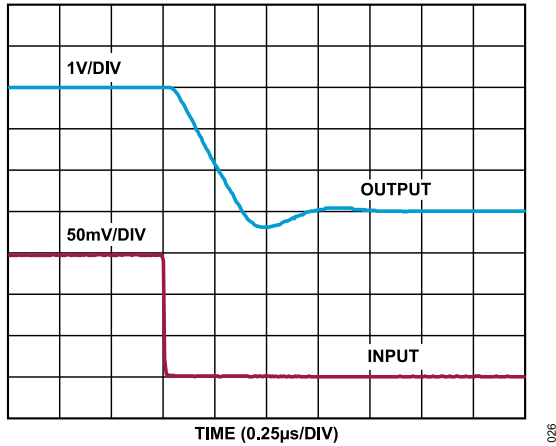

Figure 29. Large Signal Response, Falling,  $V_S = 5\text{ V}$

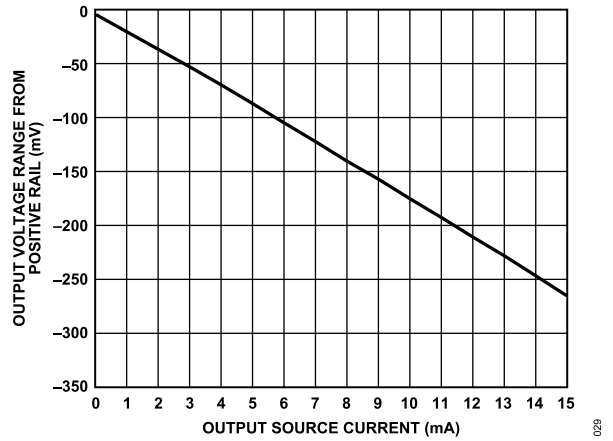

Figure 32. Output Voltage Range from Positive Rail vs. Output Source Current

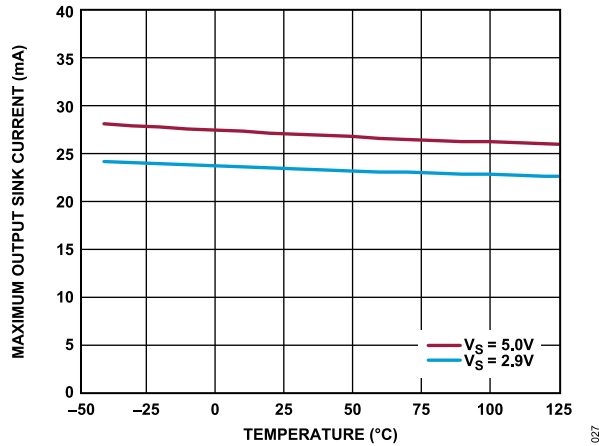

Figure 30. Maximum Output Sink Current vs. Temperature at Various Supply Voltages

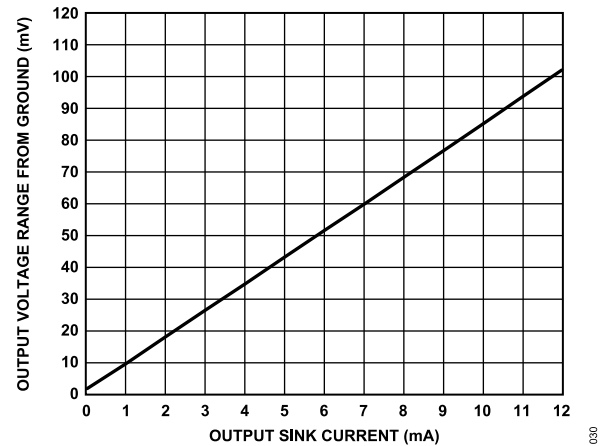

Figure 33. Output Voltage Range from Ground vs. Output Sink Current

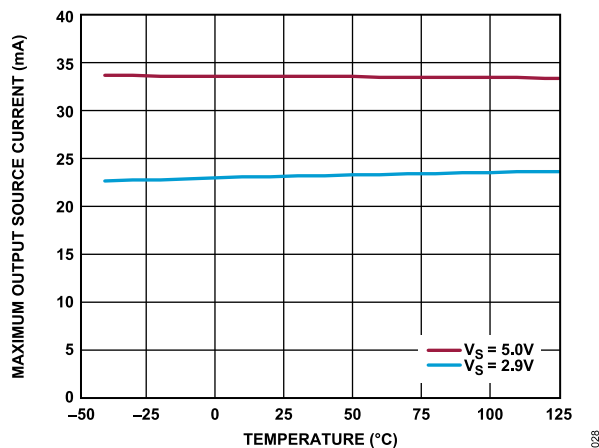

Figure 31. Maximum Output Source Current vs. Temperature at Various Supply Voltages

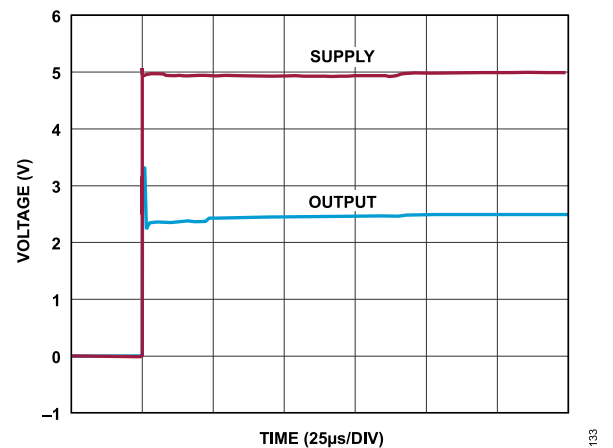

Figure 34. Start-Up Response

TYPICAL PERFORMANCE CHARACTERISTICS

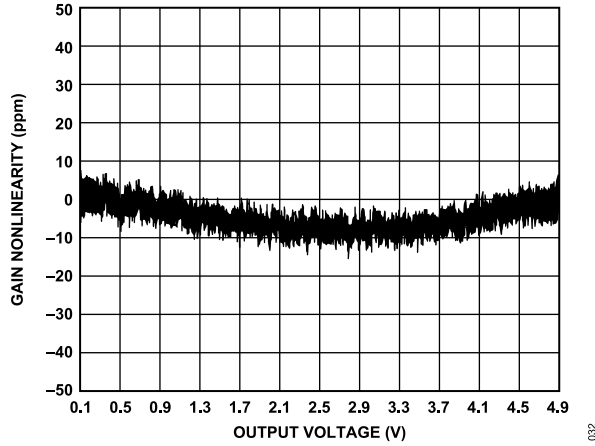

Figure 35. Gain Nonlinearity vs. Output Voltage,  $V_S = 5\text{ V}$

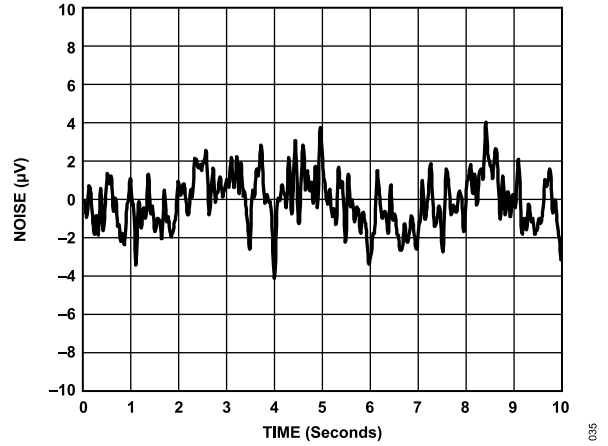

Figure 38. 0.1 Hz to 10 Hz Noise, RTI

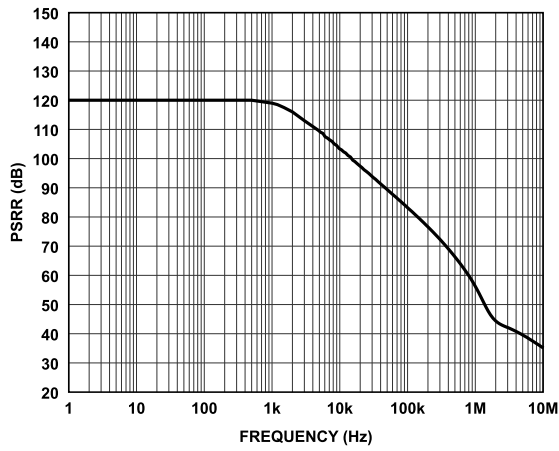

Figure 36. PSRR vs. Frequency

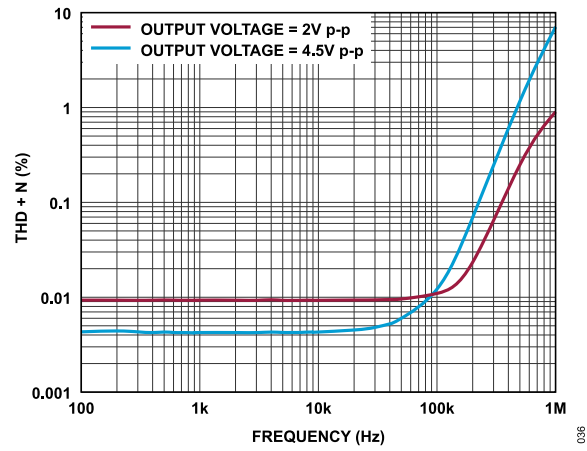

Figure 39. Total Harmonic Distortion + Noise (THD + N) vs. Frequency

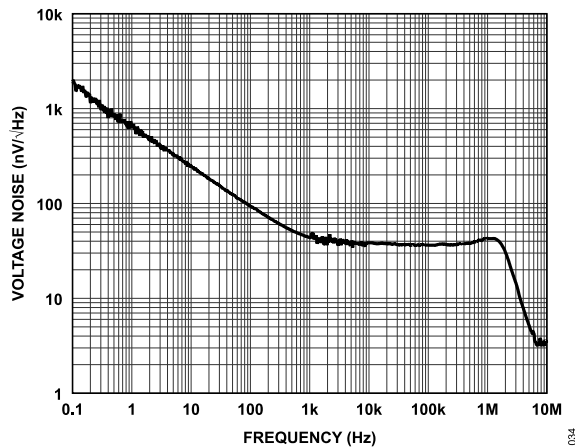

Figure 37. Spectral Density, RTI

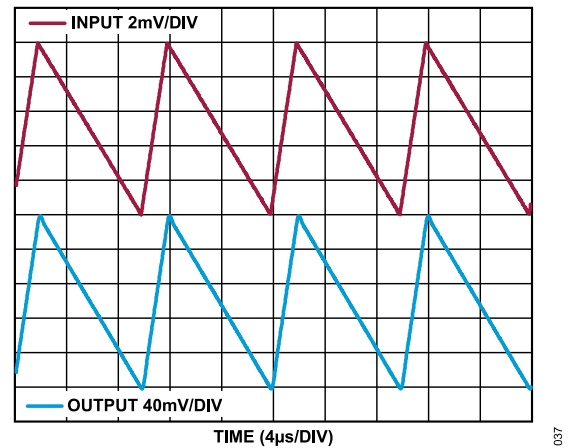

Figure 40. Output Response for 100 kHz, 20% Duty-Cycle, Sawtooth Waveform, Input Voltage ( $V_{IN}$ ) = 10 mV p-p

TYPICAL PERFORMANCE CHARACTERISTICS

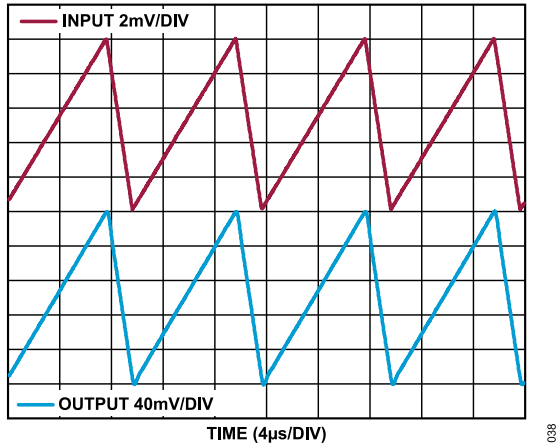

Figure 41. Output Response for 100 kHz, 80% Duty-Cycle, Sawtooth Waveform, Input Voltage ( $V_{IN}$ ) = 10 mV p-p

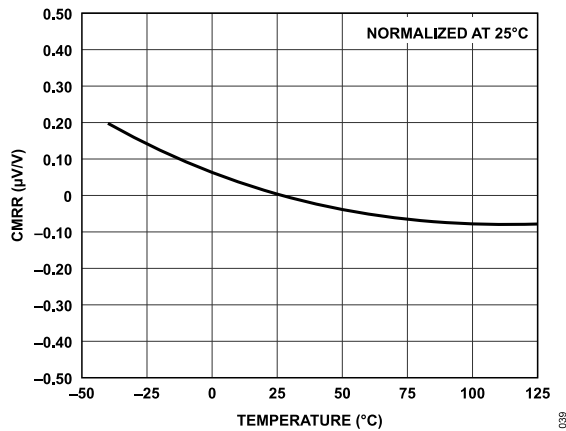

Figure 42. CMRR vs. Temperature

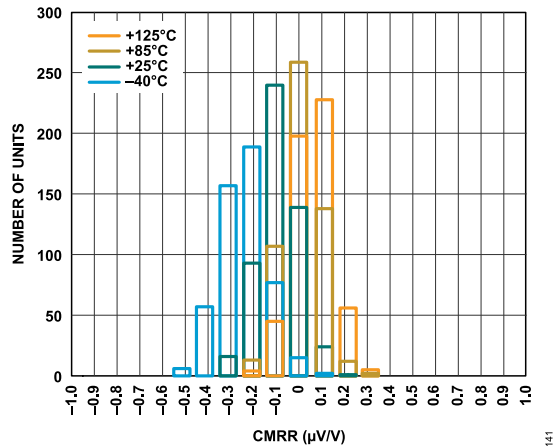

Figure 43. CMRR Distribution

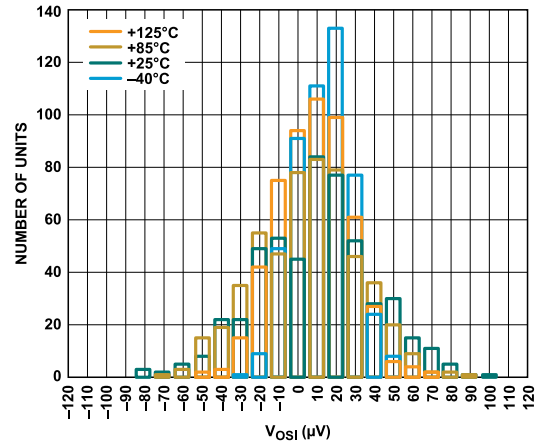

Figure 44. Offset Voltage ( $V_{OS}$ ) Distribution, RTI

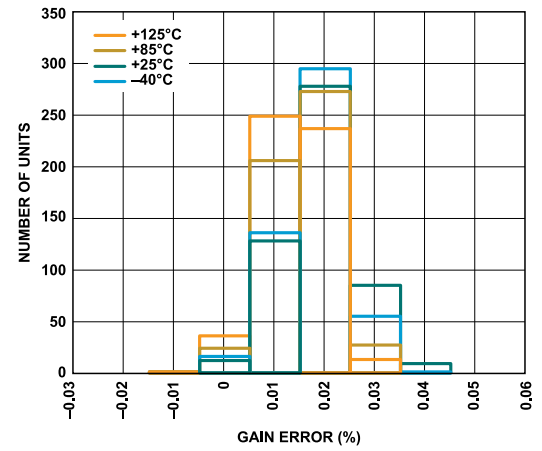

Figure 45. Gain Error Distribution

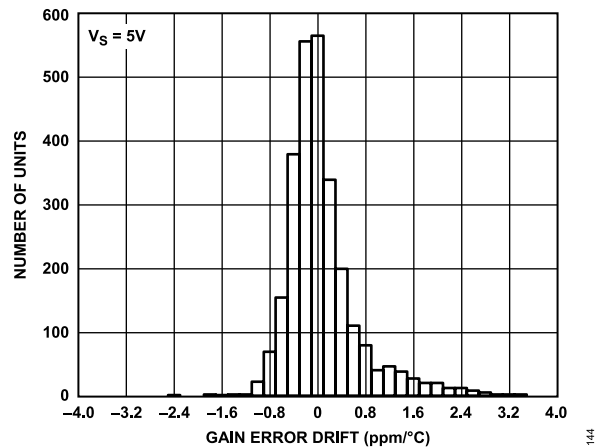

Figure 46. Gain Error Drift Distribution

## THEORY OF OPERATION

The AD8410A is a wide input voltage range, high bandwidth current-sense amplifier with PWM rejection that uses a unique architecture to accurately amplify the small differential current shunt voltages in the presence of rapidly changing common-mode voltages.

In typical applications, the AD8410A measures the current by amplifying the voltage across a shunt resistor connected to the inputs by a gain of 20 V/V (see Figure 47).

The AD8410A design provides excellent common-mode rejection, even with PWM common-mode inputs that can change at fast rates, such as 1 V/ns. The AD8410A has internal deglitch circuitry that helps to reduce the negative effects (such as the amplitude and settling time) of the output response in the presence of common-mode PWM input signals typically found in the applications for current-sense amplifiers. When there is a large common-mode transient at the input of the AD8410A, the output of the AD8410A is held at the last value for about 1  $\mu$ s. This allows the change in the amplitude of the output of the AD8410A after a VCM step to remain low and undisturbed. After the typical 1  $\mu$ s deglitch time, the output begins to settle to the appropriate value based on the differential voltage across the shunt resistor at the inputs (see Figure 9 and Figure 10).

The AD8410A features an in-package trim core, which leads to a typical offset drift of  $\pm 0.21 \mu\text{V}/^\circ\text{C}$  throughout the operating temperature range and the common-mode voltage range without the need for chopping and autozero clocks (which could lead to intermodulation in the application). This architecture does not compromise bandwidth, which is typically rated at 2.2 MHz.

The reference input pins,  $V_{\text{REF}1}$  and  $V_{\text{REF}2}$ , are tied through 60 k $\Omega$  resistors to the positive input of the main amplifier, which allows the output offset to be adjusted anywhere in the output operating range. The gain is 1 V/V from the reference pins to the output when the reference pins are used in parallel. When the reference pins are used to divide the supply, the gain is 0.5 V/V.

The AD8410A offers breakthrough performance without compromising the robust application needs typical of solenoid control, motor control, or DC-DC converters. The ability to reject PWM input common-mode voltages, and the DigiTrim architecture providing low offset and offset drift, allows the AD8410A to deliver total accuracy for these demanding applications.

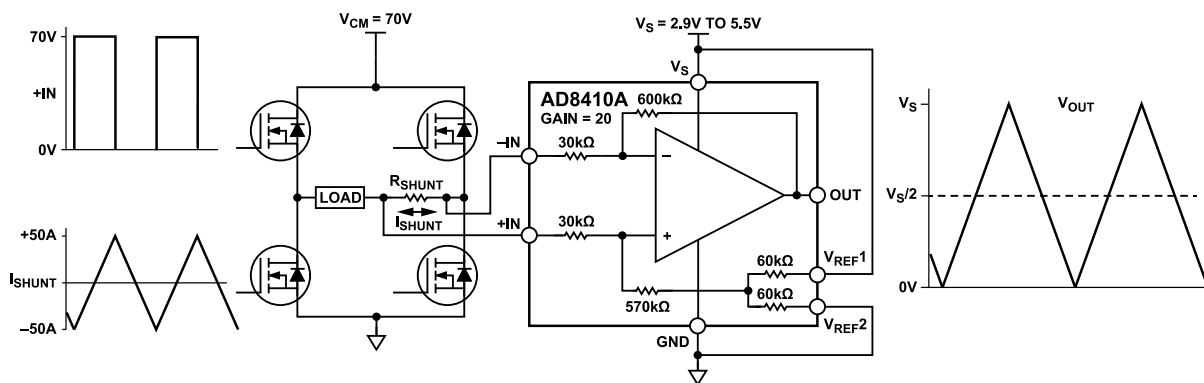

Figure 47. Typical Application

04

## CURRENT SENSE LAYOUT GUIDELINES

### CHOOSING A SHUNT RESISTOR

There are different factors to consider in selecting the appropriate shunt resistor, including the resistor value, size, cost, tolerance, power dissipation, and thermal drift.

Commonly, the resistor value is selected based upon the desired maximum differential voltage generated at the highest expected current, while considering the power loss budget. Another consideration is to ensure the output is maximized at full-scale current, taking full advantage of the available system dynamic range. Choosing the shunt resistor,  $R_{SHUNT}$ , value is often a compromise between these two considerations.

$$R_{SHUNT} = V_{DIFF, MAX} / I_{MAX} \quad (1)$$

The shunt resistor tolerance directly affects the accuracy of the overall gain error of the current measurement. The AD8410A is specified to have a maximum gain error of 0.13% over the specified temperature range from  $-40^{\circ}\text{C}$  to  $+125^{\circ}\text{C}$ . For optimal performance, select a 0.1% shunt resistor (or with lower tolerance) that does not introduce more gain error than the AD8410A.

The power dissipation in the shunt resistor is calculated using the equation:  $P = I^2R$ . Thus, a higher resistance results in higher power dissipation. Power dissipation in the shunt resistor leads to self heating, resulting in an increase in the temperature of the shunt resistor. Any change in shunt resistor temperature due to self heating can result in a nonlinear error. Selecting a shunt resistor with a low temperature coefficient minimizes any self heating of the shunt and minimizes any thermal nonlinearities.

The thermal drift of the voltage developed across the shunt resistor varies in relationship to the power dissipated by the resistor.

### SHUNT RESISTOR CONNECTION

The shunt resistor,  $R_{SHUNT}$ , is connected between the input pins of the current sense amplifier, which is shown in Figure 48. Typically, the shunt resistor has very low resistance. Thus, it is recommended to use a Kelvin (4-wire) connection on the shunt to achieve high accuracy current sense measurement. A proper Kelvin connection avoids sensing across any parasitic PCB trace resistance.

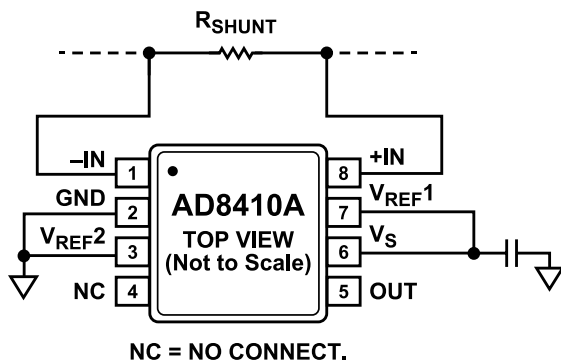

248

Figure 48. Shunt Resistor Layout

There are different ways to make the Kelvin connection to the  $R_{SHUNT}$  resistor. Figure 49 shows a test board of five different layouts to verify which is the best layout to optimize high-current sensing accuracy. Based on the *Analog Dialogue* article, "Optimize High-Current Sensing Accuracy by Improving Pad Layout of Low-Value Shunt Resistors" (Volume 46, June 2012), the sense points must be considered by placing them at the outer extremity of the resistor. The article shows that it was experimentally determined that the layouts with the lowest errors are Style C and Style D. Layout Style C is preferred because component placement tolerance issues are less likely to arise. Without a Kelvin connection, measuring on the top pad, there is about a 22.8% error. Therefore, it is better to use a Kelvin connection when using a low-value  $R_{SHUNT}$  to obtain more accurate current sense measurements.

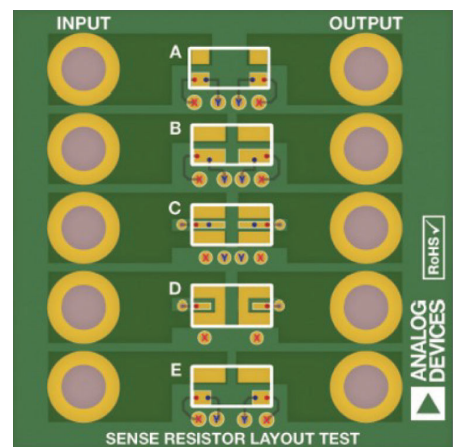

Figure 49. Sample  $R_{SHUNT}$  Layout Board



## OUTPUT OFFSET ADJUSTMENT

The output of the AD8410A can be adjusted for unidirectional or bidirectional operation.

### UNIDIRECTIONAL OPERATION

Unidirectional operation allows the AD8410A to measure currents through a resistive shunt in one direction. The basic modes for unidirectional operation are ground referenced output mode and  $V_S$  referenced output mode.

For unidirectional operation, the output can be set at the negative rail (near ground) or at the positive rail (near  $V_S$ ) when the differential input is 0 V. The output moves to the opposite rail when a correct polarity differential input voltage is applied. The required polarity of the differential input depends on the output voltage setting. If the output is set at the positive rail, the input polarity must be negative to decrease the output. If the output is set at ground, the polarity must be positive to increase the output.

#### Ground Referenced Output Mode

When using the AD8410A in ground referenced output mode, both referenced inputs are tied to the GND pin, which causes the output to sit at the negative rail when there are zero differential volts at the input (see Figure 50).

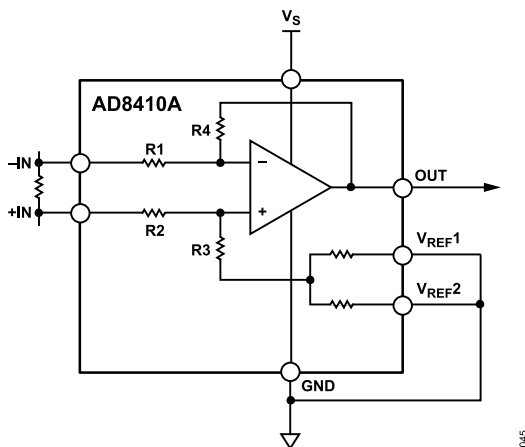

Figure 50. Ground Referenced Output

#### $V_S$ Referenced Output Mode

$V_S$  referenced output mode is set when both reference pins are tied to the positive supply. This mode is typically used when the diagnostic scheme requires detection of the amplifier and the wiring before power is applied to the load (see Figure 51).

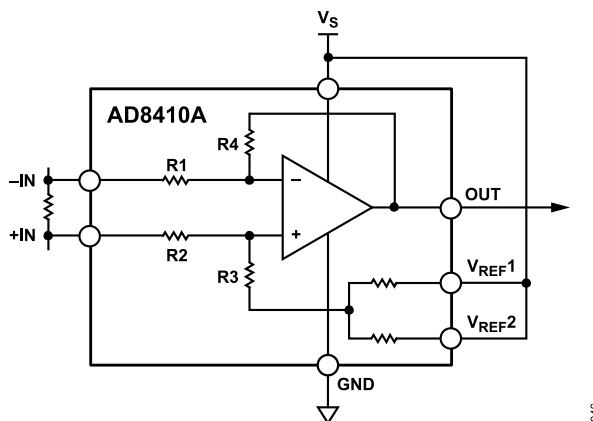

Figure 51.  $V_S$  Referenced Output

### BIDIRECTIONAL OPERATION

Bidirectional operation allows the AD8410A to measure the currents through a resistive shunt in two directions.

In this case, the output is set anywhere within the output range. Typically, the output is set at half-scale for an equal range in both directions. In some cases, however, the output is set at a voltage other than half-scale when the bidirectional current is nonsymmetrical.

Adjusting the output is accomplished by applying DC voltage to the reference inputs.  $V_{REF1}$  and  $V_{REF2}$  are tied to internal resistors that connect to an internal node. There is no operational difference between the reference pins.

#### EXTERNAL REFERENCED OUTPUT

Tie  $V_{REF1}$  and  $V_{REF2}$  together and to a reference to produce an output equal to the reference voltage when there is no differential input (see Figure 52). The output decreases with respect to the reference voltage when the input is negative, relative to the  $-IN$  pin, and increases when the input is positive, relative to the  $-IN$  pin.

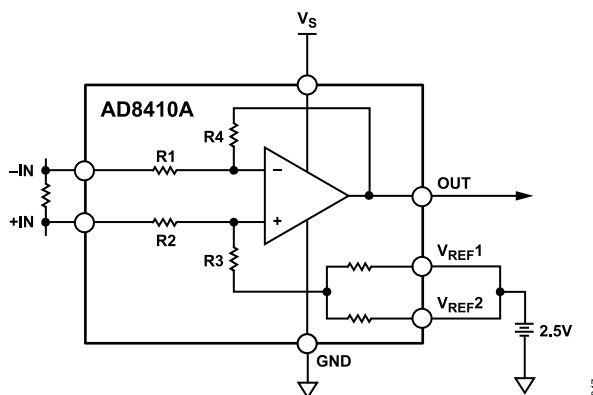

Figure 52. External Referenced Output

## OUTPUT OFFSET ADJUSTMENT

### SPLITTING THE SUPPLY

By tying one reference pin to the  $V_S$  pin and the other reference pin to the GND pin, the output is set at half of the supply when there is no differential input (see Figure 53). The benefit of this configuration is that an external reference is not required to offset the output for bidirectional current measurement. Tying one reference pin to the  $V_S$  pin and the other reference pin to the GND pin creates a midscale offset that is ratiometric to the supply, which means that if the supply increases or decreases, the output remains at half the supply. For example, if the supply is 5.0 V, the output is at half-scale or 2.5 V. If the supply increases by 10% (to 5.5 V), the output increases to 2.75 V.

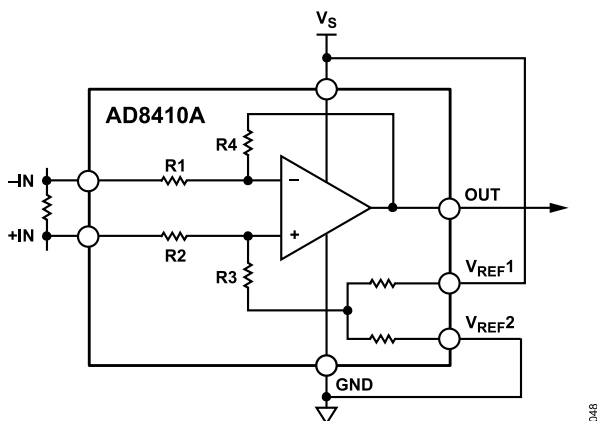

Figure 53. Split Supply

048

### SPLITTING AN EXTERNAL REFERENCE

Use the internal reference resistors to divide an external reference by 2 with an accuracy of approximately 0.5%. Split an external reference by connecting one  $V_{REFX}$  pin to the GND pin and the other  $V_{REFX}$  pin to the reference voltage (see Figure 54).

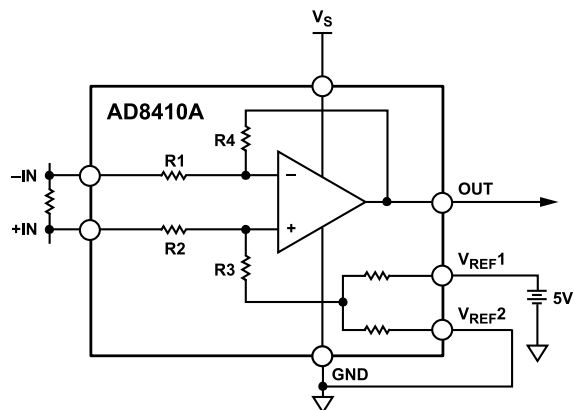

Figure 54. Split External Reference

049

OFFSET VOLTAGE TERMINOLOGY

BOX METHOD

The AD8410A features an in-package trim core, which leads to a typical offset drift of  $\pm 0.21 \mu\text{V}/^\circ\text{C}$  (using the Box Method) throughout the operating temperature range and the common-mode voltage range. This architecture does not compromise bandwidth, but the offset voltage drift signatures for the AD8410A vary part to part as shown in the Figure 55. After observing the minimum and maximum value for  $V_{OS}$  over the full temperature range from  $-40^\circ\text{C}$  to  $125^\circ\text{C}$ , the  $V_{OS}$  in  $\mu\text{V}/^\circ\text{C}$  is calculated for each part using the box method.

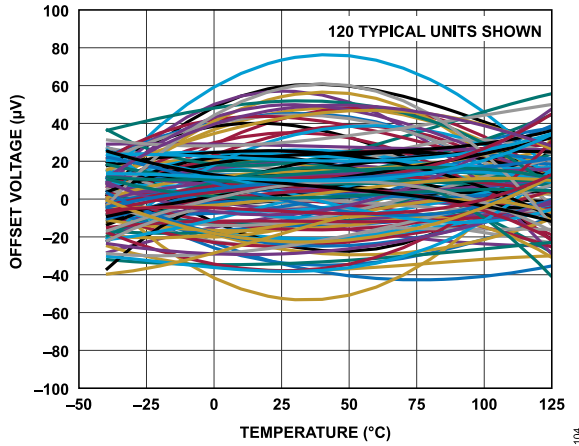

Figure 55. Offset Voltage vs. Temperature

A visual representation of this box method calculation and the mean value for the  $V_{OS}$  drift using the box method is shown in Figure 56. Based on the mean (Typ) value of  $\pm 0.21 \mu\text{V}/^\circ\text{C}$  and the standard deviation of the box method drift of the 120 parts from Figure 55, a user can calculate a value (see Equation 2) for a guarantee  $V_{OS}$  drift by characterization,  $\pm 0.71 \mu\text{V}/^\circ\text{C}$ .

$$\pm (MEAN + 5 \times (STANDARD DEVIATION)) \quad (2)$$

This is valid from  $-40^\circ\text{C}$  to  $125^\circ\text{C}$  temperature range.

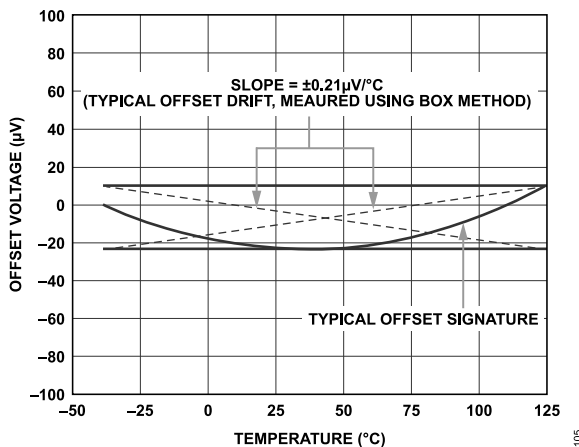

Figure 56. Box Method

BOWTIE METHOD

Typically, in the applications where the AD8410A is used, a calibration is done at  $25^\circ\text{C}$ . If a single point calibration at  $25^\circ\text{C}$  is done on the 120 parts as shown in Figure 55, this creates a plot shown in Figure 57. For each part, the slope of the line from  $25^\circ\text{C}$  to  $-40^\circ\text{C}$  is calculated and the slope from  $25^\circ\text{C}$  to  $125^\circ\text{C}$  for each part is calculated. The mean and standard deviation for the slope of all the parts from  $25^\circ\text{C}$  to  $-40^\circ\text{C}$  is then calculated. The  $V_{OS}$  max drift of  $\pm 1.85 \mu\text{V}/^\circ\text{C}$  using the bowtie method is then calculated using Equation 2. The mean and standard deviation for the slope of all the parts from  $25^\circ\text{C}$  to  $125^\circ\text{C}$  is then calculated. The  $V_{OS}$  max drift of  $1.51 \mu\text{V}/^\circ\text{C}$  using the bowtie method is then calculated using Equation 2. The red lines in Figure 57 represent the worst-case  $V_{OS}$  drift slopes using the bowtie method that a user can guarantee through characterization. Calibrating at  $25^\circ\text{C}$  allows the max  $V_{OS}$  over the full temp range to be reduced to  $\sim \pm 151 \mu\text{V}$ , as opposed to the  $\pm 200 \mu\text{V}$  listed in the Specifications section as the max  $V_{OS}$  over temperature (with no calibration).

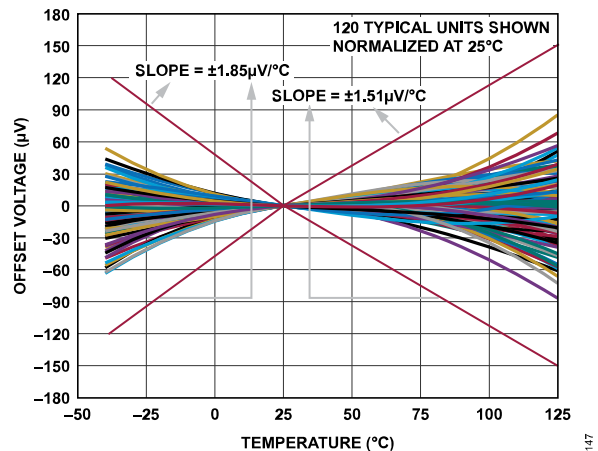

Figure 57. Bowtie Method

## APPLICATIONS INFORMATION

## MOTOR CONTROL

## 3-Phase Motor Control

The AD8410A is ideally suited for monitoring current in 3-phase motor applications such as brushless DC motors.

The 2.2 MHz typical bandwidth of the AD8410A provides instantaneous current monitoring. Additionally, the typical low offset drift of  $\pm 0.21 \mu\text{V}/^\circ\text{C}$  means that the measurement error between the two motor phases is at a minimum over temperature. The AD8410A rejects PWM input common-mode voltages in the  $-2 \text{ V}$  to  $+70 \text{ V}$  range. Monitoring the current on the motor phase allows sampling of the current at any point and provides diagnostic information, such as a short to ground and battery. The DigiTrim architecture used in the AD8410A provides precision specifications without the need for chopping and/or auto-zeroing. The DigiTrim architecture of the AD8410A avoids the potential for intermodulation distortion, which is observed when using amplifiers with chopping/auto-zero architectures. For the typical phase current measurement setup with the AD8410A, see Figure 58.

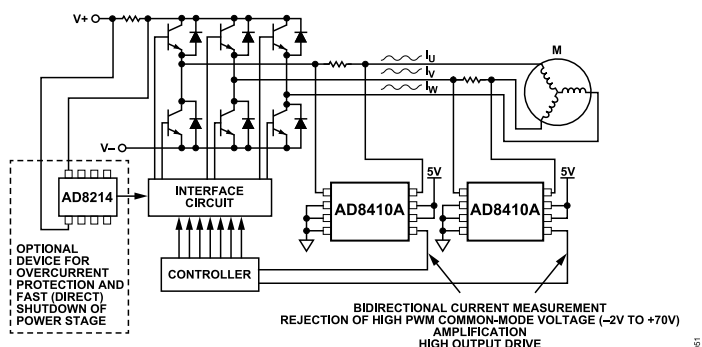

Figure 58. 3-Phase Motor Control

## H-Bridge Motor Control

Another typical application for the AD8410A is to form part of the control loop in H-bridge motor control. In this case, place the shunt resistor in the middle of the H-bridge to accurately measure current in both directions by using the shunt available at the motor (see Figure 59). Using an amplifier and shunt in this location is a more accurate solution than a ground-referenced op amp because ground is not typically a stable reference voltage in this type of application. The instability of the ground reference causes inaccuracies in the measurements that can be made with a simple ground referenced op amp. The AD8410A measures current in both directions as the H-bridge switches and the motor changes direction. The output of the AD8410A is configured in an external referenced bidirectional mode (see the Bidirectional Operation section).

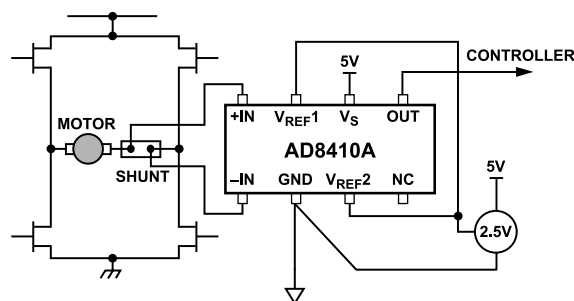

Figure 59. H-Bridge Motor Control

APPLICATIONS INFORMATION

SOLENOID CONTROL

High-Side Current Sense with a Low-Side Switch

In the case of a high-side current sense with a low-side switch, the PWM control switch is ground referenced. Connect an inductive load (solenoid) to a power supply and place a resistive shunt between the switch and the load (see Figure 60). An advantage of placing the shunt on the high side is that the entire current, including the recirculation current, is measurable because the shunt remains in the loop when the switch is off. In addition, diagnostics are enhanced because shorts to ground are detected with the shunt on the high side.

In this circuit configuration, when the switch is closed, the common-mode voltage decreases to near the negative rail. When the switch is open, the voltage reversal across the inductive load causes the common-mode voltage to be held one diode drop above the battery by the clamp diode.

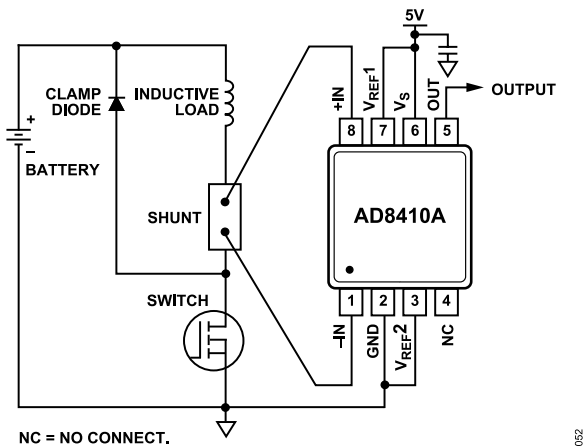

Figure 60. Low-Side Switch

High-Side Current Sense with a High-Side Switch

The high-side current sense with a high-side switch configuration minimizes the possibility of unexpected solenoid activation and excessive corrosion due to constant battery draw (see Figure 61). In this case, both the switch and the shunt are on the high side. When the switch is off, the battery is removed from the load, which prevents damage from potential shorts to ground while still allowing the recirculating current to be measured and to provide diagnostics. Removing the power supply from the load for the majority of the time that the switch is open minimizes the corrosive effects that can be caused by the differential voltage between the load and ground.

When using a high-side switch, the battery voltage is connected to the load when the switch is closed, causing the common-mode voltage to increase to the same value as the battery voltage. In this case, when the switch is open, the voltage reversal across the

inductive load causes the common-mode voltage to be held one diode drop below ground by the clamp diode.

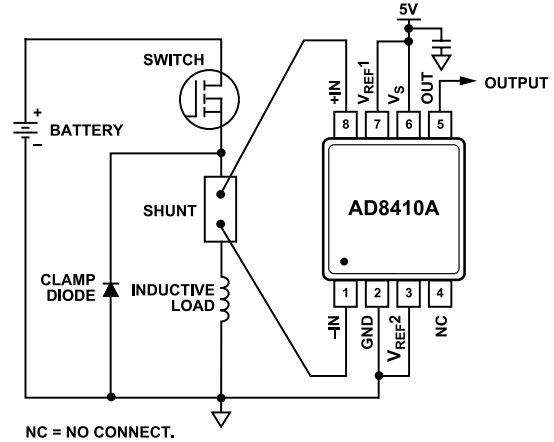

Figure 61. High-Side Switch

High Rail Current Sensing

In the high rail current sensing configuration, the shunt resistor is referenced to the battery. High voltage is present at the inputs of the current-sense amplifier. When the shunt is battery referenced, the AD8410A produces a linear ground-referenced analog output. Additionally, the AD8214 provides an overcurrent detection signal in <100 ns (see Figure 62). This feature is useful in high current systems where fast shutdown in overcurrent conditions is essential.

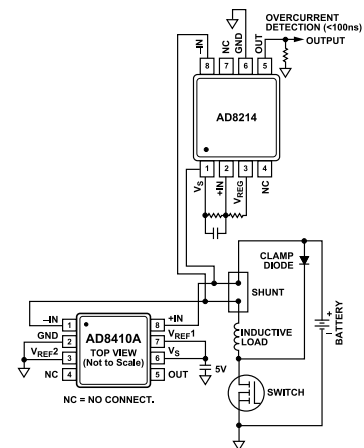

Figure 62. High Rail Current Sensing

INPUT FILTER

In typical applications, such as motor control and solenoid current sensing, filtering at the input of the AD8410A can be beneficial in reducing differential noise, as well as transients and current ripples flowing through the input shunt resistor. Also, it is recommended to filter at the input of the AD8410A to further reduce the electromagnetic interference (EMI). The EMI specifications vary depending on the application. Filter at the input if the output cannot be filtered because filtering at the output changes the low output impedance

## APPLICATIONS INFORMATION

seen by the components attached to the output of the AD8410A. The +IN and -IN pins of the AD8410A have balanced input-bias currents. The input series resistors, R1 and R2 in Figure 63, must be the same measured value not to add large offset voltage on the output of the device as a result of R1 and R2. It is recommended to keep R1 and R2 at or below 100 Ω. In Figure 63, C1 and C3 must be the same value.

For example, at 48 V common-mode, when using a 10 Ω resistor for R1 and R2, the estimated maximum error that is seen on the input of the AD8410A ( $V_{ErrorRTI}$ ) due to the R1 and R2 resistors in the input filter is:

$$V_{ErrorRTI} = 10 \Omega \times 2.7 \mu A = 27 \mu V \quad (3)$$

Where 2.7 μA is the maximum input offset current at 48 V input common mode, as listed in Table 1.

The EMI filter has two different bandwidths, common-mode and differential. The differential bandwidth defines the frequency response of the filter with a differential input signal applied between the two inputs of the amplifier, +IN and -IN.

The -3 dB differential bandwidth for the filter is:

$$BW_{DIFF} = \frac{1}{2\pi \times R1 \times ((2 \times C2) + C1)} \quad (4)$$

The common-mode bandwidth defines what a common-mode RF signal sees between GND and the +IN and -IN of the amplifier tied together.

The -3 dB common-mode bandwidth for the filter is:

$$BW_{CM} = \frac{1}{2\pi \times R1 \times C1} \quad (5)$$

Keep the resistor values to a 1% tolerance and the filter capacitors to a 5% tolerance to assist with reducing AC common-mode rejection (CMR) errors. Choose C2 to be at least 10× larger than C1 or C3 to reduce AC CMR errors, which are caused by component mismatching.

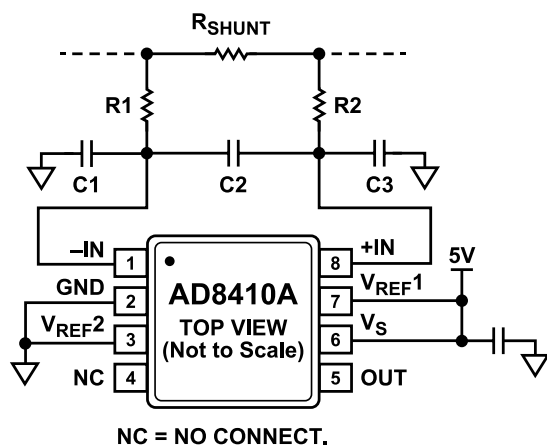

Figure 63. Input Filter

## OVERCURRENT DETECTION

In several current sensing applications, it is required to quickly detect when the current exceeds a certain threshold in the presence of a fault condition for safety concerns. As mentioned in the High Rail Current Sensing section, the AD8214 can be used for overcurrent detection in high current systems where fast shutdown in overcurrent conditions is essential.

Another common practice for overcurrent detection in current-sense applications is to use a comparator on the output of the current-sense amplifier. Figure 64 and Figure 65 show typical configurations for monitoring current and using a comparator for overcurrent detection in unidirectional current and bidirectional currents, respectively.

Choose the values of R1 and R2 in Figure 64 and Figure 65 to set the threshold voltage at which the overcurrent detection trips. For example, for the bidirectional overcurrent detection configuration shown in Figure 65, if the shunt resistance ( $R_{SHUNT}$ ) is 25 mΩ, and it is required to trip the overcurrent detection at ±3 A, use Equation 6, Equation 7, and Equation 8 to find the R1 value after choosing an arbitrary value for R2. Choose, R2 = 4800 Ω, and  $V_S = 5$  V.

Threshold voltage ( $V_{THR}$ ) is the voltage that the output of the AD8410A must reach to trip the overcurrent detection. If it is required that the overcurrent detection trips at 3 A, then:

$$V_{THR} = 3 A \times R_{SHUNT} \times 20 V/V + 2.5 V \quad (6)$$

The 2.5 V is added because the references are set up in split supply mode, then:

$$V_{THR} = 3 A \times 25 m\Omega \times 20 V/V + 2.5 V = 4 V \quad (7)$$

After  $V_{THR}$  is known, use the following Equation 8 to find R1:

$$R1 = \frac{R2(V_S - V_{THR})}{V_{THR}} = \frac{4800 \Omega \times (5 V - 4 V)}{4 V} = 1200 \Omega \quad (8)$$

For the second ADCMP601, keep the same values for R1 and R2. Attach the  $V_N$  pin to the output of the AD8410A, attach R2 to the 5 V supply, attach R1 to ground, and attach the  $V_P$  pin to the connection between R2 and R1 to allow negative overcurrent detection (as shown in Figure 65).

Therefore, when the output of the AD8410A reaches as shown in Equation 9, then the output of the ADCMP601 used for negative overcurrent detection trips high.

$$(2.5 V - 3 A \times 25 m\Omega \times 20 V/V) = 1 V \quad (9)$$

APPLICATIONS INFORMATION

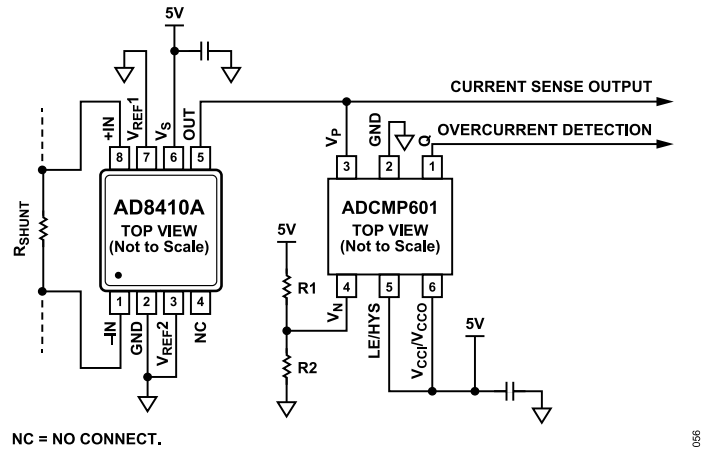

Figure 64. Unidirectional Overcurrent Detection

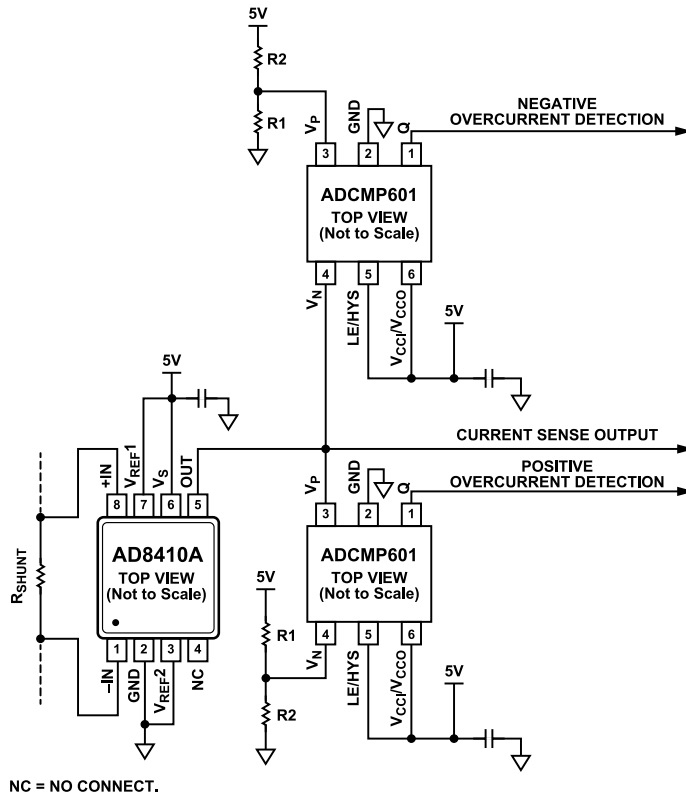
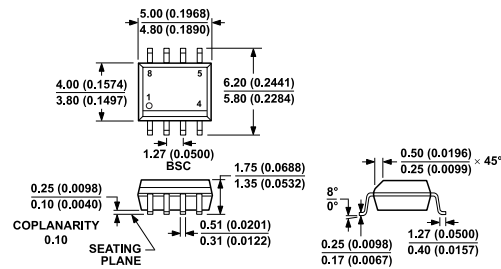

Figure 65. Bidirectional Overcurrent Detection

OUTLINE DIMENSIONS



COMPLIANT TO JEDEC STANDARDS MS-012-AA  
 CONTROLLING DIMENSIONS ARE IN MILLIMETERS; INCH DIMENSIONS (IN PARENTHESES) ARE ROUNDED-OFF MILLIMETER EQUIVALENTS FOR REFERENCE ONLY AND ARE NOT APPROPRIATE FOR USE IN DESIGN.

Figure 66. 8-Lead Standard Small Outline Package [SOIC\_N] Narrow Body (R-8)  
 Dimensions Shown in millimeters and (inches)

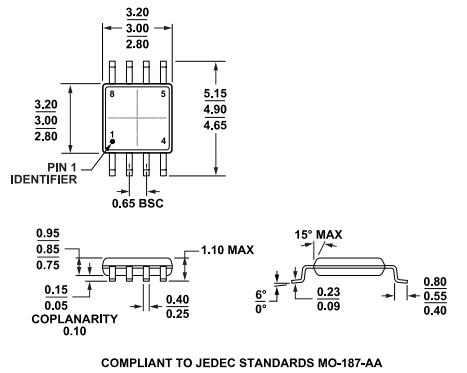

COMPLIANT TO JEDEC STANDARDS MO-187-AA

Figure 67. 8-Lead Mini Small Outline Package [MSOP] Narrow Body (RM-8)  
 Dimensions Shown in millimeters and (inches)

Updated: January 21, 2023

ORDERING GUIDE

Model <sup>1,2</sup>	Temperature Range	Package Description	Packing Quantity	Package Option	Marking Code
AD8410AWBRZ	-40°C to +125°C	8-Lead SOIC_N		R-8	
AD8410AWBRZ-RL	-40°C to +125°C	8-Lead SOIC_N	Reel, 2500	R-8	
AD8410AWBRMZ	-40°C to +125°C	8-Lead MSOP		RM-8	A52
AD8410AWBRMZ-RL	-40°C to +125°C	8-Lead MSOP	Reel, 3000	RM-8	A52

<sup>1</sup> Z = RoHS Compliant Part.

<sup>2</sup> W = Qualified for Automotive Applications.

EVALUATION BOARDS

Model <sup>1</sup>	Description
AD8410AR-EVALZ	Evaluation Board for 8-Lead Standard Small Outline Package [SOIC_N]
AD8410ARM-EVALZ	Evaluation Board for 8-Lead Mini Small Outline Package [MSOP]

<sup>1</sup> Z = RoHS Compliant Part.

AUTOMOTIVE PRODUCTS

The AD8410A models are available with controlled manufacturing to support the quality and reliability requirements of automotive applications. Note that these automotive models may have specifications that differ from the commercial models; therefore, designers should review the