



# Audio Processor for Advanced TV

## ADAV4601

### FEATURES

- Fully programmable 28-bit audio processor for enhanced ATV sound—default audio processing flow loaded on reset
- Implements Analog Devices, Inc. and third-party branded audio algorithms
- Adjustable digital delay line for audio/video synchronization for up to 200 ms stereo delay
- High performance 24-bit ADC and DAC
  - 94 dB DNR performance on DAC channels
  - 95 dB DNR performance on ADC channels
- Headphone output with integrated amplifiers
- High performance pulse-width modulation (PWM) digital outputs
- Multichannel digital baseband I/O
  - 4 stereo synchronous digital I<sup>2</sup>S input channels
  - One 6-channel sample rate converter (SRC) and one stereo SRC supporting input sample rates from 5 kHz to 50 kHz
  - One stereo synchronous digital I<sup>2</sup>S output
  - S/PDIF output with S/PDIF input mux capability
- Fast I<sup>2</sup>C control
- Operates from 3.3 V (analog), 1.8 V (digital core), and 3.3 V (digital interface)
- Available in 80-lead LQFP

### APPLICATIONS

- General-purpose consumer audio post processing
  - Home audio
  - DVD recorders
  - Home theater in a box systems and DVD receivers
- Audio processing subsystems for DTV-ready TVs
- Analog broadcast capability for iDTVs

### GENERAL DESCRIPTION

The ADAV4601 is an enhanced audio processor targeting advanced TV applications with full support for digital and analog baseband audio.

The audio processor, by default, loads a dedicated TV audio flow that incorporates full matrix switching (any input to any output), automatic volume control that compensates for volume changes during advertisements or when switching channels, dynamic bass, a multiband equalizer, and up to 200 ms of stereo delay memory for audio-video synchronization.

Alternatively, Analog Devices offers an award-winning graphical programming tool (SigmaStudio™) that allows custom flows to be quickly developed and evaluated. This allows the creation of customer-specific audio flows, including the use of ADI library of third-party algorithms.

The analog I/O integrates Analog Devices proprietary continuous-time, multibit  $\Sigma$ - $\Delta$  architecture to bring a higher level of performance to ATV systems, required by third-party algorithm providers to meet system branding certification. The analog input is provided by 95 dB dynamic range (DNR) ADCs, and analog output is provided by 94 dB DNR DACs.

The main speaker outputs can be supplied as a digitally modulated PWM stream to support digital amplifiers.

The ADAV4601 includes multichannel digital inputs and outputs. In addition, digital input channels can be routed through integrated sample rate converters (SRC), which are capable of supporting any arbitrary sample rate from 5 kHz to 50 kHz.



### Rev. B

Information furnished by Analog Devices is believed to be accurate and reliable. However, no responsibility is assumed by Analog Devices for its use, nor for any infringements of patents or other rights of third parties that may result from its use. Specifications subject to change without notice. No license is granted by implication or otherwise under any patent or patent rights of Analog Devices. Trademarks and registered trademarks are the property of their respective owners.

One Technology Way, P.O. Box 9106, Norwood, MA 02062-9106, U.S.A.  
Tel: 781.329.4700 [www.analog.com](http://www.analog.com)  
Fax: 781.461.3113 ©2008–2009 Analog Devices, Inc. All rights reserved.

**TABLE OF CONTENTS**

Features .....	1	DAC Voltage Outputs .....	22
Applications .....	1	PWM Outputs .....	22
General Description .....	1	Headphone Output .....	22
Revision History .....	3	I <sup>2</sup> S Digital Audio Outputs .....	23
Functional Block Diagram .....	4	S/PDIF Input/Output .....	23
Specifications .....	5	Hardware Mute Control .....	23
Performance Parameters .....	5	Audio Processor .....	23
Timing Specifications .....	7	Graphical Programming Environment .....	23
Timing Diagrams .....	8	SigmaStudio Pin Assignment .....	24
Absolute Maximum Ratings .....	9	Application Layer .....	24
Thermal Resistance .....	9	Loading a Custom Audio Processing Flow .....	24
Thermal Conditions .....	9	Numeric Formats .....	24
ESD Caution .....	9	ROMs and Registers .....	25
Pin Configuration and Function Descriptions .....	10	Safe Loading to Parameter RAM and Target/Slew RAM .....	25
Typical Performance Characteristics .....	12	Read/Write Data Formats .....	25
Terminology .....	14	Target/Slew RAM .....	26
Pin Functions .....	15	Layout Recommendations .....	28
Detailed Pin Descriptions .....	15	Typical Application Diagram .....	29
Functional Descriptions .....	17	Audio Flow Control Registers .....	31
Power-Up Sequence .....	17	Detailed Register Descriptions .....	31
Master Clock Oscillator .....	17	Main Control Registers .....	48
I <sup>2</sup> C Interface .....	17	Detailed Register Descriptions .....	48
I <sup>2</sup> C Read and Write Operations .....	19	Outline Dimensions .....	58
ADC Inputs .....	19	Ordering Guide .....	58
I <sup>2</sup> S Digital Audio Inputs .....	20		

**REVISION HISTORY**

**9/09—Rev. A to Rev. B**

Changes to Table 11 .....24  
 Changes to Table 15 .....31  
 Changes to Table 16 .....32  
 Changes to Table 40 .....45  
 Changes to Table 50 .....51  
 Changes to Table 51 .....53  
 Changes to Table 54 .....54

**4/09—Rev. 0 to Rev. A**

Added Advantiv Logo ..... 1  
 Changes to General Description Section ..... 1  
 Changes to Figure 1 ..... 3  
 Changes to Table 2 ..... 6  
 Changes to FILTA and FILTD Section, AVDD Section, and VDD Section ..... 15  
 Added Power-Up Sequence Section and Figure 22; Renumbered Sequentially ..... 16  
 Changes to Master Clock Oscillator Section ..... 16  
 Added Table 6, Table 7, Table 8, Table 9, and Figure 23; Renumbered Sequentially ..... 17  
 Added Figure 24 ..... 18  
 Changes to ADC Inputs Section and Figure 25 ..... 18

Added Figure 31 ..... 21  
 Changes to DAC Voltage Outputs Section, Figure 30, PWM Outputs Section, Headphone Output Section, and Figure 33... 21  
 Added Figure 36 ..... 22  
 Changes to Hardware Mute Control Section ..... 22  
 Added SigmaStudio Pin Assignment Section, Table 10, Table 11, and Numeric Formats Section ..... 23  
 Changes to Application Layer Section ..... 23  
 Added Figure 38, ROMs and Registers Section, Safe Loading to Parameter RAM and Target/Slew RAM Section, and Read/Write Data Formats Section ..... 24  
 Added Target/Slew RAM Section, Table 12, Table 13, and Table 14 ..... 25  
 Added Figure 39, Figure 40, Figure 41, Figure 42, and Figure 43 ..... 26  
 Added Figure 44, Figure 45, Figure 46, and Layout Recommendations Section ..... 27  
 Changes to Figure 47 ..... 28  
 Added Figure 48 ..... 29  
 Added Table 15 to Table 61 ..... 30

**3/08—Revision 0: Initial Version**

## FUNCTIONAL BLOCK DIAGRAM

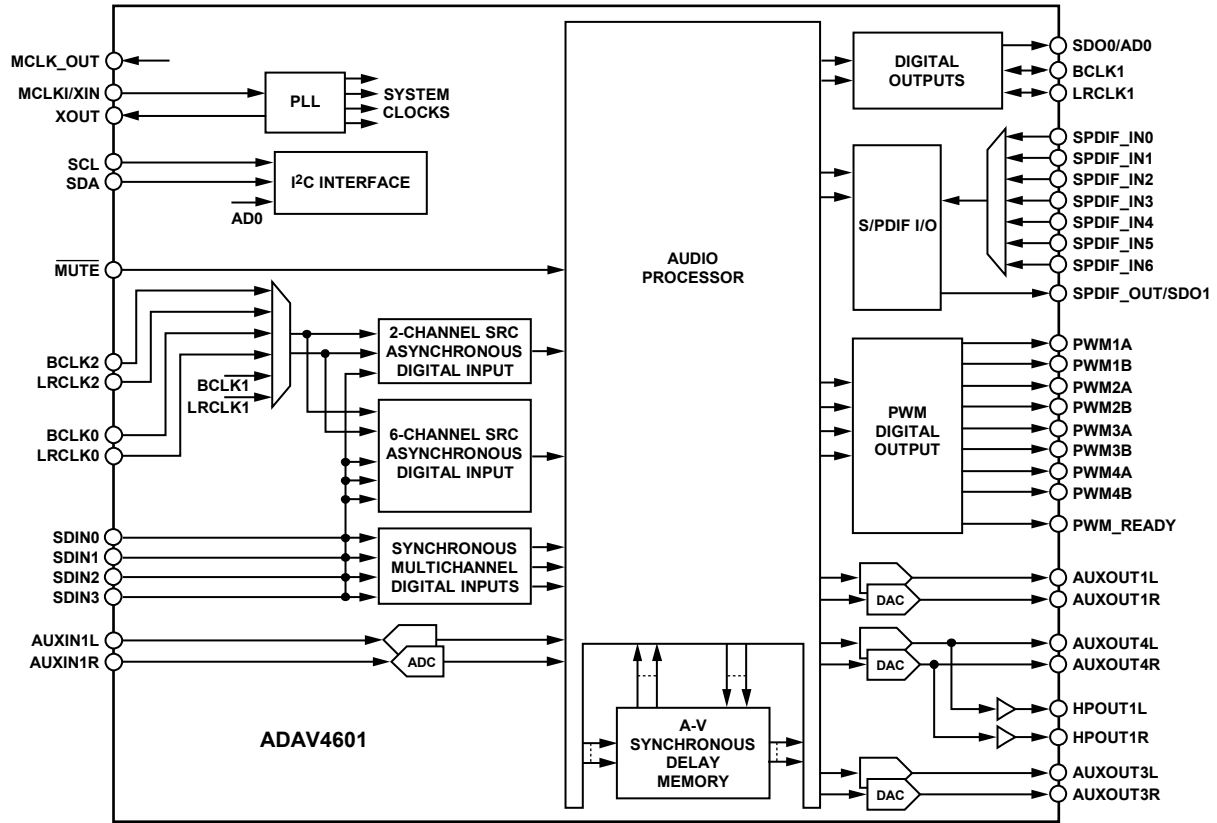

Figure 1. ADAV4601 with PWM-Based Speaker Outputs

07070-001

## SPECIFICATIONS

AVDD = 3.3 V, DVDD = 1.8 V, ODVDD = 3.3 V, operating temperature =  $-40^{\circ}\text{C}$  to  $+85^{\circ}\text{C}$ , master clock 24.576 MHz, measurement bandwidth = 20 Hz to 20 kHz, ADC input signal = DAC output signal = 1 kHz, unless otherwise noted.

### PERFORMANCE PARAMETERS

Table 1.

Parameter	Min	Typ	Max	Unit	Test Conditions/Comments
REFERENCE SECTION					
Absolute Voltage $V_{\text{REF}}$		1.53		V	
$V_{\text{REF}}$ Temperature Coefficient		100		ppm/ $^{\circ}\text{C}$	
ADC SECTION					
Number of Channels		2			One stereo channel
Full-Scale Input Level		100		$\mu\text{A rms}$	
Resolution		24		Bits	
Dynamic Range (Stereo Channel)					
A-Weighted		95		dB	$-60$ dBFS with respect to full-scale analog input
Total Harmonic Distortion + Noise (Stereo Channel)		$-90$		dB	$-3$ dBFS with respect to full-scale analog input
Gain Mismatch		0.2		dB	Left- and right-channel gain mismatch
Crosstalk (Left-to-Right, Right-to-Left)		$-110$		dB	
Gain Error		$-1$		dB	Input signal is 100 $\mu\text{A rms}$
Current Setting Resistor ( $R_{\text{ISET}}$ )		20		k $\Omega$	External resistor to set current input range of ADC for nominal 2.0 V rms input signal
Power Supply Rejection		$-87$		dB	1 kHz, 300 mV p-p signal at AVDD
ADC DIGITAL DECIMATOR FILTER CHARACTERISTICS					
Pass Band		22.5		kHz	At 48 kHz, guaranteed by design
Pass-Band Ripple		$\pm 0.0002$		dB	
Stop Band		26.5		kHz	
Stop-Band Attenuation		100		dB	
Group Delay		1040		$\mu\text{s}$	
PWM SECTION					
Frequency		384		kHz	Guaranteed by design
Modulation Index		0.976			Guaranteed by design
Dynamic Range					
A-Weighted		98		dB	$-60$ dBFS with respect to full-scale code input
Total Harmonic Distortion + Noise		$-80$		dB	$-3$ dBFS with respect to full-scale code input
DAC SECTION					
Number of Auxiliary Output Channels		6			Three stereo channels
Resolution		24		Bits	
Full-Scale Analog Output		1		V rms	
Dynamic Range					
A-Weighted		94		dB	$-60$ dBFS with respect to full-scale code input
Total Harmonic Distortion + Noise		$-86$		dB	$-3$ dBFS with respect to full-scale code input
Crosstalk (Left-to-Right, Right-to-Left)		$-102$		dB	
Interchannel Gain Mismatch		0.1		dB	Left- and right-channel gain mismatch
Gain Error		0.525		dB	1 V rms output
DC Bias		1.53		V	
Power Supply Rejection		$-90$		dB	1 kHz, 300 mV p-p signal at AVDD
Output Impedance		235		$\Omega$	

# ADAV4601

Parameter	Min	Typ	Max	Unit	Test Conditions/Comments
<b>DAC DIGITAL INTERPOLATION FILTER CHARACTERISTICS</b>					
Pass Band		21.769		kHz	At 48 kHz, guaranteed by design
Pass-Band Ripple		±0.01		dB	
Transition Band		23.95		kHz	
Stop Band		26.122		kHz	
Stop-Band Attenuation		75		dB	
Group Delay		580		µs	
<b>HEADPHONE AMPLIFIER</b>					
Number of Channels		2			Measured at headphone output with 32 Ω load One stereo channel 1 V rms output –60 dBFS with respect to full-scale code input –3 dBFS with respect to full-scale code input 1 kHz, 300 mV p-p signal at AVDD
Full-Scale Output Power		31		mW rms	
Dynamic Range					
A-Weighted		93		dB	
Total Harmonic Distortion + Noise		–83		dB	
Interchannel Gain Mismatch		0.1		dB	
DC Bias		1.53		V	
Power Supply Rejection		–85		dB	
<b>SRC</b>					
Number of Channels		8			Two channels (SRC1), six channels (SRC2) –60 dBFS input (worst-case input $f_s = 50$ kHz) –3 dBFS input (worst-case input $f_s = 50$ kHz)
Dynamic Range					
A-Weighted		115		dB	
Total Harmonic Distortion + Noise		–113		dB	
Sample Rate	5		50	kHz	
<b>SRC DIGITAL INTERPOLATION FILTER CHARACTERISTICS</b>					
Pass Band		21.678		kHz	At 48 kHz, guaranteed by design
Pass-Band Ripple		0.005		dB	
Stop Band		26.232		kHz	
Stop-Band Attenuation		110		dB	
Group Delay		876		µs	
<b>DIGITAL INPUT/OUTPUT</b>					
Input Voltage High ( $V_{IH}$ )	2.0		ODVDD	V	$V_{IH} = ODVDD$ , equivalent to a 90 kΩ pull-up resistor  $V_{IH} = ODVDD$ , equivalent to a 266 kΩ pull-up resistor $V_{IL} = 0$ V, equivalent to a 90 kΩ pull-down resistor $I_{OH} = 0.4$ mA $I_{OL} = -2$ mA $I_{OH} = 0.4$ mA $I_{OL} = -3.2$ mA
Input Voltage Low ( $V_{IL}$ )			0.8	V	
Input Leakage		40		µA	
$I_{IH}$ (SDIN0, SDIN1, SDIN2, SDIN3, LRCLK0, LRCLK1, LRCLK2, BCLK0, BCLK1, BCLK2, SPDIF_OUT, SPDIF_IN)		13.5		µA	
$I_{IH}$ (RESET)		–40		µA	
$I_{IL}$ (SDOO, SCL, SDA)				µA	
Output Voltage High ( $V_{OH}$ )	2.4			V	
Output Voltage Low ( $V_{OL}$ )			0.4	V	
Output Voltage High ( $V_{OH}$ ) (MCLK_OUT)	1.4			V	
Output Voltage Low ( $V_{OL}$ ) (MCLK_OUT)			0.4	V	
Input Capacitance		10		pF	
<b>SUPPLIES</b>					
Analog Supplies (AVDD)	3.0	3.3	3.6	V	MCLK = 24 MHz, ADCs and DACs active, headphone outputs active and driving a 16 Ω load
Digital Supplies (DVDD)	1.65	1.8	2.0	V	
Interface Supply (ODVDD)	3.0	3.3	3.6	V	
Supply Currents					
Analog Current		115		mA	
Digital Current		160		mA	
Interface Current		2		mA	

Parameter	Min	Typ	Max	Unit	Test Conditions/Comments
Power Dissipation		0.674		W	ADC, DAC, and headphone outputs floating, RESET low, MCLK = 24 MHz
Standby Currents					
Analog Current		7		mA	
Digital Current		3		mA	
Interface Current		1.6		mA	
<b>TEMPERATURE RANGE</b>					
Operating Temperature	-40		+85	°C	
Storage Temperature	-65		+150	°C	

## TIMING SPECIFICATIONS

Table 2.

Parameter	Description	Min	Max	Unit	Comments
<b>MASTER CLOCK AND RESET</b>					
f <sub>MCLKI</sub>	MCLKI frequency	3.072	24.576	MHz	
t <sub>MP</sub>	MCLKI period	40	325	ns	
t <sub>MCH</sub>	MCLKI high	10		ns	
t <sub>MCL</sub>	MCLKI low	10		ns	
t <sub>RESET</sub>	RESET low	200		ns	
<b>MASTER CLOCK OUTPUT</b>					
t <sub>CK</sub>	MCLK_OUT period	8	162	ns	
t <sub>JIT</sub>	Period jitter		800	ps	
t <sub>CH</sub>	MCLK_OUT high	45	55	%	
t <sub>CL</sub>	MCLK_OUT low	45	55	%	
<b>I<sup>2</sup>C PORT</b>					
f <sub>SCL</sub>	SCL clock frequency		400	kHz	
t <sub>SCLH</sub>	SCL high	600		ns	
t <sub>SCLL</sub>	SCL low	1.3		µs	
<b>Start Condition</b>					
t <sub>SCS</sub>	Setup time	600		ns	Relevant for repeated start condition After this period, the first clock is generated
t <sub>SCH</sub>	Hold time	600		ns	
t <sub>DS</sub>	Data setup time	100		ns	
t <sub>SCR</sub>	SCL rise time		300	ns	
t <sub>SCF</sub>	SCL fall time		300	ns	
t <sub>SDR</sub>	SDA rise time		300	ns	
t <sub>SDF</sub>	SDA fall time		300	ns	
<b>Stop Condition</b>					
t <sub>SCS</sub>	Setup time	0		ns	
<b>SERIAL PORTS</b>					
<b>Slave Mode</b>					
t <sub>SBH</sub>	BCLK high	40		ns	
t <sub>SBL</sub>	BCLK low	40		ns	
f <sub>SBF</sub>	BCLK frequency	64 × f <sub>S</sub>			
t <sub>SLS</sub>	LRCLK setup	10		ns	To BCLK rising edge
t <sub>SLH</sub>	LRCLK hold	10		ns	From BCLK rising edge
t <sub>SDS</sub>	SDIN setup	10		ns	To BCLK rising edge
t <sub>SDH</sub>	SDIN hold	10		ns	From BCLK rising edge
t <sub>SDD</sub>	SDO delay		50	ns	From BCLK falling edge
<b>Master Mode</b>					
t <sub>MLD</sub>	LRCLK delay		25	ns	From BCLK falling edge
t <sub>MDD</sub>	SDO delay		15	ns	From BCLK falling edge
t <sub>MDS</sub>	SDIN setup	10		ns	From BCLK rising edge
t <sub>MDH</sub>	SDIN hold	10		ns	From BCLK rising edge

## TIMING DIAGRAMS

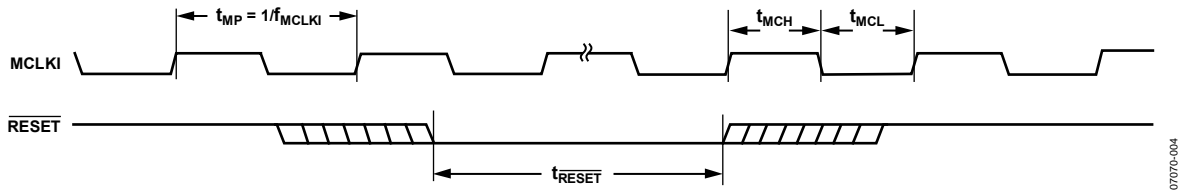

Figure 2. Master Clock and Reset Timing

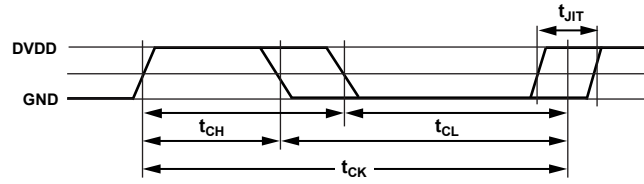

Figure 3. Master Clock Output Timing

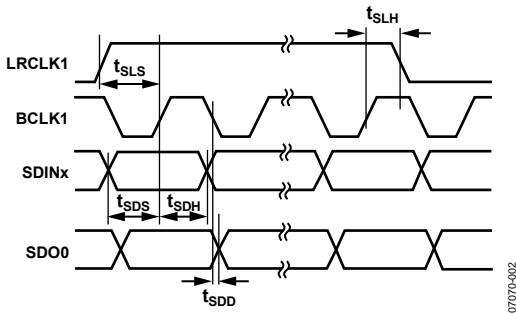

Figure 4. Serial Port Slave Mode Timing

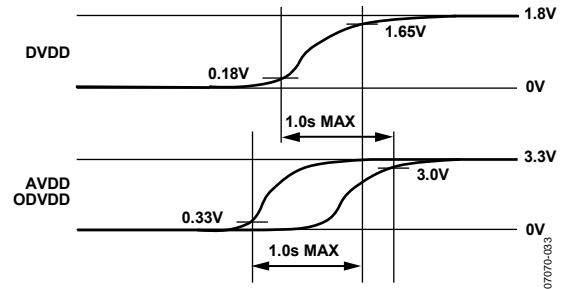

Figure 7. Power-Up Sequence Timing

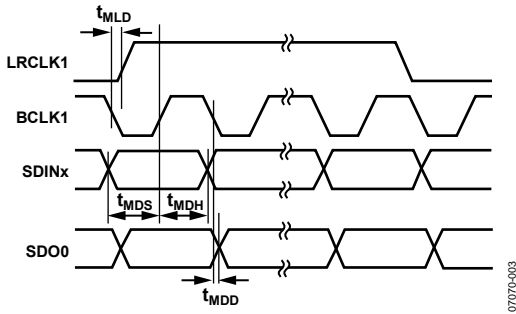

Figure 5. Serial Port Master Mode Timing

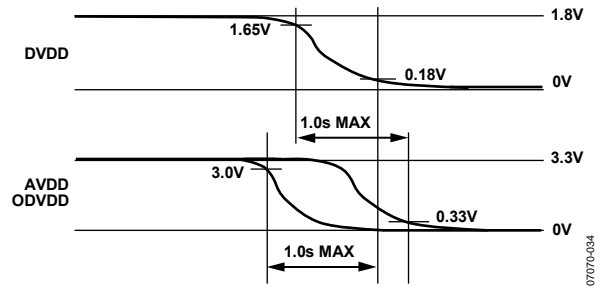

Figure 8. Power-Down Sequence Timing

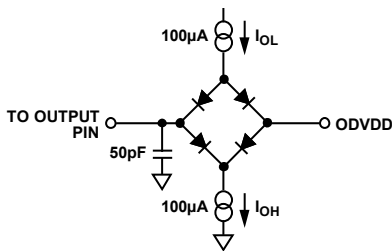

Figure 6. Load Circuit for Digital Output Timing Specifications



## ABSOLUTE MAXIMUM RATINGS

Table 3.

Parameter	Rating
DVDD to DGND	0 V to 2.2 V
ODVDD to DGND	0 V to 4 V
AVDD to AGND	0 V to 4 V
AGND to DGND	-0.3 V to +0.3 V
Digital Inputs	DGND - 0.3 V to ODVDD + 0.3 V
Analog Inputs	AGND - 0.3 V to AVDD + 0.3 V
Reference Voltage	Indefinite short circuit to ground
Soldering (10 sec)	300°C

Stresses above those listed under Absolute Maximum Ratings may cause permanent damage to the device. This is a stress rating only; functional operation of the device at these or any other conditions above those indicated in the operational section of this specification is not implied. Exposure to absolute maximum rating conditions for extended periods may affect device reliability.

## THERMAL RESISTANCE

$\theta_{JA}$  is specified for the worst-case conditions, that is, a device soldered in a circuit board for surface-mount packages.

Thermal resistance is based on JEDEC 2S2P PCB.

Table 4.

Package Type	$\theta_{JA}$	$\theta_{JC}$	Unit
80-Lead LQFP	38.1	7.6	°C/W

## THERMAL CONDITIONS

To ensure correct operation of the device, the case temperature ( $T_{CASE}$ ) must be kept below 121°C to keep the junction temperature ( $T_j$ ) below the maximum allowed, 125°C.

## ESD CAUTION



**ESD (electrostatic discharge) sensitive device.** Charged devices and circuit boards can discharge without detection. Although this product features patented or proprietary protection circuitry, damage may occur on devices subjected to high energy ESD. Therefore, proper ESD precautions should be taken to avoid performance degradation or loss of functionality.

## PIN CONFIGURATION AND FUNCTION DESCRIPTIONS

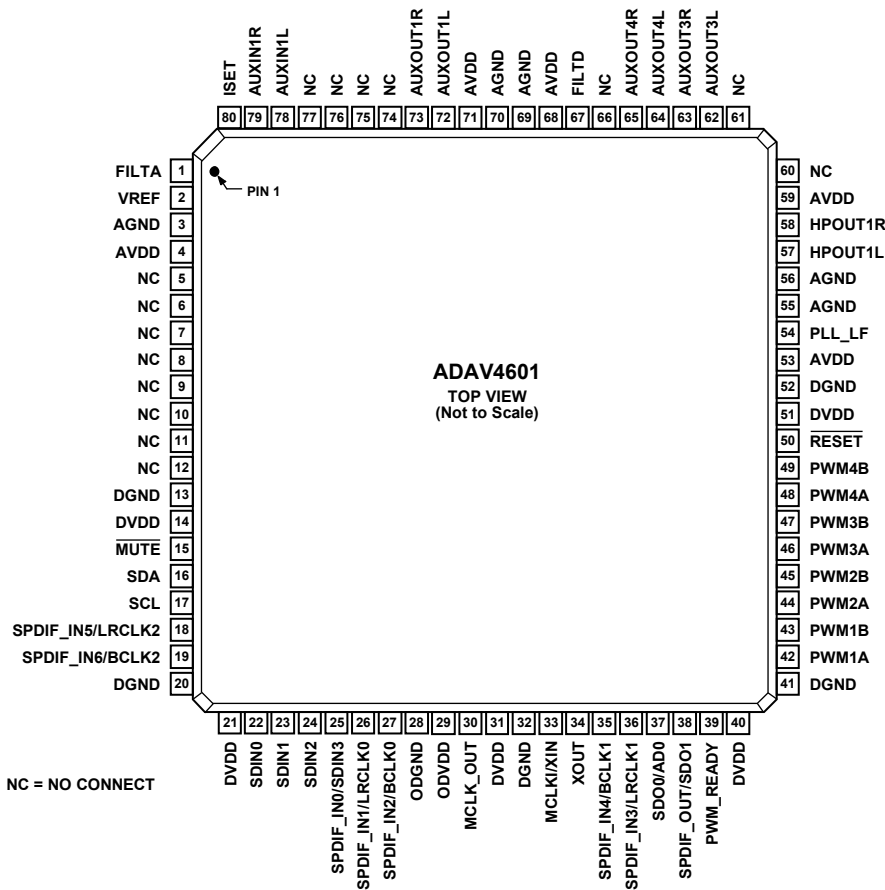

Figure 9. Pin Configuration

Table 5. Pin Function Descriptions

Pin No.	Mnemonic	Description
1	FILTA	ADC Filter Capacitor.
2	VREF	Reference Capacitor.
3	AGND	ADC Ground.
4	AVDD	ADC Supply (3.3 V).
5 to 12	NC	No Connection to This Pin Allowed.
13	DGND	Digital Ground.
14	DVDD	Digital Supply (1.8 V).
15	MUTE	Active-Low Mute Request Input Signal.
16	SDA	I <sup>2</sup> C Data.
17	SCL	I <sup>2</sup> C Clock.
18	SPDIF_IN5/LRCLK2	External Input to S/PDIF Mux/Left/Right Clock for SRC2 (Default).
19	SPDIF_IN6/BCLK2	External Input to S/PDIF Mux/Bit Clock for SRC2 (Default).
20	DGND	Digital Ground.
21	DVDD	Digital Supply (1.8 V).
22	SDIN0	Serial Data Input 0/SRC Data Input.
23	SDIN1	Serial Data Input 1/SRC Data Input.
24	SDIN2	Serial Data Input 2/SRC Data Input.

Pin No.	Mnemonic	Description
25	SPDIF_IN0/SDIN3	External Input to S/PDIF Mux/SRC Data Input/Serial Data Input 3 (Default).
26	SPDIF_IN1/LRCLK0	External Input to S/PDIF Mux/Left/Right Clock for SRC1 (Default).
27	SPDIF_IN2/BCLK0	External Input to S/PDIF Mux/Bit Clock for SRC1 (Default).
28	ODGND	Digital Ground.
29	ODVDD	Digital Interface Supply (3.3 V).
30	MCLK_OUT	Master Clock Output.
31	DVDD	Digital Supply (1.8 V).
32	DGND	Digital Ground.
33	MCLKI/XIN	Master Clock/Crystal Input.
34	XOUT	Crystal Output.
35	SPDIF_IN4/BCLK1	External Input to S/PDIF Mux/Bit Clock for Serial Data I/O (Default).
36	SPDIF_IN3/LRCLK1	External Input to S/PDIF Mux/Left/Right Clock for Serial Data I/O (Default).
37	SDO0/AD0	Serial Data Output. This pin acts as the I <sup>2</sup> C address select on reset. It has an internal pull-down resistor.
38	SPDIF_OUT/SDO1	Output of S/PDIF Mux/Serial Data Output.
39	PWM_READY	PWM Ready Flag.
40	DVDD	Digital Supply (1.8 V).
41	DGND	Digital Ground.
42	PWM1A	Pulse-Width Modulated Output 1A.
43	PWM1B	Pulse-Width Modulated Output 1B.
44	PWM2A	Pulse-Width Modulated Output 2A.
45	PWM2B	Pulse-Width Modulated Output 2B.
46	PWM3A	Pulse-Width Modulated Output 3A.
47	PWM3B	Pulse-Width Modulated Output 3B.
48	PWM4A	Pulse-Width Modulated Output 4A.
49	PWM4B	Pulse-Width Modulated Output 4B.
50	RESET	Reset Analog and Digital Cores.
51	DVDD	Digital Supply (1.8 V).
52	DGND	Digital Ground.
53	AVDD	PLL Supply (3.3 V).
54	PLL_LF	PLL Loop Filter.
55	AGND	PLL Ground.
56	AGND	Headphone Driver Ground.
57	HPOUT1L	Left Headphone Output.
58	HPOUT1R	Right Headphone Output.
59	AVDD	Headphone Driver Supply (3.3 V).
60, 61	NC	No Connection to This Pin Allowed.
62	AUXOUT3L	Left Auxiliary Output 3.
63	AUXOUT3R	Right Auxiliary Output 3.
64	AUXOUT4L	Left Auxiliary Output 4.
65	AUXOUT4R	Right Auxiliary Output 4.
66	NC	No Connection to This Pin Allowed.
67	FILTD	DAC Filter Capacitor.
68	AVDD	DAC Supply (3.3 V).
69	AGND	DAC Ground.
70	AGND	DAC Ground.
71	AVDD	DAC Supply (3.3 V).
72	AUXOUT1L	Left Auxiliary Output 1.
73	AUXOUT1R	Right Auxiliary Output 1.
74 to 77	NC	No Connection to This Pin Allowed.
78	AUXIN1L	Left Auxiliary Input 1.
79	AUXIN1R	Right Auxiliary Input 1.
80	ISET	ADC Current Setting.

TYPICAL PERFORMANCE CHARACTERISTICS

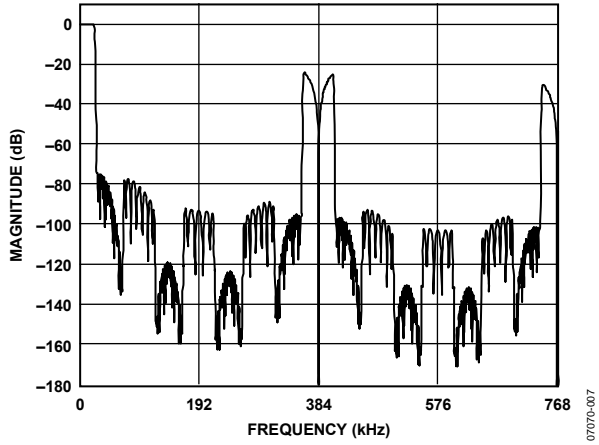

Figure 10. DAC Composite Filter Response (48 kHz)

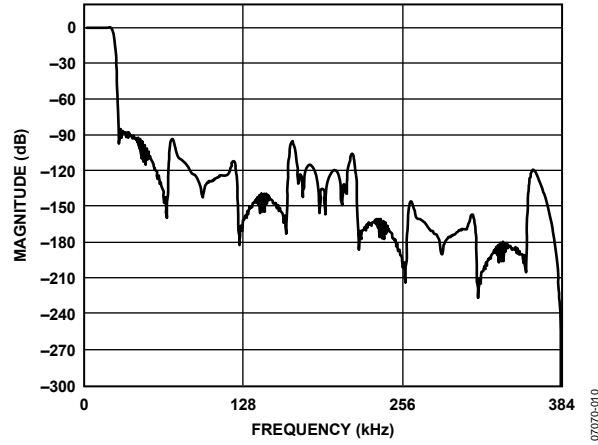

Figure 13. ADC Composite Filter Response (48 kHz)

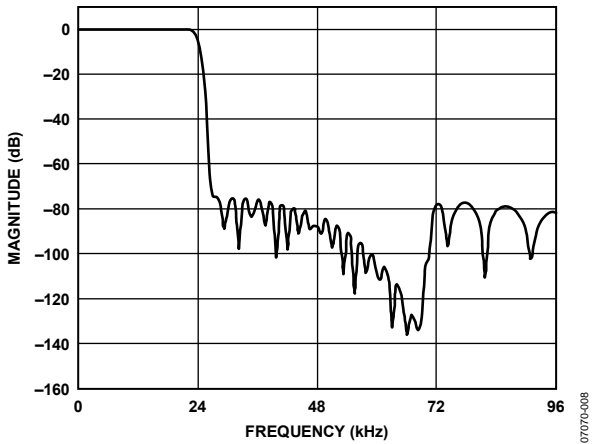

Figure 11. DAC Pass-Band Filter Response (48 kHz)

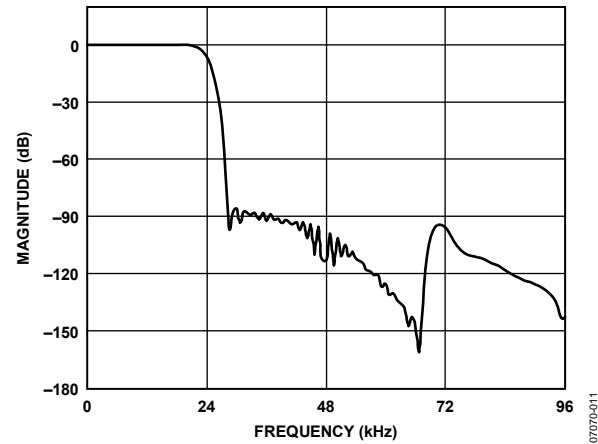

Figure 14. ADC Pass-Band Filter Response (48 kHz)

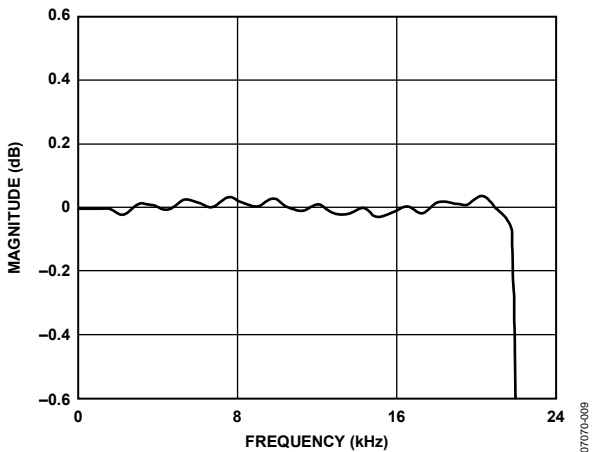

Figure 12. DAC Pass-Band Ripple (48 kHz)

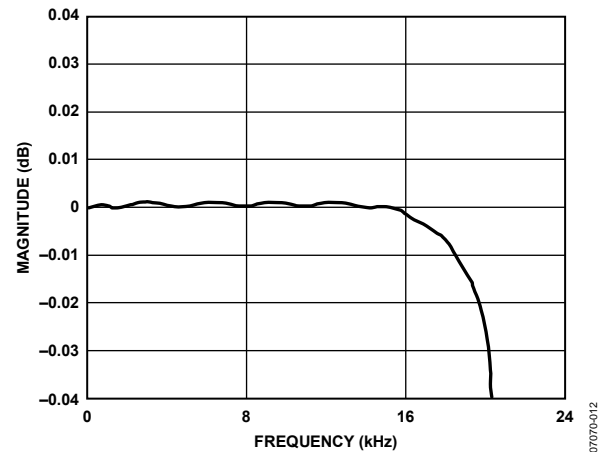

Figure 15. ADC Pass-Band Ripple (48 kHz)

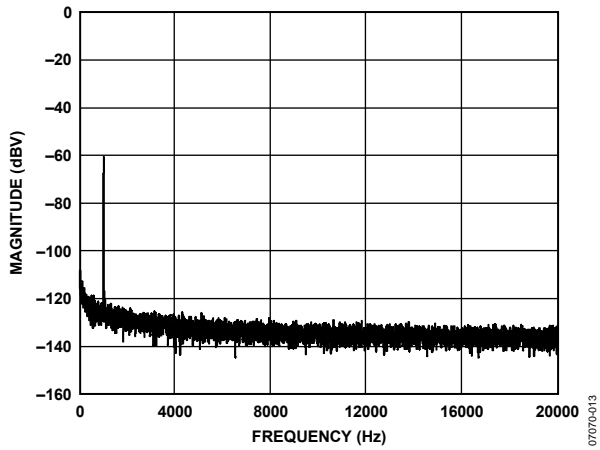

Figure 16. DAC Dynamic Range

07070-013

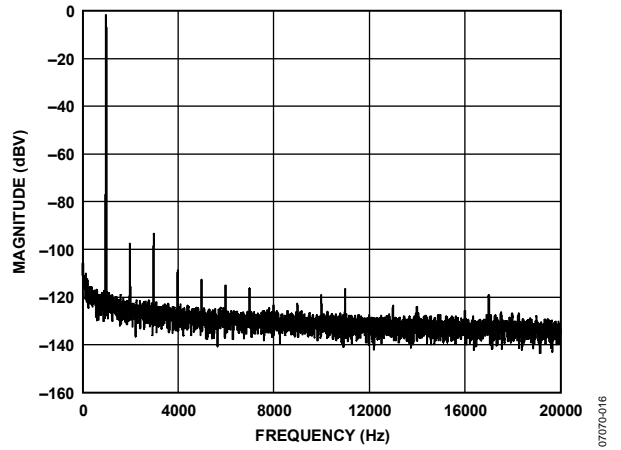

Figure 19. ADC Total Harmonic Distortion + Noise

07070-016

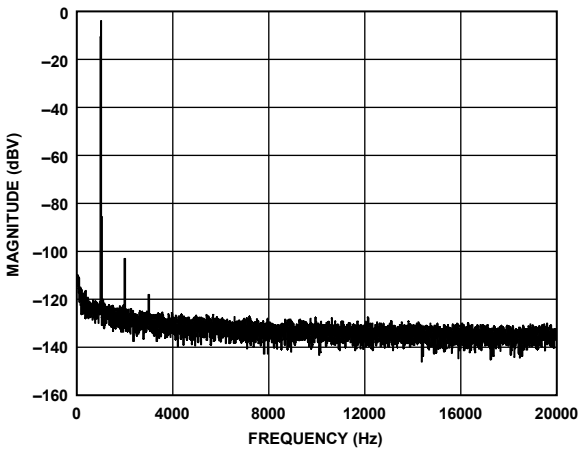

Figure 17. DAC Total Harmonic Distortion + Noise

07070-014

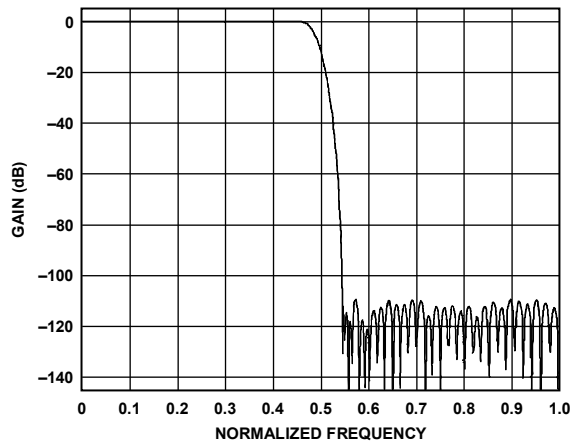

Figure 20. Sample Rate Converter Transfer Function

07070-017

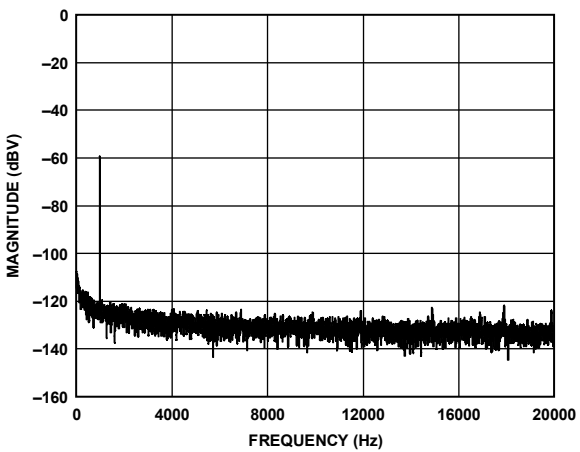

Figure 18. ADC Dynamic Range

07070-015

## TERMINOLOGY

### Dynamic Range

The ratio of a full-scale input signal to the integrated input noise in the pass band (20 Hz to 20 kHz), expressed in decibels (dB). Dynamic range is measured with a  $-60$  dB input signal and is equal to  $(S/[THD+N]) + 60$  dB. Note that spurious harmonics are below the noise with a  $-60$  dB input; therefore, the noise level establishes the dynamic range. The dynamic range is specified with and without an A-weight filter applied.

### Pass Band

The region of the frequency spectrum unaffected by the attenuation of the filter of the digital decimator.

### Pass-Band Ripple

The peak-to-peak variation in amplitude response from equal amplitude input signal frequencies within the pass band, expressed in decibels.

### Stop Band

The region of the frequency spectrum attenuated by the filter of the digital decimator to the degree specified by stop-band attenuation.

### Gain Error

With a near full-scale input, the ratio of the actual output to the expected output, expressed in dB.

### Interchannel Gain Mismatch

With identical near full-scale inputs, the ratio of the outputs of the two stereo channels, expressed in decibels.

### Crosstalk

Ratio of response on one channel with a grounded input to a full-scale 1 kHz sine wave input on the other channel, expressed in decibels.

### Power Supply Rejection

With no analog input, the signal present at the output when a 300 mV p-p signal is applied to power supply pins, expressed in decibels of full scale.

### Group Delay

Intuitively, the time interval required for an input pulse to appear at the output of the converter, expressed in milliseconds (ms); more precisely, the derivative of radian phase with respect to radian frequency at a given frequency.

## PIN FUNCTIONS

### DETAILED PIN DESCRIPTIONS

Table 5 shows the pin numbers, mnemonics, and descriptions for the ADAV4601. The input pins have a logic threshold compatible with 3.3 V input levels.

#### ***SDIN0, SDIN1, SDIN2, and SDIN3/SPDIF\_IN0***

Serial data inputs. These input pins provide the digital audio data to the signal processing core. Any of the inputs can be routed to either of the SRCs for conversion; this input is then not available as a synchronous input to the audio processor but only as an input through the selected SRC. The serial format for the synchronous data is selected by Bits[3:2] of the Serial Port Control Register 1. If the SRCs are required, the serial format is selected by Bits[12:9] of the same register. The synchronous inputs are capable of using any pair of serial clocks, LRCLK0/BCLK0, LRCLK1/BCLK1, or LRCLK2/BCLK2. By default, they use LRCLK1 and BCLK1. See Figure 26 for more details regarding the configuration of the synchronous inputs.

SDIN3 is a shared pin with SPDIF\_IN0. If SDIN3 is not in use, this pin can be used to connect an S/PDIF signal from an external source, such as an MPEG decoder, to the ADAV4601 on-chip S/PDIF output multiplexer. If SPDIF\_OUT is selected from one of the SPDIF\_IN (external) signals, the signal is simply passed through from input to output.

#### ***LRCLK0/SPDIF\_IN1, BCLK0/SPDIF\_IN2, LRCLK1/SPDIF\_IN3, BCLK1/SPDIF\_IN4, LRCLK2/SPDIF\_IN5, and BCLK2/SPDIF\_IN6***

By default, LRCLK1 and BCLK1 are associated with the synchronous inputs, LRCLK0 and BCLK0 are associated with SRC1, and LRCLK2 and BCLK2 are associated with SRC2. However, the SRCs and synchronous inputs can use any of the serial clocks (see Figure 26). LRCLK0, BCLK0, LRCLK1, BCLK1, LRCLK2, and BCLK2 are shared pins with SPDIF\_IN1, SPDIF\_IN2, SPDIF\_IN3, SPDIF\_IN4, SPDIF\_IN5, and SPDIF\_IN6, respectively. If LRCLK0/LRCLK1/ LRCLK2 or BCLK0/BCLK1/BCLK2 are not in use, these pins can be used to connect an S/PDIF signal from an external source, such as an MPEG decoder, to the ADAV4601 on-chip S/PDIF output multiplexer. If SPDIF\_OUT is selected from one of the SPDIF\_IN (external) signals, the signal is simply passed through from input to output.

#### ***SDO0/AD0***

Serial data output. This pin can output two channels of digital audio using a variety of standard 2-channel formats. The clocks for SDO0 are always the same as those used by the synchronous inputs; therefore, LRCLK1 and BCLK1 are used by default, although SDO0 is capable of using any pair of serial clocks, LRCLK0/BCLK0, LRCLK1/BCLK1, or LRCLK2/BCLK2. The Serial Port Control Register 1 selects the serial format for the synchronous output. On reset, the SDO0 pin duplicates as the I<sup>2</sup>C<sup>®</sup> address select pin. In this mode, the logical state of the pin is polled for four MCLKI cycles following reset. The address select bit is set as the majority poll of the logic level of the pin after the four MCLKI cycles.

#### ***SPDIF\_OUT/SDO1***

The ADAV4601 contains an S/PDIF multiplexer functionality that allows the SPDIF\_OUT signal to be chosen from an internally generated S/PDIF signal or from the S/PDIF signal of an external source, which is connected via one of the SPDIF\_IN pins. This pin can also be configured as an additional serial output (SDO1) as an alternate function.

#### ***MCLKI/XIN***

Master clock input. The ADAV4601 uses a PLL to generate the appropriate internal clock for the audio processing core. A clock signal of a suitable frequency can be connected directly to this pin, or a crystal can be connected between MCLKI/XIN and XOUT together with the appropriate capacitors to DGND to generate a suitable clock signal.

#### ***XOUT***

This pin is used in conjunction with MCLKI/XIN to generate a clock signal for the ADAV4601.

#### ***MCLK\_OUT***

This pin can be used to output MCLKI or one of the internal system clocks. Note that the output level of this pin is referenced to DVDD (1.8 V) and not ODVDD (3.3 V) like all the other digital inputs and outputs.

#### ***SDA***

Serial data input for the I<sup>2</sup>C control port. SDA features a glitch elimination filter that removes spurious pulses that are less than 50 ns wide.

# ADAV4601

## **SCL**

Serial clock for the I<sup>2</sup>C control port. SCL features a glitch elimination filter that removes spurious pulses that are less than 50 ns wide.

## **MUTE**

Mute input request. This active-low input pin controls the muting of the output ports (both analog and digital) from the ADAV4601. When low, it asserts mute on the outputs that are enabled in the audio flow.

## **RESET**

Active-low reset signal. After  $\overline{\text{RESET}}$  goes high, the circuit blocks are powered down. The blocks can be individually powered up with software. When the part is powered up, it takes approximately 3072 internal clocks to initialize the internal circuitry. The internal system clock is equal to MCLKI until the PLL is powered and enabled, after which the internal system clock becomes  $2560 \times f_s$  (122.88 MHz). When the PLL is powered up and enabled after reset, it takes approximately 3 ms to lock. When the audio processor is enabled, it takes approximately 32,768 internal system clocks to initialize and load the default flow to the audio processor memory. The audio processor is not available during this time.

## **AUXIN1L AND AUXIN1R**

Analog inputs to the on-chip ADCs.

## **AUXOUT1L, AUXOUT1R, AUXOUT3L, AUXOUT3R, AUXOUT4L, and AUXOUT4R**

Auxiliary DAC analog outputs. These pins can be programmed to supply the outputs of the internal audio processing for line out or record use.

## **HPOUT1L and HPOUT1R**

Analog outputs from the headphone amplifiers.

## **PLL\_LF**

PLL loop filter connection. A 100 nF capacitor and a 2 k $\Omega$  resistor in parallel with a 1 nF capacitor tied to AVDD are required for the PLL loop filter to operate correctly.

## **VREF**

Voltage reference for DACs and ADCs. This pin is driven by an internal 1.5 V reference voltage.

## **FILTA and FILTD**

Decoupling nodes for the ADC and DAC. Decoupling capacitors should be connected between these nodes and AGND, typically 47  $\mu\text{F}$  in parallel with 0.1  $\mu\text{F}$  and 10  $\mu\text{F}$  in parallel with 0.1  $\mu\text{F}$ , respectively.

## **PWM1A, PWM1B, PWM2A, PWM2B, PWM3A, PWM3B, PWM4A, and PWM4B**

Differential pulse-width modulation outputs are suitable for driving Class-D amplifiers.

## **PWM\_READY**

This pin is set high when PWM is enabled and stable.

## **AVDD**

Analog power supply pins. These pins should be connected to 3.3 V. Each AVDD pin should be decoupled with a 0.1  $\mu\text{F}$  capacitor to AGND, as close to the pin as possible. In addition, the ADC supply (Pin 4) and the DAC supplies (Pin 68 and Pin 71) should share a 10  $\mu\text{F}$  capacitor to ground. The PLL supply (Pin 53) should have an additional 1 nF and 10  $\mu\text{F}$  capacitor to ground, and the headphone supply (Pin 59) should have an additional 10  $\mu\text{F}$  capacitor to ground.

## **DVDD**

Digital power supply pins. These pins should be connected to a 1.8 V digital supply. For optimal performance, each DVDD/DGND pair requires a 0.1  $\mu\text{F}$  decoupling capacitor as close to the pin as possible. In addition, these 0.1  $\mu\text{F}$  decoupling capacitors are in parallel with a single 10  $\mu\text{F}$  capacitor.

## **ODVDD**

Digital interface power supply pin. Connect this pin to a 3.3 V digital supply. Decouple this pin with 10  $\mu\text{F}$  and 0.1  $\mu\text{F}$  capacitors to DGND, as close to the pin as possible.

## **DGND**

Digital ground.

## **AGND**

Analog ground.

## **ODGND**

Ground for the digital interface power supply.

## **ISET**

ADC current setting resistor. See the ADC Inputs section for more details.



## FUNCTIONAL DESCRIPTIONS

### POWER-UP SEQUENCE

The following sequence provides an overview of how to initialize the IC:

1. Apply power to the ADAV4601.
2. Enable PLL via an I<sup>2</sup>C write and wait 15 ms for PLL to lock.
3. Power up via an I<sup>2</sup>C write to the global power-up bit in the initialization control register (0x0000).
4. A default flow is automatically loaded on power-up. If a user-defined flow is loaded, see the Loading a Custom Audio Processing Flow section for additional information.
5. Depending on the I/O blocks required, other steps may need to be taken; for example, headphone outputs may need to be tristated. See the ADC Inputs, DAC Voltage Outputs, PWM Outputs, Headphone Output and S/PDIF Input/Output sections that describe the I/O blocks in detail.
6. Unmute.

### MASTER CLOCK OSCILLATOR

Internally, the ADAV4601 operates synchronously to the master MCLKI input. All internal system clocks are generated from this single clock input using an internal PLL. This MCLKI input can also be generated by an external crystal oscillator connected to the MCLKI/XIN pin or by using a simple crystal oscillator connected across MCLKI/XIN and XOUT. By default, the master clock frequency is 24.576 MHz; however, by using the internal dividers, an MCLKI of 12.288 MHz, 6.144 MHz, and 3.072 MHz are also supported.

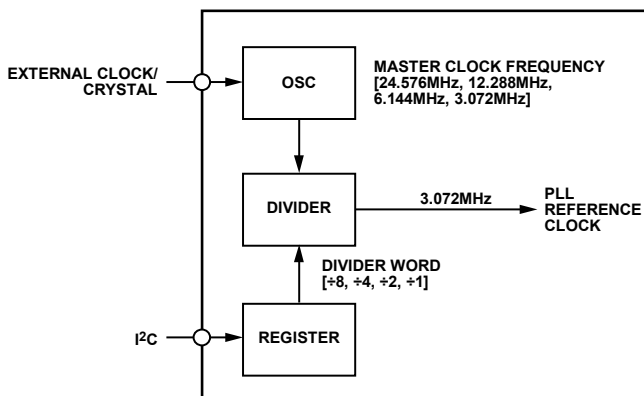

Figure 21. Master Clock

Figure 22 shows the external circuit recommended for proper operation when using a crystal oscillator. Due to the effect of stray capacitance, consideration must be given to the value of C1 and C2 when calculating the desired C<sub>LOAD</sub> for the crystal.

$$C_{LOAD} = \frac{(C_{pg1} + C1)(C_{pg2} + C2)}{C_{pg1} + C1 + C_{pg2} + C2} + C_S$$

where:

C<sub>pg1</sub> and C<sub>pg2</sub> are the pin to ground capacitances.

C<sub>S</sub> is the PCB stray capacitance.

A good rule of thumb is to approximate C<sub>pg1</sub> and C<sub>pg2</sub> to be between 5 pF and 10 pF and C<sub>S</sub> to be between 2 pF and 3 pF.

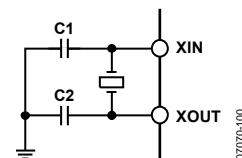

Figure 22. Circuit for Crystal Resonator

### I<sup>2</sup>C INTERFACE

The ADAV4601 supports a 2-wire serial (I<sup>2</sup>C compatible) microprocessor bus driving multiple peripherals. The ADAV4601 is controlled by an external I<sup>2</sup>C master device, such as a microcontroller. The ADAV4601 is in slave mode on the I<sup>2</sup>C bus, except during self-boot. While the ADAV4601 is self-booting, it becomes the master, and the EEPROM, which contains the ROMs to be booted, is the slave. When the self-boot process is complete, the ADAV4601 reverts to slave mode on the I<sup>2</sup>C bus. No other devices should access the I<sup>2</sup>C bus while the ADAV4601 is self-booting (refer to the Application Layer section and the Loading a Custom Audio Processing Flow section).

Initially, all devices on the I<sup>2</sup>C bus are in an idle state, wherein the devices monitor the SDA and SCL lines for a start condition and the proper address. The I<sup>2</sup>C master initiates a data transfer by establishing a start condition, defined by a high-to-low transition on SDA while SCL remains high. This indicates that an address/data stream follows. All devices on the bus respond to the start condition and read the next byte (7-bit address plus the R/W bit) MSB first. The device that recognizes the transmitted address responds by pulling the data line low during the ninth clock pulse. This ninth bit is known as an acknowledge bit.

All other devices on the bus revert to an idle condition. The R/W bit determines the direction of the data. A Logic Level 0 on the LSB of the first byte means the master writes information to the peripheral. A Logic Level 1 on the LSB of the first byte means the master reads information from the peripheral. A data transfer takes place until a stop condition is encountered. A stop condition occurs when SDA transitions from low to high while SCL is held high.

The ADAV4601 determines its I<sup>2</sup>C device address by sampling the SDO0 pin after reset. Internally, the SDO0 pin is sampled by four MCLKI edges to determine the state of the pin (high or low). Because the pin has an internal pull-down resistor default, the address of the ADAV4601 is 0x34 (write) and 0x35 (read). An alternate address, 0x36 (write) and 0x37 (read), is available by tying the SDO0 pin to ODVDD via a 10 kΩ resistor. The I<sup>2</sup>C interface supports a clock frequency of up to 400 kHz.

# ADAV4601

**Table 6. Single Word I<sup>2</sup>C Write<sup>1</sup>**

S	Chip address, R/W = 0	AS	Subaddress high	AS	Subaddress low	AS	Data Byte 1	AS	Data Byte 2	...	AS	Data Byte N	P
---	-----------------------	----	-----------------	----	----------------	----	-------------	----	-------------	-----	----	-------------	---

<sup>1</sup> S = start bit, P = stop bit, and AS = acknowledge by slave.

**Table 7. Burst Mode I<sup>2</sup>C Write<sup>1</sup>**

S	Chip address, R/W = 0	AS	Subaddress high	AS	Subaddress low	AS	Data-Word 1, Byte 1	AS	Data-Word 1, Byte 2	AS	Data-Word 2, Byte 1	AS	Data-Word 2, Byte 2	AS	...	P
---	-----------------------	----	-----------------	----	----------------	----	---------------------	----	---------------------	----	---------------------	----	---------------------	----	-----	---

<sup>1</sup> S = start bit, P = stop bit, and AS = acknowledge by slave.

**Table 8. Single Word I<sup>2</sup>C Read<sup>1</sup>**

S	Chip address, R/W = 0	AS	Subaddress high	AS	Subaddress low	AS	S	Chip address, R/W = 1	AS	Data Byte 1	AM	Data Byte 2	...	AM	Data Byte N	P
---	-----------------------	----	-----------------	----	----------------	----	---	-----------------------	----	-------------	----	-------------	-----	----	-------------	---

<sup>1</sup> S = start bit, P = stop bit, AM = acknowledge by master, and AS = acknowledge by slave.

**Table 9. Burst Mode I<sup>2</sup>C Read<sup>1</sup>**

S	Chip address, R/W = 0	AS	Subaddress high	AS	Subaddress low	AS	S	Chip address, R/W = 1	AS	Data-Word 1 Byte 1	AM	Data-Word 1 Byte 2	AM	...	P
---	-----------------------	----	-----------------	----	----------------	----	---	-----------------------	----	--------------------	----	--------------------	----	-----	---

<sup>1</sup> S = start bit, P = stop bit, AM = acknowledge by master, and AS = acknowledge by slave.

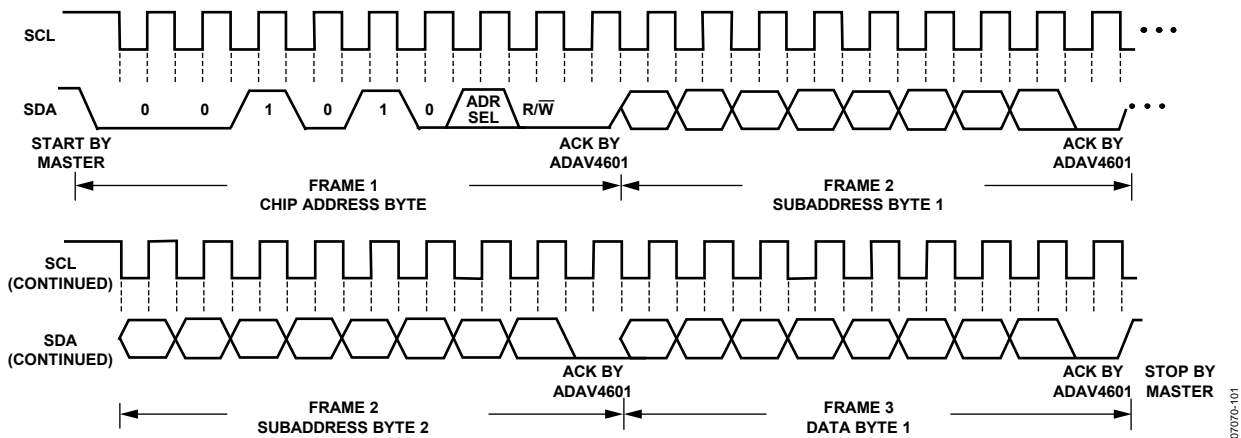

Figure 23. I<sup>2</sup>C Write Format

07070-101

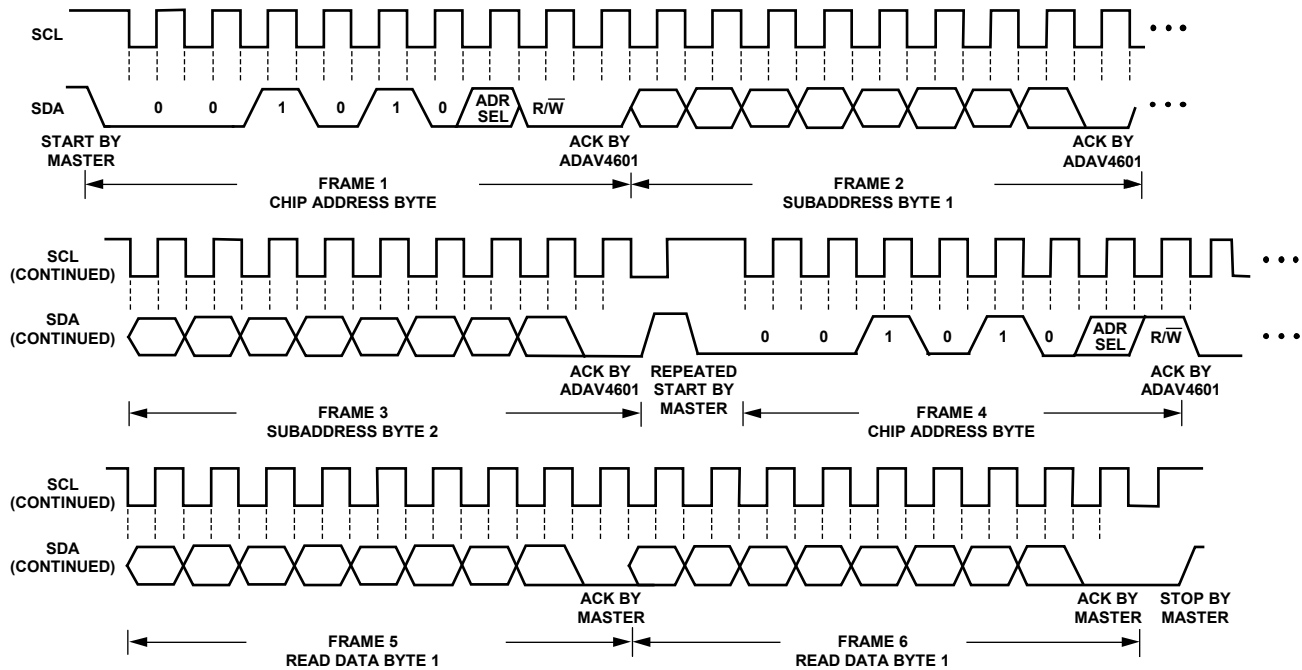

Figure 24. I<sup>2</sup>C Read Format

**I<sup>2</sup>C READ AND WRITE OPERATIONS**

Table 6 shows the timing of a single word write operation. Every ninth clock, the ADAV4601 issues an acknowledge by pulling SDA low.

Table 7 shows the timing of the burst mode write sequence. Table 7 shows an example where the target destination registers are two bytes. The ADAV4601 auto-increments its subaddress register counter every two bytes until a stop condition occurs.

The timing of a single word read operation is shown in Table 8. Note that the first R/W bit is still 0, indicating a write operation. This is because the subaddress must be written to set up the internal address. After the ADAV4601 acknowledges the receipt of the subaddress, the master must issue a repeated start command followed by the chip address byte with the R/W set to 1 (read). The ADAV4601 responds with the read result on SDA. The master then responds every ninth clock with an acknowledge pulse to the ADAV4601.

Table 9 shows the timing of the burst mode read sequence. Table 9 shows an example where the target read registers are two bytes. The ADAV4601 increments its subaddress register every two bytes because the requested subaddress corresponds to a register or memory area with word lengths of two bytes. Other address ranges may have a variety of word lengths ranging from one to six bytes; the ADAV4601 always decodes the subaddress and sets the auto-increment circuit so that the address increments after the appropriate number of bytes.

**ADC INPUTS**

The ADAV4601 has two ADC inputs. By default, this is configured as a single stereo input; however, because the audio processor is programmable, these inputs can be reconfigured.

The ADC inputs are shown in Figure 25. The analog inputs are current inputs (100 μA rms FS) with a 1.5 V dc bias voltage. Any input voltage can be accommodated by choosing a suitable combination of input resistor (R<sub>IN</sub>) and ISET resistor (R<sub>ISET</sub>) using the formulas

$$R_{IN} = V_{FS\ rms}/100\ \mu A\ rms$$

$$R_{ISET} = 2R_{IN}/V_{IN}$$

Resistor matching (typically 1%) between R<sub>IN</sub> and R<sub>ISET</sub> is important to ensure a full-scale signal on the ADC without clipping. A 10 μF dc blocking capacitor is also required at the input.

After reset, the ADCs are in a power-down state. The ADCs can be powered up using the global power-up in the initialization control register (0x0000). In power critical applications, it is possible to use the analog power management register (0x0005) to power-up or power-down individual ADCs.

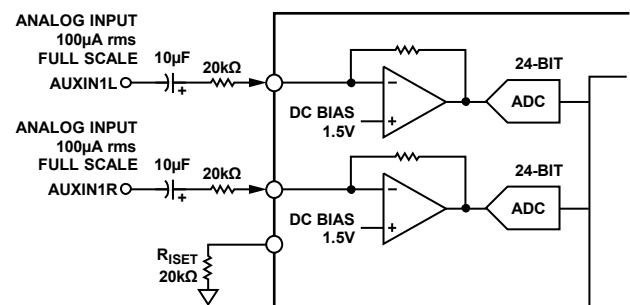

Figure 25. Analog Input Section

## I<sup>2</sup>S DIGITAL AUDIO INPUTS

The ADAV4601 has four I<sup>2</sup>S digital audio inputs that are, by default, synchronous to the master clock. Also available are two SRCs capable of supporting any nonsynchronous input with a sample rate between 5 kHz and 50 kHz. Any of the serial digital inputs can be redirected through the SRC. Figure 26 shows a block diagram of the input serial port.

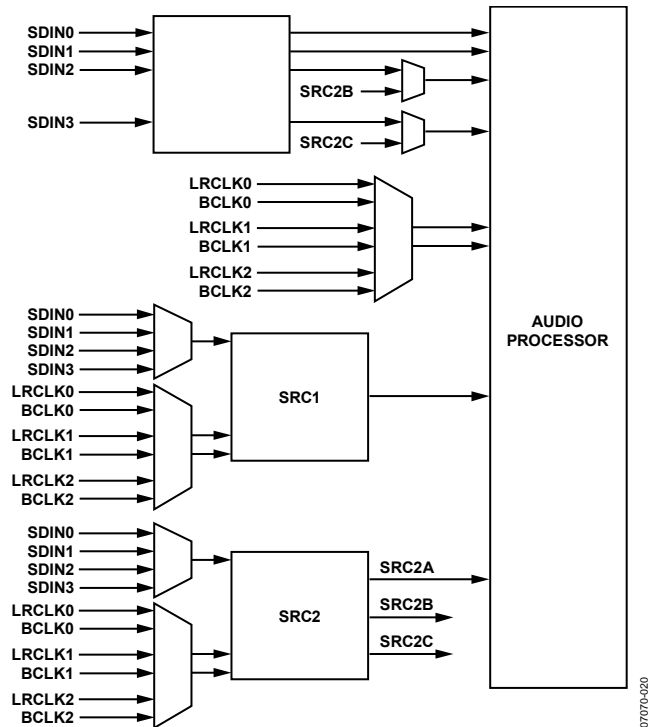

Figure 26. Digital Input Section

## Synchronous Inputs and Outputs

The synchronous digital inputs and outputs can use any of the BCLK or LRCLK inputs as a clock and framing signal. By default, BCLK1 and LRCLK1 are the serial clocks used for the synchronous inputs. The synchronous port for the ADAV4601 is in slave mode by default, which means the user must supply the appropriate serial clocks, BCLK and LRCLK. The synchronous port can also be set to master mode, which means that the appropriate serial clocks, BCLK and LRCLK, can be generated internally from the MCLK; therefore, the user does not need to provide them. The serial data inputs are capable of accepting all of the popular audio transmission standards (see the Serial Data Interface section for more details).

## Asynchronous Inputs

The ADAV4601 has two SRCs, SRC1 and SRC2, that can be used for converting digital data, which is not synchronous to the master clock. Each SRC can accept input sample rates in the range of 5 kHz to 50 kHz. Data that has been converted by the SRC is input to the part and is then synchronous to the internal audio processor.

The SRC1 is a 2-channel (single-stereo) sample rate converter that is capable of using any of the three serial clocks available. The SRC1 can accept data from any of the serial data inputs (SDIN0, SDIN1, SDIN2, and SDIN3). When selected as an input to the SRC, this SDIN line is assumed to contain asynchronous data and is then masked as an input to the audio processor to ensure that asynchronous data is not processed as synchronous data. By default, SRC1 uses the LRCLK0 and BCLK0 as the clock and framing signals.

The SRC2 is a 6-channel (3-stereo) sample rate converter that is capable of using any of the three serial clocks available. The SRC2 can accept data from any of the serial data inputs (SDIN0, SDIN1, SDIN2, and SDIN3). When selected as an input to the SRC, this SDIN line is assumed to contain asynchronous data and is then masked internally as an input to the audio processor to ensure that asynchronous data is not processed as synchronous data. By default, SRC2 uses the LRCLK2 and BCLK2 as the clock and framing signals.

The first output (SRC2A) from SRC2 is always available to the audio processor. The other two outputs are muxed with two of the serial inputs before being available to the audio processor. SRC2B is muxed with SDIN2, and SRC2C is muxed with SDIN3. By default, these muxes are configured so that the synchronous inputs are available to the audio processor. The SRC2B and SRC2C channels can be made available to the audio processor simply by enabling them by register write.

When using the ADAV4601 in an asynchronous digital-in-to-digital-out configuration, the input digital data is input to the audio processor core from one of the SRCs, using the assigned BCLK/LRCLK as a framing signal. The digital output is synchronous to the BCLK/LRCLK, which is assigned to the synchronous port; the default clock in this case is BCLK1 and LRCLK1.

## Serial Data Interface

LRCLK is the framing signal for the left- and right-channel inputs, with a frequency equal to the sampling frequency ( $f_s$ ).

BCLK is the bit clock for the digital interface, with a frequency of  $64 \times f_s$  (32 BCLK periods for each of the left and right channels).

The serial data interface supports all the popular audio interface standards, such as I<sup>2</sup>S, left-justified (LJ), and right-justified (RJ). The interface mode is software selectable, and its default is I<sup>2</sup>S. The data sample width is also software selectable from 16 bits, 20 bits, or 24 bits. The default is 24 bits.

**I<sup>2</sup>S Mode**

In I<sup>2</sup>S mode, the data is left-justified, MSB first, with the MSB placed in the second BCLK period following the transition of the LRCLK. A high-to-low transition of the LRCLK signifies the beginning of the left channel data transfer, and a low-to-high transition on the LRCLK signifies the beginning of the right channel data transfer (see Figure 27).

**Left-Justified (LJ) Mode**

In LJ mode, the data is left-justified, MSB first, with the MSB placed in the first BCLK period following the transition of the LRCLK. A high-to-low transition of the LRCLK signifies the beginning of the right-channel data transfer, and a low-to-high transition on the LRCLK signifies the beginning of the left-channel data transfer (see Figure 28).

**Right-Justified (RJ) Mode**

In RJ mode, the data is right-justified, LSB last, with the LSB placed in the last BCLK period preceding the transition of LRCLK. A high-to-low transition of the LRCLK signifies the beginning of the right-channel data transfer, and a low-to-high transition on the LRCLK signifies the beginning of the left-channel data transfer (see Figure 29).

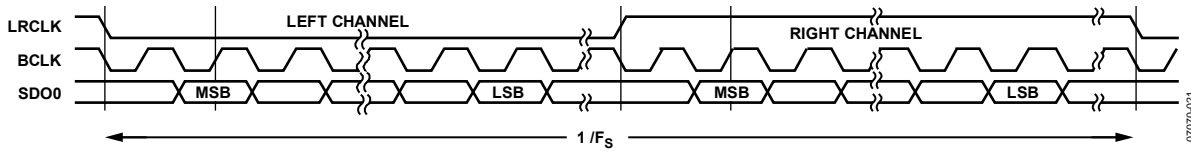

Figure 27. I<sup>2</sup>S Mode

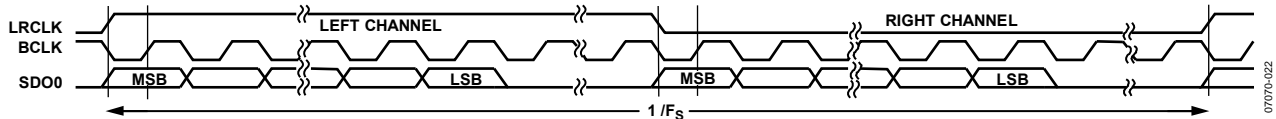

Figure 28. Left-Justified Mode

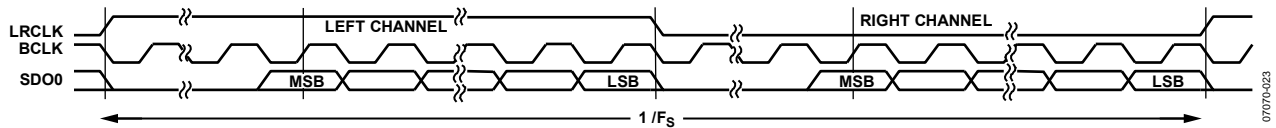

Figure 29. Right-Justified Mode

# ADAV4601

## DAC VOLTAGE OUTPUTS

The ADAV4601 has six DAC outputs, configured as 3-stereo auxiliary DAC outputs. However, because the flow is customizable, it is programmable. The output level is 1 V rms full scale. The DAC outputs should have a 10 nF capacitor to ground for filtering out high frequency noise. Following the filtering capacitor, a 10  $\mu$ F is required for dc blocking.

After reset, the DACs are in a power-down state. They can power up quickly using the global power-up in the initialization control register (0x0000). A popless and clickless power-up and power-down are also possible.

In power critical applications, it is possible to use the Analog Power Management 1 register (0x0005) to power up or power down individual DACs.

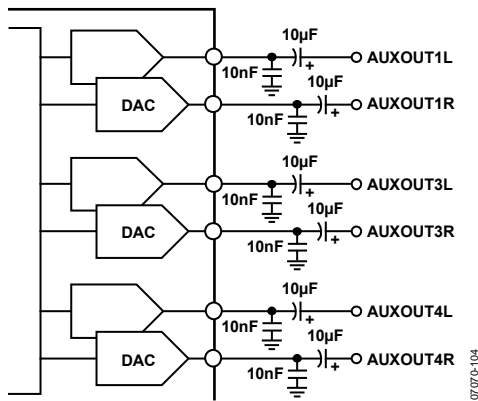

Figure 30. DAC Output Section

## PWM OUTPUTS

In the ADAV4601, the main outputs are available as four PWM output channels, which are suitable for driving Class-D amplifiers.

After reset, the PWM channels are in a power-down state. Writing to the miscellaneous control register (0x000A) enables the PWM channels. To help ensure popless and clickless power-up and power-down, there is an enable/disable pattern that is specially constructed to bring the PWM channels from a zero condition to a 50/50 duty-cycle square wave (effectively, a zero signal into the PWM block). This takes 365 ms to complete and can be seen in Figure 33.

Designed for use in conjunction with this ramp-up scheme, the ADAV4601 features a status pin, PWM\_READY, that indicates when the PWM outputs are in a state that can cause pops/clicks,

such as power-up and power-down. During PWM power-up and power-down, this pin remains low to signify that the outputs are not in a valid state. This functionality helps to eliminate pop/click and other unwanted noise on the outputs.

To accommodate different power stages, the point at which the PWM\_READY signal goes high is programmable. It can go high when the PWM outputs begin their ramp-up scheme (PWM\_READY early), or it can be programmed to go high when this ramp-up scheme is complete (PWM\_READY late). This is shown in Figure 33, and it is configured in the PWM control register (0x001F).

Each set of PWM outputs comprises complementary outputs. The modulation frequency is 384 kHz, and the full-scale duty cycle has a ratio of 97:3.

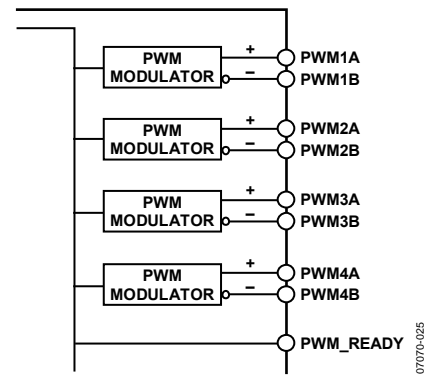

Figure 31. PWM Output Section

## HEADPHONE OUTPUT

There is a dedicated stereo headphone amplifier output that is capable of driving 32  $\Omega$  loads at 1 V rms.

After reset, the headphone output is tristated. The tristate is disabled using the headphone control register (0x000B). Using the same register, the gain of the headphone amplifier can be set in +1.5 dB steps from +1.5 dB to -45 dB. The headphone output should have a 10  $\mu$ F capacitor for dc blocking.

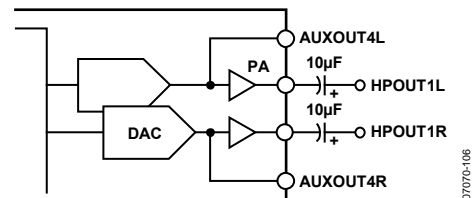

Figure 32. Headphone Output Section

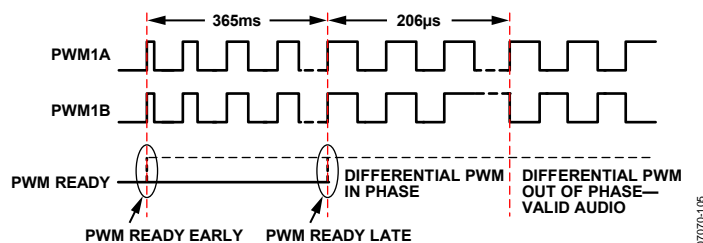

Figure 33. PWM Early

### I<sup>2</sup>S DIGITAL AUDIO OUTPUTS

One I<sup>2</sup>S output, SDO0, uses the same serial clocks as the serial inputs, which are BCLK1 and LRCLK1 by default. If an additional digital output is required, an additional pin can be reconfigured as a serial digital output, as shown in Figure 34.

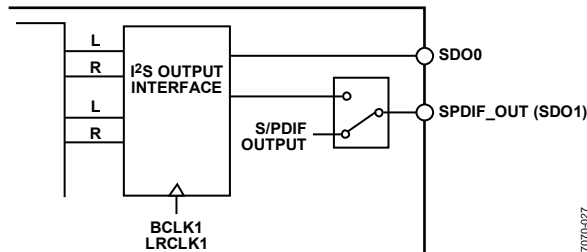

Figure 34. I<sup>2</sup>S Digital Outputs

07070-027

### S/PDIF INPUT/OUTPUT

The S/PDIF output (SPDIF\_OUT/SDO1) uses a multiplexer to select an output from the audio processor or to pass through the unprocessed SPDIF\_IN signals, as shown in Figure 35. On the ADAV4601, the S/PDIF inputs, SPDIF\_IN0/SPDIF\_IN1/SPDIF\_IN2/SPDIF\_IN3/SPDIF\_IN4/SPDIF\_IN5/SPDIF\_IN6, are available on the SDIN3, LRCLK0, BCLK0, LRCLK1, BCLK1, LRCLK2, and BCLK2 pins, respectively. It is possible to have all seven S/PDIF inputs connected to different S/PDIF signals at one time. A consequence of this setup is that none of the LRCLKs and BCLKs are available for use with the digital inputs SDIN0, SDIN1, SDIN2, and SDIN3. If there is only one S/PDIF input in use, using the SDIN3 pin as the dedicated S/PDIF input is recommended; this enables BCLK0/LRCLK0, BCLK1/LRCLK1, and BCLK2/LRCLK2 to be used as the clock and framing signals for the synchronous and asynchronous port. If SDIN3 is used as an S/PDIF input, it should not be used internally as an input to the audio processor because it contains invalid data. Similarly, if BCLK or LRCLK is used as the S/PDIF input, they can no longer be used as the lock and framing signals for SDIN0, SDIN1, SDIN2, and SDIN3. The S/PDIF encoder supports only consumer formats that conform to IEC-600958.

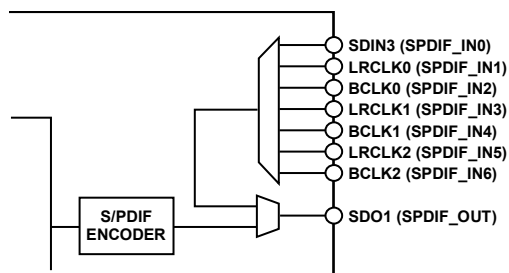

Figure 35. S/PDIF Output

07070-028

### HARDWARE MUTE CONTROL

The ADAV4601 mute input can be used to mute any of the analog or digital outputs. When the MUTE pin goes low, the selected outputs ramp to a muted condition. Unmuting is handled in one of two ways and depends on the register setting.

By default, the MUTE pin going high causes the outputs to immediately ramp to an unmuted state. However, it is also possible to have the unmute operation controlled by a control register bit. In this scenario, even if the MUTE pin goes high, the device does not unmute until a bit in the control register is set. This can be used when the user wants to keep the outputs muted, even after the pin has gone high again, for example, in the case of a fault condition. This allows the system controller total control over the unmute operation.

### AUDIO PROCESSOR

The internal audio processor runs at  $2560 \times f_s$ ; at 48 kHz, this is 122.88 MHz. Internally, the word size is 28 bits, which allows 24 dB of headroom for internal processing. Designed specifically with audio processing in mind, it can implement complex audio algorithms efficiently.

By default, the ADAV4601 loads a default audio flow, as shown in Figure 48. However, because the audio processor is fully programmable, a custom audio flow can be quickly developed and loaded to the audio processor.

The audio flow is contained in program RAM and parameter RAM. Program RAM contains the instructions to be processed by the audio processor, and parameter RAM contains the coefficients that control the flow, such as volume control, filter coefficients, and enable bits.

### GRAPHICAL PROGRAMMING ENVIRONMENT

Custom flows for the ADAV4601 are created in a powerful drag-and-drop graphical programming application called SigmaStudio. No knowledge of assembly code is required to program the ADAV4601. Featuring a comprehensive library of audio processing blocks (such as filters, delays, dynamics processors, and third-party algorithms), sigma studio allows a quick and simple creation of custom flows. For debugging purposes, run-time control of the audio flow allows the user to fully configure and test the created flow.

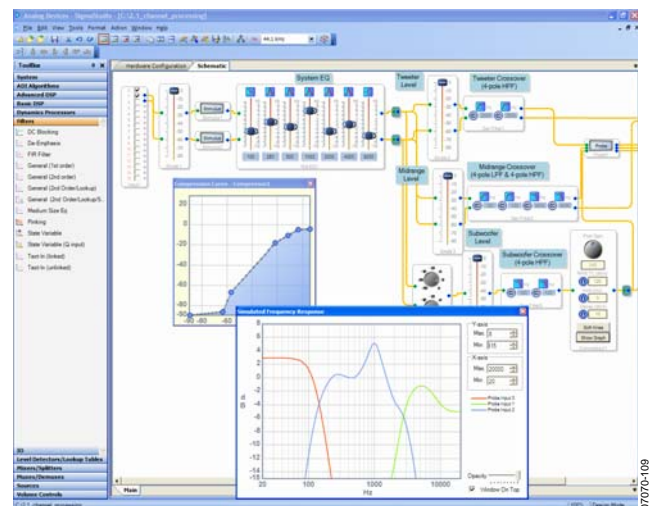

Figure 36. SigmaStudio Window

07070-109

# ADAV4601

## SIGMASTUDIO PIN ASSIGNMENT

Inputs and outputs are defined as numbers in SigmaStudio. Each number corresponds to a physical input or output on the ADAV4601. Table 10 and Table 11 show these relationships.

**Table 10. Input Channels**

SigmaStudio Input	Pin Name
0	SDINL0
1	SDINR0
2	SDINL1
3	SDINR1
4	SDINL2/SRC2BL
5	SDINR2/SRC2BR
6	SDINL3/SRC2CL
7	SDINR3/SRC2CR
8	AUXIN1L
9	AUXIN1R
10, 11	No connect
12	SRC1L
13	SRC1R
14	SRC2AL
15	SRC2AR
16, 17	No connect

**Table 11. Output Channels**

Sigma Studio Output	Pin Name
0	SDOLO
1	SDOR0
2 to 7	No connect
8	PWM1/AUXOUT3L
9	PWM2/AUXOUT3R
10	AUXOUT4L/Headphone 1L
11	AUXOUT4R/Headphone 1R
12	AUXOUT1L
13	AUXOUT1R
14	PWM3
15	PWM4
16 to 19	No connect
20	SPDIF OUTL
21	SPDIF OUTR

## APPLICATION LAYER

Unique to the ADAV46xx family is the embedded application layer, which allows the user to define a custom set of registers to control the audio flow, greatly simplifying the interface between the audio processor and the system controller. This allows the ADAV4601 to appear as a simple fixed function register-based device to the system controller.

When a custom flow is created, a user-customized register map can be defined for controlling the flow. Each register is 16 bits, but controls can use only one bit or all 16 bits. Users have full control over which parameters they use and the degree of control they have over those parameters during run time. The combination of the graphical programming environment and the powerful application layer allows the user to quickly develop a custom audio flow and still maintain the usability of a simple register-based device.

## LOADING A CUSTOM AUDIO PROCESSING FLOW

The ADAV4601 can load a custom audio flow from an external I<sup>2</sup>C ROM. The boot process is initiated by a simple control register write. The EEPROM device address and the EEPROM start address for the audio flow ROMs can all be programmed.

For the duration of the boot sequence, the ADAV4601 becomes the master on the I<sup>2</sup>C bus. Transfer of the ROMs from the EEPROM to the ADAV4601 takes a maximum of 1.06 sec, assuming that the full audio processor memory is required, during which time no other devices should access the I<sup>2</sup>C bus. When the transfer is complete, the ADAV4601 automatically reverts to slave mode, and the I<sup>2</sup>C bus master can resume sending commands.

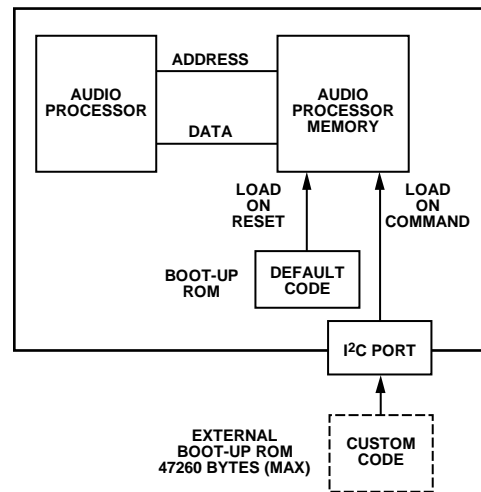

Figure 37. External EEPROM Booting

## NUMERIC FORMATS

It is common in DSP systems to use a standardized method of specifying numeric formats. Fractional number systems are specified by an A.B format, where A is the number of bits to the left of the decimal point and B is the number of bits to the right of the decimal point.

The ADAV4601 uses the same numeric format for both the coefficient values (stored in the parameter RAM) and the signal data values.

### Numeric Format: 5.23

It ranges from  $-16.0$  to  $(+16.0 - 1 \text{ LSB})$ .



**Examples**

- 1000 0000 0000 0000 0000 0000 = -16.0
- 1110 0000 0000 0000 0000 0000 = -4.0
- 1111 1000 0000 0000 0000 0000 = -1.0
- 1111 1110 0000 0000 0000 0000 = -0.25
- 1111 1111 1111 1111 1111 1111 = (1 LSB below 0.0)
- 0000 0000 0000 0000 0000 0000 = 0.0
- 0000 0010 0000 0000 0000 0000 = +0.25
- 0000 1000 0000 0000 0000 0000 = +1.0
- 0010 0000 0000 0000 0000 0000 = +4.0
- 0111 1111 1111 1111 1111 1111 = (+16.0 - 1 LSB)

The serial port accepts up to 24 bits on the input and is sign-extended to the full 28 bits of the DSP core. This allows internal gains of up to 24 dB without internal clipping.

A digital clipper circuit is used between the output of the DSP core and the DACs or serial port outputs (see Figure 38). This clips the top four bits of the signal to produce a 24-bit output with a range of +1.0 (minus 1 LSB) to -1.0. Figure 38 shows the maximum signal levels at each point in the data flow in both binary and decibel levels.

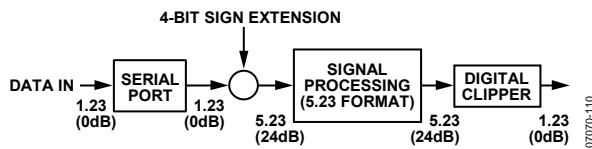

Figure 38. Numeric Precision and Clipping Structure

**ROMS AND REGISTERS**

The ADAV4601 contains four ROMs: program, instruction, parameter, and LUT. A default set of ROMs is stored on chip and is loaded on power-up. A set of ROMs defining a custom flow can be stored externally on an EEPROM and can be loaded after power-up.

**Program ROM**

Program ROM is 42-bits wide and occupies Address 0x1400 to Address 0x1FFF. This is where the audio flow generated in SigmaStudio is stored.

**Instruction ROM**

Instruction ROM is 33-bits wide and occupies Address 0x3000 to Address 0x327F. This is where the application layer register map is stored.

**Parameter ROM**

Parameter ROM is 28-bits wide and occupies Address 0x1000 to Address 0x13FF. Default parameters for default flow and custom flow are stored here.

**LUT ROM**

LUT ROM is 28-bits wide and occupies Address 0x4000 to Address 0x57FF. This contains the parameters for both flows combined.

**SAFE LOADING TO PARAMETER RAM AND TARGET/SLEW RAM**

Up to five safe load registers can be loaded with parameter RAM address data. The data is transferred to the requested address when the RAM is idle. It is recommended to use this method for dynamic updates during run time. For example, a complete update of one biquad section can occur in one audio frame. This method is not available for writing to the program RAM or control registers.

There are ten safe load registers operating in pairs of five, where five of them store addresses and five of them store data. To safe load a register, move its address into a safe load address register and move its data into the corresponding safe load data register. If it is a parameter RAM, set Bit 4 in Register 0x0200 to 1 to initiate the safe load. If it is a target/slew RAM, set Bit 5 in Register 0x0200 to 1 to initiate the safe load.

The safe load data registers are located from Address 0x2040 to Address 0x2044 and are five-bytes wide.

The safe load address registers are located from Address 0x2045 to Address 0x2049 and are two-bytes wide.

The last five instructions of the program RAM are used for the safe load process; therefore, the program length should be limited to 2555 cycles (2560 - 5). It is guaranteed that the safe load occurs within one LRCLK period (21 μs at f<sub>s</sub> = 48 kHz) of the initiate safe transfer bit being set. Safe load only updates those safe load registers that have been loaded with new data since the last safe load operation. For example, if only two parameters or target RAM locations are updated, it is only necessary to load two of the safe load registers; the other safe load registers are ignored because they contain old data.

**READ/WRITE DATA FORMATS**

The read/write formats of the control port are designed to be byte oriented. This allows easy programming of common micro-controller chips. To fit into a byte-oriented format, 0s are appended to the data fields before the MSB to extend the data-word to eight bits. For example, 28-bit words written to the parameter RAM are appended with four leading 0s to equal 32 bits (4 bytes); 40-bit words written to the program RAM are not appended with 0s because they are already a full five bytes. These zero-padded data fields are appended to a 3-byte field consisting of a 7-bit chip address, a read/write bit, and a 16-bit RAM/register address. The control port knows how many data bytes to expect based on the address given in the first three bytes.

The total number of bytes for a single location write command can vary from five bytes (for a control register write) to eight bytes (for a program RAM write). Burst mode can be used to fill contiguous register or RAM locations. A burst mode write begins by writing the address and data of the first RAM or register location to be written to. Rather than ending the control port transaction (by issuing a stop command in I<sup>2</sup>C mode), as would be done in a single-address write, the next data-word can be written immediately without specifying its address.

# ADAV4601

The ADAV4601 control port auto-increments the address of each write even across the boundaries of the different RAMs and registers.

## TARGET/SLEW RAM

The target/slew RAM is a bank of 64 RAM locations, each of which can be set to autoramp from one value to a desired final value in one of four modes.

When a program is loaded into the program RAM using one or more locations in the slew RAM to access the internal coefficient data, the target/slew RAM is used by the DSP. Typically, these coefficients are used for volume controls or smooth cross-fading effects, but they can also be used to update any value in the parameter RAM. Each of the 64 locations in the slew RAM is linked to a corresponding location in the target RAM. When a new value is written to the target RAM using the control port, the corresponding slew RAM location begins to ramp toward the target. The value is updated once per audio frame (LRCLK period).

The target RAM is 34 bits wide. The lower 28 bits contain the target data in 5.23 format for the linear and exponential (constant decibels and RC) ramp types. For constant time ramping, the lower 28 bits contain 16 bits in 2.14 format and 12 bits to set the current step. The upper six bits are used to determine the type and speed of the ramp envelope in all modes. The format of the data write for linear and exponential formats is shown in Table 12. Table 13 shows the data write format for the constant time ramping.

In normal operation, write data to the target/slew RAM using the safe load registers as described in the Safe Loading to Parameter RAM and Target/Slew RAM section. A mute slew RAM bit is included in the audio core control register to simultaneously set all the slew RAM target values to 0. This is useful for implementing a global multichannel mute. When this bit is de-asserted, all slew RAM values return to their original pre-muted states.

**Table 12. Linear, Constant Decibels, and RC Ramp Data Write**

Byte 0	Byte 1	Bytes[2:4]
000000, Curve_Type[1:0]	Time_Const[3:0], Data[27:24]	Data[23:0]

**Table 13. Constant Time Ramp Data Write**

Byte 0	Byte 1	Bytes[2:4]
000000, Curve_Type[1:0]	Update_Step[0], #_of_Steps[2:0], Data[15:12]	Data[11:0], Reserved[11:0]

There are four types of ramping curves: linear, constant decibels, RC, and constant time.

- The linear ramping curve—The value slews to the target value using a fixed step size.
- The constant decibels ramping curve—The value slews to the target value using the current value to calculate the step size. The resulting curve has a constant rise and decay when measured in decibels.

- The RC ramping curve—The value slews to the target value using the difference between the target and current values to calculate the step size, resulting in a simple RC response.
- The constant time ramping curve—The value slews to the target value in a fixed number of steps in a linear fashion. The control port mute has no effect on this type of ramping curve.

**Table 14. Target/Slew RAM Ramp Type Settings**

Settings	Ramp Type
00	Linear
01	Constant decibels
10	RC
11	Constant time

The following sections detail how the control port writes to the target/slew RAM to control the time constant and ramp type parameters.

### Ramp Types[1:3]—Linear, Constant Decibels, and RC (34-Bit Write)

The target word for the first three ramp types is broken into three parts. The 34-bit command is written with six leading 0s to extend the data write to five bytes. The parts of the target RAM write are

- Ramp type (two bits)
- Time constant (four bits)
- 0000 = fastest
- ...
- 1111 = slowest
- Data (28 bits): 5.23 format

### Ramp Type 4—Constant Time (34-Bit Write)

The target word for the constant time ramp type is written in five parts, with the 34-bit command written with six leading 0s to extend the data write to five bytes. The parts of the constant time target RAM write are

- Ramp type (two bits).
- Update step (one bit). Set to 1 when a new target is loaded to trigger a step value update. The value is automatically reset after the step value is updated.
- Number of steps (three bits). The number of steps needed to slew to the target value is set by these three bits, with the number of steps equal to  $2^{3\text{-bit setting} + 6}$ .
  - 000 = 64
  - 001 = 128
  - 010 = 256
  - 011 = 512
  - 100 = 1024
  - 101 = 2048
  - 110 = 4096
  - 111 = 8196
- Data (16 bits): 2.14 format.
- Reserved (12 bits). When writing to the RAM, set all of these bits to 0.

**Target/Slew RAM Initialization**

On reset, the target/slew RAM initializes to preset values. The target RAM initializes to a linear ramp type with a time constant of 5 and the data set to 1.0. The slew RAM initializes to 1.0. These defaults result in a full-scale (1.0 to 0.0) ramp time of 21.3 ms.

**Linear Update**

A linear update is the addition or subtraction of a constant value, referred to as a step. The following equation describes this step size as

$$Step = \frac{2^{13}}{10^{2 \times (CONST-5)}} \times \frac{1}{20}$$

The result of the equation is normalized to a 5.23 data format. This produces a time constant range from 6.75 ms to 213.4 ms (-60 dB relative to 0 dB full scale). An example of this kind of update is shown in Figure 39 and Figure 40. All slew RAM figure examples, except the half-scale constant time ramp plot (Figure 45), show an increasing or decreasing ramp between -80 dB and 0 dB (full scale). All figures except the constant time plots (Figure 44, Figure 45, and Figure 46) use a time constant of 0x7 (0x0 being the fastest and 0xF being the slowest).

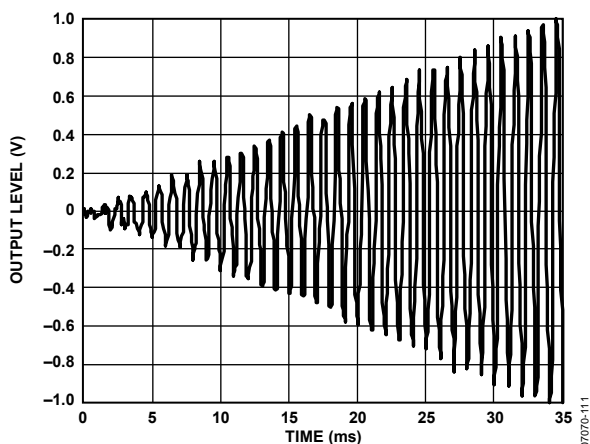

Figure 39. Slew RAM—Linear Update Increasing Ramp

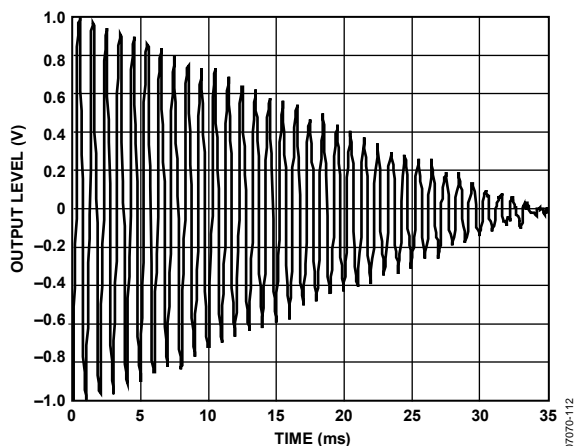

Figure 40. Slew RAM—Linear Update Decreasing Ramp

**Constant Decibels and RC Updates (Exponential)**

An exponential update is accomplished by shifts and additions with a range from 6.1 ms to 1.27 sec (-60 dB relative to 0 dB full scale). When the ramp type is set to 01 (constant decibels), each step size is set to the current value in the slew data. When the ramp type bits are set to 10 (RC), the step size is equal to the difference between the values in the target RAM and the slew RAM (see Figure 41, Figure 42, and Figure 43).

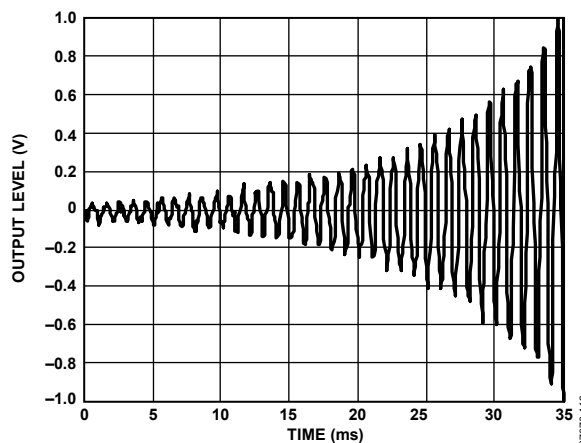

Figure 41. Slew RAM—Constant Decibels Update Increasing Ramp

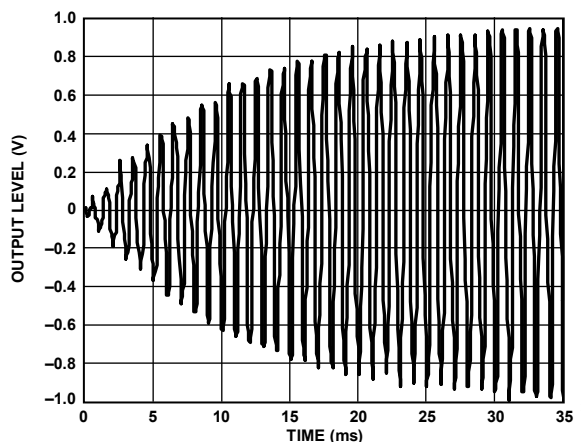

Figure 42. Slew RAM—RC Update Increasing Ramp

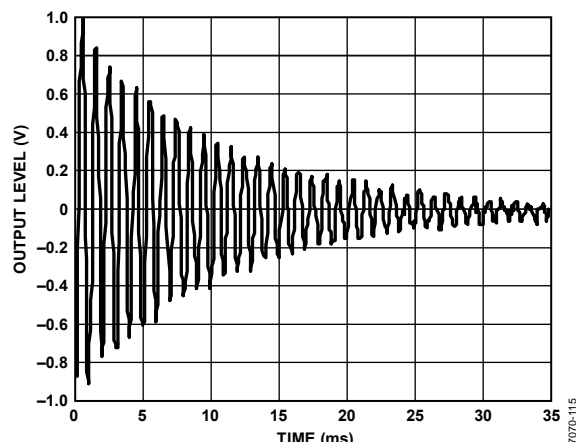

Figure 43. Slew RAM—Constant Decibels and RC Updates Decreasing Ramp, Full Scale

## Constant Time Update

A constant time update is calculated by adding a step value that is determined after each target is loaded. The equation for this step size is

$$\text{Step} = (\text{Target Data} - \text{Slew Data}) / (\text{Number of Steps})$$

Figure 44 shows a plot of the target/slew RAM operating in constant time mode. For this example, 128 steps are used to reach the target value. This type of ramping takes a fixed amount of time for a given number of steps, regardless of the difference in the initial state and the target value. Figure 45 shows a plot of a constant time ramp from  $-80$  dB to  $-6$  dB (half scale) using 128 steps; therefore, the ramp takes the same amount of time as the previous ramp from  $-80$  dB to  $0$  dB. A constant time decreasing ramp plot is shown in Figure 46.

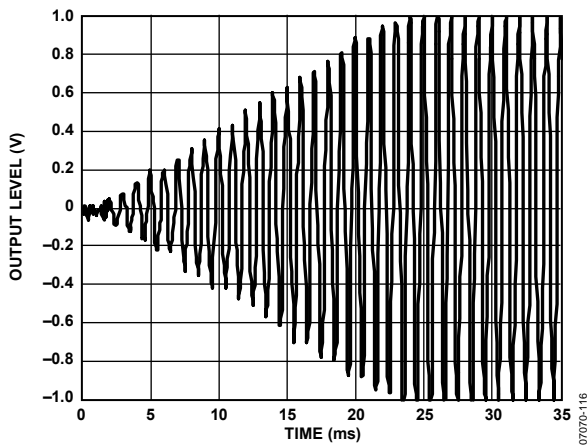

Figure 44. Slew RAM—Constant Time Update Increasing Ramp, Full Scale

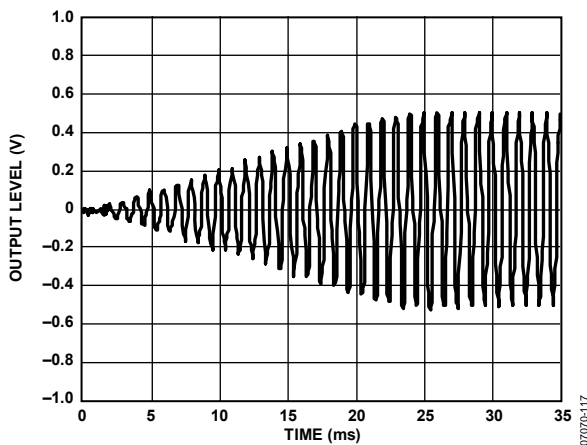

Figure 45. Slew RAM—Constant Time Update Increasing Ramp, Half Scale

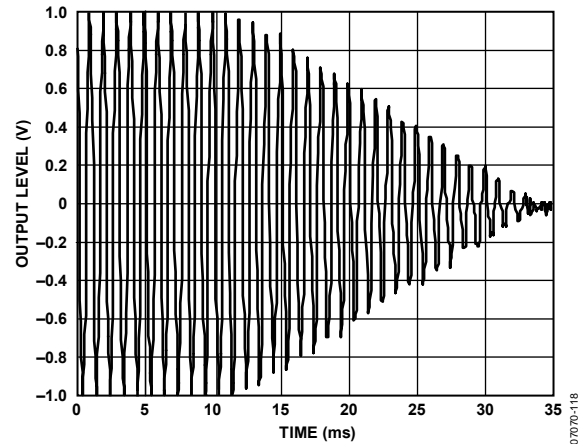

Figure 46. Slew RAM—Constant Time Update Decreasing Ramp, Full Scale

## LAYOUT RECOMMENDATIONS

### Parts Placement

The priority for decoupling is VREF, FILTA, FILTD, PLL\_LF, and finally the supplies. For effective decoupling in all cases, make sure the decoupling capacitor sees the respective ground pin before the ground plane.

The 1 nF and 100 nF bypass capacitors for the PLL loop filter should be placed as close as possible to the ADAV4601. All 10  $\mu$ F and 0.1  $\mu$ F bypass capacitors, which are recommended for every analog, digital, and power/ground pair, should also be placed as close as possible to the ADAV4601 with priority given to the 0.1  $\mu$ F capacitor.

The ADC input voltage-to-current resistors and the ADC current set resistor should be placed as close as possible to the respective pins.

### Crystal Oscillator Circuit

All traces in the crystal oscillator circuit (see Figure 22) should be kept as short as possible to minimize stray capacitance. In addition, avoid long board traces connected to any of these components because such traces may affect crystal startup and operation.

### PWM Outputs

All PWM output differential pairs should be matched in length, that is, PWM1A = PWM1B, PWM2A = PWM2B.

### Grounding

A split ground plane should be used in the layout of the ADAV4601 with the analog and digital grounds connected underneath the ADAV4601 using a single link. This layout is to avoid possible ground loop currents in the analog and digital ground planes. Components in the analog signal path should be placed away from the digital signals. No signal traces should cross the gap between the planes.

# TYPICAL APPLICATION DIAGRAM

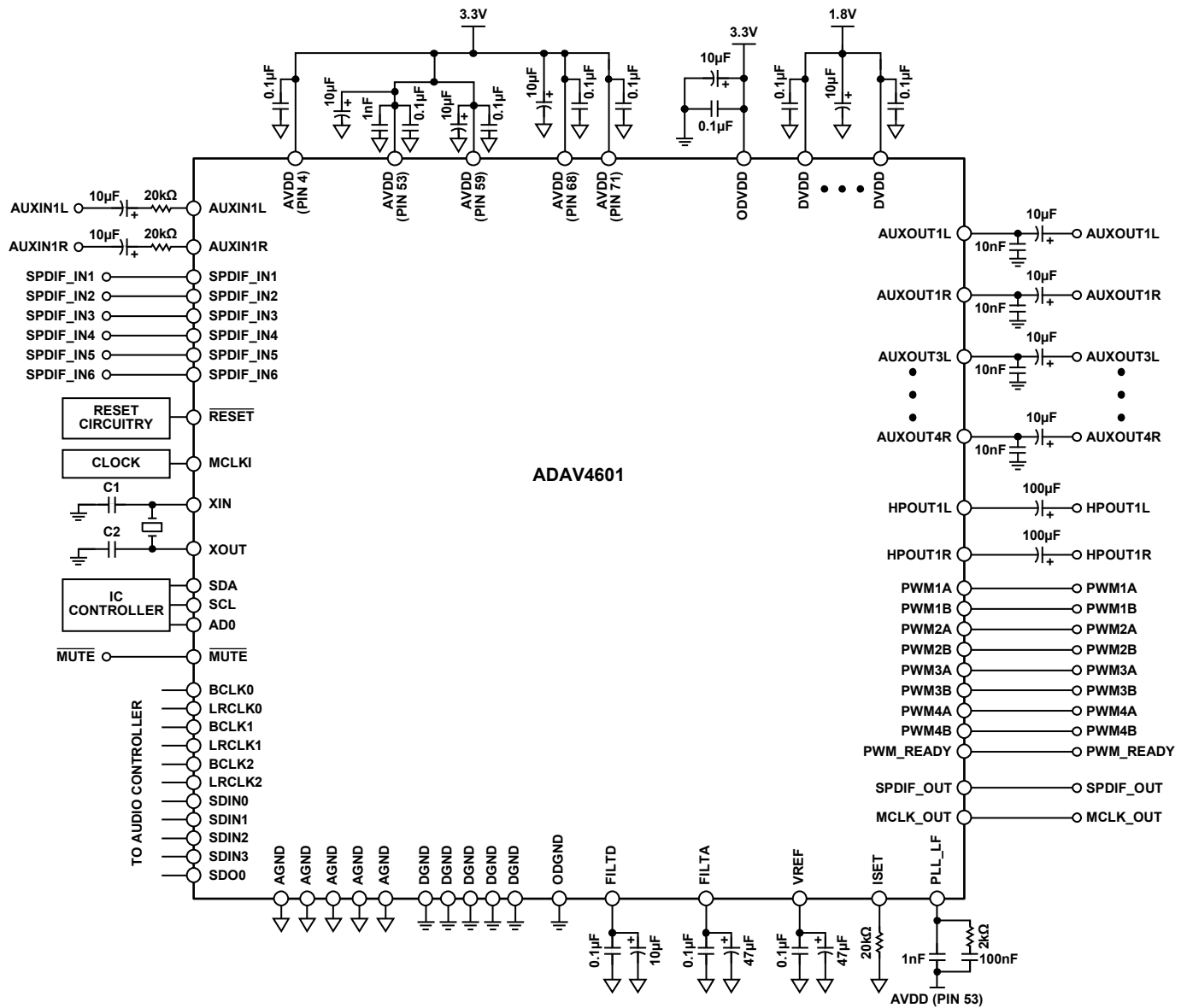

Figure 47. Typical Application Circuit

07070-107

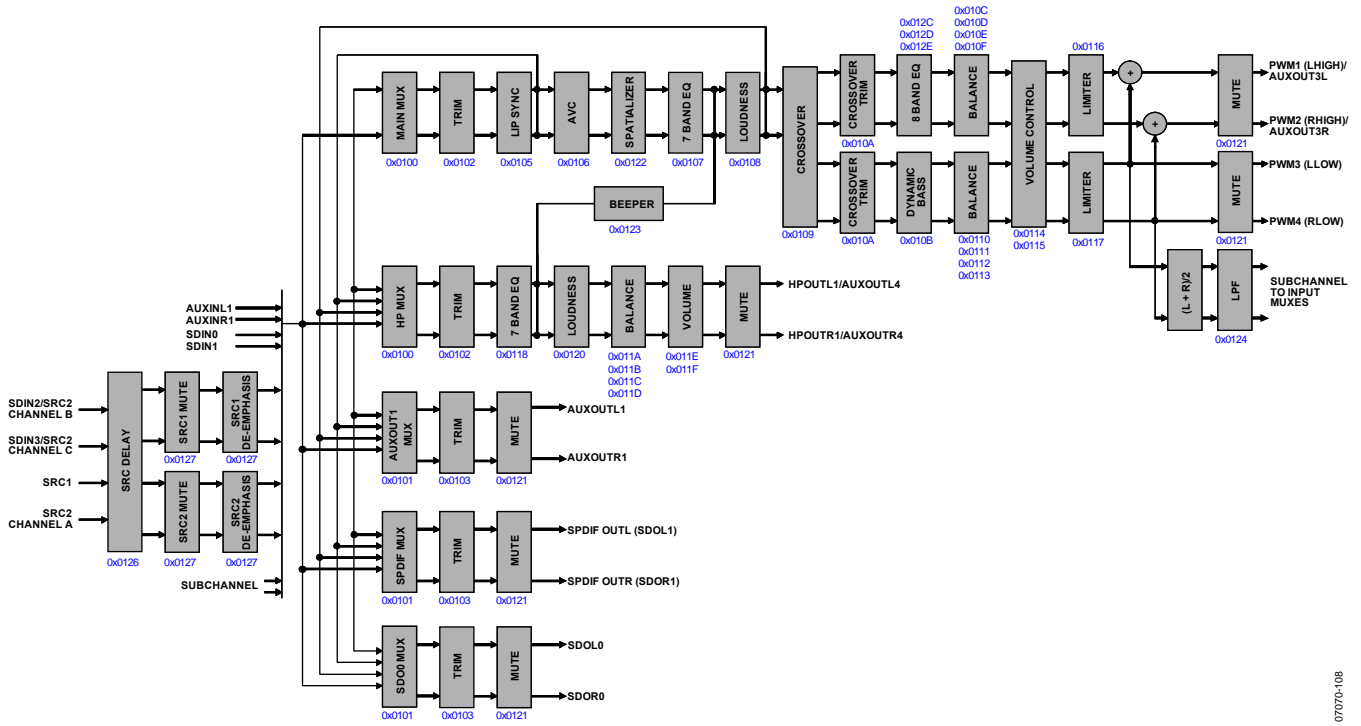

Figure 48. Default Audio Processing Flow

07070-108

## AUDIO FLOW CONTROL REGISTERS

### DETAILED REGISTER DESCRIPTIONS

Address 0x0100 Mux Select 1 Register (Default: 0x0000)

Table 15.

Bit No.	Bit Name	Description	Default
Bits[15:12]	Main source mux	Source for main channel. 0x0 = reserved 0x1 = ADC1 0x2 = reserved 0x3 = SDIN0 0x4 = SDIN1 0x5 = SDIN2/SRC2 Channel B 0x6 = SDIN3/SRC2 Channel C 0x7 = SRC1 0x8 = SRC2 Channel A 0x9 = reserved 0xA = reserved	0000
Bits[11:8]	Reserved	Always write as 0 if writing to this register.	0000
Bits[7:4]	Headphone 1/AUXOUT4 output	Source for the Headphone 1/AUXOUT4 output. 0x0 = reserved 0x1 = ADC1 0x2 = reserved 0x3 = SDIN0 0x4 = SDIN1 0x5 = SDIN2/SRC2 Channel B 0x6 = SDIN3/SRC2 Channel C 0x7 = SRC1 0x8 = SRC2 Channel A 0x9 = reserved 0xA = reserved 0xB = reserved 0xC = delayed main input 0xD = main input after loudness 0xE = subchannel	0000
Bits[3:0]	AUXOUT3 output mux	Source for the AUXOUT3 output. 0x0 = reserved 0x1 = ADC1 0x2 = reserved 0x3 = SDIN0 0x4 = SDIN1 0x5 = SDIN2/SRC2 Channel B 0x6 = SDIN3/SRC2 Channel C 0x7 = SRC1 0x8 = SRC2 Channel A 0x9 = reserved 0xA = reserved 0xB = reserved 0xC = delayed main input 0xD = main input after loudness 0xE = subchannel	0000

# ADAV4601

## Address 0x0101 Mux Select 2 Register (Default: 0x0000)

Table 16.

Bit No.	Bit Name	Description	Default
Bits[15:12]	SDO0 output	Source for the SDO0 output channel. 0x0 = reserved 0x1 = ADC1 0x2 = reserved 0x3 = SDIN0 0x4 = SDIN1 0x5 = SDIN2/SRC2 Channel B 0x6 = SDIN3/SRC2 Channel C 0x7 = SRC1 0x8 = SRC2 Channel A 0x9 = reserved 0xA = reserved 0xB = reserved 0xC = delayed main input 0xD = main input after loudness 0xE = subchannel	0000
Bits[11:8]	SPDIF output	Source for the SPDIF output. 0x0 = reserved 0x1 = ADC1 0x2 = reserved 0x3 = SDIN0 0x4 = SDIN1 0x5 = SDIN2/SRC2 Channel B 0x6 = SDIN3/SRC2 Channel C 0x7 = SRC1 0x8 = SRC2 Channel A 0x9 = reserved 0xA = reserved 0xB = reserved 0xC = delayed main input 0xD = main input after loudness 0xE = subchannel	0000
Bits[7:4]	AUXOUT1 output	Source for the AUXOUT1 output. 0x0 = reserved 0x1 = ADC1 0x2 = reserved 0x3 = SDIN0 0x4 = SDIN1 0x5 = SDIN2/SRC2 Channel B 0x6 = SDIN3/SRC2 Channel C 0x7 = SRC1 0x8 = SRC2 Channel A 0x9 = reserved 0xA = reserved 0xB = reserved 0xC = delayed main input 0xD = main input after loudness 0xE = subchannel	0000
Bits[3:0]	Reserved	Always write as 0 if writing to this register.	0000



**Address 0x0102 Main and Headphone 1/AUXOUT4 Input Trim Register (Default: 0x0E0E)**

Table 17.

Bit No.	Bit Name	Description	Default
Bits[15:14]	Reserved	Always write as 0 if writing to this register.	00
Bits[13:8]	Main input trim	These register bits are used to gain or attenuate the input to the main channel processing path from -14 dB to +14 dB in +1 dB steps. 0x00 = +14 dB 0x01 = +13 dB ... 0x07 = +7 dB ... 0x0E = 0 dB ... 0x15 = -7 dB 0x1B = -13 dB 0x1C = -14 dB	001110
Bits[7:6]	Reserved	Always write as 0 if writing to this register.	00
Bits[5:0]	Headphone 1/AUXOUT4 input trim	These register bits are used to gain or attenuate the input to the Headphone 1/AUXOUT4 channel processing path from -14 dB to +14 dB in +1 dB steps. 0x00 = +14 dB 0x01 = +13 dB ... 0x07 = +7 dB ... 0x0E = 0 dB ... 0x15 = -7 dB ... 0x1B = -13 dB 0x1C = -14 dB	001110

**Address 0x0103 SDO0/AUXOUT3 and SPDIF Input Trim Register (Default: 0x0E0E)**

Table 18.

Bit No.	Bit Name	Description	Default
Bits[15:14]	Reserved	Always write as 0 if writing to this register.	00
Bits[13:8]	SDO0/AUXOUT3 input trim	These register bits are used to gain or attenuate the input to the SDO0 and the AUXOUT3 processing path from -14 dB to +14 dB in +1 dB steps. 0x00 = +14 dB 0x01 = +13 dB ... 0x07 = +7 dB ... 0x0E = 0 dB ... 0x15 = -7 dB 0x1B = -13 dB 0x1C = -14 dB	001110
Bits[7:6]	Reserved	Always write as 0 if writing to this register.	00

# ADAV4601

Bit No.	Bit Name	Description	Default
Bits[5:0]	SPDIF input trim	These register bits are used to gain or attenuate the input to the SPDIF processing path from -14 dB to +14 dB in +1 dB steps. 0x00 = +14 dB 0x01 = +13 dB ... 0x07 = +7 dB ... 0x0E = 0 dB ... 0x15 = -7 dB ... 0x1B = -13 dB ... 0x1C = -14 dB	001110

## Address 0x0104 AUXOUT1 Input Trim Register (Default: 0x0E0E)

Table 19.

Bit No.	Bit Name	Description	Default
Bits[15:14]	Reserved	Always write as 0 if writing to this register.	00
Bits[13:8]	AUXOUT1 input trim	These register bits are used to gain or attenuate the input to the AUXOUT1 channel processing path from -14 dB to +14 dB in +1 dB steps. 0x00 = +14 dB 0x01 = +13 dB ... 0x07 = +7 dB ... 0x0E = 0 dB ... 0x15 = -7 dB 0x1B = -13 dB 0x1C = -14 dB	001110
Bits[7:0]	Reserved	Always write as 0 if writing to this register.	00000000

## Address 0x0105 Main Delay Register (Default: 0x0000)

Table 20.

Bit No.	Bit Name	Description	Default
Bits[15:13]	Reserved	Always write as 0 if writing to this register.	000
Bits[12:0]	Main delay	These register bits are used to specify the lip synchronization delay for the main channel. 0x0000 = 20.83 $\mu$ s (1 sample delay at 48 kHz) 0x0001 = 20.83 $\mu$ s (1 sample delay) 0x0002 = 41.66 $\mu$ s (2 sample delay) ... 0x1C20 = 150 ms (7200 sample delay)	000000000000

**Address 0x0106 Automatic Volume Control (Default: 0x350C)**

Table 21.

Bit No.	Bit Name	Description	Default
Bits[15:12]	AVC maximum gain	Used to control the maximum gain in the range of 0 dB to 15 dB. This is the maximum gain that can be applied to the input signal to reach the desired output level. 0x0 = 15 dB 0x1 = 14 dB 0x2 = 13 dB 0x3 = 12 dB 0x4 = 11 dB 0x5 = 10 dB ... 0xF = 0 dB	0011
Bits[11:8]	AVC decay time	Used to control the decay time in the range of 20 ms to 12 sec. The decay time corresponds to the time required for the output to reach the desired level. 0x0 = 20 ms 0x1 = 100 ms 0x2 = 200 ms 0x3 = 500 ms 0x4 = 1 sec 0x5 = 2 sec 0x6 = 3 sec 0x7 = 4 sec 0x8 = 5 sec 0x9 = 6 sec 0xA = 7 sec 0xB = 8 sec 0xC = 9 sec 0xD = 10 sec 0xE = 11 sec 0xF = 12 sec	0101
Bits[7:4]	AVC maximum attenuation	Used to control the maximum attenuation in the range of -18 dB to -3 dB in +1 dB steps. This is the maximum attenuation that can be applied to the input signal to reach the desired output level. 0x0 = -18 dB 0x1 = -17 dB ... 0xE = -4 dB 0xF = -3 dB	0000
Bits[3:0]	AVC output level	Used to control the required output level of the AVC block in the range of -3 dBFS to -18 dBFS in -1 dB steps. If the input signal is greater than the output level that has been set by these bits, the gain is automatically reduced. 0x0 = -18 dBFS 0x1 = -17 dBFS ... 0xC = -6 dBFS 0xD = -5 dBFS 0xE = -4 dBFS 0xF = -3 dBFS	1100

# ADAV4601

## Address 0x0107 Main Sever Band EQ Control Register (Default: 0x0018)

Table 22.

Bit No.	Bit Name	Description	Default
Bits[15:11]	Reserved	Always write as 0 if writing to this register.	00000
Bits[10:8]	Main EQ band	These register bits control the frequency band of the equalizer. 0x0 = 120 Hz 0x1 = 200 Hz 0x2 = 500 Hz 0x3 = 1200 Hz 0x4 = 3000 Hz 0x5 = 7500 Hz 0x6 = 12,000 Hz	000
Bits[7:6]	Reserved	Always write as 0 if writing to this register.	00
Bits[5:0]	Main EQ gain	These register bits are used to control the required gain of the equalizer. The gain of the equalizer is changed in 0.5 dB steps. 0x00 = +12 dB 0x01 = +11.5 dB ... 0x0A = +7 dB ... 0x18 = 0 dB ... 0x26 = -7 dB ... 0x2F = -11.5 dB 0x30 = -12 dB	011000

## Address 0x0108 Main Channel Loudness Register (Default: 0x0000)

Table 23.

Bit No.	Bit Name	Description	Default
Bits[15:7]	Reserved	Always write as 0 if writing to this register.	000000000
Bits[6:5]	Cutoff frequency	These register bits are used to control the cutoff frequency of the loudness. 00b – 10 Hz 01b – 30 Hz 10b – 50 Hz 11b – 70 Hz	00
Bits[4:0]	Loudness level	These register bits are used to control the required level of loudness. 0x00 = 0 dB 0x01 = +1 dB ... 0x0E = +14 dB 0x0F = +15 dB	00000

**Address 0x0109 Crossover Register (Default: 0x0505)**

Table 24.

Bit No.	Bit Name	Description	Default
Bits[15:14]	Reserved	Always write as 0 if writing to this register.	00
Bits[13:8]	Low crossover frequency	The low crossover frequency is the cutoff frequency of the crossover low-pass filter. This means that only the frequencies under this frequency are sent to the woofer output. The frequency changes in 10 Hz steps. 0x00 = 50 Hz 0x01 = 60 Hz 0x02 = 70 Hz 0x03 = 80 Hz 0x04 = 90 Hz 0x05 = 100 Hz 0x06 = 110 Hz ... 0x2D = 500 Hz 0x2E = 510 Hz	000101
Bits[7:6]	Reserved	Always write as 0 if writing to this register.	00
Bits[5:0]	High crossover frequency	The high crossover frequency is the cutoff frequency of the crossover high-pass filter. This means that only the frequencies above this frequency are sent to the tweeter output. 0x00 = 50 Hz 0x01 = 60 Hz 0x02 = 70 Hz 0x03 = 80 Hz 0x04 = 90 Hz 0x05 = 100 Hz 0x06 = 110 Hz ... 0x3B = 640 Hz 0x3C = 650 Hz	000101

**Address 0x010A Crossover Trim Register (Default: 0x0E0E)**

Table 25.

Bit No.	Bit Name	Description	Default
Bits[15:14]	Reserved	Always write as 0 if writing to this register.	00
Bits[13:8]	Tweeter trim	These register bits are used to gain or attenuate the input to the tweeter outputs from -14 dB to +14 dB in +1 dB steps. 0x00 = +14 dB 0x01 = +13 dB ... 0x07 = +7 dB ... 0x0E = 0 dB ... 0x15 = -7 dB ... 0x1B = -13 dB 0x1C = -14 dB	001110
Bits[7:6]	Reserved	Always write as 0 if writing to this register.	00

# ADAV4601

Bit No.	Bit Name	Description	Default
Bits[5:0]	Woofer trim	These register bits are used to gain or attenuate the input to the woofer outputs from -14 dB to +14 dB in +1 dB steps. 0x00 = +14 dB 0x01 = +13 dB ... 0x07 = +7 dB ... 0x0E = 0 dB ... 0x15 = -7 dB ... 0x1B = -13 dB 0x1C = -14 dB	001110

## Address 0x010B ADI Bass Control Register (Default: 0x0062)

Table 26.

Bit No.	Bit Name	Description	Default
Bits[15:9]	Reserved	Always write as 0 if writing to this register.	0000000
Bits[8:4]	Boost value	The boost ranges from 0 dB to 31 dB, and it controls the maximum dynamic gain applied to the algorithm. 0x00 = 0 dB 0x01 = 1 dB 0x02 = 2 dB 0x03 = 3 dB 0x04 = 4 dB 0x05 = 5 dB 0x06 = 6 dB 0x07 = 7 dB ... 0x1E = 30 dB 0x1F = 31 dB	00110
Bits[3:0]	Boost frequency	The boost frequency ranges from 20 Hz to 320 Hz, and it designates the center frequency for the boosting filter. The frequency is increased in 20 Hz steps. 0x0 = 20 Hz 0x1 = 40 Hz 0x2 = 60 Hz 0x3 = 80 Hz ... 0xE = 300 Hz 0xF = 320 Hz	0010

**Address 0x010C and Address 0x010D Tweeter Left Balance Control Registers (Default: 0x0080, 0x0000)**

These two registers (0x010C and 0x010D) control the balance for the left tweeter output.

The balance control words are 28-bit words in twos complement and a 5.23 format. This means there are five bits to the left of the decimal point of which the most significant bit is the sign bit.

To simplify updating the tweeter left balance control, the I<sup>2</sup>C address pointer auto-increments when writing and reading. This means that the balance control register can be updated in a single I<sup>2</sup>C block write. Therefore, it is recommended that the tweeter left balance control be updated using the following I<sup>2</sup>C write format:

<dev addr><010C><32-bit data transfer>

Note that the tweeter left balance control is a 32-bit parameter; therefore, both Register 0x010C and Register 0x010D must be written to. Writing anything less than the 32 bits to these registers does not update the parameter.

**Table 27.**

Bit No.	Bit Name	Description	Default
Bits[15:12]	Reserved	Always write as 0 if writing to this register.	0000
Bits[11:0]	Tweeter left balance control register[27:0]	0x010C Bits[11:0] = tweeter left balance control register[27:16]	000010000000
Bits[15:0]	Tweeter left balance control register[27:0]	0x010D Bits[15:0] = tweeter left balance control register[15:0]	0000000000000000

**Address 0x010E and Address 0x010F Tweeter Right Balance Control Registers (Default: 0x0080, 0x0000)**

These two registers (0x010E and 0x010F) control the balance for the right tweeter output.

The balance control words are 28-bit words in twos complement and a 5.23 format. This means there are five bits to the left of the decimal point of which the most significant bit is the sign bit.

**Table 28.**

Bit No.	Bit Name	Description	Default
Bits[15:12]	Reserved	Always write as 0 if writing to this register.	0000
Bits[11:0]	Tweeter right balance control register[27:0]	0x010E Bits[11:0] = tweeter right balance control register[27:16]	000010000000
Bits[15:0]	Tweeter right balance control register[27:0]	0x010F Bits[15:0] = tweeter right balance control register[15:0]	0000000000000000

**Address 0x0110 and Address 0x0111 Woofer Left Balance Control Registers (Default: 0x0080, 0x0000)**

These two registers control the balance for the left woofer output.

The balance control words are 28-bit words in twos complement and a 5.23 format. This means there are five bits to the left of the decimal point of which the most significant bit is the sign bit.

**Table 29.**

Bit No.	Bit Name	Description	Default
Bits[15:12]	Reserved	Always write as 0 if writing to this register.	0000
Bits[11:0]	Woofer left balance control register[27:0]	0x0110 Bits[11:0] = woofer left balance control register[27:16]	000010000000
Bits[15:0]	Woofer left balance control register[27:0]	0x0111 Bits[15:0] = woofer left balance control register[15:0]	0000000000000000

# ADAV4601

## Address 0x0112 and Address 0x0113 Woofer Right Balance Control Registers (Default: 0x0080, 0x0000)

These two registers control the balance for the right tweeter output.

The balance control words are 28-bit words in twos complement and a 5.23 format. This means there are five bits to the left of the decimal point of which the most significant bit is the sign bit.

Table 30.

Bit No.	Bit Name	Description	Default
Bits[15:12]	Reserved	Always write as 0 if writing to this register.	0000
Bits[11:0]	Woofer right balance control register[27:0]	0x0112 Bits[11:0] = woofer right balance control register[27:16]	000010000000
Bits[15:0]	Woofer right balance control register[27:0]	0x0113 Bits[15:0] = woofer right balance control register[15:0]	0000000000000000

## Address 0x0114 and Address 0x0115 Main Volume Control Registers (Default: 0x0080, 0x0000)

These two registers control the volume for the main channel output.

The volume control words are 28-bit words in twos complement and a 5.23 format. This means there are five bits to the left of the decimal point of which the most significant bit is the sign bit.

Table 31.

Bit No.	Bit Name	Description	Default
Bits[15:12]	Reserved	Always write as 0 if writing to this register.	0000
Bits[11:0]	Woofer right balance control register[27:0]	0x0114 Bits[11:0] = main volume Bits[27:16]	000010000000
Bits[15:0]	Woofer right balance control register[27:0]	0x0115 Bits[15:0] = main volume Bits[15:0]	0000000000000000

## Address 0x0116 Tweeter Peak Limiter Control Register (Default: 0x0F00)

This register controls the peak limiter for the main output tweeter.

Table 32.

Bit No.	Bit Name	Description	Default
Bits[15:13]	Reserved	Always write as 0 if writing to this register.	000
Bits[12:8]	Post gain	These register bits control the post gain in the range of +15 dB to –15 dB in +1 dB steps. 0x00 = +15 dB 0x01 = +14 dB ... 0x08 = +7 dB ... 0x0F = +0 dB ... 0x16 = –7 dB ... 0x1D = –14 dB 0x1E = –15 dB	01111
Bits[7:5]	Hold time	These register bits control the hold time for the limiter, which is the time in ms that the limiter holds the attenuated level after the current input to the limiter function falls below the limiter threshold. 0x0 = 0 ms 0x1 = 10 ms 0x2 = 20 ms 0x3 = 30 ms 0x4 = 40 ms 0x5 = 50 ms 0x6 = 60 ms 0x7 = 70 ms	000



Bit No.	Bit Name	Description	Default
Bits[4:0]	Decay time	<p>These register bits control the decay time for the limiter in the range of 10 dB/s to 320 dB/s in 10 dB/s steps.</p> <p>0x00 = 10 dB/s (~870 ms)                      0x01 = 20 dB/s (~435 ms)                      0x02 = 30 dB/s (~289 ms)                      0x03 = 40 dB/s (~217 ms)                      0x04 = 50 dB/s (~173 ms)                      0x05 = 60 dB/s (~144 ms)                      0x06 = 70 dB/s (~124 ms)                      0x07 = 80 dB/s (~108 ms)                      0x08 = 90 dB/s (~96 ms)                      0x09 = 100 dB/s (~86 ms)                      0x0A = 110 dB/s (~78 ms)                      0x0B = 120 dB/s (~72 ms)                      0x0C = 130 dB/s (~66 ms)                      0x0D = 140 dB/s (~62 ms)                      0x0E = 150 dB/s (~57 ms)                      0x0F = 160 dB/s (~54 ms)                      0x10 = 170 dB/s (~51 ms)                      0x11 = 180 dB/s (~48 ms)                      0x12 = 190 dB/s (~45 ms)                      0x13 = 200 dB/s (~43 ms)                      0x14 = 210 dB/s (~41 ms)                      0x15 = 220 dB/s (~39 ms)                      0x16 = 230 dB/s (~37 ms)                      0x17 = 240 dB/s (~36 ms)                      0x18 = 250 dB/s (~34 ms)                      0x19 = 260 dB/s (~33 ms)                      0x1A = 270 dB/s (~32 ms)                      0x1B = 280 dB/s (~31 ms)                      0x1C = 290 dB/s (~29 ms)                      0x1D = 300 dB/s (~28 ms)                      0x1E = 310 dB/s (~28 ms)                      0x1F = 320 dB/s (~27 ms)</p>	00000

**Address 0x0117 Woofer Peak Limiter Control Register (Default: 0x0F00)**

Table 33.

Bit No.	Bit Name	Description	Default
Bits[15:13]	Reserved	Always write as 0 if writing to this register.	000
Bits[12:8]	Post gain	<p>These register bits control the post gain in the range of +15 dB to -15 dB in +1 dB steps.</p> <p>0x00 = +15 dB                      0x01 = +14 dB                      ...                      0x08 = +7 dB                      ...                      0x0F = 0 dB                      ...                      0x16 = -7 dB                      ...                      0x1D = -14 dB                      0x1E = -15 dB</p>	01111

# ADAV4601

Bit No.	Bit Name	Description	Default
Bits[7:5]	Hold time	<p>These register bits control the hold time for the limiter, which is the time in ms that the limiter holds the attenuated level after the current input to the limiter function falls below the limiter threshold.</p> <p>0x0 = 0 ms            0x1 = 10 ms            0x2 = 20 ms            0x3 = 30 ms            0x4 = 40 ms            0x5 = 50 ms            0x6 = 60 ms            0x7 = 70 ms</p>	000
Bits[4:0]	Decay time	<p>These register bits control the decay time for the limiter in the range of 10 dB/s to 320 dB/s in 10 dB/s steps.</p> <p>0x00 = 10 dB/s (~870 ms)            0x01 = 20 dB/s (~435 ms)            0x02 = 30 dB/s (~289 ms)            0x03 = 40 dB/s (~217 ms)            0x04 = 50 dB/s (~173 ms)            0x05 = 60 dB/s (~144 ms)            0x06 = 70 dB/s (~124 ms)            0x07 = 80 dB/s (~108 ms)            0x08 = 90 dB/s (~96 ms)            0x09 = 100 dB/s (~86 ms)            0x0A = 110 dB/s (~78 ms)            0x0B = 120 dB/s (~72 ms)            0x0C = 130 dB/s (~66 ms)            0x0D = 140 dB/s (~62 ms)            0x0E = 150 dB/s (~57 ms)            0x0F = 160 dB/s (~54 ms)            0x10 = 170 dB/s (~51 ms)            0x11 = 180 dB/s (~48 ms)            0x12 = 190 dB/s (~45 ms)            0x13 = 200 dB/s (~43 ms)            0x14 = 210 dB/s (~41 ms)            0x15 = 220 dB/s (~39 ms)            0x16 = 230 dB/s (~37 ms)            0x17 = 240 dB/s (~36 ms)            0x18 = 250 dB/s (~34 ms)            0x19 = 260 dB/s (~33 ms)            0x1A = 270 dB/s (~32 ms)            0x1B = 280 dB/s (~31 ms)            0x1C = 290 dB/s (~29 ms)            0x1D = 300 dB/s (~28 ms)            0x1E = 310 dB/s (~28 ms)            0x1F = 320 dB/s (~27 ms)</p>	0000

**Address 0x0118 Headphone 1/AUXOUT4 Seven Band EQ Control Register (Default: 0x0018)**

Table 34.

Bit No.	Bit Name	Description	Default
Bits[15:11]	Reserved	Always write as 0 if writing to this register.	00000
Bits[10:8]	Headphone 1/ AUXOUT4 EQ band	These register bits control the frequency band of the equalizer.  0x0 = 120 Hz 0x1 = 200 Hz 0x2 = 500 Hz 0x3 = 1200 Hz 0x4 = 3000 Hz 0x5 = 7500 Hz 0x6 = 12000 Hz	000
Bits[7:6]	Reserved	Always write as 0 if writing to this register.	00
Bits[5:0]	Headphone 1/ AUXOUT4 EQ gain	These register bits are used to control the required gain of the equalizer. The gain of the equalizer is changed in 0.5 dB steps.  0x00 = +12 dB 0x01 = +11.5 dB ... 0x0A = +7 dB ... 0x18 = 0 dB ... 0x26 = -7 dB ... 0x2F = -11.5 dB 0x30 = -12 dB	001110

**Address 0x011A and Address 0x011B Headphone 1/AUXOUT4 Left Balance Control Registers (Default: 0x0080, 0x0000)**

These two registers control the balance for the Left Headphone 1 and AUXOUT 4 output.

The balance control words are 28-bit words in twos complement and a 5.23 format. This means there are five bits to the left of the decimal point of which the most significant bit is the sign bit.

Table 35.

Bit No.	Bit Name	Description	Default
Bits[15:12]	Reserved	Always write as 0 if writing to this register.	0000
Bits[11:0]	Woofer left balance control register[27:0]	0x011A Bits[11:0] = Headphone 1/AUXOUT 4 left balance control register[27:16]	000010000000
Bits[15:0]	Woofer left balance control register[27:0]	0x011B Bits[15:0] = Headphone 1/AUXOUT 4 left balance control register[15:0]	0000000000000000

**Address 0x011C and Address 0x011D Headphone 1/AUXOUT4 Right Balance Control Registers (Default: 0x0080, 0x0000)**

These two registers control the balance for the Right Headphone 1 and AUXOUT 4 output.

The balance control words are 28-bit words in twos complement and a 5.23 format. This means there are five bits to the left of the decimal point of which the most significant bit is the sign bit.

Table 36.

Bit No.	Bit Name	Description	Default
Bits[15:12]	Reserved	Always write as 0 if writing to this register.	0000
Bits[11:0]	Woofer left balance control register[27:0]	0x011C Bits[11:0] = Headphone 1/AUXOUT 4 right balance control register[27:16]	000010000000
Bits[15:0]	Woofer left balance control register[27:0]	0x011D Bits[15:0] = Headphone 1/AUXOUT 4 right balance control register[15:0]	0000000000000000

# ADAV4601

## Address 0x011E and Address 0x011F Headphone 1/AUXOUT4 Volume Control Registers (Default: 0x0080, 0x0000)

These two registers control the volume for the headphone and AUXOUT4 outputs.

The volume control words are 28-bit words in twos complement and a 5.23 format. This means there are five bits to the left of the decimal point of which the most significant bit is the sign bit.

Table 37.

Bit No.	Bit Name	Description	Default
Bits[15:12]	Reserved	Always write as 0 if writing to this register.	0000
Bits[11:0]	Headphone 1 volume control[27:0]	0x011E Bits[11:0] = Headphone 1/AUXOUT 4 volume Bits[27:16]	000010000000
Bits[15:0]	Headphone 1 volume control[27:0]	0x011F Bits[15:0] = Headphone 1/AUXOUT 4 volume Bits[15:0]	0000000000000000

## Address 0x0120 Headphone 1/AUXOUT4 Channel Loudness Register (Default: 0x0000)

Table 38.

Bit No.	Bit Name	Description	Default
Bits[15:7]	Reserved	Always write as 0 if writing to this register.	000000000
Bits[6:5]	Cutoff frequency	These register bits are used to control the cutoff frequency of the loudness. 00b = 10 Hz 01b = 30 Hz 10b = 50 Hz 11b = 70 Hz	00
Bits[4:0]	Loudness level	These register bits are used to control the required level of loudness. It can be changed in 1 dB steps. 0x00 = 0 dB 0x01 = 1 dB ... 0x0E = 14 dB 0x0F = 15 dB	00000

## Address 0x0121 Mute Control Register (Default: 0x0000)

Table 39.

Bit No.	Bit Name	Description	Default
Bits[15:8]	Reserved	Always write as 0 if writing to this register.	00000000
Bit[7]	Mute tweeter output	Mutes the tweeter output. 0b = mutes 1b = unmutes	0
Bit[6]	Mute woofer output	Mutes the woofer output. 0b = mutes 1b = unmutes	0
Bit[5]	Mute AUXOUT3 output	Mutes the AUXOUT3 output. 0b = mutes 1b = unmutes	0
Bit[4]	Mute HP1/AUXOUT4 output	Mutes the Headphone 1 and AUXOUT4 output. 0b = mutes 1b = unmutes	0
Bit[3]	Mute SDO0 output	Mutes the SDO0 output. 0b = mutes 1b = unmutes	0
Bit[2]	Mute SPDIF output	Mutes the SPDIF output. 0b = mutes 1b = unmutes	0

Bit No.	Bit Name	Description	Default
Bit[1]	Mute AUXOUT1 output	Mutes the AUXOUT1 output. 0b = mutes 1b = unmutes	0
Bit[0]	Reserved	Always write as 0 if writing to this register.	0

**Address 0x0122 Audio Flow Control Register (Default: 0x8001)**

**Table 40.**

Bit No.	Bit Name	Description	Default
Bit[15]	Reserved	Always write a 1 if writing to this register.	1
Bit[14]	Enable AVC	When set to 1, it enables the AVC function. 0b = disabled 1b = enabled	0
Bit[13]	Enable main delay	When set to 1, it enables the lip synchronization delay. 0b = disabled 1b = enabled	0
Bit[12]	Enable main EQ	When set to 1, it enables the seven band equalizer. 0b = disabled 1b = enabled	0
Bit[11]	Enable ADI bass	When set to 1, it enables the ADI bass. 0b = disabled 1b = enabled	0
Bit[10]	Enable main loudness	When set to 1, it enables the loudness. 0b = disabled 1b = enabled	0
Bit[9]	Enable main beeper	When set to 1, it leaves only the beeper on the main channel. By default, this register bit is set to 0, which means the main channel input is added to the beeper. 0b = beeper and channel 1b = beeper only	0
Bit[8]	Enable main limiter	When set to 1, it enables the tweeter and woofer peak limiters. 0b = disabled 1b = enabled	0
Bit[7]	Enable speaker EQ	When set to 1, it enables the eight band speaker equalizer for the tweeter output. 0b = disabled 1b = enabled	0
Bit[6]	Enable crossover bypass	When set to 1, it enables the crossover low-pass and high-pass filters for the main channel. 0b = disabled 1b = enabled	0
Bit[5]	Tweeter output control	When set to 1, the tweeter and woofer outputs are added together and output on the tweeter output. 0b = tweeter only 1b = tweeter and woofer	0
Bit[4]	Enable subchannel LPF	Used to control the LPF on the subchannel. 0b = enabled 1b = disabled	0
Bit[3]	Enable HP1 EQ	When set to 1, it enables the seven band equalizer for the Headphone 1 channel. 0b = disabled 1b = enabled	0

# ADAV4601

Bit No.	Bit Name	Description	Default
Bit[2]	Enable HP1 loudness	When set to 1, it enables the loudness for the Headphone 1 channel. 0b = disabled 1b = enabled	0
Bit[1]	Enable HP1 beeper	When set to 1, it leaves only the beeper on the Headphone 1 channel. By default, this bit is 0, which means the Headphone 1 channel input is added to the beeper. 0b = beeper and channel 1b = beeper only	0
Bit[0]	Enable spatializer	When set to 1, it enables the ADI spatializer. 0b = disabled 1b = enabled	1

## Address 0x0123 Main Beeper Control Register (Default: 0x0005)

This register controls the main beeper block.

Table 41.

Bit No.	Bit Name	Description	Default
Bits[15:12]	Reserved	Always write as 0 if writing to this register.	0000
Bits[11:8]	Volume gain	These register bits control the volume of the beeper in the range of -38 dB to -10 dB in +2 dB steps. 0x0 = off 0x1 = -38 dB 0x2 = -36 dB ... 0xE = -12 dB 0xF = -10 dB	0000
Bits[7:6]	Reserved	Always write as 0 if writing to this register.	00
Bits[5:0]	Frequency	These register bits control the frequency of the beeper in the range of 0 Hz (beeper off) to 11812.5 Hz in 187.5 Hz steps. 0x00 = 0 Hz 0x01 = 187.5 Hz 0x02 = 375 Hz 0x03 = 562.5 Hz 0x04 = 750 Hz 0x05 = 937.5 Hz 0x06 = 1125 Hz ... 0x2E = 8625 Hz 0x2F = 8812.5 Hz	000101

## Address 0x0124 Low-Pass Filter (Subchannel) Register (Default: 0x0003)

This register is used to control the low-pass filter cutoff frequency for the subwoofer channel.

Table 42.

Bit No.	Bit Name	Description	Default
Bits[15:4]	Reserved	Always write as 0 if writing to this register.	000000000000
Bits[3:0]	LPF sub cutoff	These register bits control the cutoff frequency of the low-pass filter of the subwoofer channel. The range of values is 60 Hz to 340 Hz in 20 Hz steps. 0x0 = off 0x1 = 60 Hz 0x2 = 80 Hz 0x3 = 100 Hz 0x4 = 120 Hz ... 0xE = 320 Hz 0xF = 340 Hz	0011

**Address 0x0126 SRC Delay Register (Default: 0x0000)**

This register is used to set the delay for the SRC channel.

**Table 43.**

Bit No.	Bit Name	Description	Default
Bits[15:12]	Reserved	Always write as 0 if writing to this register.	0000
Bits[11:0]	SRC delay	The range of values is 20.83 $\mu$ s to 42 ms in 20.83 $\mu$ s (1 sample delay) steps. 0x000 = 20.83 $\mu$ s (1 sample delay) 0x001 = 41.66 $\mu$ s (2 sample delay) ... 0x7E1 = 42 ms (2017 sample delay)	000000000000

**Address 0x0127 SRC Control Register (Default: 0x0030)**

This register is used to enable the DSP mute circuit for SRC1 and SRC2. If SRC is enabled and detects an error, it will mute the output of the SRC. It also bypasses the de-emphasis filters of the SRC.

**Table 44.**

Bit No.	Bit Name	Description	Default
Bits[15:6]	Reserved	Always write as 0 if writing to this register.	0000000000
Bit[5]	SRC1 de-emphasis filter bypass	This bypasses the SRC1 de-emphasis filter. 0b = bypass 1b = enabled	0
Bit[4]	SRC2 de-emphasis filter bypass	This bypasses the SRC2 de-emphasis filter. 0b = bypass 1b = enabled	0
Bit[3]	SRC1 DSP mute circuit bypass	If an error is detected, it mutes the output of SRC1. 0b = enabled 1b = disabled	0
Bit[2]	SRC2 Channel A DSP mute circuit bypass	If an error is detected, it mutes the output of SRC2. 0b = enabled 1b = disabled	0
Bit[1]	SRC2 Channel B DSP mute circuit bypass	If an error is detected, it mutes the output of SRC2. 0b = enabled 1b = disabled	0
Bit[0]	SRC2 Channel C DSP mute circuit bypass	If an error is detected, it mutes the output of SRC2. 0b = enabled 1b = disabled	0

## MAIN CONTROL REGISTERS

### DETAILED REGISTER DESCRIPTIONS

*Address 0x0000 Initialization Control Register (Default: 0x0080)*

Table 45.

Bit No.	Bit Name	Description	Default
Bits[15:13]	Reserved	Always write as 0 if writing to this register.	000
Bit[12]	Slew mute	When set to 1, all slew parameters ramp to zero. It is recommended to set this bit to 1 prior to downloading a new program to reduce any risk of pops or clicks on the output. 0b = unmuted 1b = muted	0
Bit[11]	Reserved	Always write as 0 if writing to this register.	0
Bits[10:9]	MCLKI frequency select	Used to select the MCLKI pin frequency. 00b = $512 \times$ frequency sample (FS) (24.576 MHz) 01b = $256 \times$ FS (12.288 MHz) 10b = $128 \times$ FS (6.144 MHz) 11b = $64 \times$ FS (3.072 MHz)	00
Bits[8:7]	SRC2 Channel A input select	Used to select the source for SRC2 Channel A. 00b = SDIN0 01b = SDIN1 10b = SDIN2 11b = SDIN3	01
Bits[6:5]	SRC1 input select	Used to select the source for SRC1. 00b = SDIN0 01b = SDIN1 10b = SDIN2 11b = SDIN3	00
Bit[4]	SRC2 Channel A enable	Used to enable SRC2 Channel A. 0b = disabled 1b = enabled	0
Bit[3]	SRC1 enable	Used to enable SRC1 Channel A. 0b = disabled 1b = enabled	0
Bit[2]	GSB enable	When set to 1, the ADAV4601 enters standby mode. 0b = disable standby or not in standby 1b = enable standby or not in standby	0
Bit[1]	Audio processor enable	Set to 1 to enable the audio processor. 0b = disabled 1b = enabled	0
Bit[0]	GPU	Globally powers up all parts of the device. If read back, it indicates the status of the global power-up. 0b = use power management register 1b = global power-up	0



**Address 0x0004 Serial Port Control 1 Register (Default: 0x0000)**

Table 46.

Bit No.	Bit Name	Description	Default
Bits[15:13]	Reserved	Always write as 0 if writing to this register.	000
Bits[12:11]	SRC2 serial mode	Used to select the format of the data for SRC2. 00b = I <sup>2</sup> S 01b = left-justified 10b = right-justified 11b = not applicable	00
Bits[10:9]	SRC2 word width	Used to specify the word width of the data. 00b = 24 bits 01b = 20 bits 10b = 16 bits 11b = not applicable	00
Bits[8:7]	SRC1 serial mode	Used to select the format of the data for SRC1. 00b = I <sup>2</sup> S 01b = left-justified 10b = right-justified 11b = not applicable	00
Bits[6:5]	SRC1 word width	Used to specify the word width of the data. 00b = 24 bits 01b = 20 bits 10b = 16 bits 11b = not applicable	00
Bit[4]	Sync master slave	Used to set master or slave mode for the synchronous input. In slave mode, LRCLK1 and BCLK1 are provided by another source. In master mode, the ADAV4601 provides LRCLK1 and BCLK1. 0b = slave 1b = master	0
Bits[3:2]	Sync serial mode	Used to select the format of the data for the inputs used by the synchronous serial input block. 00b = I <sup>2</sup> S 01b = left-justified 10b = right-justified 11b = not applicable	00
Bits[1:0]	Sync word width	Used to specify the word width of the data for the synchronous digital inputs. 00b = 24 bits 01b = 20 bits 10b = 16 bits 11b = not applicable	00

**Address 0x0005 Analog Power Management 1 Register (Default: 0x8000)**

Table 47.

Bit No.	Bit Name	Description	Default
Bit[15]	DAC standby disable	Set to 1 after reset, which means all DACs are in normal mode but are still powered down. 0b = DACs in low power mode 1b = DACs in normal mode	1
Bit[14]	Reserved	Always write as 0 if writing to this register.	0
Bit[13]	REF BUF	Provides the voltage reference for the analog core. 1b = block powered up 0b = block powered down	0
Bit[12]	Reserved	Always write as 0 if writing to this register.	0
Bit[11]	Reserved	Always write as 0 if writing to this register.	0

# ADAV4601

Bit No.	Bit Name	Description	Default
Bit[10]	ADC1 right	Powers on the ADC1 right channel. 1b = block powered up 0b = block powered down	0
Bit[9]	ADC1 left	Powers on the ADC1 left channel. 1b = block powered up 0b = block powered down	0
Bit[8:7]	Reserved	Always write as 0 if writing to this register.	00
Bit[6]	AUXDAC3 right	Powers on the AUXDAC3 right channel. 1b = block powered up 0b = block powered down	0
Bit[5]	AUXDAC3 left	Powers on the AUXDAC3 left channel. 1b = block powered up 0b = block powered down	0
Bit[4]	Reserved	Always write as 0 if writing to this register.	0
Bit[3]	Reserved	Always write as 0 if writing to this register.	0
Bit[2]	Reserved	Always write as 0 if writing to this register.	0
Bit[1]	AUXDAC1 right	Powers on the AUXDAC1 right channel. 1b = block powered up 0b = block powered down	0
Bit[0]	AUXDAC1 left	Powers on the AUXDAC1 left channel. 1b = block powered up 0b = block powered down	0

## Address 0x0006 Analog Power Management 2 Register (Default: 0x0000)

Table 48.

Bit No.	Bit Name	Description	Default
Bits[15:10]	Reserved	Always write as 0 if writing to this register.	000000
Bit[9]	PLL	Powers on the PLL. 1b = block powered up 0b = block powered down	0
Bits[8:6]	Reserved	Always write as 0 if writing to this register.	000
Bit[5]	Reserved	Always write as 0 if writing to this register.	0
Bit[4]	Reserved	Always write as 0 if writing to this register.	0
Bit[3]	HP1 DAC right	Powers on the HP1 DAC right channel. 1b = block powered up 0b = block powered down	0
Bit[2]	HP1 DAC left	Powers on the HP1 DAC left channel. 1b = block powered up 0b = block powered down	0
Bit[1]	HP1 AMP right	Powers on the HP1 AMP right channel. 1b = block powered up 0b = block powered down	0
Bit[0]	HP1 AMP left	Powers on the HP1 AMP left channel. 1b = block powered up 0b = block powered down	0

**Address 0x0007 Digital Power Management Register (Default: 0x0000)**

Table 49.

Bit No.	Bit Name	Description	Default
Bits[15:8]	Reserved	Always write as 0 if writing to this register.	00000000
Bit[7]	PWM	Powers on the PWM channels. 1b = block powered up 0b = block powered down	0
Bit[6]	S/PDIF TX	Powers on the S/PDIF transmitter. 1b = block powered up 0b = block powered down	0
Bit[5]	Reserved	Always write as 0 if writing to this register.	0
Bit[4]	SRC2	Powers on SRC2. 1b = block powered up 0b = block powered down	0
Bit[3]	SRC1	Powers on SRC1. 1b = block powered up 0b = block powered down	0
Bit[2]	Reserved	Always write as 0 if writing to this register.	0
Bit[1]	ADC/DAC engine	Powers on the ADC/DAC engine. 1b = block powered up 0b = block powered down	0
Bit[0]	Audio processor	Powers on the audio processor core. 1b = block powered up 0b = block powered down	0

**Address 0x0009 SPDIF Transmitter Control Register (Default: 0x0000)**

Table 50.

Bit No.	Bit Name	Description	Default
Bits[15:8]	Reserved	Always write as 0 if writing to this register.	00000000
Bits[14:12]	SPDIF output select	Selects the source for the SPDIF output. 000b = output internally generated SPDIF 001b = output SPDIF_IN2 010b = output SPDIF_IN1 011b = output SPDIF_IN0 100b = output SPDIF_IN3 101b = output SPDIF_IN4 110b = output SPDIF_IN5 111b = output SPDIF_IN6	000
Bit[11]	SPDIF disable	Enables or disables the SPDIF transmitter. 0b = enabled 1b = disabled	0
Bit[10]	PRE edge	Sets the edge to be used for the preamble. 0b = rising edge 1b = falling edge	0
Bit[9]	Validity polarity	Used to indicate to the receiver if the data in the transmitted stream is valid audio data. 0b = valid data sent 1b = invalid data sent	0
Bit[8]	Copy flag	Used to indicate to the receiver if the data is copyright material. 0b = copyright 1b = not copyright	0
Bits[7:0]	Channel status	Used to specify the type of equipment in use; not applicable when the SPDIF Mux Bits[14:12] are set to anything other than 000b.	00000000

# ADAV4601

## Address 0x000A Misc Control Register (Default: 0x0800)

Table 51.

Bit No.	Bit Name	Description	Default
Bit[15]	PWM ready flag (read-only)	Indicates the current status of the PWM ready pin. When PWM ready is low, the PWM is not enabled. When PWM ready is high, the PWM is enabled and stable. 0b = PWM ready pin low 1b = PWM ready pin high	0
Bit[14]	Enable selected PWM channels	When enabled, all PWM channels selected by Bits[10:7] can be used. 0b = all PWM channels disabled 1b = selected PWM channels enabled	0
Bit[13]	MCLK_OUT CLK type select	Used to configure the MCLK_OUT pin. 0b = crystal frequency on MCLK_OUT 1b = internally generated clocks on MCLK_OUT	0
Bit[12]	PWM enable/disable patterns	Enables the enable/disable patterns for the PWM block. 0b = enable/disable pattern not used 1b = use enable/disable pattern	0
Bit[11]	DAC mod offset	Adds dc offset to the DAC $\Sigma$ - $\Delta$ modulator to eliminate idle tones. It is recommended that this bit be disabled before the ADC/DAC engine is powered up in Control Register 0x0007[1]. 0b = enabled 1b = disabled	1
Bit[10]	PWM Enable 4	The PWM outputs are disabled by default, which means that the outputs are at GND. When this bit is set to 1 and Bit[14] of this register is set to 1, then the PWM Enable 4 channel is enabled. 0b = disabled 1b = enabled	0
Bit[9]	PWM Enable 3	The PWM outputs are disabled by default, which means that the outputs are at GND. When this bit is set to 1 and Bit[14] of this register is set to 1, then the PWM Enable 3 channel is enabled. 0b = disabled 1b = enabled	0
Bit[8]	PWM Enable 2	The PWM outputs are disabled by default, which means that the outputs are at GND. When this bit is set to 1 and Bit[14] of this register is set to 1, then the PWM Enable 2 channel is enabled. 0b = disabled 1b = enabled	0
Bit[7]	PWM Enable 1	The PWM outputs are disabled by default, which means that the outputs are at GND. When this bit is set to 1 and Bit[14] of this register is set to 1, then the PWM Enable 1 channel is enabled. 0b = disabled 1b = enabled	0
Bit[6]	SRC2 lock (read-only)	Set to 1 when the sample rate converter (SRC) locks to the incoming data, indicating the data is valid. 0b = not locked 1b = locked	0
Bit[5]	SRC1 lock (read-only)	Set to 1 when the sample rate converter (SRC) locks to the incoming data, indicating the data is valid. 0b = not locked 1b = locked	0
Bit[4]	MCLK_OUT enable	Enables the clock chosen by Bit[13] and Bits[3:1] to be output on the MCLK_OUT pin. 0b = MCLK_OUT function disabled 1b = MCLK_OUT function enabled	0

Bit No.	Bit Name	Description	Default
Bits[3:1]	Select internally generated clock	Selects the frequency of the internally generated clock to be output on the MCLK_OUT pin.  000b = crystal clock from internal PLL 001b = audio processor clock (122.88 MHz/2560 × FS) 010b = engine clock (49.152 MHz/1024 × FS) 011b = SRC clock/2 (24.576 MHz/512 × FS) 1xxb = modulator clock (6.144 MHz/128 × FS)	000
Bit[0]	PLL enable	Enables the PLL. 0b = PLL bypassed 1b = PLL enabled	0

**Address 0x000B Headphone Control Register (Default: 0x0000)**

Table 52.

Bit No.	Bit Name	Description	Default
Bits[15:8]	Reserved	Always write as 0 if writing to this register.	00000000
Bit[7]	HP1 mute	When set to 1, mutes the headphone output immediately without ramping. 0b = unmuted 1b = mute	0
Bit[6]	HP1 short-circuit protect	Enables the short-circuit protection for the headphone amplifier. 0b = disabled 1b = enabled	0
Bit[5]	HP1 tristate	Disables tristating of the headphone amplifier. 0b = enabled 1b = disabled	0
Bits[4:0]	Headphone 1 gain/attenuation	Used to apply analog attenuation to the headphone amplifier. 00000b = 0 dB 00001b = -1.5 dB 00010b = -3 dB ... 11101b = -43.5 dB 11110b = -45 dB 11111b = +1.5 dB	00000

**Address 0x000C Serial Port Control 2 Register (Default: 0x8004)**

It should be noted that SDIN3, LRCLK0, BCLK0, LRCLK1, BCLK1, LRCLK2, and BCLK2 can also be used as SPDIF\_IN0, SPDIF\_IN1, SPDIF\_IN2, SPDIF\_IN3, SPDIF\_IN4, SPDIF\_IN5, and SPDIF\_IN6.

Table 53.

Bit No.	Bit Name	Description	Default
Bits[15:14]	SCR2 clock select	Used to select the serial clocks used for the input to SRC2. 00b = uses LRCLK0 and BCLK0 01b = uses LRCLK1 and BCLK1 10b = uses LRCLK2 and BCLK2 11b = reserved	10
Bits[13:12]	SRC1 clock select	Used to select the serial clocks used for the input to SRC1. 00b = uses LRCLK0 and BCLK0 01b = uses LRCLK1 and BCLK1 10b = uses LRCLK2 and BCLK2 11b = reserved	00
Bit[11]	Reserved	Always write as 0 if writing to this register.	0

# ADAV4601

Bit No.	Bit Name	Description	Default
Bit[10]	Digout Enable 1	Used to change the function of the PWM1A and PWM1B pins to additional serial digital outputs, SDO2 and SDO3. 0b = PWM1A and PWM1B in normal operation 1b = PWM1A and PWM1B used as SDO2 and SDO3	0
Bit[9]	Digout Enable 2	Used to change the function of SPDIF output to serial digital output SDO1. 0b = SPDIF output normal operation 1b = SPDIF output used as SDO1	0
Bits[8:7]	BCLK frequency (master)	Used to set the BCLK frequency when the synchronous serial port is in master mode. 00b = 64 × frequency sample, FS (3.072 MHz) 01b = 128 × FS (6.144 MHz) 10b = 256 × FS (12.288 MHz) 11b = reserved	00
Bits[6:5]	Reserved	Always write as 0 if writing to this register.	00
Bit[4]	Dither enable	When set to 1, it performs dithering on the digital output when the word width is set to 20 bits or 16 bits. This reduces the effect of truncation noise. 0b = disabled 1b = enabled	0
Bits[3:2]	Synchronous port clock select	Used to select the serial clocks used for the synchronous digital inputs. 00b = uses LRCLK0 and BCLK0 01b = uses LRCLK1 and BCLK1 10b = uses LRCLK2 and BCLK2 11b = reserved	0
Bit[1]	8-channel time division multiplexing enable	When set to 1, time division multiplexing mode is enabled.  0b = disabled 1b = enabled	0
Bit[0]	Reserved	Always write as 0 if writing to this register.	0

## Address 0x0018 Audio Mute Control 1 Register (Default: 0x7F00)

Table 54.

Bit No.	Bit Name	Description	Default
Bits[15:8]	PWM output latency	Set the delay from the 50/50 duty-cycle square wave to zero on GND when the output is muted and Bit[5] is set to 1. 0x00 = 1.066 ms 0x01 = 2.133 ms ... 0x5F = 101.33 ms ... 0xFE = 270.93 ms 0xFF = 272 ms	01011111
Bits[7:6]	Reserved	Always write as 0 if writing to this register.	00
Bit[5]	PWM zero enable	Used to specify the final condition of the PWM channels after a mute. 0b = PWM not zeroed after audio mute 1b = PWM zeroed after audio mute	0
Bit[4]	Mute clear select	Mute clear select bit. When the mute pin is used to mute the device, the part can be unmuted in two ways, depending on the condition of this bit. 0b = mute pin rising edge clears mute bit 1b = mute clear gated by clear mute bit	0
Bit[3]	Audio mute	Used to control the software mute. 0b = unmute 1b = mute	0

Bit No.	Bit Name	Description	Default
Bit[2]	Clear mute	Set to 1 to unmute the ADAV4601 when the external pin has been used to mute the part and the mute clear select bit is set. Having performed the required action, this bit automatically resets to 0. 0b = no change 1b = clear pin mute	0
Bit[1]	Mute status (read-only)	Displays the status of the ADAV4601 mute. 0b = currently unmuting or unmuted 1b = currently muting or muted	0
Bit[0]	Mute flag (read-only)	Set to 1 when the ADAV4601 is in mute. 0b = unmuted 1b = muted	0

**Address 0x0019 PWM Status Register (Default: 0x0000)**

Table 55.

Bit No.	Bit Name	Description	Default
Bits[15:4]	Reserved	Always write as 0 if writing to this register.	000000000000
Bit[3]	PWM4 status	Set when the PWM4 outputs have gone from zero to 50/50 duty cycle. 0b = PWM4 disabled 1b = PWM4 enabled	0
Bits[2]	PWM3 status	Set when the PWM3 outputs have gone from zero to 50/50 duty cycle. 0b = PWM3 disabled 1b = PWM3 enabled	0
Bits[1]	PWM2 status	Set when the PWM2 outputs have gone from zero to 50/50 duty cycle. 0b = PWM2 disabled 1b = PWM2 enabled	0
Bit[0]	PWM1 status	Set when the PWM1 outputs have gone from zero to 50/50 duty cycle. 0b = PWM1 disabled 1b = PWM1 enabled	0

**Address 0x001F PWM Control Register (Default: 0x1070)**

Table 56.

Bit No.	Bit Name	Description	Default
Bits[15:14]	PWM ready configure	00b = PWM ready forced low 01b = PWM ready forced high 10b = PWM ready late 11b = PWM ready early	00
Bit[13]	Reserved	Always write as 0 if writing to this register.	0
Bit[12]	Reserved	Always write a 1 if writing to this register	1
Bits[11:7]	Reserved	Always write as 0 if writing to this register.	00000
Bits[6:4]	Reserved	Always write a 1 if writing to this register.	111
Bits[3:0]	Reserved	Always write as 0 if writing to this register.	0000

# ADAV4601

## Address 0x008A SRC Configuration 3 Register (Default: 0x0032)

Table 57.

Bit No.	Bit Name	Description	Default
Bits[15:7]	Reserved	Always write as 0 if writing to this register.	00000000
Bit[6]	SRC2 Channel C enable	Used to enable Channel C of SRC2. 0b = disabled 1b = enabled	0
Bits[5:4]	SRC2 Channel C input select	Used to select the serial data input for SRC2 Channel C. 00b = SDIN0 01b = SDIN1 10b = SDIN2 11b = SDIN3	11
Bit[3]	Reserved	Always write as 0 if writing to this register.	0
Bit[2]	SRC2C Channel B enable	Used to enable Channel B of SRC2. 0b = disabled 1b = enabled	0
Bits[1:0]	SRC2C Channel B input select	Used to select the serial data input for SRC2 Channel B. 00b = SDIN0 01b = SDIN1 10b = SDIN2 11b = SDIN3	10

## Address 0x008E SPDIF Transmitter Control 2 Register (Default: 0x002D)

Table 58.

Bit No.	Bit Name	Description	Default
Bits[15:8]	Reserved	Always write as 0 if writing to this register.	00000000
Bits[7:4]	Channel status sampling frequency	Used to set the channel status sampling rate in the SPDIF transmitted stream; should not change the sample rate but only the status bits. 0x0 = 44.1 kHz 0x2 = 48 kHz 0x3 = 32 kHz	0010
Bit[3]	SPDIF TX word length field size	Selects the maximum SPDIF transmitter word length. 0b = 20 bits maximum 1b = 24 bits maximum	1
Bits[2:0]	Transmitter word length	Used to select how many of the bits set by Bit[3] carry valid data. If 24-bit maximum 0x5 = 24 bits 0x4 = 23 bits 0x2 = 22 bits 0x6 = 21 bits 0x1 = 20 bits If 20-bit maximum 0x5 = 20 bits 0x4 = 19 bits 0x2 = 18 bits 0x6 = 17 bits 0x1 = 16 bits	101



**Address 0x0200 EEPROM Self Boot Control Register (Default: 0x0000)**

Table 59.

Bit No.	Bit Name	Description	Default
Bits[15]	Self-boot enable	It initiates a self-boot from the external EEPROM. 0b = normal operation 1b = initiates self-boot	0
Bits[14:6]	Reserved	Always write as 0 if writing to this register.	000000000
Bit[5]	Safe load target/slew RAM	Initiates a safe load to the target/slew RAM; cleared when safe load completed. 0b = finished 1b = safe load request	0
Bit[4]	Safe load parameter RAM	Initiates a safe load to the parameter RAM; cleared when safe load completed. 0b = finished 1b = safe load request	0
Bits[3:0]	Reserved	Always write as 0 if writing to this register.	0000

**Address 0x0316 EEPROM Device Address Register (Default: 0x0050)**

Table 60.

Bit No.	Bit Name	Description	Default
Bits[15:7]	Reserved	Always write as 0 if writing to this register.	000000000
Bits[6:0]	EEPROM device address	0x50 = sets external EEPROM address	1010000

**Address 0x0317 EEPROM Data Address Register (Default: 0x0000)**

Table 61.

Bit No.	Bit Name	Description	Default
Bits[15:0]	EEPROM start address	0x0000 = default address	0000000000000000

OUTLINE DIMENSIONS

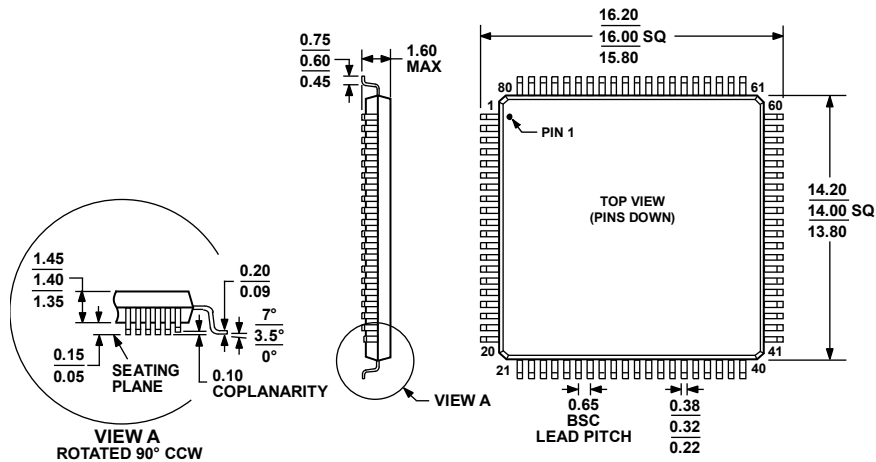

COMPLIANT TO JEDEC STANDARDS MS-026-BEC

Figure 49. 80-Lead Low Profile Quad Flat Package [LQFP] (ST-80-2)

Dimensions shown in millimeters

051706-A

ORDERING GUIDE

Model	Temperature Range	Package Description	Package Option
ADAV4601BSTZ <sup>1</sup>	-40°C to +85°C	80-Lead Low Profile Quad Flat Package [LQFP]	ST-80-2
EVAL-ADAV4601EBZ <sup>1</sup>		Evaluation Board	

<sup>1</sup> Z = RoHS Compliant Part. The ADAV4601 is a Pb-free, environmentally friendly product. It is manufactured using the most up-to-date materials and processes. The coating on the leads of each device is 100% pure Sn electroplate. The device is suitable for Pb-free applications and can withstand surface-mount soldering at up to 255°C (±5°C). In addition, it is backward compatible with conventional SnPb soldering processes. This means the electroplated Sn coating can be soldered with Sn/Pb solder pastes at conventional reflow temperatures of 220°C to 235°C.

**NOTES**