

REV	ECO#	DESCRIPTION	DATE

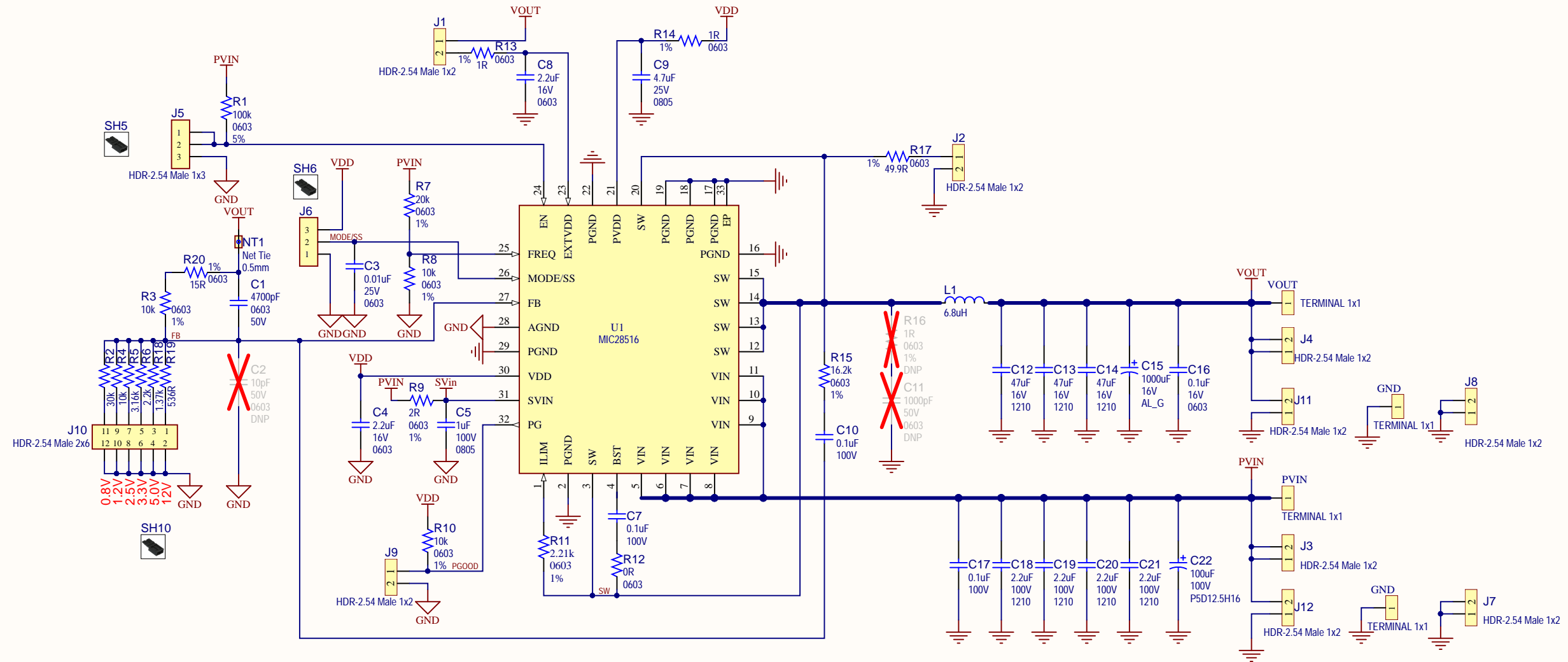

Heatsink



Screw Nylon
SCREW Nylon #6-32 x 1/4"

STANDOFF1 STANDOFF2 STANDOFF3 STANDOFF4

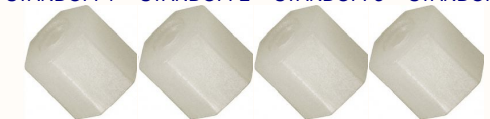

STAND-OFF Nylon #6-32 x 3/8"

LABEL1

Need Help?
<http://support.microchip.com>

Microchip
Assy# Serial #

Label Need Help Large

Drawn By: Sergiu Gheorghe		
Engineer: Sergiu Gheorghe		
PartNumber: ADM00929	Project Title MIC28516 Evaluation Board	
Sheet Title MIC28516 Evaluation Board		
Size B	Sch #03-10825-1 Revision:1.1	Date: 6/26/2020 2:01:00 PM Sheet 1 of 1
File: MIC28516.SchDoc		

Designed with Altium.com