

REV	ECO#	DESCRIPTION	DATE

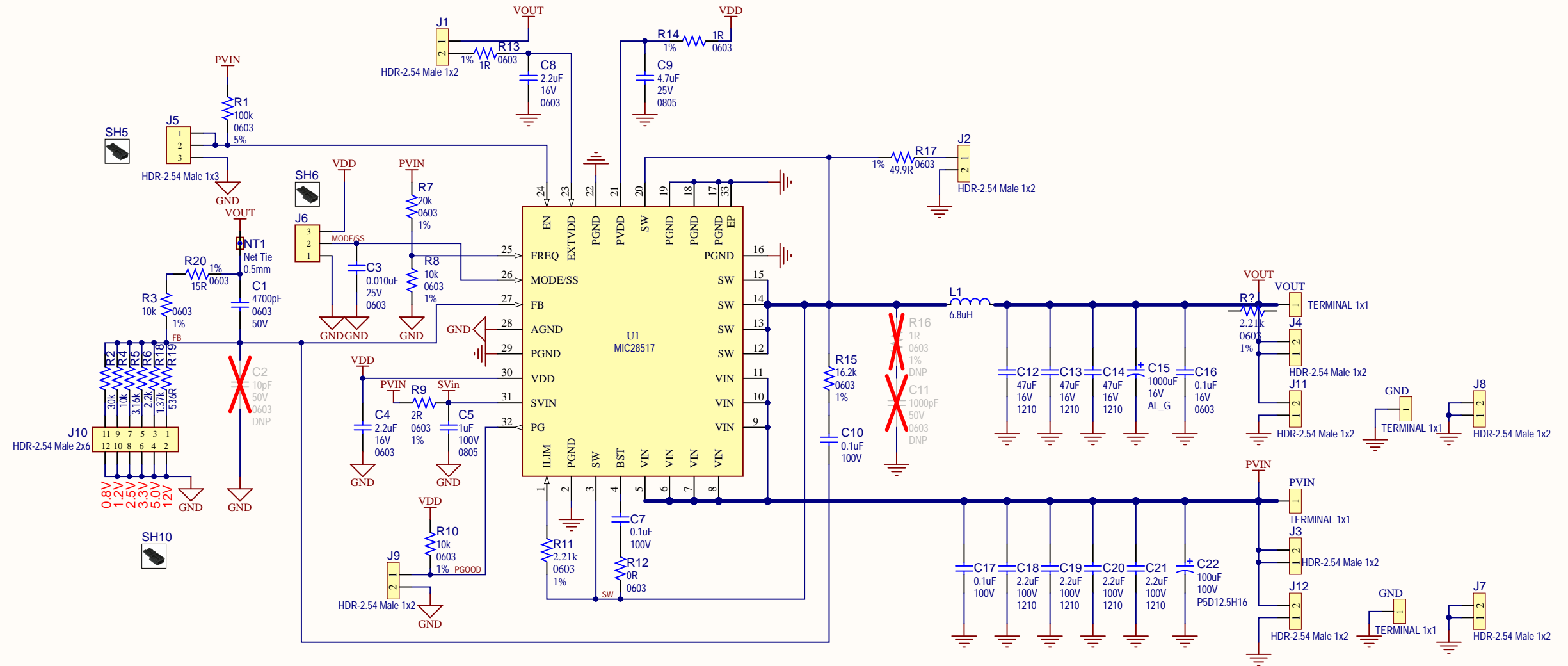

Heatsink



Screw Nylon  
SCREW Nylon #6-32 x 1/4"



STAND-OFF Nylon #6-32 x 3/8"



Label Need Help Large

Drawn By: Sergiu Gheorghe		
Engineer: Sergiu Gheorghe		
PartNumber: ADM00995	Project Title <b>MIC28517 Evaluation Board</b>	
Sheet Title MIC28517 Evaluation Board		
Size B	Sch #03-10825-2 Revision:1.1	Date: 6/26/2020 2:55:49 PM Sheet 1 of 1
File: MIC28517.SchDoc		

