



MCP1663
Mini-Module SEPIC Converter
Evaluation Board
User's Guide

Note the following details of the code protection feature on Microchip devices:

- Microchip products meet the specification contained in their particular Microchip Data Sheet.
- Microchip believes that its family of products is one of the most secure families of its kind on the market today, when used in the intended manner and under normal conditions.
- There are dishonest and possibly illegal methods used to breach the code protection feature. All of these methods, to our knowledge, require using the Microchip products in a manner outside the operating specifications contained in Microchip's Data Sheets. Most likely, the person doing so is engaged in theft of intellectual property.
- Microchip is willing to work with the customer who is concerned about the integrity of their code.
- Neither Microchip nor any other semiconductor manufacturer can guarantee the security of their code. Code protection does not mean that we are guaranteeing the product as "unbreakable."

Code protection is constantly evolving. We at Microchip are committed to continuously improving the code protection features of our products. Attempts to break Microchip's code protection feature may be a violation of the Digital Millennium Copyright Act. If such acts allow unauthorized access to your software or other copyrighted work, you may have a right to sue for relief under that Act.

Information contained in this publication regarding device applications and the like is provided only for your convenience and may be superseded by updates. It is your responsibility to ensure that your application meets with your specifications. MICROCHIP MAKES NO REPRESENTATIONS OR WARRANTIES OF ANY KIND WHETHER EXPRESS OR IMPLIED, WRITTEN OR ORAL, STATUTORY OR OTHERWISE, RELATED TO THE INFORMATION, INCLUDING BUT NOT LIMITED TO ITS CONDITION, QUALITY, PERFORMANCE, MERCHANTABILITY OR FITNESS FOR PURPOSE. Microchip disclaims all liability arising from this information and its use. Use of Microchip devices in life support and/or safety applications is entirely at the buyer's risk, and the buyer agrees to defend, indemnify and hold harmless Microchip from any and all damages, claims, suits, or expenses resulting from such use. No licenses are conveyed, implicitly or otherwise, under any Microchip intellectual property rights unless otherwise stated.

Microchip received ISO/TS-16949:2009 certification for its worldwide headquarters, design and wafer fabrication facilities in Chandler and Tempe, Arizona; Gresham, Oregon and design centers in California and India. The Company's quality system processes and procedures are for its PIC[®] MCUs and dsPIC[®] DSCs, KEELOQ[®] code hopping devices, Serial EEPROMs, microperipherals, nonvolatile memory and analog products. In addition, Microchip's quality system for the design and manufacture of development systems is ISO 9001:2000 certified.

**QUALITY MANAGEMENT SYSTEM
CERTIFIED BY DNV
= ISO/TS 16949 =**

Trademarks

The Microchip name and logo, the Microchip logo, AnyRate, AVR, AVR logo, AVR Freaks, BitCloud, chipKIT, chipKIT logo, CryptoMemory, CryptoRF, dsPIC, FlashFlex, flexPWR, Helder, JukeBlox, KeeLoq, Klear, LANCheck, LINK MD, maXStylus, maXTouch, MediaLB, megaAVR, MOST, MOST logo, MPLAB, OptoLyzer, PIC, picoPower, PICSTART, PIC32 logo, Prochip Designer, QTouch, SAM-BA, SpyNIC, SST, SST Logo, SuperFlash, tinyAVR, UNI/O, and XMEGA are registered trademarks of Microchip Technology Incorporated in the U.S.A. and other countries.

ClockWorks, The Embedded Control Solutions Company, EtherSynch, Hyper Speed Control, HyperLight Load, IntellIMOS, mTouch, Precision Edge, and Quiet-Wire are registered trademarks of Microchip Technology Incorporated in the U.S.A.

Adjacent Key Suppression, AKS, Analog-for-the-Digital Age, Any Capacitor, AnyIn, AnyOut, BodyCom, CodeGuard, CryptoAuthentication, CryptoAutomotive, CryptoCompanion, CryptoController, dsPICDEM, dsPICDEM.net, Dynamic Average Matching, DAM, ECAN, EtherGREEN, In-Circuit Serial Programming, ICSP, INICnet, Inter-Chip Connectivity, JitterBlocker, KlearNet, KlearNet logo, memBrain, Mindi, MiWi, motorBench, MPASM, MPF, MPLAB Certified logo, MPLIB, MPLINK, MultiTRAK, NetDetach, Omniscient Code Generation, PICDEM, PICDEM.net, PICKit, PICtail, PowerSmart, PureSilicon, QMatrix, REAL ICE, Ripple Blocker, SAM-ICE, Serial Quad I/O, SMART-I.S., SQI, SuperSwitcher, SuperSwitcher II, Total Endurance, TSHARC, USBCheck, VariSense, ViewSpan, WiperLock, Wireless DNA, and ZENA are trademarks of Microchip Technology Incorporated in the U.S.A. and other countries.

SQTP is a service mark of Microchip Technology Incorporated in the U.S.A.

Silicon Storage Technology is a registered trademark of Microchip Technology Inc. in other countries.

GestIC is a registered trademark of Microchip Technology Germany II GmbH & Co. KG, a subsidiary of Microchip Technology Inc., in other countries.

All other trademarks mentioned herein are property of their respective companies.

© 2019, Microchip Technology Incorporated, All Rights Reserved.

ISBN:



MCP1663 MINI-MODULE SEPIC CONVERTER EVALUATION BOARD USER'S GUIDE

Table of Contents

Preface	3
Introduction.....	3
Document Layout	3
Conventions Used in this Guide	4
Recommended Reading.....	5
The Microchip Website	5
Customer Support	5
Document Revision History	5
Chapter 1. Product Overview	
1.1 Introduction	7
1.2 MCP1663 Short Overview	7
1.3 What is the MCP1663 Mini-Module SEPIC Converter Evaluation Board?	8
1.4 What the MCP1663 Mini-Module SEPIC Converter Evaluation Board Kit Contains	9
Chapter 2. Installation and Operation	
2.1 Introduction	11
2.2 Getting Started	12
Appendix A. Schematic and Layouts	
A.1 Introduction	15
A.2 Board – Schematic	16
A.3 Board – Top Silk	17
A.4 Board – Top Copper and Silk	17
A.5 Board – Top Copper	17
A.6 Board – Bottom Copper	18
A.7 Board – Bottom Copper and Silk	18
A.8 Board – Bottom Silk	18
Appendix B. Bill of Materials (BOM)	
Worldwide Sales and Service	20

MCP1663 Mini-Module SEPIC Converter Evaluation Board User's Guide

NOTES:



MCP1663 MINI-MODULE SEPIC CONVERTER EVALUATION BOARD USER'S GUIDE

Preface

NOTICE TO CUSTOMERS

All documentation becomes dated, and this manual is no exception. Microchip tools and documentation are constantly evolving to meet customer needs, so some actual dialogs and/or tool descriptions may differ from those in this document. Please refer to our website (www.microchip.com) to obtain the latest documentation available.

Documents are identified with a “DS” number. This number is located on the bottom of each page, in front of the page number. The numbering convention for the DS number is “DSXXXXXXXXA”, where “XXXXXXXX” is the document number and “A” is the revision level of the document.

For the most up-to-date information on development tools, see the MPLAB® IDE online help. Select the Help menu, and then Topics, to open a list of available online help files.

INTRODUCTION

This chapter contains general information that will be useful to know before using the MCP1663 Mini-Module SEPIC Converter Evaluation Board. Items discussed in this chapter include:

- [Document Layout](#)
- [Conventions Used in this Guide](#)
- [Recommended Reading](#)
- [The Microchip Website](#)
- [Customer Support](#)
- [Document Revision History](#)

DOCUMENT LAYOUT

This document describes how to use the MCP1663 Mini-Module SEPIC Converter Evaluation Board as a development tool. The manual layout is as follows:

- **Chapter 1. “Product Overview”** – Important information about the MCP1663 Mini-Module SEPIC Converter Evaluation Board.
- **Chapter 2. “Installation and Operation”** – Includes instructions on how to get started with the MCP1663 Mini-Module SEPIC Converter Evaluation Board and a description of the user’s guide.
- **Appendix A. “Schematic and Layouts”** – Shows the schematic and layout diagrams for the MCP1663 Mini-Module SEPIC Converter Evaluation Board.
- **Appendix B. “Bill of Materials (BOM)”** – Lists the parts used to build the MCP1663 Mini-Module SEPIC Converter Evaluation Board.

CONVENTIONS USED IN THIS GUIDE

This manual uses the following documentation conventions:

DOCUMENTATION CONVENTIONS

Description	Represents	Examples
Arial font:		
Italic characters	Referenced books	<i>MPLAB® IDE User's Guide</i>
	Emphasized text	...is the <i>only</i> compiler...
Initial caps	A window	the Output window
	A dialog	the Settings dialog
	A menu selection	select Enable Programmer
Quotes	A field name in a window or dialog	"Save project before build"
Underlined, italic text with right angle bracket	A menu path	<u><i>File</i></u> >Save
Bold characters	A dialog button	Click OK
	A tab	Click the Power tab
N'Rnnnn	A number in verilog format, where N is the total number of digits, R is the radix and n is a digit.	4'b0010, 2'hF1
Text in angle brackets < >	A key on the keyboard	Press <Enter>, <F1>
Courier New font:		
Plain Courier New	Sample source code	#define START
	Filenames	autoexec.bat
	File paths	c:\mcc18\h
	Keywords	_asm, _endasm, static
	Command-line options	-Opa+, -Opa-
	Bit values	0, 1
	Constants	0xFF, 'A'
Italic Courier New	A variable argument	<i>file.o</i> , where <i>file</i> can be any valid filename
Square brackets []	Optional arguments	mcc18 [options] <i>file</i> [options]
Curly brackets and pipe character: { }	Choice of mutually exclusive arguments; an OR selection	errorlevel {0 1}
Ellipses...	Replaces repeated text	var_name [, var_name...]
	Represents code supplied by user	void main (void) { ... }

RECOMMENDED READING

This user's guide describes how to use the MCP1663 Mini-Module SEPIC Converter Evaluation Board. Other useful documents are listed below. The following Microchip documents are available and recommended as a supplemental reference resource:

- **MCP1663 Data Sheet – “High-Voltage Integrated Switch PWM Boost Regulator with UVLO” (DS20005406)**
- **AN2085 – “Designing Applications with MCP166X High Output Voltage Boost Converter Family” (DS00002085)**

THE MICROCHIP WEBSITE

Microchip provides online support via our website at www.microchip.com. This website is used as a means to make files and information easily available to customers. Accessible by using your favorite Internet browser, the website contains the following information:

- **Product Support** – Data sheets and errata, application notes and sample programs, design resources, user's guides and hardware support documents, latest software releases and archived software
- **General Technical Support** – Frequently Asked Questions (FAQs), technical support requests, online discussion groups, Microchip consultant program member listing
- **Business of Microchip** – Product selector and ordering guides, latest Microchip press releases, listing of seminars and events, listings of Microchip sales offices, distributors and factory representatives

CUSTOMER SUPPORT

Users of Microchip products can receive assistance through several channels:

- Distributor or Representative
- Local Sales Office
- Field Application Engineer (FAE)
- Technical Support

Customers should contact their distributor, representative or field application engineer (FAE) for support. Local sales offices are also available to help customers. A listing of sales offices and locations is included in the back of this document.

Technical support is available through the website at:

<http://www.microchip.com/support>.

DOCUMENT REVISION HISTORY

Revision A (February 2019)

- Initial release of this document

MCP1663 Mini-Module SEPIC Converter Evaluation Board User's Guide

NOTES:

Chapter 1. Product Overview

1.1 INTRODUCTION

This chapter provides an overview of the MCP1663 Mini-Module SEPIC Converter Evaluation Board and covers the following topics:

- [MCP1663 Short Overview](#)
- [What is the MCP1663 Mini-Module SEPIC Converter Evaluation Board?](#)
- [What the MCP1663 Mini-Module SEPIC Converter Evaluation Board Kit Contains](#)

1.2 MCP1663 SHORT OVERVIEW

The MCP1663 is a compact, high-efficiency, fixed-frequency, non-synchronous step-up DC-DC converter which integrates a 36V, 400 mΩ switch. This product provides a space-efficient, high-voltage step-up, easy-to-use power supply solution and is configurable in various DC-DC topologies.

The MCP1663 offers the advantage of a minimum number of external components for applications powered by two-cell or three-cell alkaline, Ultimate Lithium®, Ni-Cd, Ni-MH, one-cell Li-Ion or Li-Polymer batteries.

The MCP1663 operates in Pulse-Width Modulation (PWM), at a fixed 500 kHz switching frequency. The device features an Undervoltage Lockout (UVLO), which prevents Fault operation below 1.85V typical (UVLO Stop), corresponding to the value of two discharged alkaline batteries. The MCP1663 starts its normal operation at 2.3V input voltage, typically (UVLO Start), and the operating input voltage ranges up to 5.5V.

For standby applications, MCP1663 can be turned off by pulling the EN pin to GND. The device will stop switching and will consume 300 nA of input current. Note that, while in Shutdown mode, the input voltage will be bypassed to the output through the inductor and the Schottky diode. In the Step-Up/Step-Down configuration, using a SEPIC (Single-Ended Primary Inductor Converter), there is no direct path from input to output. Connecting the EN pin to GND will provide an output disconnect.

MCP1663 also provides overvoltage protection (OVP) in the event of:

- Short-circuit of the feedback pin to GND
- Disconnected feedback divider from V_{OUT}

In these conditions, the OVP will stop the switching and will prevent damage to the device. This feature is disabled during the start-up sequence and thermal shutdown.

The goal of the MCP1663 Mini-Module SEPIC Converter Evaluation Board is to demonstrate the capabilities of the MCP1663 device used in the SEPIC topology for applications designed in a very small form factor like the DDPACK package.

1.2.1 SEPIC TOPOLOGY

The SEPIC topology is commonly used in battery-powered devices as it requires the minimum number of components in order to develop a DC-DC power converter that provides a positive regulated output voltage from either a lower or a higher input voltage. This type of converter follows the flyback design, adding a coupling capacitor between the windings of the transformer.

The SEPIC topology can use either two single inductors with separate windings or a coupled inductor, with both windings on the same core. The difference between the two types of inductors is small, from the circuit operation point of view. The uncoupled inductors solution offers better output current capabilities, but might require a bigger area on the PCB. This is very dependent on 1:1 coupled inductors available on the market vs. load current requirements. This evaluation board offers a good trade-off solution with regards to both size and performance.

This converter eliminates the need for a snubber circuit. The extra active clamping circuit is removed with a capacitor connected between the first and the second inductor. The capacitor clamps the winding leakage inductance energy, offers DC isolation and protection against a shorted load. The input inductor smooths the current draw from the battery and reduces the required input filtering.

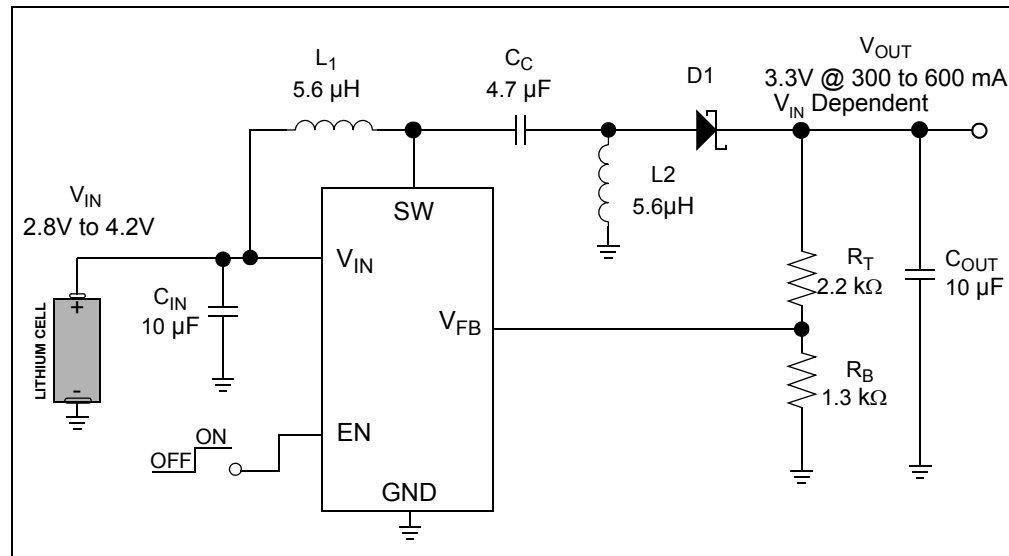

FIGURE 1-1: Typical MCP1663 SEPIC Converter.

1.3 WHAT IS THE MCP1663 MINI-MODULE SEPIC CONVERTER EVALUATION BOARD?

The MCP1663 Mini-Module SEPIC Converter Evaluation Board is used to evaluate Microchip Technology's MCP1663 product. This board demonstrates the capabilities of the MCP1663 SEPIC converter, which has its output voltage set to 3.3V and is designed in a very small form factor (DDPAK package), as shown in [Figure 1-2](#). The size plays an important role in every application where space is one of the constraints.

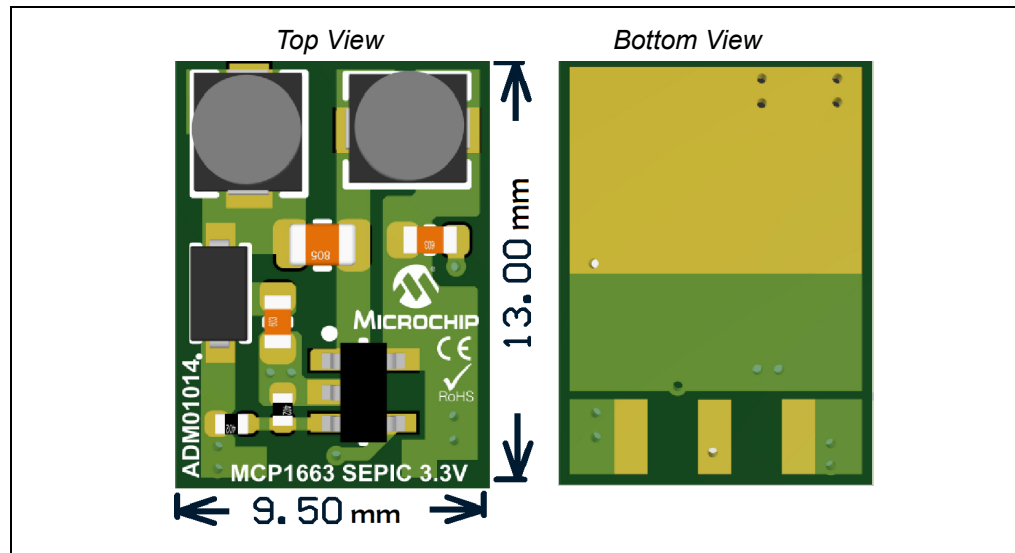

FIGURE 1-2: MCP1663 Mini-Module SEPIC Converter Evaluation Board.

The MCP1663 Mini-Module SEPIC Converter Evaluation Board was developed to help engineers reduce the product design cycle time.

Another important feature of this evaluation board is that it has the EN pin accessible and can be controlled from an MCU or another device. The EN pin is a logic-level input and will enable the regulator's output when its voltage is greater than 85% of V_{IN} . When this pin is set low or connected to ground, the SEPIC converter enters Output Disconnect mode.

In this application, the output voltage is set to the proper value by using an external resistor divider, resulting in a simple and compact solution.

1.4 WHAT THE MCP1663 MINI-MODULE SEPIC CONVERTER EVALUATION BOARD KIT CONTAINS

The MCP1663 Mini-Module SEPIC Converter Evaluation Board kit includes the following items:

- MCP1663 Mini-Module SEPIC Converter Evaluation Board (ADM01014)
- Important Information Sheet

MCP1663 Mini-Module SEPIC Converter Evaluation Board User's Guide

NOTES:

Chapter 2. Installation and Operation

2.1 INTRODUCTION

MCP1663 is a non-synchronous, fixed-frequency step-up DC/DC converter that has been developed for applications that require higher output voltage capabilities. MCP1663 can regulate the output voltage up to 32V and can deliver 250 mA load at 3.3V input and 12V output. At light loads, MCP1663 skips pulses to keep the output ripple low.

Another important feature is that the device integrates the compensation and protection circuitry so that the final solution lowers the total system cost, eases the implementation and requires a minimum number of additional components and a small board area.

The SEPIC topology is used to provide a positive regulated 3.3V output voltage from an input voltage that varies from a minimum of 2.3V to a maximum of 5V. Refer to [Figure 2-1](#) for the maximum output current that can be obtained for different input voltages.

The DDPACK footprint brings an advantage in terms of performance, as the design was optimized for both high efficiency and maximum output current capabilities, while keeping a small form factor of the module.

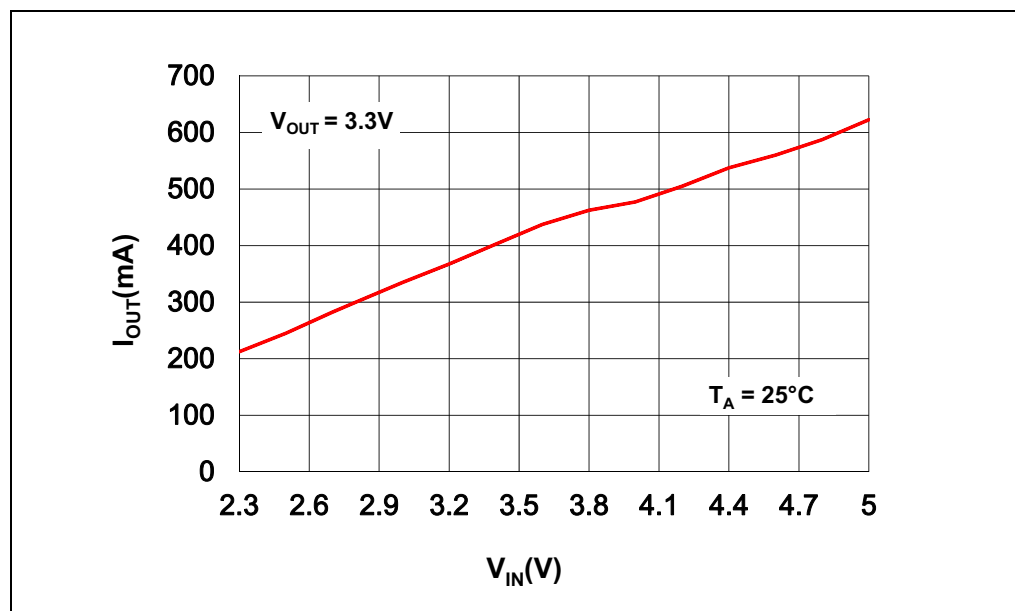

FIGURE 2-1: MCP1663 SEPIC - 3.3V V_{OUT} Maximum I_{OUT} vs. V_{IN} Using a Power Supply.

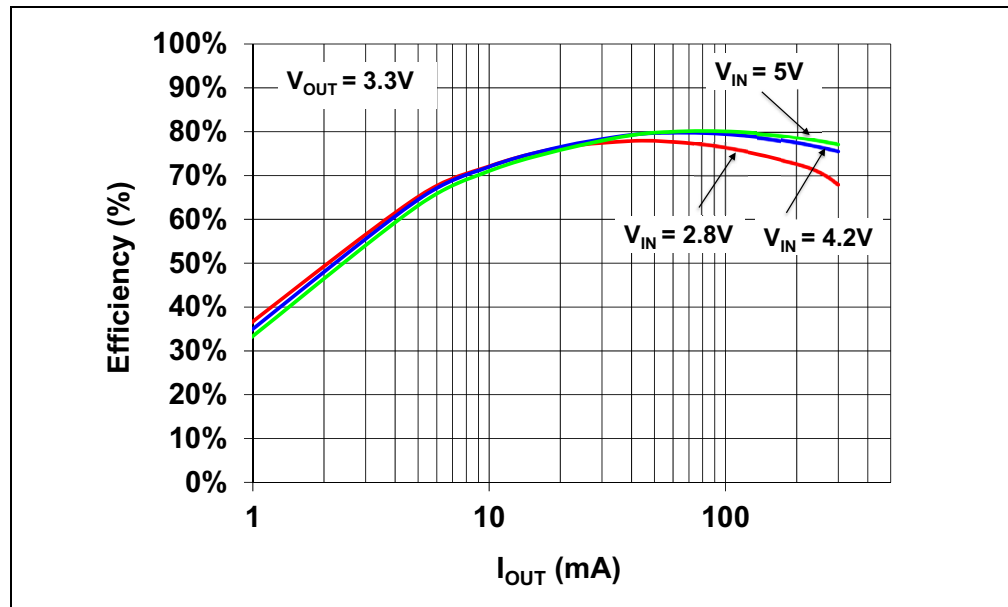

FIGURE 2-2: MCP1663 SEPIC 3.3V V_{OUT} Mode Efficiency vs. I_{OUT} .

2.1.1 MCP1663 Mini-Module SEPIC Converter Evaluation Board Features

The MCP1663 Mini-Module SEPIC Converter Evaluation Board has the following features:

- Undervoltage Lockout (UVLO): 1.85V (typical)
- Start-up Voltage: 2.3V (UVLO Start)
- Input Voltage Range (V_{IN}) after start-up: 1.85V to 5.5V
- Output Voltage: 3.3V
- Output Current: 300 mA @ 3.3V Output, 2.8V Input; refer to [Figure 2-1](#)
- PWM Operation
- Switching Frequency: 500 kHz
- Peak Input Current Limit: 1.8A
- Internal Compensation
- Soft Start
- Overtemperature Protection (if the die temperature exceeds +150°C, with 15°C hysteresis)
- Small Size Package: 13 mm x 9.5 mm (DDPAK)

2.2 GETTING STARTED

The MCP1663 Mini-Module SEPIC Converter Evaluation Board is fully assembled and tested to evaluate the MCP1663 product and demonstrate its capabilities. This board requires the use of external laboratory power supplies and load.

The mini-module's performance was tested using a motherboard which includes a DDPAK footprint, as shown in [Figure 2-3](#). All measurements presented in this document were performed by utilizing this motherboard.

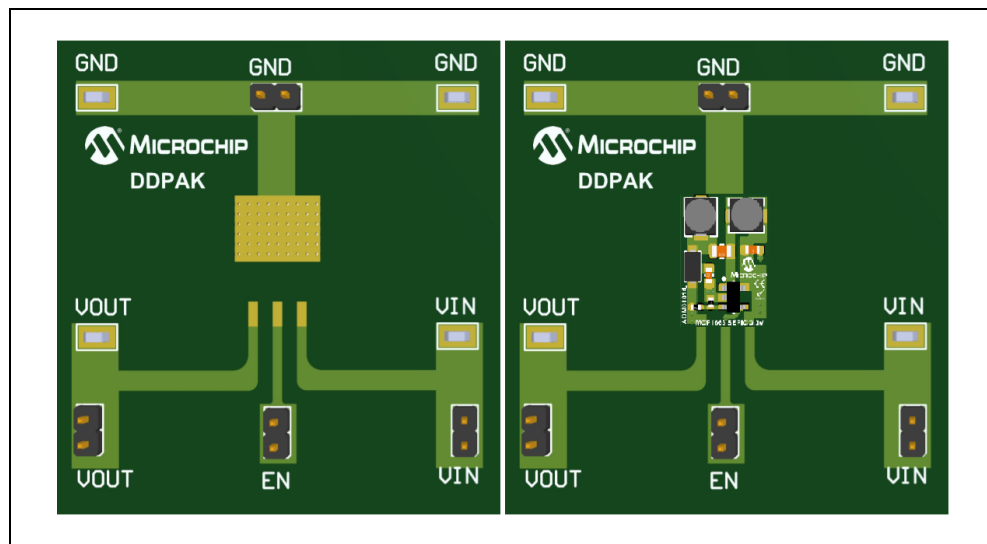

FIGURE 2-3: Motherboard Used to Evaluate the Mini-Module with DDPAK Footprint.

2.2.1 Power Input and Output Connection

2.2.1.1 POWERING MCP1663 MINI-MODULE SEPIC CONVERTER EVALUATION BOARD

The MCP1663 Mini-Module SEPIC Converter Evaluation pin information is presented below.

DDPAK 13 x 9.5 mm	Symbol	Description
1	V_{IN}	Input Voltage Pin
2	EN	Enable Control Input Pin
3	V_{OUT}	Output Voltage Pin
4	GND	Ground Pin

Bottom View

FIGURE 2-4: MCP1663 SEPIC DDPAK Mini-Module Bottom View and Pins Description.

Surface mounted pads are available for input voltage, output load and ground connections. The maximum applied input voltage should not exceed 5.5V.

Soldered pads are available in order to allow connecting a load. The peak current limit of the MCP1663 will provide a safe maximum current value. The maximum output current for the converter will vary with the input voltage, as shown in [Figure 2-1](#).

2.2.1.2 BOARD POWER-UP PROCEDURE

1. Connect the power supply as shown in [Figure 2-5](#).
2. Connect the Enable pin to the V_{IN} pin; refer to [Figure 2-4](#).
3. Connect the load between the V_{OUT} and GND terminals (pads). This can be either a 33Ω resistor or an electronic load set to 100 mA.
4. Set the input voltage to 2.5V and turn on the power supply. Use the voltmeter to measure V_{OUT} . The output voltage must be regulated around 3.3V ($\pm 5\%$).
5. Change the input voltage in the range of 1.85V to 5V and check if V_{OUT} stays regulated. With the V_{IN} below 1.6V, the output voltage of the mini-module should drop to around 0V.

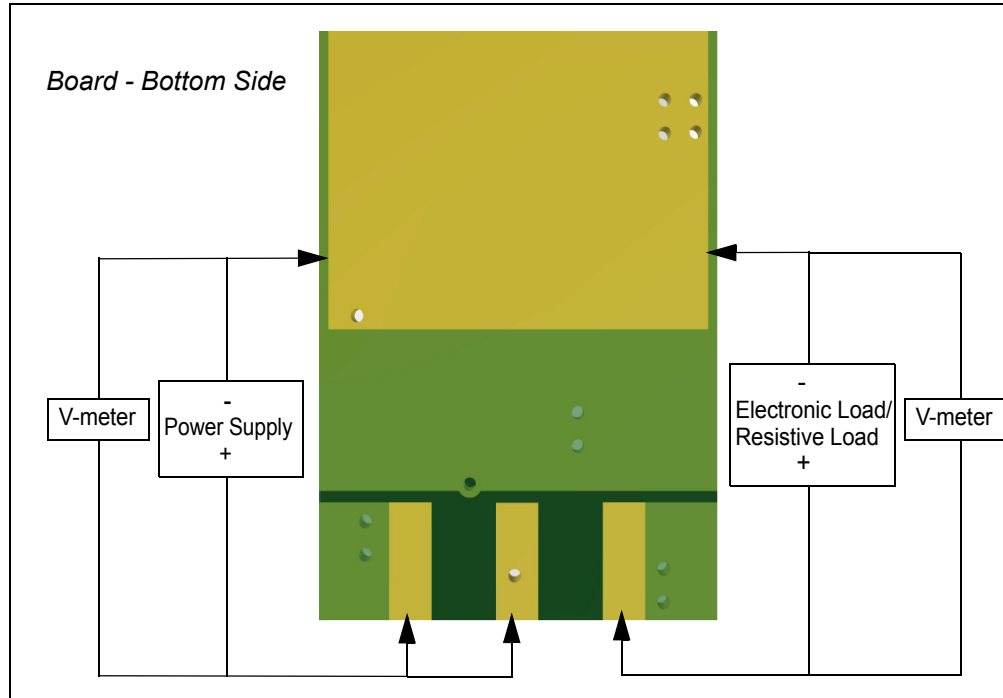

FIGURE 2-5: MCP1663 Mini-Module SEPIC Converter Evaluation Board Setup.



MCP1663 MINI-MODULE SEPIC CONVERTER EVALUATION BOARD USER'S GUIDE

Appendix A. Schematic and Layouts

A.1 INTRODUCTION

This appendix contains the following schematics and layouts for the MCP1663 Mini-Module SEPIC Converter Evaluation Board - ADM01014:

- [Board – Schematic](#)
- [Board – Top Silk](#)
- [Board – Top Copper and Silk](#)
- [Board – Top Copper](#)
- [Board – Bottom Copper](#)
- [Board – Bottom Copper and Silk](#)
- [Board – Bottom Silk](#)

A.2 BOARD – SCHEMATIC

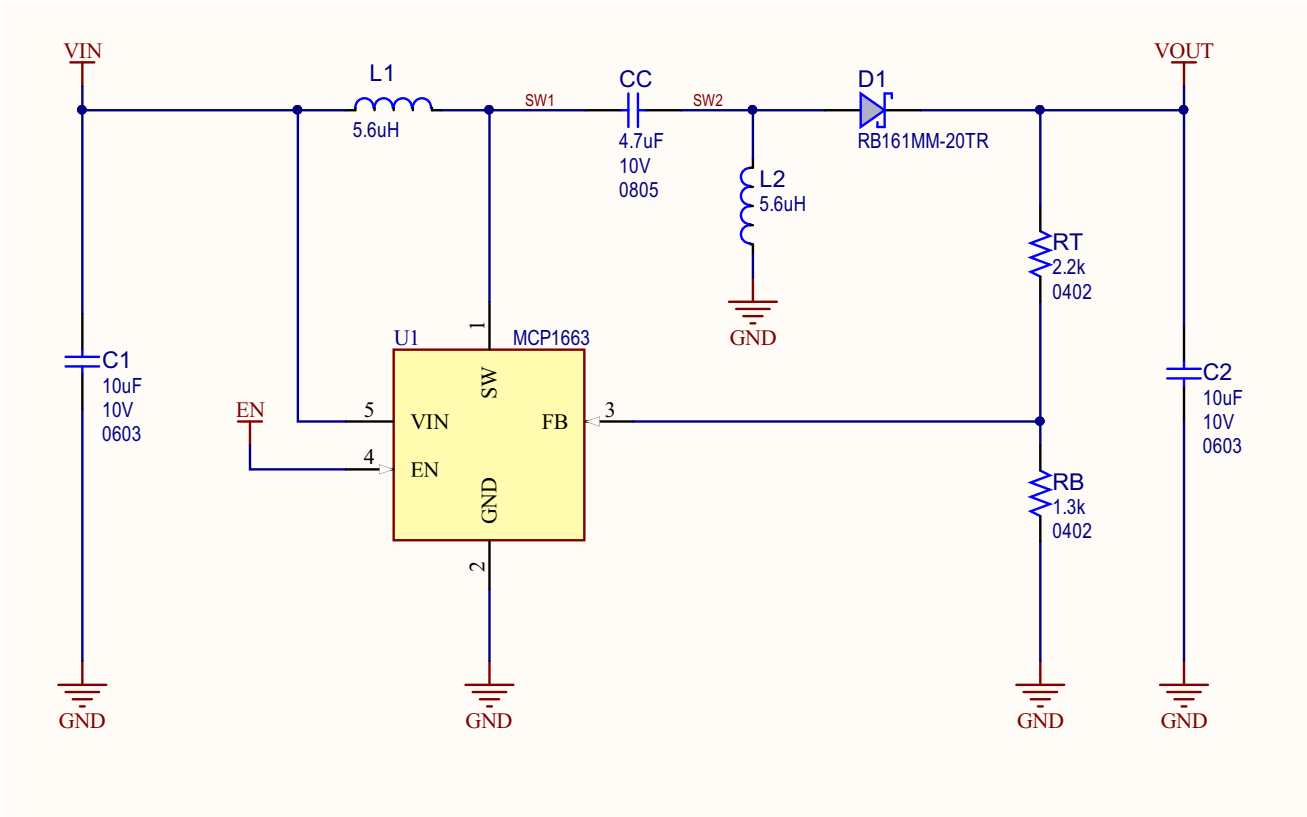

A.3 BOARD – TOP SILK

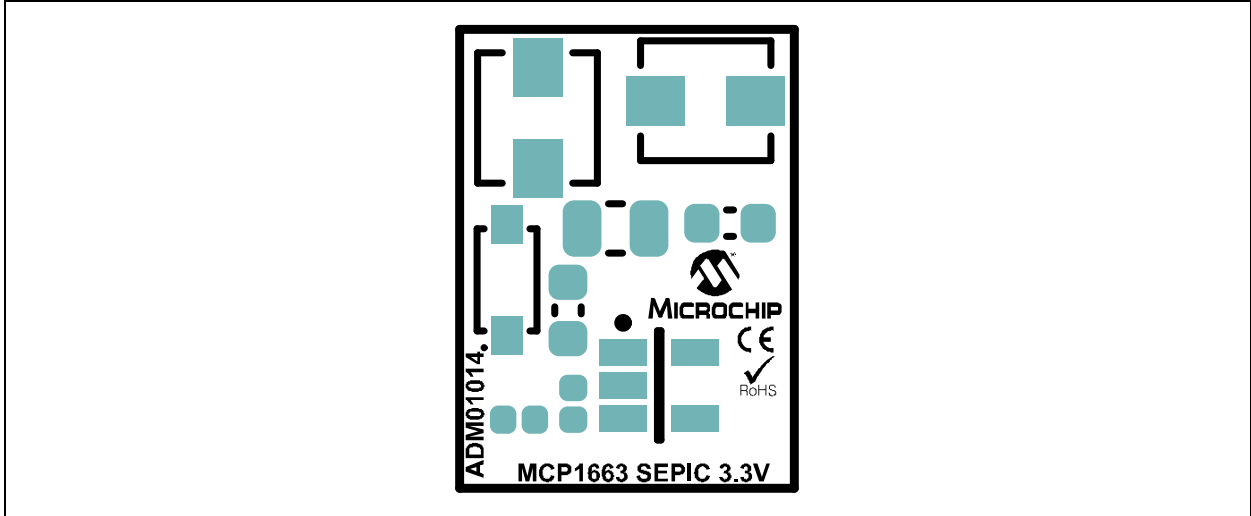

A.4 BOARD – TOP COPPER AND SILK

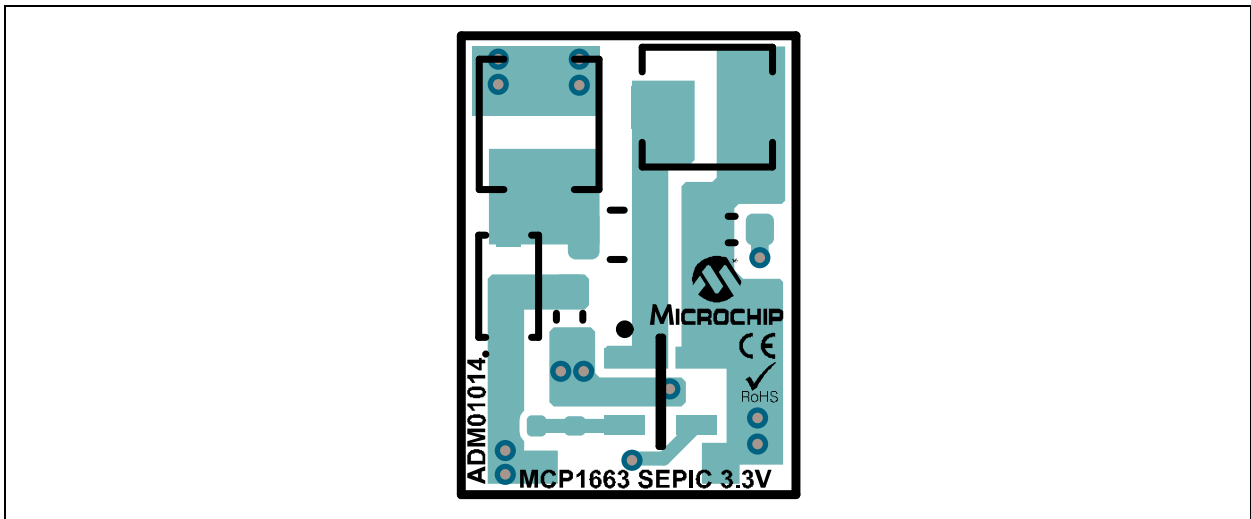

A.5 BOARD – TOP COPPER

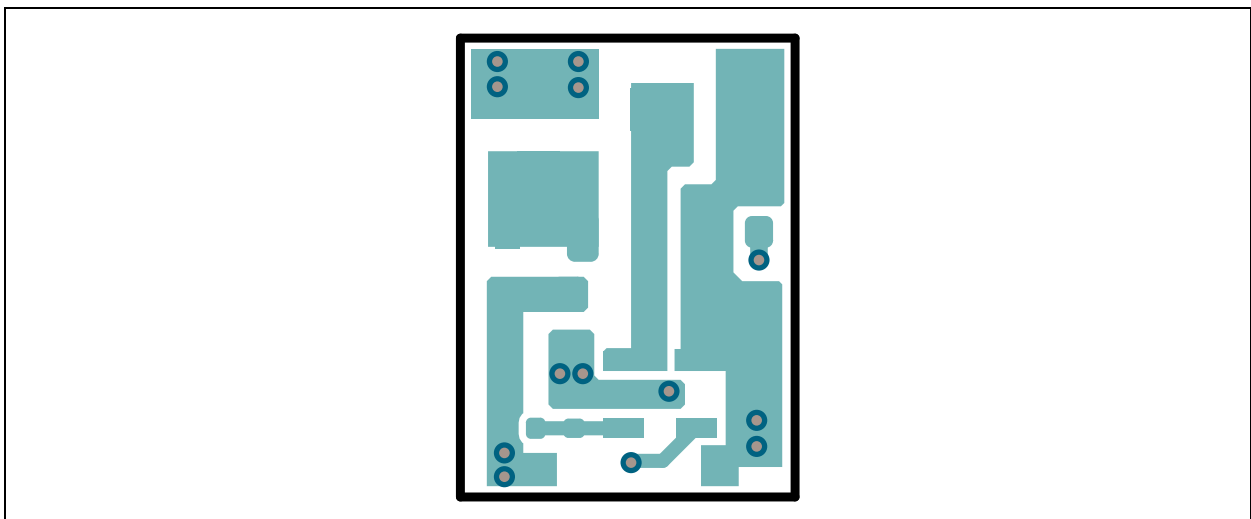

A.6 BOARD – BOTTOM COPPER

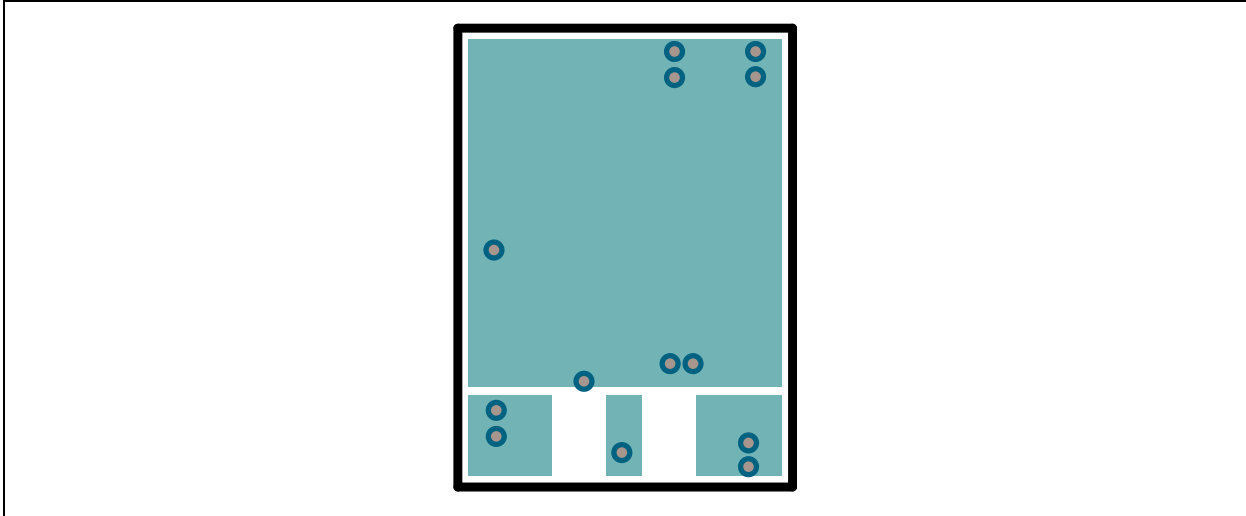

A.7 BOARD – BOTTOM COPPER AND SILK

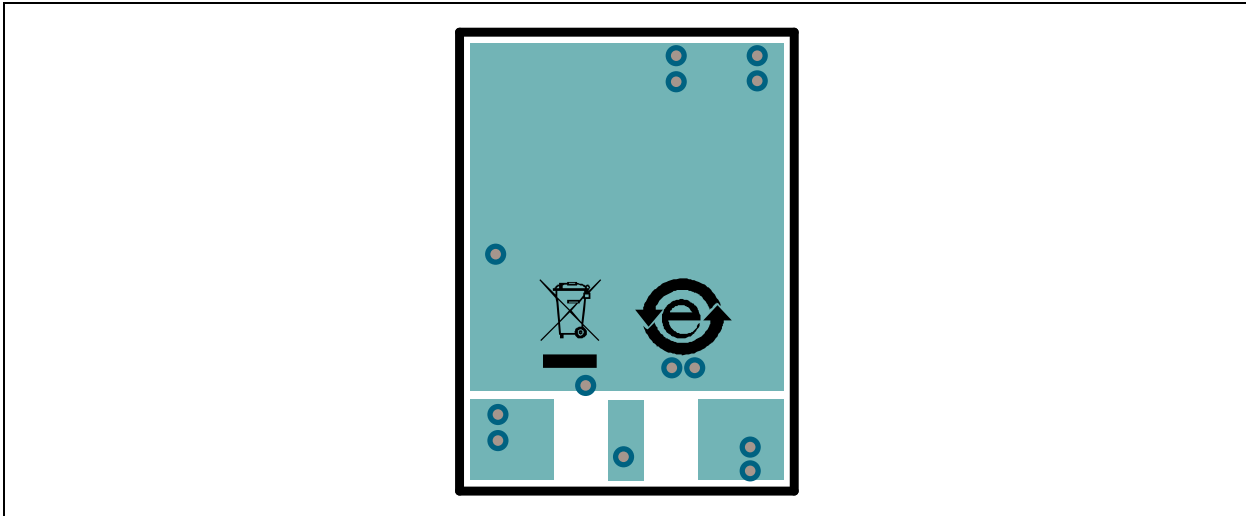

A.8 BOARD – BOTTOM SILK

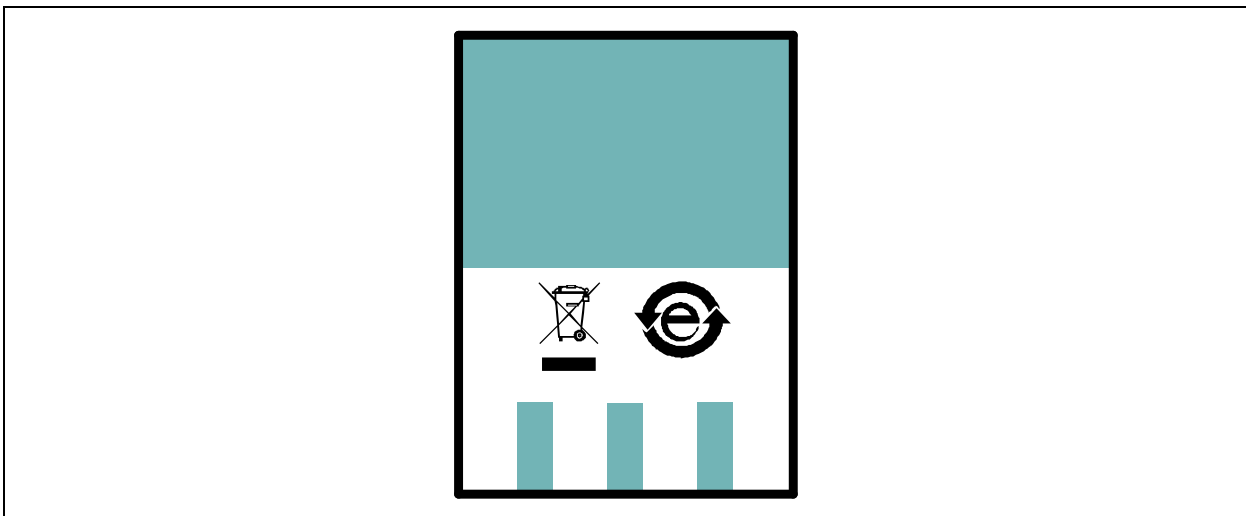



MCP1663 MINI-MODULE SEPIC CONVERTER EVALUATION BOARD USER'S

Appendix B. Bill of Materials (BOM)

TABLE B-1: BILL OF MATERIALS (BOM)

Qty.	Reference	Description	Manufacturer	Part Number
2	C1, C2	Capacitor Ceramic, 10 μ F, 10V, 20%, X5R, SMD, 0603	Samsung	CL10A106MP8NNNC
1	CC	Capacitor Ceramic, 4.7 μ F, 10V, 20%, Y5V, SMD, 0805	Samsung Elec- tro-Mechanics America, Inc	CL21F475ZPFNNNE
1	D1	Diode Schottky, RB161MM-20TR, 350mV, 1A, 20V, SMD, SOD-123F	ROHM Semiconductor	RB161MM-20TR
2	L1, L2	Inductor Fixed, 5.6 μ H, 2.2A, 238 mOHM, SMD, AEC-Q200	Bourns [®] , Inc.	SRP3020TA-5R6M
1	PCB1	Printed Circuit Board	Microchip Technology Inc.	04-10931-R1
1	RB	Resistor, TKF, 1.3k, 1%, 1/10W, SMD, 0402	Panasonic [®] - ECG	ERJ-2RKF1301X
1	RT	Resistor, TKF, 2.2k, 1%, 1/10W, SMD, 0402	Panasonic [®] - ECG	ERJ-2RKF2201X
1	U1	Microchip Analog Switcher Boost 32V MCP1663T-E/OT SOT-23-5	Microchip Technology Inc.	MCP1663T-E/OT

Note 1: The components listed in this Bill of Materials are representative of the PCB assembly. The released BOM used in manufacturing uses all RoHS-compliant components.