

FEATURES

- Powered from 3.15 V to 26 V
- Precision current sense amplifier
- Precision voltage input
- 12-bit ADC for current and voltage readback
- Convert (CONV) pin for commanding an ADC read
- SETV input for setting overcurrent alert threshold
- ALERTB output provides an overcurrent interrupt
- I²C fast mode-compliant interface (400 kHz maximum)
- 2 address pins allow 16 devices on the same bus
- 10-lead MSOP

APPLICATIONS

- Power monitoring/power budgeting
- Central office equipment
- Telecommunications and data communications equipment
- PCs/servers

GENERAL DESCRIPTION

The ADM1191 is an integrated current sense amplifier that offers digital current and voltage monitoring via an on-chip 12-bit analog-to-digital converter (ADC), communicated through an I²C[®] interface.

An internal current sense amplifier measures voltage across the sense resistor in the power path via the VCC pin and the SENSE pin.

A 12-bit ADC can measure the current seen in the sense resistor, as well as the supply voltage on the VCC pin.

An industry-standard I²C interface allows a controller to read current and voltage data from the ADC. Measurements can be initiated by an I²C command or via the convert (CONV) pin. The CONV pin is especially useful for synchronizing reads on multiple ADM1191 devices. Alternatively, the ADC can run continuously, and the user can read the latest conversion data whenever it is required. Up to 16 unique I²C addresses can be created, depending on the way the A0 pin and the A1 pin are connected.

A SETV pin is also included. A voltage applied to this pin is internally compared with the output voltage on the current sense amplifier. The output of the SETV comparator asserts when the current sense amplifier output exceeds the SETV voltage. When this event occurs, the ALERTB output asserts.

FUNCTIONAL BLOCK DIAGRAM

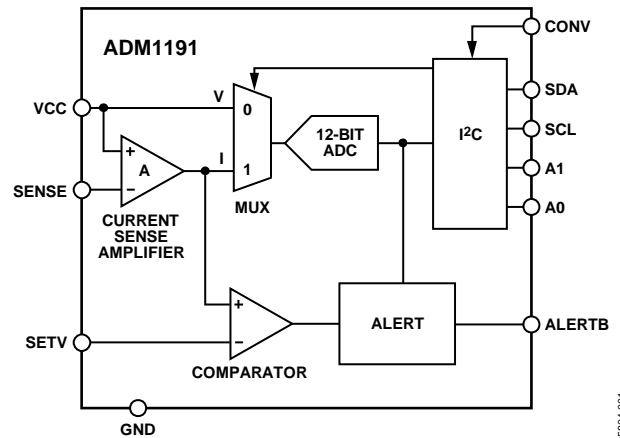

Figure 1.

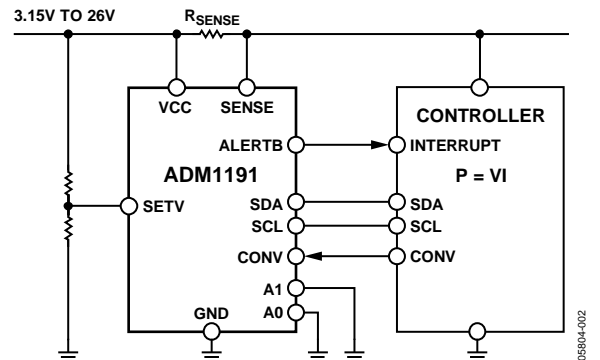

Figure 2. Applications Diagram

The ALERTB output can be used as a flag to warn a microcontroller or field programmable gate array (FPGA) of an overcurrent condition. ALERTB outputs of multiple ADM1191 devices can be tied together and used as a combined alert.

The ADM1191 is packaged in a 10-lead MSOP.

Rev. C

Information furnished by Analog Devices is believed to be accurate and reliable. However, no responsibility is assumed by Analog Devices for its use, nor for any infringements of patents or other rights of third parties that may result from its use. Specifications subject to change without notice. No license is granted by implication or otherwise under any patent or patent rights of Analog Devices. Trademarks and registered trademarks are the property of their respective owners.

TABLE OF CONTENTS

Features	1	Identifying the ADM1191 on the I ² C Bus.....	9
Applications.....	1	General I ² C Timing.....	9
General Description	1	Write and Read Operations.....	11
Functional Block Diagram	1	Quick Command.....	11
Revision History	2	Write Command Byte	11
Specifications.....	3	Write Extended Command Byte	12
Absolute Maximum Ratings.....	5	Read Voltage and/or Current Data Bytes.....	13
Thermal Characteristics	5	Applications Information	15
ESD Caution.....	5	ALERTB Output	15
Pin Configuration and Function Descriptions.....	6	SETV Pin	15
Typical Performance Characteristics	7	Kelvin Sense Resistor Connection	15
Voltage and Current Readback	9	Outline Dimensions	16
Serial Bus Interface.....	9	Ordering Guide	16

REVISION HISTORY

6/12—Rev. B to Rev. C

Added $V_{BUS} = 3.0\text{ V to }5.5\text{ V}$ Condition to V_{IL} and V_{IH} , Table 1..	4
Changed SETV Pin Rating from 30 V to 6 V, Table 2	5
Changes to Pin 3, Pin 5, and Pin 10 Descriptions.....	6
Changes to Bit 2, Table 9.....	12
Changes to ALERTB Output Section.....	15
Changes to Kelvin Sense Resistor Connection Section	15
Deleted Figure 27.....	15
Updated Outline Dimensions	16

2/08—Rev. A to Rev. B

Changed V_{VCC} to V_{CC} Throughout	3
Added ADC Conversion Time Parameter	3
Changes to Input Current for 00 Decode, I_{ADRLow} , Parameter ...	4
Changes to Input Current for 11 Decode, $I_{ADRHigh}$, Parameter...	4
Added Endnote 2.....	4
Changes to Figure 6.....	7
Changes to Identifying the ADM1191 on the I ² C Bus Section.....	9
Changes to General I ² C Timing Section, Step 3.....	9
Changes to Table 5.....	9
Changes to Figure 16 and Figure 17.....	10
Changes to Quick Command Section	11
Changes to Figure 19.....	11
Changes to Table 7.....	11
Changes to Write Extended Command Byte Section.....	12
Changes to Figure 21	12
Changes to Table 9 and Table 11.....	12
Changes to Converting ADC Codes to Voltage and Current Readings Section.....	13
Changes to Figure 25.....	15
Change to SETV Pin Section	15

4/07—Rev. 0 to Rev. A

Changes to Table 1.....	3
Changes to Table 5.....	9
Changes to Figure 16 and Figure 17	10
Changes to Figure 21.....	12
Changes to Figure 23 and Figure 24	13
Added Applications Information Heading	15

9/06—Revision 0: Initial Version

SPECIFICATIONS

$V_{CC} = 3.15\text{ V to }26\text{ V}$, $T_A = -40^\circ\text{C to }+85^\circ\text{C}$, typical values at $T_A = 25^\circ\text{C}$, unless otherwise noted.

Table 1.

Parameter	Min	Typ	Max	Unit	Conditions
VCC PIN					
Operating Voltage Range, V_{CC}	3.15		26	V	VCC rising
Supply Current, I_{CC}		1.7	2	mA	
Undervoltage Lockout, V_{UVLO}		2.8		V	
Undervoltage Lockout Hysteresis, $V_{UVLOHYST}$		80		mV	
CONV PIN					
Input Current, I_{CONV}	-2		+2	μA	
Logic Low Threshold, V_{CONVL}			1.2	V	
Logic High Threshold, V_{CONVH}	1.4			V	
MONITORING ACCURACY¹					
Current Sense Absolute Accuracy					
0°C to +70°C	-1.45		+1.45	%	$V_{SENSE} = 75\text{ mV}$
	-1.8		+1.8	%	$V_{SENSE} = 50\text{ mV}$
	-2.8		+2.8	%	$V_{SENSE} = 25\text{ mV}$
	-5.7		+5.7	%	$V_{SENSE} = 12.5\text{ mV}$
0°C to +85°C	-1.5		+1.5	%	$V_{SENSE} = 75\text{ mV}$
	-1.8		+1.8	%	$V_{SENSE} = 50\text{ mV}$
	-2.95		+2.95	%	$V_{SENSE} = 25\text{ mV}$
	-6.1		+6.1	%	$V_{SENSE} = 12.5\text{ mV}$
-40°C to +85°C	-1.95		+1.95	%	$V_{SENSE} = 75\text{ mV}$
	-2.45		+2.45	%	$V_{SENSE} = 50\text{ mV}$
	-3.85		+3.85	%	$V_{SENSE} = 25\text{ mV}$
	-6.7		+6.7	%	$V_{SENSE} = 12.5\text{ mV}$
V_{SENSE} for ADC Full Scale ²		105.84		mV	
Voltage Sense Accuracy					
0°C to +70°C	-0.85		+0.85	%	$V_{CC} = 3.0\text{ V to }5.5\text{ V}$ (low range)
	-0.9		+0.9	%	$V_{CC} = 10.8\text{ V to }16.5\text{ V}$ (high range)
0°C to +85°C	-0.85		+0.85	%	$V_{CC} = 3.0\text{ V to }5.5\text{ V}$ (low range)
	-0.9		+0.9	%	$V_{CC} = 10.8\text{ V to }16.5\text{ V}$ (high range)
-40°C to +85°C	-0.9		+0.9	%	$V_{CC} = 3.0\text{ V to }5.5\text{ V}$ (low range)
	-1.15		+1.15	%	$V_{CC} = 10.8\text{ V to }16.5\text{ V}$ (high range)
V_{CC} for ADC Full Scale ³					
Low Range (VRANGE = 1)		6.65		V	
High Range (VRANGE = 0)		26.52		V	
ADC Conversion Time ⁴					
		150		μs	
SENSE PIN					
Input Current, I_{SENSE}	-1		+1	μA	$V_{SENSE} = V_{CC}$
SETV PIN					
Overcurrent Trip Threshold					
	98	100	102	mV	$V_{SETV} = 1.8\text{ V}$
	49.5	50	50.5	mV	$V_{SETV} = 0.9\text{ V}$
Overcurrent Trip Gain, $V_{SETV}/(V_{CC} - V_{SENSE})$		18			$V_{SETV} = 0.9\text{ V to }1.9\text{ V}$
Input Current, $I_{SETVLEAK}$	-1		+1	μA	$V_{SETV} = 0.9\text{ V to }1.9\text{ V}$
ALERTB PIN					
Output Low Voltage, $V_{ALERTOL}$					
		0.05	0.1	V	$I_{ALERT} = -100\text{ }\mu\text{A}$
		1	1.5	mA	$I_{ALERT} = -2\text{ mA}$
Input Current, I_{ALERT}	-1		+1	μA	$V_{ALERT} = V_{CC}$; ALERTB not asserted

Parameter	Min	Typ	Max	Unit	Conditions
A0 PIN, A1 PIN					
Set Address to 00, $V_{ADRLOWV}$	0		0.8	V	Low state
Set Address to 01, $R_{ADRLOWZ}$	80	120	160	k Ω	Resistor to ground state, load pin with specified resistance for 01 decode
Set Address to 10, $I_{ADRHIGHZ}$	-0.3		+0.3	μ A	Open state, maximum load allowed on the A0 pin or A1 pin for 10 decode
Set Address to 11, $V_{ADRHIGHV}$	2		5.5	V	High state
Input Current for 00 Decode, I_{ADRLOW}	-40	-25		μ A	$V_{ADR} = 0V$ to 0.8V
Input Current for 11 Decode, $I_{ADRHIGH}$		3	6	μ A	$V_{ADR} = 2.0V$ to 5.5V
I ² C TIMING					
Low Level Input Voltage, V_{IL}			0.3 V_{BUS}	V	$V_{BUS} = 3.0V$ to 5.5V
High Level Input Voltage, V_{IH}	0.7 V_{BUS}			V	$V_{BUS} = 3.0V$ to 5.5V
Low Level Output Voltage on SDA, V_{OL}			0.4	V	$I_{OL} = 3$ mA
Output Fall Time on SDA from V_{IHMIN} to V_{ILMAX}	20 + 0.1 C_{BUS}		250	ns	C_{BUS} = bus capacitance from SDA to GND
Maximum Width of Spikes Suppressed by Input Filtering on SDA and SCL Pins	50		250	ns	
Input Current, I_I , on SDA/SCL When Not Driving a Logic Low Output	-10		+10	μ A	
Input Capacitance on SDA/SCL		5		pF	
SCL Clock Frequency, f_{SCL}			400	kHz	
Low Period of the SCL Clock	600			ns	
High Period of the SCL Clock	1300			ns	
Setup Time for Repeated Start Condition, $t_{SU,STA}$	600			ns	
SDA Output Data Hold Time, $t_{HD,DAT}$	100		900	ns	
Setup Time for a Stop Condition, $t_{SU,STO}$	600			ns	
Bus Free Time Between a Stop and a Start Condition, t_{BUF}	1300			ns	
Capacitive Load for Each Bus Line			400	pF	

¹ Monitoring accuracy is a measure of the error in a code that is read back for a particular voltage/current. This is a combination of amplifier error, reference error, ADC error, and error in ADC full-scale code conversion factor.

² This is an absolute value to be used when converting ADC codes to current readings; any inaccuracy in this value is factored into absolute current accuracy values (see the specifications for the Current Sense Absolute Accuracy parameter).

³ These are absolute values to be used when converting ADC codes to voltage readings; any inaccuracy in these values is factored into voltage accuracy values (see the specifications for the Voltage Sense Accuracy parameter).

⁴ Time between the receipt of the command byte and the actual ADC result being placed in the register.

ABSOLUTE MAXIMUM RATINGS

Table 2.

Parameter	Rating
VCC Pin	30 V
SENSE Pin	30 V
CONV Pin	-0.3 V to +6 V
SETV Pin	6 V
ALERTB Pin	30 V
SDA Pin, SCL Pin	-0.3 V to +6 V
A0 Pin, A1 Pin	-0.3 V to +6 V
Storage Temperature Range	-65°C to +125°C
Operating Temperature Range	-40°C to +85°C
Lead Temperature (Soldering, 10 sec)	300°C
Junction Temperature	150°C

Stresses above those listed under Absolute Maximum Ratings may cause permanent damage to the device. This is a stress rating only; functional operation of the device at these or any other conditions above those indicated in the operational section of this specification is not implied. Exposure to absolute maximum rating conditions for extended periods may affect device reliability.

THERMAL CHARACTERISTICS

θ_{JA} is specified for the worst-case conditions, that is, a device soldered in a circuit board for surface-mount packages.

Table 3. Thermal Resistance

Package Type	θ_{JA}	Unit
10-Lead MSOP	137.5	°C/W

ESD CAUTION



ESD (electrostatic discharge) sensitive device. Charged devices and circuit boards can discharge without detection. Although this product features patented or proprietary protection circuitry, damage may occur on devices subjected to high energy ESD. Therefore, proper ESD precautions should be taken to avoid performance degradation or loss of functionality.

PIN CONFIGURATION AND FUNCTION DESCRIPTIONS

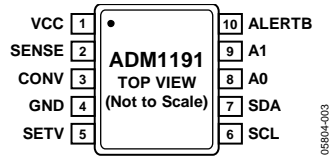

Figure 3. Pin Configuration

Table 4. Pin Function Descriptions

Pin No.	Mnemonic	Description
1	VCC	Positive Supply Input Pin. The operating supply voltage range is from 3.15 V to 26 V. An undervoltage lockout (UVLO) circuit resets the ADM1191 when a low supply voltage is detected.
2	SENSE	Current Sense Input Pin. A sense resistor between the VCC pin and the SENSE pin generates a voltage across a sense resistor. This voltage is proportional to the load current. A current sense amplifier amplifies this voltage before it is digitized by the ADC.
3	CONV	Convert Start Pin. A high level on this pin enables an ADC conversion. The state of an internal control register, which is set through the I ² C interface, configures the part to convert current only, voltage only, or both channels when the convert pin is asserted. If not required, this pin should be tied high to allow ADC to run.
4	GND	Chip Ground Pin.
5	SETV	Input Pin. The voltage driven onto this pin is compared with the output of the internal current sense amplifier. The lower the voltage on the SETV, the lower the current level that causes the ALERTB output to assert. Typical response time is 1 μ s to 2 μ s.
6	SCL	I ² C Clock Pin. Open-drain input; requires an external resistive pull-up.
7	SDA	I ² C Data I/O Pin. Open-drain input/output; requires an external resistive pull-up.
8	A0	I ² C Address Pin. This pin can be tied low, tied high, left floating, or tied low through a resistor. Sixteen I ² C address options are available, depending on the external configuration of the A0 pin and the A1 pin.
9	A1	I ² C Address Pin. This pin can be tied low, tied high, left floating, or tied low through a resistor. Sixteen I ² C address options are available, depending on the external configuration of the A0 pin and the A1 pin.
10	ALERTB	Alert Output Pin. Active low, open-drain configuration. This pin asserts low when an overcurrent condition is present. The level at which an overcurrent condition is detected depends on either the voltage on the SETV pin or the value in the ALERT_TH register. The ALERT_EN register will determine which is used in the comparison. This pin has a latching function and should be cleared manually using the ALERT_EN register.

TYPICAL PERFORMANCE CHARACTERISTICS

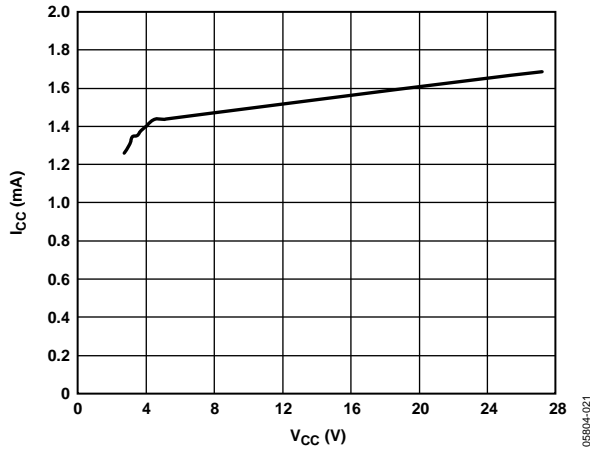

Figure 4. Supply Current vs. Supply Voltage

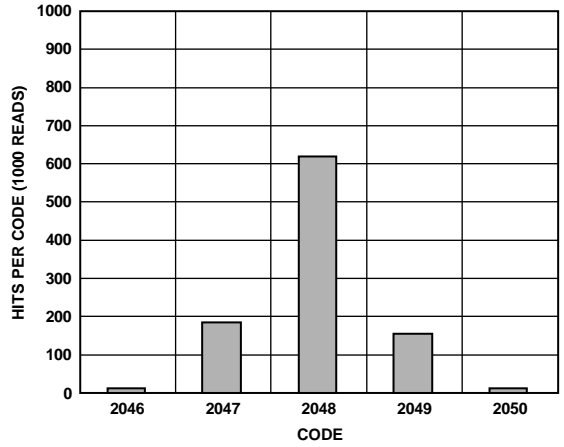

Figure 7. ADC Noise with Current Channel, Midcode Input, and 1000 Reads

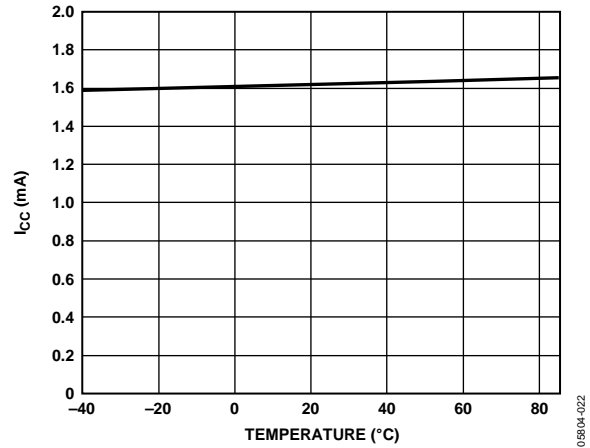

Figure 5. Supply Current vs. Temperature

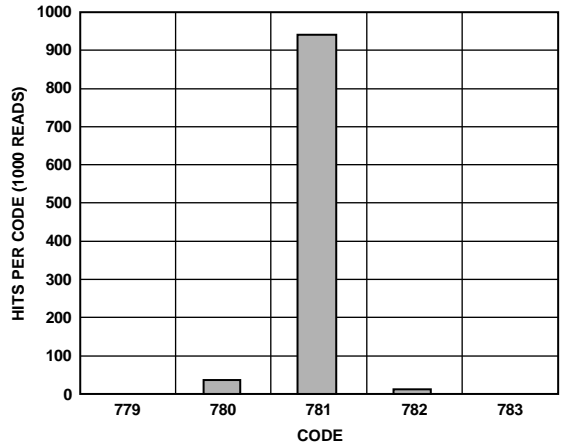

Figure 8. ADC Noise with 14:1 Voltage Channel, 5 V Input, and 1000 Reads

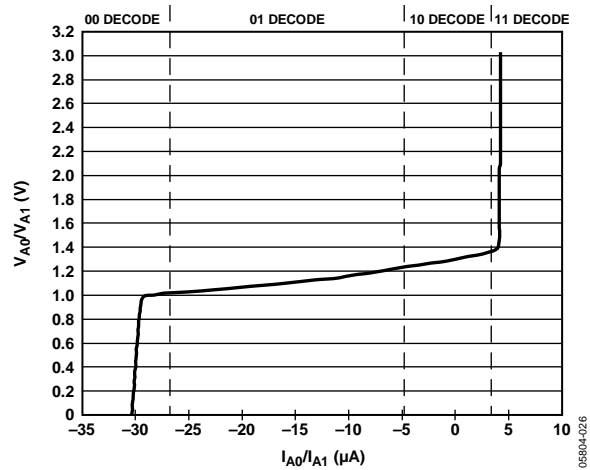

Figure 6. Address Pin Voltage vs. Address Pin Current for Four Addressing Options on Each Address Pin

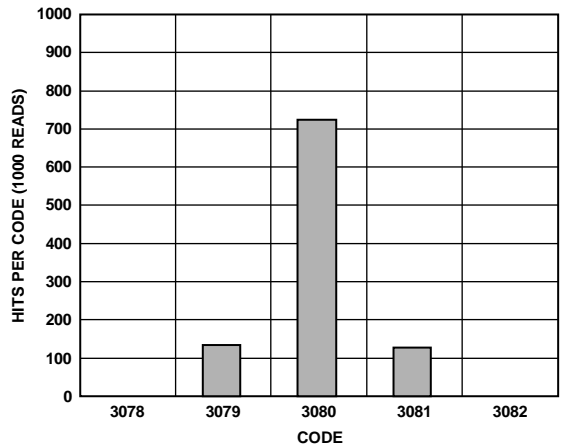

Figure 9. ADC Noise with 7:1 Voltage Channel, 5 V Input, and 1000 Reads

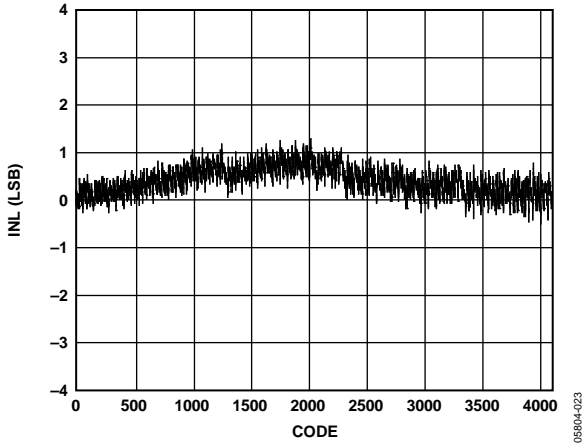

Figure 10. INL for ADC

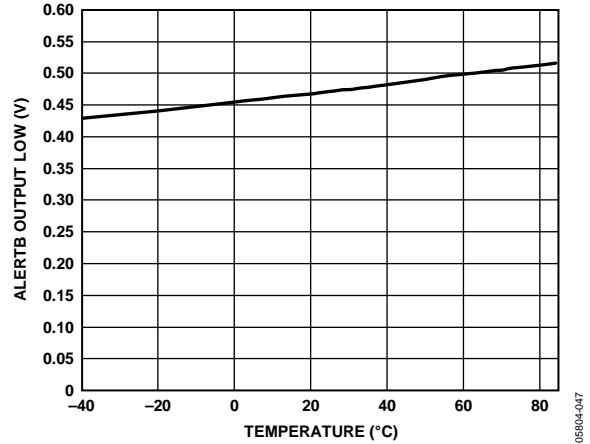

Figure 13. ALERTB Output Low Voltage vs. Temperature @ 1 mA

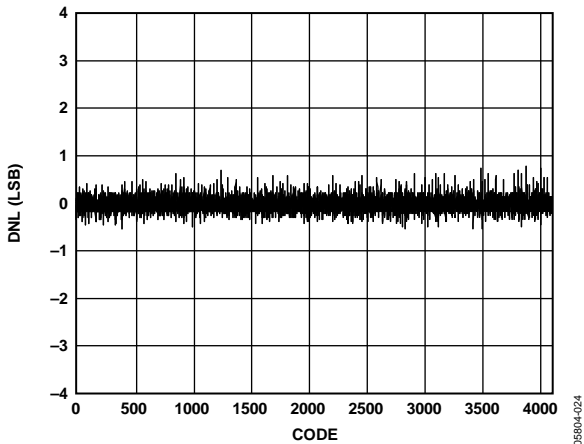

Figure 11. DNL for ADC

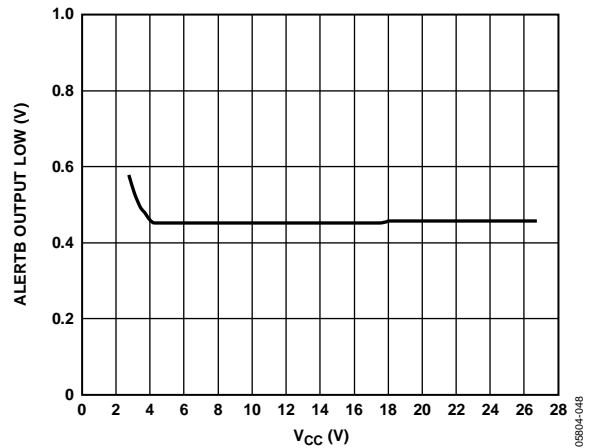

Figure 14. ALERTB Output Low Voltage vs. Supply Voltage @ 1 mA

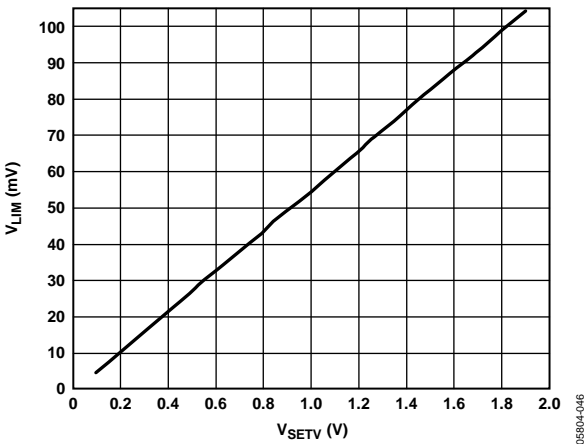

Figure 12. Overcurrent Limit Threshold vs. SETV Pin Voltage

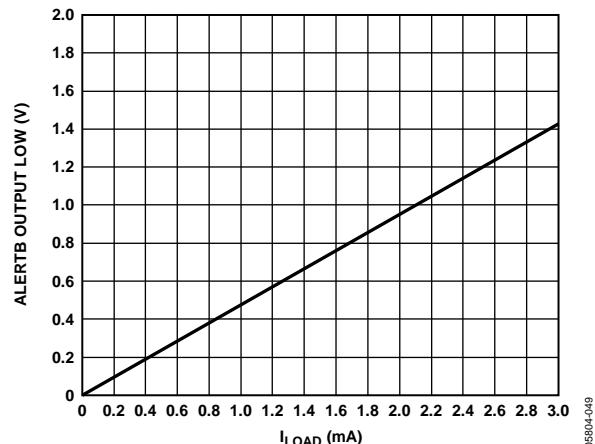

Figure 15. ALERTB Output Low Voltage vs. Load Current

VOLTAGE AND CURRENT READBACK

The ADM1191 contains the components to allow voltage and current readback over an I²C bus. The voltage output of the current sense amplifier and the voltage on the VCC pin are fed into a 12-bit ADC via a multiplexer. The device can be instructed to convert voltage and/or current at any time during operation by issuing an I²C command or driving the CONV pin high. When all conversions are complete, the voltage and/or current values can be read back with 12-bit accuracy in two or three bytes.

SERIAL BUS INTERFACE

Control of the ADM1191 is carried out via the serial system management bus (I²C). This interface is compatible with the I²C fast mode (400 kHz maximum). The ADM1191 is connected to this bus as a slave device, under the control of a master device.

IDENTIFYING THE ADM1191 ON THE I²C BUS

The ADM1191 has a 7-bit serial bus slave address. When the device powers up, it does so with a default serial bus address. The three MSBs of the address are set to 011; the four LSBs are determined by the state of the A0 pin and the A1 pin. There are 16 configurations available on the A0 pin and A1 pin that correspond to 16 I²C addresses for the four LSBs (see Table 5). This scheme allows 16 ADM1191 devices to operate on a single I²C bus.

GENERAL I²C TIMING

Figure 16 and Figure 17 show timing diagrams for general write and read operations using the I²C. The I²C specification defines conditions for different types of read and write operations, which are discussed in the Write and Read Operations section. The general I²C protocol operates as follows:

1. The master initiates a data transfer by establishing a start condition, defined as a high-to-low transition on the serial data line, SDA, while the serial clock line, SCL, remains high. This indicates that a data stream is to follow. All slave peripherals connected to the serial bus respond to the start condition and shift in the next eight bits, consisting of a 7-bit slave address (MSB first) plus an R/W bit that determines the direction of the data transfer, that is, whether data is written to or read from the slave device (0 = write, 1 = read).
2. Data is sent over the serial bus in sequences of nine clock pulses: eight bits of data followed by an acknowledge bit from the slave device. Data transitions on the data line must occur during the low period of the clock signal and remain stable during the high period because a low-to-high transition when the clock is high can be interpreted as a stop signal.

If the operation is a write operation, the first data byte after the slave address is a command byte. This tells the slave device what to expect next. It can be an instruction, such as telling the slave device to expect a block write, or it can be a register address that tells the slave where subsequent data is to be written.
3. Because data can flow in only one direction, as defined by the R/W bit, it is not possible to send a command to a slave device during a read operation. Before performing a read operation, it may be necessary to first execute a write operation to tell the slave what sort of read operation to expect and/or the address from which data is to be read.

2. Data is sent over the serial bus in sequences of nine clock pulses: eight bits of data followed by an acknowledge bit from the slave device. Data transitions on the data line must occur during the low period of the clock signal and remain stable during the high period because a low-to-high transition when the clock is high can be interpreted as a stop signal.

If the operation is a write operation, the first data byte after the slave address is a command byte. This tells the slave device what to expect next. It can be an instruction, such as telling the slave device to expect a block write, or it can be a register address that tells the slave where subsequent data is to be written.

Because data can flow in only one direction, as defined by the R/W bit, it is not possible to send a command to a slave device during a read operation. Before performing a read operation, it may be necessary to first execute a write operation to tell the slave what sort of read operation to expect and/or the address from which data is to be read.

3. When all data bytes are read or written, stop conditions are established. In write mode, the master pulls the data line high during the 10th clock pulse to assert a stop condition. In read mode, the master device releases the SDA line during the SCL low period before the ninth clock pulse, but the slave device does not pull it low. This is known as a no acknowledge. The master then takes the data line low during the SCL low period before the 10th clock pulse and then high during the 10th clock pulse to assert a stop condition.

Table 5. Setting I²C Addresses via the A0 Pin and the A1 Pin

Base Address	A1 Pin State	A0 Pin State	A1 Pin Logic State	A0 Pin Logic State	Address in Binary ¹	Address in Hex
011	Ground	Ground	00	00	0110000X	0x60
	Ground	Resistor to ground	00	01	0110001X	0x62
	Ground	Floating	00	10	0110010X	0x64
	Ground	High	00	11	0110011X	0x66
	Resistor to ground	Ground	01	00	0110100X	0x68
	Resistor to ground	Resistor to ground	01	01	0110101X	0x6A
	Resistor to ground	Floating	01	10	0110110X	0x6C
	Resistor to ground	High	01	11	0110111X	0x6E
	Floating	Ground	10	00	0111000X	0x70
	Floating	Resistor to ground	10	01	0111001X	0x72

Base Address	A1 Pin State	A0 Pin State	A1 Pin Logic State	A0 Pin Logic State	Address in Binary ¹	Address in Hex
	Floating	Floating	10	10	0111010X	0x74
	Floating	High	10	11	0111011X	0x76
	High	Ground	11	00	0111100X	0x78
	High	Resistor to ground	11	01	0111101X	0x7A
	High	Floating	11	10	0111110X	0x7C
	High	High	11	11	0111111X	0x7E

¹X = don't care.

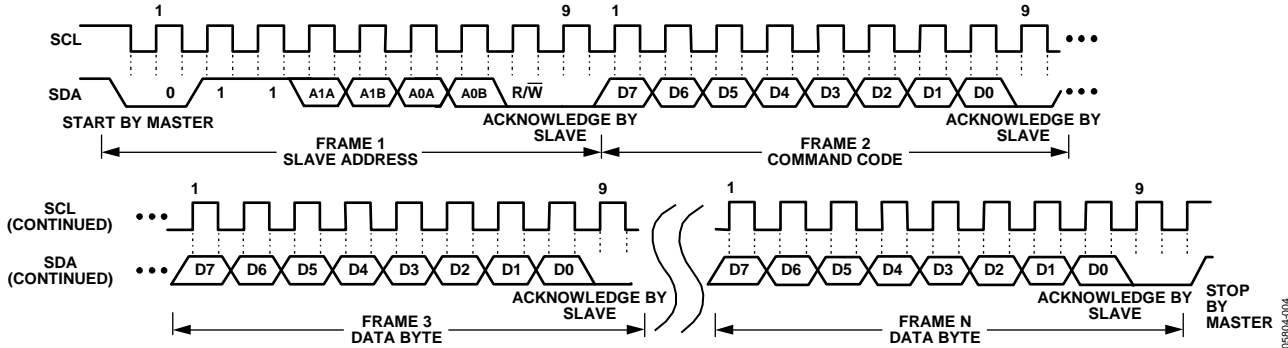

Figure 16. General I2C Write Timing Diagram

05904-004

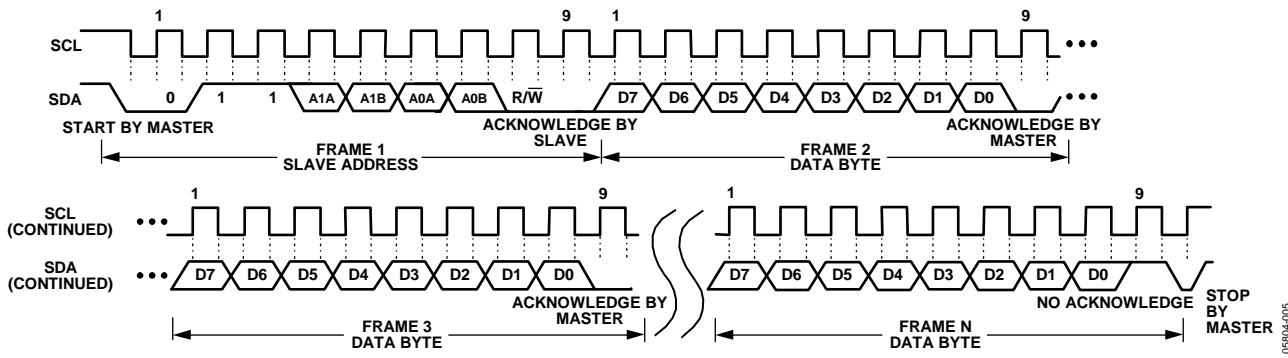

Figure 17. General I2C Read Timing Diagram

05904-005

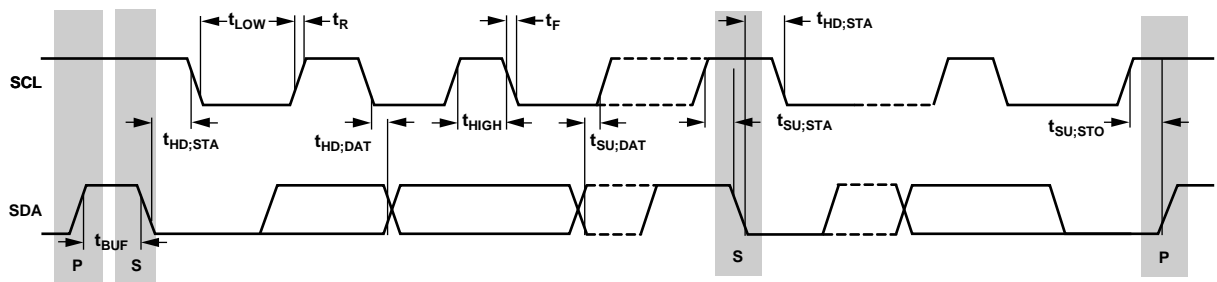

Figure 18. Serial Bus Timing Diagram

05904-006

WRITE AND READ OPERATIONS

The I²C specification defines several protocols for different types of read and write operations. The operations used in the ADM1191 are discussed in this section. Table 6 shows the abbreviations used in the command diagrams (see Figure 19 to Figure 24).

Table 6. I²C Abbreviations

Abbreviation	Condition
S	Start
P	Stop
R	Read
W	Write
A	Acknowledge
N	No acknowledge

QUICK COMMAND

The quick command operation allows the master to check if the slave is present on the bus, as follows:

1. The master device asserts a start condition on SDA.
2. The master sends the 7-bit slave address, followed by the write bit (low).
3. The addressed slave device asserts an acknowledge on SDA.
4. The master asserts a stop condition on SDA to end the transaction.

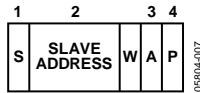

Figure 19. Quick Command

WRITE COMMAND BYTE

In the write command byte operation, the master device sends a command byte to the slave device, as follows:

1. The master device asserts a start condition on SDA.
2. The master sends the 7-bit slave address, followed by the write bit (low).
3. The addressed slave device asserts an acknowledge on SDA.
4. The master sends the command byte. The command byte is identified by an MSB = 0. An MSB = 1 indicates an extended register write (see the Write Extended Command Byte section).
5. The slave asserts an acknowledge on SDA.
6. The master asserts a stop condition on SDA to end the transaction.

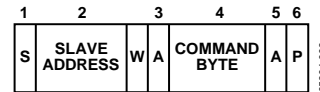

Figure 20. Write Command Byte

The seven LSBs of the command byte are used to configure and control the ADM1191. Table 7 provides details of the function of each bit.

Table 7. Command Byte Operations

Bit	Default	Name	Function
C0	0	V_CONT	LSB, set to convert voltage continuously. If readback is attempted before the first conversion is complete, the ADM1191 asserts an acknowledge and returns all 0s in the returned data.
C1	0	V_ONCE	Set to convert voltage once. Self-clears. I ² C asserts a no acknowledge on attempted reads until the ADC conversion is complete.
C2	0	I_CONT	Set to convert current continuously. If readback is attempted before the first conversion is complete, the ADM1191 asserts an acknowledge and returns all 0s in the returned data.
C3	0	I_ONCE	Set to convert current once. Self-clears. I ² C asserts a no acknowledge on attempted reads until the ADC conversion is complete.
C4	0	VRANGE	Selects different internal attenuation resistor networks for voltage readback. A 0 in C4 selects a 14:1 voltage divider. A 1 in C4 selects a 7:2 voltage divider. With an ADC full scale of 1.902 V, the voltage at the VCC pin for an ADC full-scale result is 26.52 V for VRANGE = 0 and 6.65 V for VRANGE = 1.
C5	0	N/A	Unused.
C6	0	STATUS_RD	Status Read. When this bit is set, the data byte read back from the ADM1191 is the status byte. It contains the status of the device alerts. See Table 15 for full details of the status byte.

WRITE EXTENDED COMMAND BYTE

In the write extended command byte operation, the master device writes to one of the three extended registers of the slave device, as follows:

1. The master device asserts a start condition on SDA.
2. The master sends the 7-bit slave address, followed by the write bit (low).
3. The addressed slave device asserts an acknowledge on SDA.
4. The master sends the register address byte. The MSB of this byte is set to 1 to indicate an extended register write. The two LSBs indicate which of the three extended registers is to be written to (see Table 8). All other bits should be set to 0.
5. The slave asserts an acknowledge on SDA.
6. The master sends the extended command byte (refer to Table 9, Table 10, and Table 11).

7. The slave asserts an acknowledge on SDA.
8. The master asserts a stop condition on SDA to end the transaction.

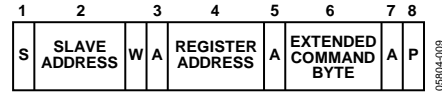

Figure 21. Write Extended Byte

Table 9, Table 10, and Table 11 provide the details of each extended register.

Table 8. Extended Register Addresses

A6	A5	A4	A3	A2	A1	A0	Extended Register
0	0	0	0	0	0	1	ALERT_EN
0	0	0	0	0	1	0	ALERT_TH
0	0	0	0	0	1	1	CONTROL

Table 9. ALERT_EN Register Operations

Bit	Default	Name	Function
0	0	EN_ADC_OC1	LSB, enabled if a single ADC conversion on the I channel exceeds the threshold set in the ALERT_TH register.
1	0	EN_ADC_OC4	Enabled if four consecutive ADC conversions on the I channel exceed the threshold set in the ALERT_TH register.
2	0	EN_OC_ALERT	Enables the OC_ALERT register. If an overcurrent condition is present compared to the SETV threshold, the OC_ALERT register captures and latches this condition.
3	0	EN_OFF_ALERT	Set this bit high to activate the SWOFF bit (see Table 11).
4	0	CLEAR	Clears the OFF_ALERT, OC_ALERT, and ADC_ALERT status bits in the status register. The value of these bits may immediately change if the source of the alert is not been cleared and the alert function is not disabled. The CLEAR bit self-clears to 0 after the STATUS register bits have been cleared.

Table 10. ALERT_TH Register Operations

Bit	Default	Function
7:0	FF	The ALERT_TH register sets the current level at which an alert occurs. Defaults to ADC full scale. The ALERT_TH 8-bit value corresponds to the top eight bits of the current channel data.

Table 11. CONTROL Register Operations

Bit	Default	Name	Function
0	0	SWOFF	LSB, forces the ALERTB pin to deassert. Can be active only if the EN_OFF_ALERT bit is high (see Table 9).

READ VOLTAGE AND/OR CURRENT DATA BYTES

Depending on how the device is configured, ADM1191 can be set up to provide information in three ways after a conversion (or conversions): voltage and current readback, voltage only readback, and current only readback. See the Write Command Byte section for more details.

Voltage and Current Readback

The ADM1191 digitizes both voltage and current. Three bytes are read back in the format shown in Table 12.

Table 12. Voltage and Current Readback

Byte	Contents	B7	B6	B5	B4	B3	B2	B1	B0
1	Voltage MSBs	V11	V10	V9	V8	V7	V6	V5	V4
2	Current MSBs	I11	I10	I9	I8	I7	I6	I5	I4
3	LSBs	V3	V2	V1	V0	I3	I2	I1	I0

Voltage Readback

The ADM1191 digitizes voltage only. Two bytes are read back in the format shown in Table 13.

Table 13. Voltage Only Readback Format

Byte	Contents	B7	B6	B5	B4	B3	B2	B1	B0
1	Voltage MSBs	V11	V10	V9	V8	V7	V6	V5	V4
2	Voltage LSBs	V3	V2	V1	V0	0	0	0	0

Current Readback

The ADM1191 digitizes current only. Two bytes are read back in the format shown in Table 14.

Table 14. Current Only Readback Format

Byte	Contents	B7	B6	B5	B4	B3	B2	B1	B0
1	Current MSBs	I11	I10	I9	I8	I7	I6	I5	I4
2	Current LSBs	I3	I2	I1	I0	0	0	0	0

The following series of events occurs when the master receives three bytes (voltage and current data) from the slave device:

1. The master device asserts a start condition on SDA.
2. The master sends the 7-bit slave address, followed by the read bit (high).
3. The addressed slave device asserts an acknowledge on SDA.
4. The master receives the first data byte.
5. The master asserts an acknowledge on SDA.
6. The master receives the second data byte.
7. The master asserts an acknowledge on SDA.
8. The master receives the third data byte.

9. The master asserts a no acknowledge on SDA.
10. The master asserts a stop condition on SDA, and the transaction ends.

For cases where the master is reading voltage only or current only, two data bytes are read and Step 7 and Step 8 are not required.

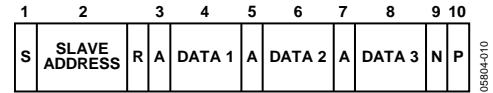

Figure 22. Three-Byte Read from ADM1191

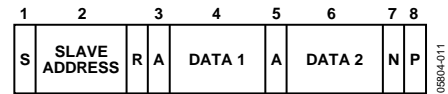

Figure 23. Two-Byte Read from ADM1191

Converting ADC Codes to Voltage and Current Readings

Equation 1 and Equation 2 can be used to convert ADC codes representing voltage and current from the ADM1191 12-bit ADC into actual voltage and current values.

$$Voltage = (V_{FULLSCALE}/4096) \times Code \tag{1}$$

where:

$$V_{FULLSCALE} = 6.65 \text{ V (7:2 range) or } 26.52 \text{ V (14:1 range).}$$

Code is the ADC voltage code read from the device (Bit V11 to Bit V0).

$$Current = ((I_{FULLSCALE}/4096) \times Code)/Sense \text{ Resistor} \tag{2}$$

where:

$$I_{FULLSCALE} = 105.84 \text{ mV.}$$

Code is the ADC current code read from the device (Bit I11 to Bit I0).

Read Status Register

A single register of status data can also be read from the ADM1191 as follows:

1. The master device asserts a start condition on SDA.
2. The master sends the 7-bit slave address, followed by the read bit (high).
3. The addressed slave device asserts an acknowledge on SDA.
4. The master receives the status byte.
5. The master asserts an acknowledge on SDA.

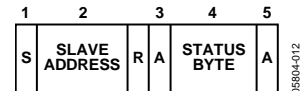

Figure 24. Status Read from ADM1191

Table 15 shows the ADM1191 STATUS registers in detail. Note that Bit 1, Bit 3, and Bit 5 are cleared by writing to Bit 4 (the CLEAR bit) of the ALERT_EN register.

Table 15. Status Byte Operations

Bit	Name	Function
0	ADC_OC	An ADC-based overcurrent comparison is detected on the last three conversions.
1	ADC_ALERT	An ADC-based overcurrent trip has occurred, causing the alert. Cleared by writing to Bit 4 of the ALERT_EN register.
2	OC	An overcurrent condition is present (that is, the output of the current sense amplifier is greater than the voltage on the SETV input).
3	OC_ALERT	An overcurrent condition causes the ALERT block to latch a fault, and the ALERTB output asserts. Cleared by writing to Bit 4 of the ALERT_EN register.
4	OFF_STATUS	Set to 1 by writing to the SWOFF bit of the CONTROL register.
5	OFF_ALERT	An alert has been caused by the SWOFF bit. Cleared by writing to Bit 4 of the ALERT_EN register.

APPLICATIONS INFORMATION

ALERTB OUTPUT

The ALERTB output is an open-drain pin with 30 V tolerance. This output can be used as an overcurrent flag by connecting it to the general-purpose logic input of a controller. During normal operation, this output is pulled high (an external pull-up resistor should be used because this is an open-drain pin). When an overcurrent condition occurs, the ADM1191 pulls this output low. The ALERTB pin is disabled by default on power up. See the ALERT_EN register to enable.

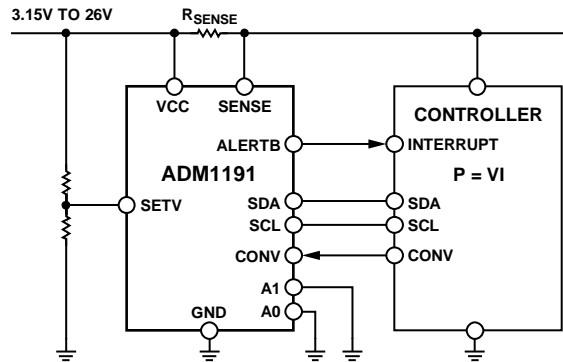

Figure 25. Using the ALERTB Output as an Interrupt

SETV PIN

The SETV pin allows the user to adjust the current level that trips the ALERTB output. The output of the current sense amplifier is compared with the voltage driven onto the SETV pin. If the current sense amplifier output is higher than the SETV voltage, the output of the comparator asserts. By driving a different voltage onto the SETV pin, the ADM1191 detects an overcurrent

condition at a different current level, with a gain of 18. See Figure 12 for an illustration of this relationship.

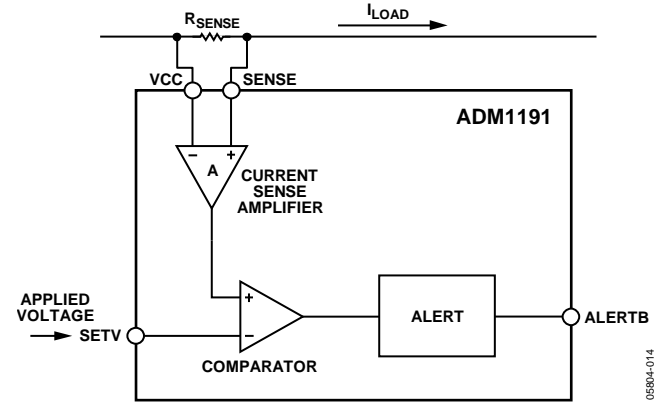

Figure 26. SETV Operation

KELVIN SENSE RESISTOR CONNECTION

When using a low value sense resistor for high current measurement, the problem of parasitic series resistance can arise. The pad and solder resistance can be a substantial fraction of the rated resistance, making the total resistance larger than expected. This error problem can be largely avoided by using a Kelvin sense connection. This type of connection separates the high current path through the resistor and the voltage drop across the resistor. A 4-pad resistor may be used or a split pad layout can be used with a 2-pad sense resistor to achieve Kelvin sensing.