

Daughter Card Evaluation Board for the **ADP1053** Digital Power Supply Controller

FEATURES

ADP1053 daughter card with 40-pin connector and I²C interface

Plugs into **ADP1053** evaluation motherboard

PMBus compliant

Low component count

PCB size: 28 mm × 50 mm

Robust design

GENERAL DESCRIPTION

The **ADP1053**, based on a voltage mode PWM architecture, is a flexible, application dedicated digital controller designed for isolated and nonisolated dc-to-dc power supply applications. The **ADP1053** enables highly efficient power supply design and facilitates the introduction of intelligent power management techniques to improve energy efficiency at a system level. The **ADP1053** operates from a single 3.3 V supply.

The **ADP1053** provides control, monitoring, and protection of up to three independent channel outputs. The eight flexible PWM outputs can be configured as three independent channels: two regulated channels with feedback control plus one additional unregulated channel with a fixed duty cycle. The frequency of these three channels can be programmed individually from 50 kHz to 625 kHz; all channels can be synchronized internally or to an external signal.

Features include differential voltage sensing, fast current sensing, flexible start-up sequencing and tracking, and synchronization between devices to reduce low frequency system noise. Protection and monitoring features include overcurrent protection (OCP), undervoltage protection (UVP), overvoltage protection (OVP), and overtemperature protection (OTP).

EVALUATION BOARD DESCRIPTION

The **ADP1053** daughter card evaluation board allows the user to quickly evaluate the **ADP1053** (see Figure 1). The **ADP1053** daughter card plugs into an existing **ADP1053** evaluation motherboard. Communication to the daughter card is established by connecting the USB-to-I²C dongle interface between the daughter card and a PC running Windows® 2000, Windows NT, Windows XP, Windows Vista®, or Windows 7.

The USB-to-I²C dongle interface (Part No. ADP-I2C-USB-Z) must be purchased separately from Analog Devices, Inc. The graphical user interface (GUI) software for the **ADP1053** daughter card evaluation board can be downloaded from the **ADP1053** product page.

This user guide describes how to set up and use the **ADP1053** daughter card evaluation board. The user guide should be read in conjunction with the **ADP1053** data sheet, which provides detailed information about the **ADP1053** 3-channel digital power supply controller.

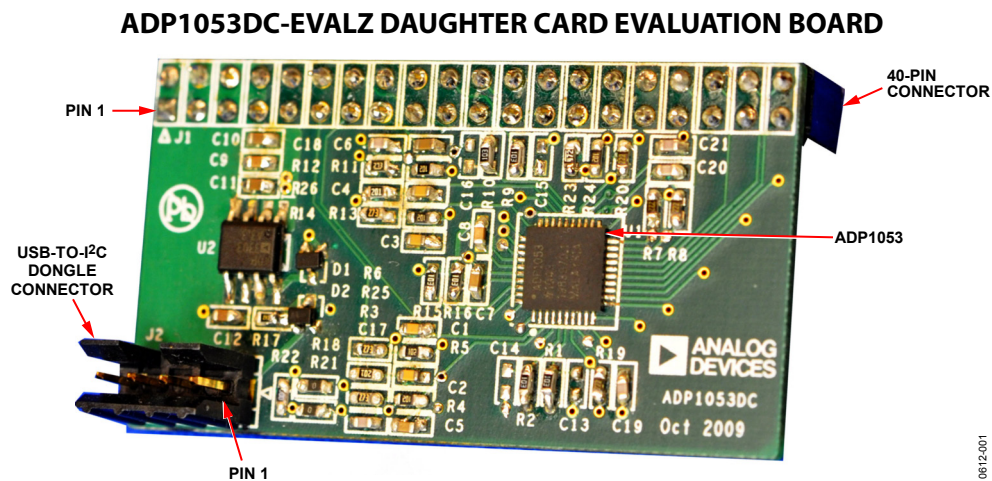

Figure 1.

10612-001

TABLE OF CONTENTS

Features	1	USB-to-I ² C Dongle	3
General Description	1	Operating Instructions for the Evaluation Board	4
Evaluation Board Description.....	1	Evaluation Board Schematic and Artwork.....	5
ADP1053DC-EVALZ Daughter Card Evaluation Board	1	Ordering Information	7
Revision History	2	Bill of Materials.....	7
Hardware Description.....	3	Related Links.....	7
40-Pin Connector	3		

REVISION HISTORY

5/12—Revision 0: Initial Version

HARDWARE DESCRIPTION

40-PIN CONNECTOR

The [ADP1053](#) daughter card PCB is 28 mm × 50 mm. A 40-pin connector is soldered to the back of the daughter card evaluation board (see Figure 2).

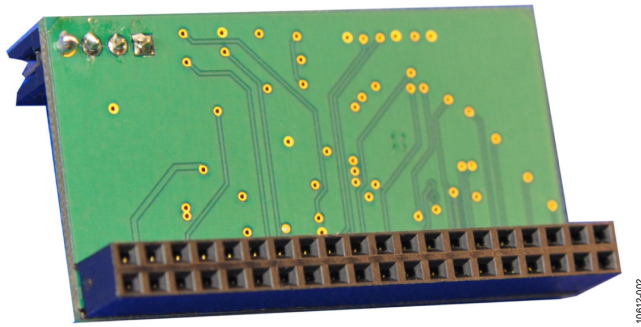

Figure 2. Backside of the Daughter Card

The 40-pin connector plugs directly into an existing [ADP1053](#) evaluation motherboard. A 5 V source from the USB connection provides power to the on-board [ADP3303](#) LDO, which, in turn, provides the 3.3 V power to the [ADP1053](#).

Figure 3 shows the pin assignments for the 40-pin connector on the [ADP1053](#) daughter card evaluation board.

TOP VIEW
(COMPONENT SIDE)

NC	1	40	NC
NC	2	39	AGND
12V_AUX	3	38	3.3V
FLAGOUT	4	37	FLAGIN
RTD1	5	36	RTD2
VS+_A	6	35	VS+_B
VS-_A	7	34	VS-_B
PGND_A	8	33	PGND_B
OVP_A	9	32	OVP_B
CS2-_A	10	31	CS2-_B
CS2+_A	11	30	CS2+_B
PGOOD_A	12	29	PGOOD_B
CS1_A	13	28	CS1_B
ACSNS	14	27	CS
PSON_A	15	26	PSON_B
SCL	16	25	SDA
OUT1	17	24	OUT8
OUT2	18	23	OUT7
OUT3	19	22	OUT6
OUT4	20	21	OUT5

Figure 3. 40-Pin Connector Pin Assignments

USB-TO-I²C DONGLE

For a complete evaluation of the [ADP1053](#), the following items are required:

- [ADP1053](#) evaluation motherboard
- [ADP1053](#) evaluation daughter card
- USB-to-I²C dongle interface
- Software GUI

Figure 4 shows how to use the USB-to-I²C dongle to connect the [ADP1053](#) daughter card to the PC.

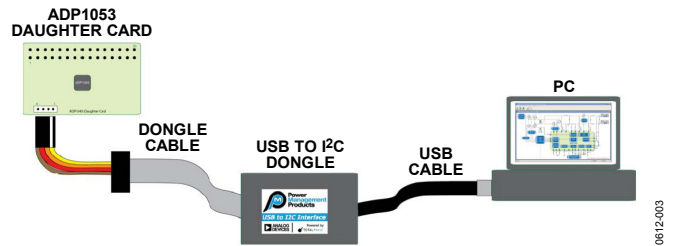

Figure 4. Connecting the [ADP1053](#) Daughter Card to a PC Using the USB-to-I²C Dongle

The USB-to-I²C dongle interface has four pins (see Table 1).

Table 1. I²C Connector Pin Assignment

Pin No.	Evaluation Board Function
1	5V
2	SCL (clock)
3	SDA (data)
4	Ground

OPERATING INSTRUCTIONS FOR THE EVALUATION BOARD

To use the [ADP1053](#) evaluation board, follow these steps:

1. Insert the ADP1053DC-EVALZ daughter card into the [ADP1053](#) evaluation motherboard (see Figure 5). Note that users must create a motherboard for the [ADP1053](#) evaluation daughter card (the motherboard shown in Figure 5 is a prototype).
2. Connect the cables of the USB-to-I²C dongle to the daughter card and to the PC (see Figure 4).

The USB interface provides the 5 V supply to the daughter card. The daughter card has an on-board LDO (the [ADP3303](#)) that provides the 3.3 V power to the [ADP1053](#).

3. Download the [ADP1053](#) GUI software from the [ADP1053 product page](#) and install the software on a PC.
4. Run the GUI software to verify the connection to the [ADP1053](#) before applying the input supply voltage to the motherboard.
5. Apply power to the input terminals of the motherboard.

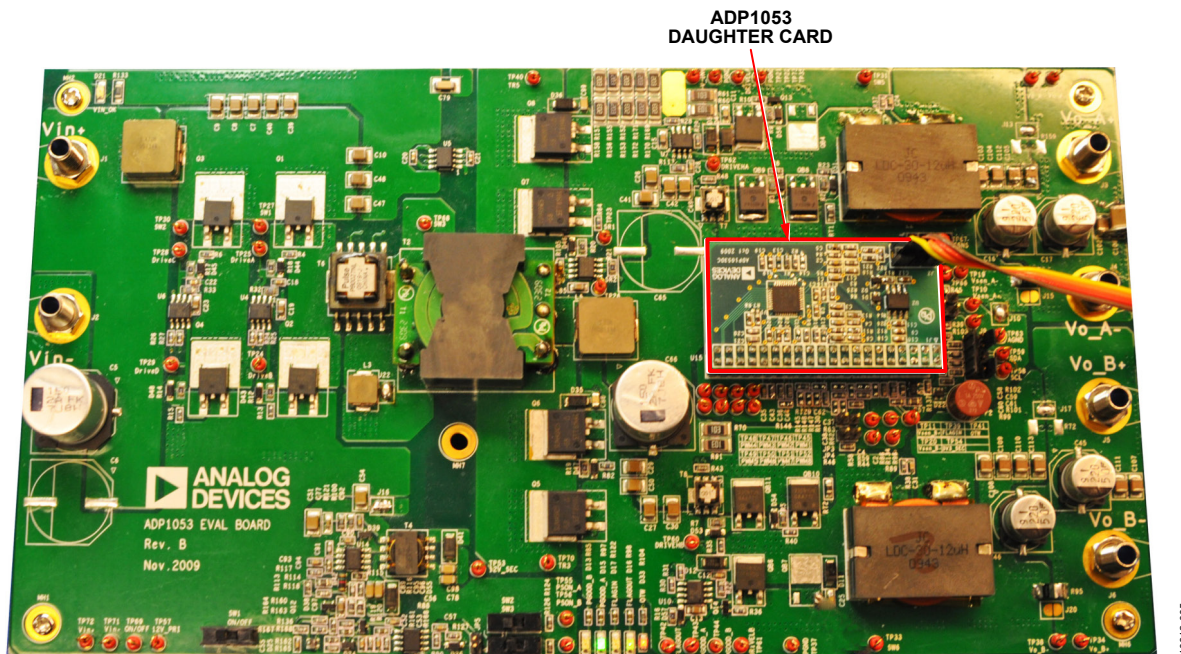

Figure 5. [ADP1053](#) Evaluation Board with Daughter Card Plugged In

EVALUATION BOARD SCHEMATIC AND ARTWORK

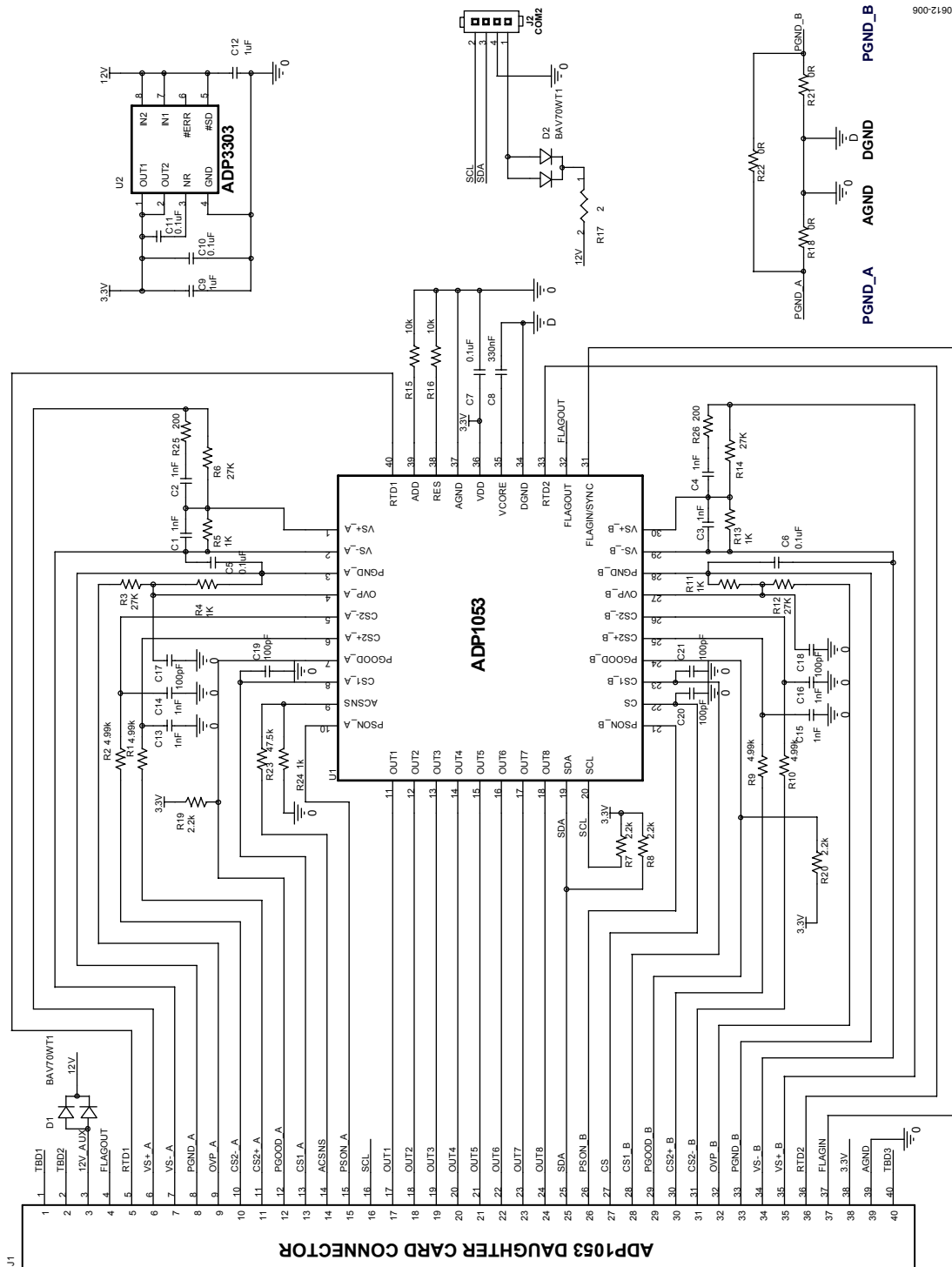

Figure 6. Schematic of the Evaluation Board

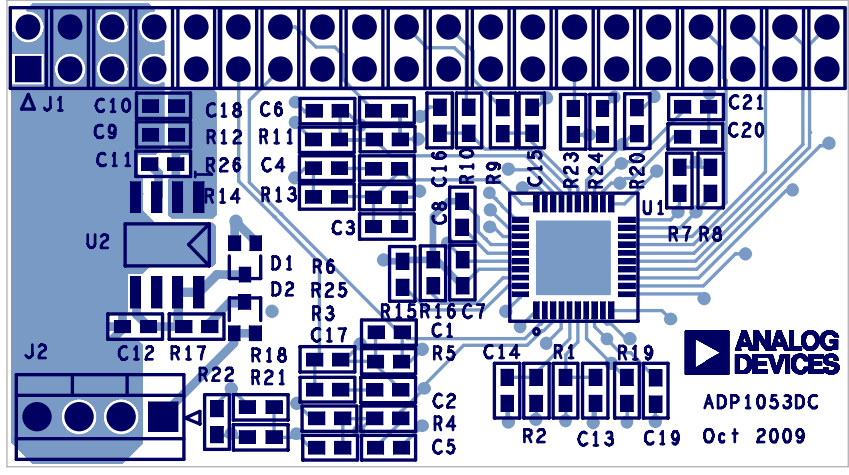

Figure 7. Top Layer and Silkscreen

ORDERING INFORMATION

BILL OF MATERIALS

Table 2.

Qty	Reference	Description	Vendor	Part No.
1	U1	ADP1053 (device under test), 40-lead LFCSP	Analog Devices	ADP1053ACPZ-R7
1	U2	ADP3303 low dropout linear regulator	Analog Devices	ADP3303ARZ-3.3
8	C1, C2, C3, C4, C13, C14, C15, C16	Capacitor, MLCC, 1 nF, 50 V, C0G, 0603	Digi-Key	C1608C0G1H102J
5	C5, C6, C7, C10, C11	Capacitor, MLCC, 0.1 μ F, 50 V, X7R, 0603	Digi-Key	C1608X7R1H104K
1	C8	Capacitor, MLCC, 330 nF, 50 V, X7R, 0603	Digi-Key	C1608X7R1H334K
2	C9, C12	Capacitor, MLCC, 1 μ F, 16 V, X7R, 0603	Digi-Key	C1608X7R1C105K
5	C17, C18, C19, C20, C21	Capacitor, MLCC, 100 pF, 50 V, C0G, 0603	Digi-Key	C1608C0G1H101J
2	D1, D2	Diode, 200 mA, 70 V	Digi-Key	BAV70WT1G
1	J1	40-pin connector	Digi-Key	PPTC202LFBN-RC
1	J2	Connector, header, 4-pin, single, PCB 30GOLD	Digi-Key	609-2411-ND
4	R1, R2, R9, R10	Resistor, 4.99 k Ω , 0.1%, 1/10 W, 0603	Digi-Key	TNPW06034K99BEEA
4	R3, R6, R12, R14	Resistor, 27 k Ω , 1%, 1/10 W, 0603	Digi-Key	ERJ-3EKF2702V
5	R4, R5, R11, R13, R24	Resistor, 1 k Ω , 1%, 1/10 W, 0603	Digi-Key	ERJ-3EKF1001V
4	R7, R8, R19, R20	Resistor, 2.2 k Ω , 1%, 1/10 W, 0603	Digi-Key	ERJ-3EKF2201V
2	R15, R16	Resistor, 10 k Ω , 1%, 1/10 W, 0603	Digi-Key	ERJ-3EKF1002V
1	R17	Resistor, 2 Ω , 5%, 1/10 W, 0603	Digi-Key	ERJ-3GEYJ2R0V
3	R18, R21, R22	Resistor, 0 Ω , 50 m Ω max, 1/10 W, 0603	Digi-Key	ERJ-3GEY0R00V
1	R23	Resistor, 47.5 k Ω , 1%, 1/10 W, 0603	Digi-Key	ERJ-3EKF4752V
2	R25, R26	Resistor, 200 Ω , 1%, 1/10 W, 0603	Digi-Key	ERJ-3EKF2000V

RELATED LINKS

Resource	Description
ADP1053	Product Page, 3-Channel Digital Power Supply Controller
ADP-I2C-USB-Z	Product Page, USB to I ² C Interface Connector