

ADSP-BF707 EZ-KIT Lite® Evaluation System Manual

Revision 1.0, May 2014

Part Number
82-000707-01

Analog Devices, Inc.
One Technology Way
Norwood, Mass. 02062-9106



Copyright Information

©2014 Analog Devices, Inc., ALL RIGHTS RESERVED. This document may not be reproduced in any form without prior, express written consent from Analog Devices, Inc.

Printed in the USA.

Disclaimer

Analog Devices, Inc. reserves the right to change this product without prior notice. Information furnished by Analog Devices is believed to be accurate and reliable. However, no responsibility is assumed by Analog Devices for its use; nor for any infringement of patents or other rights of third parties which may result from its use. No license is granted by implication or otherwise under the patent rights of Analog Devices, Inc.

Trademark and Service Mark Notice

The Analog Devices logo, Blackfin, CrossCore, EngineerZone, EZ-Board, and EZ-KIT Lite are registered trademarks of Analog Devices, Inc.

Blackfin+ is a trademark of Analog Devices, Inc.

All other brand and product names are trademarks or service marks of their respective owners.

Regulatory Compliance

The ADSP-BF707 EZ-KIT Lite is designed to be used solely in a laboratory environment. The board is not intended for use as a consumer end product or as a portion of a consumer end product. The board is an open system design which does not include a shielded enclosure and therefore may cause interference to other electrical devices in close proximity. This board should not be used in or near any medical equipment or RF devices.

The ADSP-BF707 EZ-KIT Lite is in the process of being certified to comply with the essential requirements of the European EMC directive 2004/108/EC and therefore carries the “CE” mark.



The EZ-KIT Lite evaluation system contains ESD (electrostatic discharge) sensitive devices. Electrostatic charges readily accumulate on the human body and equipment and can discharge without detection. Permanent damage may occur on devices subjected to high-energy discharges. Proper ESD precautions are recommended to avoid performance degradation or loss of functionality. Store unused EZ-KIT Lite boards in the protective shipping package.



CONTENTS

PREFACE

Product Overview	x
Purpose of This Manual	xiii
Intended Audience	xiii
Manual Contents	xiv
What's New in This Manual	xiv
Technical Support	xv
Supported Processors	xv
Supported Tools	xvi
Product Information	xvi
Analog Devices Web Site	xvi
EngineerZone	xvii
Notation Conventions	xvii

Contents

USING ADSP-BF707 EZ-KIT LITE

Package Contents	1-2
ADSP-BF707 EZ-Board	1-3
Default Configuration	1-3
EZ-KIT Lite Installation	1-5
EZ-KIT Lite Session Startup	1-6
Evaluation License	1-8
DDR2 Memory	1-8
SPI Flash	1-9
Housekeeping ADC	1-10
UART0 Interface	1-10
CAN0 Interface	1-10
CAN1 Interface	1-11
USB Interface	1-11
SD Interface	1-12
Debug Interface	1-12
Power-On-Self Test	1-12
Expansion Interface	1-13
Power Architecture	1-13
Power Measurements	1-14
Example Programs	1-14
Reference Design Information	1-15

ADSP-BF707 EZ-KIT LITE HARDWARE REFERENCE

System Architecture	2-2
Software-Controlled Switches (SoftConfig)	2-3
Overview of SoftConfig	2-3
SoftConfig on the ADSP-BF707 EZ-KIT LITE	2-7
Programming SoftConfig Switches	2-8
Push Buttons and Switches	2-16
Boot Mode Select Switch (SW1)	2-17
Reset Push Button (SW2)	2-17
GPIO Push Buttons (SW3-4)	2-17
Jumpers	2-18
Power Jumpers (P8-12, P14-18)	2-18
LEDs	2-19
GPIO LEDs (LED3-5)	2-20
Reset LED (LED6)	2-20
Power LED (LED2)	2-20
SYS_FAULT LED (LED1)	2-20
Connectors	2-21
Expansion Interface III Connectors (P1A-C)	2-22
Power Connector (P13)	2-22
USB to UART Connector (P6)	2-22
USB Connector (P5)	2-23
RF Wireless Connector (J3)	2-23
HADCSMC Connectors (J7, J8, J9)	2-23

Contents

HADC Connector (JP1)	2-24
SD Connector (J6)	2-24
CAN0 Connector (J4)	2-24
CAN1 Connector (J5)	2-25
JTAG/SWD/SWO Connector (P3)	2-25
TRACE and JTAG/SWD/SWO Connector (P2)	2-25

ADSP-BF707 EZ-KIT LITE BILL OF MATERIALS

ADSP-BF707 EZ-KIT LITE SCHEMATIC

INDEX

PREFACE

Thank you for purchasing the ADSP-BF707 EZ-KIT Lite[®], Analog Devices, Inc. low-cost evaluation system for the ADSP-BF70x Blackfin[®] processors.

The ADSP-BF707 processor is a member of the Blackfin family of products. Blackfin processors combine a dual-MAC state-of-the-art signal processing engine, the advantages of a clean, orthogonal RISC-like microprocessor instruction set, and single-instruction, multiple-data (SIMD) multimedia capabilities into a single instruction-set architecture. New enhancements to the Blackfin+[™] core add 32-bit MAC and 16-bit complex MAC support, cache enhancements, branch prediction and other instruction set improvements—all while maintaining instruction set compatibility to previous Blackfin products.

The EZ-KIT Lite is shipped with all of the necessary hardware—you can start the evaluation immediately. The package contains the standalone evaluation board, CE-approved power supply, and USB cable. The EZ-KIT Lite version ships with an ICE-1000 emulator, while the EZ-Board[®] version is supported by the ICE-1000 or ICE-2000 emulator.

Expansion Interface III is provided for connecting a camera or audio extender board.

Traditional mechanical switches for changing the board's factory setup have been removed in favor of I²C controlled software switches. The only remaining mechanical switches are the boot mode switch and push buttons.

Product Overview

The evaluation board is designed to be used in conjunction with the CrossCore® Embedded Studio (CCES) development tools to test capabilities of the ADSP-BF707 Blackfin processors. The CCES development environment aids advanced application code development and debug, such as:

- Create, compile, assemble, and link application programs written in C++, C, and assembly
- Load, run, step, halt, and set breakpoints in application programs
- Read and write data and program memory
- Read and write core and peripheral registers

Product Overview

The board features:

- Analog Devices ADSP-BF707 processor
 - 184-ball BGA package
 - 25 MHz CLKIN core oscillator
- DDR2 memory (DMC0) chip
 - 128M x 16-bit (2G bit)
 - Micron MT47H128M16
- Quad SPI Flash (SPI2)
 - 32M bit serial flash memory
 - Winbond W25Q32

- RF Wireless
 - 4 x 2 connector
 - 0.05” socket
- Universal Asynchronous Receiver/Transmitter (UART0)
 - FTDI FT232RQ USB to UART converter
 - USB Mini B connector
- Controller Area Network (CAN) interfaces
 - CAN0—NXP TJA1041 transceiver and RJ11 connector
 - CAN1—NXP TJA1041 transceiver and RJ11 connector
- USB0 interface
 - Micro AB connector
- HADC
 - VIN0 RTC battery through jumper
 - VIN1 timer through RC
 - VIN2 0.1” header
 - VIN3 0.1” header
- RTC
 - 16MM coin connector
 - 3V 125 mAh Li-ion
 - CR1632

Product Overview

- RESET controller
 - Analog Devices ADM6315 microprocessor supervisory circuits
- Debug (JTAG/SWD/TRACE) interface
 - JTAG/SWD/SWO 10-pin 0.05” header for use with ADI emulators
 - TRACE/JTAG/SWD 38-pin Mictor header
- Power measurement
 - INA3221 to measure 3V, VDD_INT and VDD_EXT
 - INA230 to measure VDD_DMC0
- LEDs
 - Six LEDs: one power (green), one board reset (red), one SYS_FAULT (red), and three general-purpose (amber)
- Push buttons
 - Three push buttons: one reset and two IRQ/Flag
- Expansion Interface III connectors (EI3)
 - SMC0
 - PPI
 - SPORT
 - SPI
 - UART
 - TWI
 - TMR

- GPIOs
- PWR_IN
- GND/3.3V output
- External power supply
 - CE compliant
 - 5V @ 3.6 Amps
- Other features
 - SD/MMC memory connector
 - Boot mode switch
 - 0.05-ohm resistors for processor current measurement

For information about the hardware components of the EZ-KIT Lite, refer to [ADSP-BF707 EZ-KIT Lite Bill Of Materials](#).

Purpose of This Manual

The *ADSP-BF707 EZ-KIT Lite Evaluation System Manual* provides instructions for installing the product hardware (board). The text describes operation and configuration of the board components and provides guidelines for running your own code on the ADSP-BF707 EZ-KIT Lite. Finally, a schematic and a bill of materials are provided for reference.

Intended Audience

The primary audience for this manual is a programmer who is familiar with Analog Devices processors. This manual assumes that the audience has a working knowledge of the appropriate processor architecture, instruction set, and C/C++ programming languages.

Manual Contents

Programmers who are unfamiliar with Analog Devices processors can use this manual, but should supplement it with other texts (such as the *ADSP-BF70x Blackfin+ Processor Hardware Reference* and the *ADSP-BF70x Blackfin+ Processor Programming Reference*) that describe your target architecture.

Programmers who are unfamiliar with CrossCore Embedded Studio should refer to the CCES online help.

Manual Contents

The manual consists of:

- Chapter 1, [Using ADSP-BF707 EZ-KIT Lite](#)
Describes EZ-KIT Lite functionality from a programmer's perspective and provides a simplified memory map of the processor.
- Chapter 2, [ADSP-BF707 EZ-KIT Lite Hardware Reference](#)
Provides information about the EZ-KIT Lite hardware components.
- Appendix A, [ADSP-BF707 EZ-KIT Lite Bill Of Materials](#)
Provides a list of hardware components used to manufacture the EZ-KIT Lite board.
- Appendix B, [ADSP-BF707 EZ-KIT Lite Schematic](#)
Lists the resources for board-level debugging.

What's New in This Manual

This is the first revision (Revision 1.0) of the *ADSP-BF707 EZ-KIT Lite Evaluation System Manual*.

Technical Support

You can reach Analog Devices processors and DSP technical support in the following ways:

- Post your questions in the processors and DSP support community at EngineerZone[®]:
<http://ez.analog.com/community/dsp>
- Submit your questions to technical support directly at:
<http://www.analog.com/support>
- E-mail your questions about processors and processor applications to:
processor.support@analog.com or
processor.china@analog.com (Greater China support)
- Contact your Analog Devices sales office or authorized distributor. Locate one at:
www.analog.com/adi-sales
- Send questions by mail to:
Processors and DSP Technical Support
Analog Devices, Inc.
Three Technology Way
P.O. Box 9106
Norwood, MA 02062-9106
USA

Supported Processors

This evaluation system supports Analog Devices ADSP-BF707 Blackfin processors.

Supported Tools

Information on supported tools for the ADSP-BF707 EZ-KIT Lite and the ADSP-BF70x family of Blackfin processors is available at:

<http://www.analog.com/BF707EZKit>

Product Information

Product information can be obtained from the Analog Devices Web site and the online help system.

Analog Devices Web Site

The Analog Devices Web site, www.analog.com, provides information about a broad range of products—*analog integrated circuits, amplifiers, converters, and digital signal processors.*

To access a complete technical library for each processor family, go to http://www.analog.com/processors/technical_library. The manuals selection opens a list of current manuals related to the product as well as a link to the previous revisions of the manuals. When locating your manual title, note a possible errata check mark next to the title that leads to the current correction report against the manual.

Also note, myAnalog.com is a free feature of the Analog Devices Web site that allows customization of a Web page to display only the latest information about products you are interested in. You can choose to receive weekly e-mail notifications containing updates to the Web pages that meet your interests, including documentation errata against all manuals. myAnalog.com provides access to books, application notes, data sheets, code examples, and more.

Visit myAnalog.com (found on the Analog Devices home page) to sign up. If you are a registered user, just log on. Your user name is your e-mail address.

EngineerZone

EngineerZone is a technical support forum from Analog Devices. It allows you direct access to ADI technical support engineers. You can search FAQs and technical information to get quick answers to your embedded processing and DSP design questions.



Use EngineerZone to connect with other DSP developers who face similar design challenges. You can also use this open forum to share knowledge and collaborate with the ADI support team and your peers. Visit <http://ez.analog.com> to sign up.

Notation Conventions

Text conventions used in this manual are identified and described as follows.

Example	Description
File > Close	Titles in reference sections indicate the location of an item within the CCES environment's menu system (for example, the Close command appears on the File menu).
{this that}	Alternative required items in syntax descriptions appear within curly brackets and separated by vertical bars; read the example as <i>this</i> or <i>that</i> . One or the other is required.
[this that]	Optional items in syntax descriptions appear within brackets and separated by vertical bars; read the example as an optional <i>this</i> or <i>that</i> .
[this,...]	Optional item lists in syntax descriptions appear within brackets delimited by commas and terminated with an ellipse; read the example as an optional comma-separated list of <i>this</i> .

Notation Conventions

Example	Description
.SECTION	Commands, directives, keywords, and feature names are in text with letter gothic font.
<i>filename</i>	Non-keyword placeholders appear in text with italic style format.
	Note: For correct operation, ... A Note provides supplementary information on a related topic. In the online version of this book, the word Note appears instead of this symbol.
	Caution: Incorrect device operation may result if ... Caution: Device damage may result if ... A Caution identifies conditions or inappropriate usage of the product that could lead to undesirable results or product damage. In the online version of this book, the word Caution appears instead of this symbol.
	Warning: Injury to device users may result if ... A Warning identifies conditions or inappropriate usage of the product that could lead to conditions that are potentially hazardous for the devices users. In the online version of this book, the word Warning appears instead of this symbol.

1 USING ADSP-BF707 EZ-KIT LITE

This chapter provides information to assist you with development of programs for the ADSP-BF707 EZ-KIT Lite evaluation system.

The following topics are covered.

- [Package Contents](#)
- [ADSP-BF707 EZ-Board](#)
- [Default Configuration](#)
- [EZ-KIT Lite Installation](#)
- [EZ-KIT Lite Session Startup](#)
- [Evaluation License](#)
- [DDR2 Memory](#)
- [SPI Flash](#)
- [Housekeeping ADC](#)
- [UART0 Interface](#)
- [CAN0 Interface](#)
- [CAN1 Interface](#)
- [USB Interface](#)
- [SD Interface](#)

Package Contents

- [Debug Interface](#)
- [Power-On-Self Test](#)
- [Expansion Interface](#)
- [Power Architecture](#)
- [Power Measurements](#)
- [Example Programs](#)
- [Reference Design Information](#)

Package Contents

Your ADSP-BF707 EZ-KIT Lite package contains the following items.

- ADSP-BF707 EZ-Board
- Universal 5V DC power
- USB A to micro B cable
- USB micro A to A receptacle cable
- ICE-1000 (only in the EZ-LIT Lite version)
- Standoffs and screws in a bag
- Release note
- 2GB SD card

Contact the vendor where you purchased your EZ-KIT Lite or contact Analog Devices, Inc. if any item is missing.

ADSP-BF707 EZ-Board

The ADSP-BF707 EZ-KIT Lite is shipped with an ICE-1000 emulator. When the product is not shipped with the emulator, it is referred to as the ADSP-BF707 EZ-Board.

 The EZ-Board requires an ICE-1000 or ICE-2000 emulator.

Default Configuration

The ADSP-BF707 EZ-KIT Lite board is designed to run as a standalone unit.

When removing the EZ-KIT Lite board from the package, handle the board carefully to avoid the discharge of static electricity, which can damage some components.

The EZ-KIT Lite evaluation system contains ESD (electrostatic discharge) sensitive devices. Electrostatic charges readily accumulate on the human body and equipment and can discharge without detection. Permanent damage may occur on devices subjected to high-energy discharges. Proper ESD precautions are recommended to avoid performance degradation or loss of functionality. Store unused EZ-KIT Lite boards in the protective shipping package.



Default Configuration

Figure 1-1 shows the default jumper settings and boot mode switch used in installation. Confirm that your board is in the default configuration before using the board.

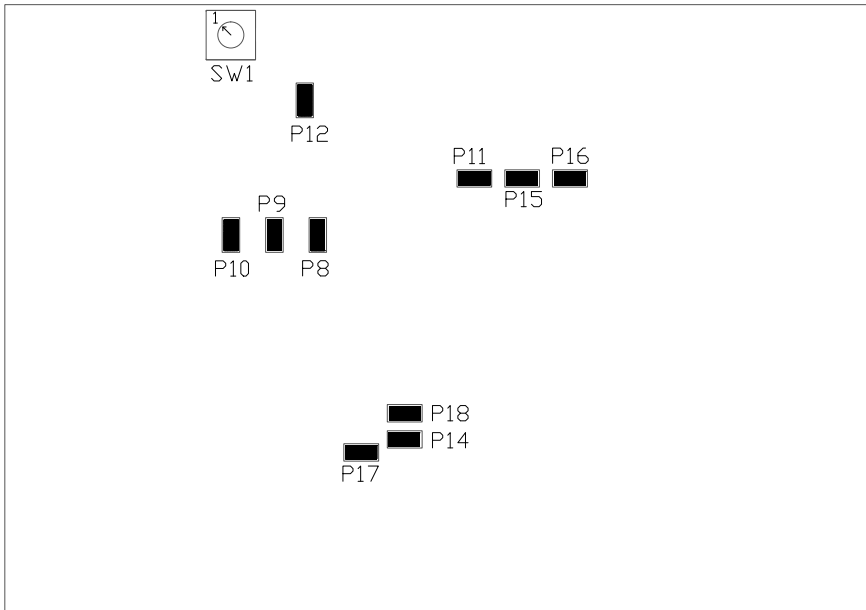

Figure 1-1. Default EZ-KIT Lite Hardware Setup

EZ-KIT Lite Installation

It is assumed that the CrossCore Embedded Studio software is installed and running on your PC.

Follow these instructions to ensure correct operation of the product software and hardware.

Step 1: Connecting an emulator to the EZ-KIT Lite.

1. Plug one side of the included USB cable into the USB connector of the emulator. Plug the other side into a USB port of the PC.
2. The status LED (labeled `STATUS`) should light up green if the connection with the PC is working and the appropriate Windows driver is installed. Please refer to the appropriate emulator manual if the status LED does not turn on.
3. Attach the emulator header (`J2` on the bottom of the ICE-1000 to the `P3` connector on the EZ-KIT Lite.

Step 2: Attach the provided cord and appropriate plug to the 5V power adaptor.

1. Plug the jack-end of the assembled power adaptor into the power connector `P13` (labeled `5V`) on the EZ-KIT Lite.
2. Plug the other side of the power adaptor into a power outlet. The power LED (labeled `PWR`) lights green when power is applied to the board.

EZ-KIT Lite Session Startup

It is assumed that the CrossCore Embedded Studio software is installed and running on your PC.

 Note: If you connect the board or emulator first (before installing CCES) to the PC, the Windows driver wizard may not find the board drivers.

1. Navigate to the CCES environment via the **Start** menu.

Note that CCES is not connected to the target board.

2. Use the Debug Configurations wizard to connect to the EZ-KIT Lite board.

If a debug configuration exists already, select the appropriate configuration and click **Debug**. Go to step 8.

To create a debug configuration, do one of the following:

- Click the down arrow next to the bug icon  , select **Debug Configurations**
- Choose **Run > Debug Configurations**.

The **Debug Configuration** dialog box appears.

3. Select **CrossCore Embedded Studio Application** and click  (New launch configuration).

The **Select Processor** page of the **Session Wizard** appears.

4. Ensure **Blackfin** is selected in **Processor family**. In **Processor type**, select **ADSP-BF707**. Click **Next**.

The **Select Connection Type** page of the **Session Wizard** appears.

5. Select **Emulator** and click **Next**.



The **Select Platform** page of the **Session Wizard** appears.



6. Choose the type of emulator that is connected to the EZ-KIT Lite.
7. Click **Finish** to close the wizard.

The new debug configuration is created and added to the **Debug Configurations** list.

8. In the **Name** edit box, users can select an appropriate name to describe the configuration, otherwise a default name is provided.
9. In the **Program(s) to load** section, choose the program to load (if the appropriate program is not already populated) when connecting to the board. If not loading any program upon connection to the target, do not make any changes.

 While connected to the target, there is no way to choose a program to download. To load a program once connected, terminate the session and then load the new program.

 To delete a configuration, go to the **Debug Configurations** dialog box and select the configuration to delete. Click  and choose **Yes** when asked if you wish to delete the selected launch configuration. Then **Close** the dialog box.

 To disconnect from the target board, click the terminate button  or choose **Run > Terminate**.

To delete a session, choose **Target > Session > Session List**. Select the session name from the list and click **Delete**. Click **OK**.

 The default configurations that show up in the CCES Debug Configurations wizard are for JTAG mode debugging only. To use SWD mode, a new platform will need to be created using the **Target Configurator**.

Evaluation License

When starting CCES for the first time, you will be prompted to install either a 90-day evaluation license or a permanent, full license. To automatically install an unrestricted 90-day evaluation license, select “I do not have a serial number and would like to evaluate the product”. If the evaluation license is installed but not activated, it allows 10 days of unrestricted use and then becomes disabled. The license can be re-enabled by activation. Once activated, the evaluation license offers 90 days of unrestricted use and then becomes permanently disabled.

An evaluation license can be upgraded to a full license. Licenses can be purchased from:

- Analog Devices directly. Call (800) 262-5645 or 781-937-2384 or go to:
<http://www.analog.com/buyonline>.
- Analog Devices, Inc. local sales office or authorized distributor. To locate one, go to:
www.analog.com/adi-sales.



The EZ-KIT Lite hardware must be connected and powered up to use CCES with a valid evaluation or full license.

DDR2 Memory

The ADSP-BF707 processor connects to a 2Gb Micron MT47H128M16 chip through the Double Data Rate Synchronous Dynamic Random-Access Memory (DDR2 SDRAM) controller. The DDR2 memory controller on the processor and the DDR2 memory chip are powered by the on-board 1.8V regulator. Data is transferred between the processor and DDR2 on both the rising and falling edges of the DDR2 clock. The DDR2 controller on the processor can operate at a maximum clock frequency of 200 MHz.

With a CCES session running and connected to the EZ-KIT Lite via an emulator, the DDR2 registers are configured automatically each time the processor is reset through a soft reset using CCES. The values are used whenever DDR2 is accessed through the debugger (for example, when viewing memory or loading a program).

To disable the automatic setting of the DDR2 registers, select **Target Options** from the **Session** menu in CCES and uncheck **Use XML reset values**.

An example program is included in the EZ-KIT Lite installation directory to demonstrate how to set up and access the DDR2 interface. For more information on how to initialize the registers after a reset, refer to the hardware reference manual.

SPI Flash

The ADSP-BF707 processor has three SPI interfaces: SPI0, SPI1, and SPI2. SPI2 is connected to a Winbond W25Q32BC 32 Mb serial flash memory with dual and quad SPI support. This flash is used for booting and scratchpad space.

Quad mode is enabled by default. The processor flag signals, PB_15 (SPI2_SEL1), PB_13 (SPI2_D2), and PB_14 (SPI2_D3) are connected by default and can be disconnected by using SoftConfig. Refer to [Software-Controlled Switches \(SoftConfig\)](#) for more information.

For more information, refer to the SPI flash example in the POST, which is included in the ADSP-BF707 Board Support Package.

Housekeeping ADC

The ADSP-BF707 processor provides four housekeeping ADC inputs: HADCO_VIN0 through HADC_VIN3. The EZ-KIT Lite connects HADCO_VIN0 to pin 2 of a four position 0.1" header (JP1). JP1 has VDD_RTC voltage domain on pin 1, allowing a jumper to connect the voltage back to the processor. Pin 4 of JP1 connects through an RC timer to HADCO_VIN1.

HADC_VIN2 and HADC_VIN3 are connected to SMC connectors (J7 and J8). Refer to [ADSP-BF707 EZ-KIT Lite Schematic](#) for more information.

UART0 Interface

The ADSP-BF707 processor has two built-in universal asynchronous transmitters (UARTs). UART0 is connected to an FTDI, FT232RQ, USB to UART converter IC (U45).

The UART functionality is connected by default through SoftConfig. Refer to [Software-Controlled Switches \(SoftConfig\)](#) for more information.

For more information, refer to the UART0 example in the POST, which is included in the ADSP-BF707 Board Support Package.

CAN0 Interface

The Controller Area Network 0 (CAN0) interface of the EZ-KIT Lite is connected to the NXP TJA1041 CAN transceiver (U46). The transceiver is attached to the CAN0 port of the ADSP-BF707 processor via an RJ-11 connector (J4). See [CAN0 Connector \(J4\)](#).

The CAN0 transmit, receive, and error signals are connected through the SoftConfig switches and disabled by default. CAN0_EN is enabled by default and CAN0_STB is disabled. See [Software-Controlled Switches \(SoftConfig\)](#).

For more information, refer to the CAN0 example in the POST, which is included in the ADSP-BF707 Board Support Package.

CAN1 Interface

The Controller Area Network 1 (CAN1) interface of the EZ-KIT Lite is connected to the NXP TJA1041 CAN transceiver (U47). The transceiver is attached to the CAN1 port of the ADSP-BF707 processor via an RJ-11 connector (J5). See [CAN1 Connector \(J5\)](#).

The CAN1 transmit and receive signals are connected through the SoftConfig switches and enabled by default. CAN1_EN is enabled by default. CAN1_ERR_EN (error) and CAN1_STB are disabled. See [Software-Controlled Switches \(SoftConfig\)](#).

For more information, refer to the CAN1 example in the POST, which is included in the ADSP-BF707 Board Support Package.

USB Interface

The ADSP-BF707 processor has an integrated USB PHY; the EZ-KIT Lite provides a micro AB connector. The board supports USB high speed mode.

The board supplies a maximum of 5V at 500 mA to a peripheral device by enabling the FET switch (U40). The USB controller controls the FET switch through the USB0_VBC signal.

To learn about the processor's device and host modes, refer to the USB example in the POST, which is included in the ADSP-BF707 Board Support Package. For more information, refer to the hardware reference manual.

SD Interface

The ADSP-BF707 processor has a secure digital (SD) interface that consists of a clock pin, command pin, card detect pin, and an 8-bit data bus. SoftConfig controls the connection of the card detect pin (PA_08) and a GPIO pin used for write protect (PB_07). Refer to [Software-Controlled Switches \(SoftConfig\)](#) and [SD Connector \(J6\)](#) for more details.

An example program is included in the ADSP-BF707 Board Support Package.

Debug Interface

The EZ-KIT Lite provides a JTAG/SWD/SWO connection via connector (P3), which is a 0.05” pitch header. An 8-bit trace connection also is available via connector (P2), although this is not supported at this time. See [JTAG/SWD/SWO Connector \(P3\)](#) and [TRACE and JTAG/SWD/SWO Connector \(P2\)](#) for more information.

Power-On-Self Test

The Power-On-Self-Test Program (POST) tests all EZ-KIT Lite peripherals and validates functionality as well as connectivity to the processor. Once assembled, each EZ-KIT Lite is fully tested for an extended period of time with POST. All EZ-KIT Lite boards are shipped with POST pre-loaded into flash memory. The POST is executed by resetting the board and pressing the proper push button(s). The POST also can be used as a reference for a custom software design or hardware troubleshooting.

Note that the source code for the POST program is included in the ADSP-BF707 Board Support Package along with the `readme.txt` file that describes how the board is configured to run POST.

Expansion Interface

The expansion interface allows a custom-design daughter board to be tested across various hardware platforms that have the same expansion interface.

The Expansion Interface III (EI3) implemented on the ADSP-BF707 EZ-KIT Lite consists of three connectors: P1A, P1B, and P1C. The connectors contain a majority of the processor's signals. For pinout information, go to [ADSP-BF707 EZ-KIT Lite Schematic](#).

Limits to current and interface speed must be taken into consideration when using the expansion interface. Current for extenders connected to the EI3 connectors can be sourced from the EZ-KIT Lite; therefore, the current should be limited to 250 mA for 5V, and 300 mA from the 3.3V planes. If more current is required, a separate power connector and a regulator must be designed on the daughter card. Additional circuitry implemented on extender cards can add extra loading to signals, decreasing their maximum effective speed.



Analog Devices does not support and is not responsible for the effects of additional circuitry.

Power Architecture

The ADSP-BF707 EZ-KIT Lite has three primary voltage domains: 3.3V, 1.1V, and 1.8V. The power input is a 5V wall adaptor.

The Analog Devices ADP5024 controller provides all three voltage levels, 3.3V for the `VDD_EXT` signal and the 3.3V power requirements of the board, the `VDD_INT` signal (1.1V), as well as the `VDD_DMC0` signal (1.8V).

The voltage levels can be measured using INA3221 IC (U48) for 3.3V, `VDD_INT`, and `VDD_EXT`. Current consumption of the power rail could be measured with this same device when the corresponding jumper is

Power Measurements

removed. See [Power Measurements](#) for more information. The voltage level of `VDD_DMC0` can be measured by using the INA230 IC (U31) and the current consumption of the domain, if the jumper is removed. See [Power Measurements](#) section for more information

A FET switch (U40) controls the 5V to the USB devices over the `USB0_VBUS` signal.

Power Measurements

Locations are provided for measuring the current draw from various power planes. Precision 0.05 ohm shunt resistors are available on the `VDD_EXT`, `VDD_INT`, `USB0_VBUS`, and 3.3V and voltage domains. For current draw, the jumper is removed, voltage across the resistor can be measured using an oscilloscope, and the value of the resistor can be measured using a precision multi-meter. Once voltage and resistance are measured, the current can be calculated by dividing the voltage by the resistance. For the highest accuracy, a differential probe should be used for measuring the voltage across the resistor.

There are also ICs (U48 and U31) that can be used to measure the current consumption of each power rail in software when the jumper is removed. For more information, refer to [Power Jumpers \(P8-12, P14-18\)](#).

Example Programs

Example programs are provided with the ADSP-BF707 Board Support Package to demonstrate various capabilities of the product. The programs can be found in the `ADSP-BF707_EZ-Board-Rel1.0.0\examples` folder. The number after the “Rel” could be higher for newer versions. Refer to a readme file provided with each example for more information.

Reference Design Information

A reference design info package is available for download on the Analog Devices Web site. The package provides information on the design, layout, fabrication, and assembly of the EZ-KIT Lite.

The information can be found at:

<http://www.analog.com/BF707EZKit>

Reference Design Information

2 ADSP-BF707 EZ-KIT LITE HARDWARE REFERENCE

This chapter describes the hardware design of the ADSP-BF707 EZ-KIT Lite board.

The following topics are covered.

- [System Architecture](#)
Describes the board's configuration and explains how the board components interface with the processor.
- [Software-Controlled Switches \(SoftConfig\)](#)
Lists and describes the processor signals routed through the software-controlled switches.
- [Push Buttons and Switches](#)
Shows the locations and describes the push buttons and switches.
- [Jumpers](#)
Shows the locations and describes the configuration jumpers.
- [LEDs](#)
Shows the locations and describes the LEDs.
- [Connectors](#)
Shows the locations and provides part numbers for the on-board connectors. In addition, the manufacturer and part number information is provided for the mating parts.

System Architecture

This section describes the processor's configuration on the EZ-KIT Lite board (Figure 2-1).

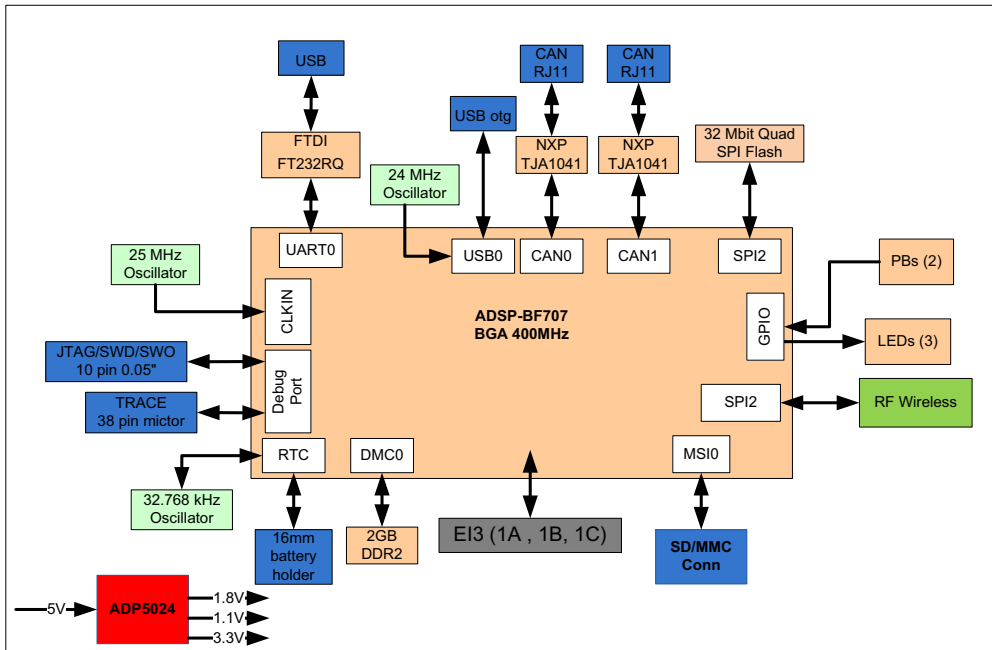

Figure 2-1. EZ-KIT Lite Block Diagram

This EZ-KIT Lite is designed to demonstrate the ADSP-BF707 processor's capabilities. The ADSP-BF707 EZ-KIT Lite has a 25 MHz input clock and runs at 400 MHz internally.

USB circuitry and a micro USB AB connector are provided for connecting to the EZ-KIT Lite as a host or a device. The frequency for the USB circuit is generated by an external 24 MHz oscillator.

User I/O to the processor is provided in the form of two user push buttons and three LEDs. The software-controlled switches (SoftConfig) facilitate the switch multi-functionality by disconnecting the push buttons from their associated processor pins and reusing the pins elsewhere on the board. See [ADSP-BF707 EZ-KIT Lite Schematic](#) for more information.

Software-Controlled Switches (SoftConfig)

On the ADSP-BF707 EZ-KIT Lite, most of the traditional mechanical switches have been replaced by I²C software-controlled switches. The remaining mechanical switches are provided for the boot mode and push buttons. Reference any `SoftConfig*.c` file found in the installation directory for an example of how to set up the SoftConfig feature of the ADSP-BF707 EZ-KIT Lite through software.

The SoftConfig section of this manual serves as a reference to any user that intends to modify an existing software example. If software provided from ADI is used, there should be little need to reference this section.

 Care should be taken when changing SoftConfig settings not to create a conflict with interfaces. This is especially true when connecting extender cards.

Overview of SoftConfig

In order to further clarify the use of electronic single FET switches and multi-channel bus switches, an example of each is illustrated and compared to a traditional mechanical switching solution. This is a generic example that uses the same FET and bus switch components that are on the EZ-KIT Lite.

After this generic discussion there is a detailed explanation of the SoftConfig interface specific to the ADSP-BF707 EZ-KIT Lite.

Software-Controlled Switches (SoftConfig)

Figure 2-2 shows two individual FET switches (Pericom PI3A125CEX) with reference designators UA and UB. Net names `ENABLE_A` and `ENABLE_B` control UA and UB. The default FET switch enable settings in this example are controlled by resistors `RA` and `RB` which pull the enable pin 1 of UA and UB to ground (low). In a real example, these enable signals are controlled by the Microchip IO expander. The default pull-down resistors connects the signals `EXAMPLE_SIGNAL_A` and `EXAMPLE_SIGNAL_B` and also connects signals `EXAMPLE_SIGNAL_C` and `EXAMPLE_SIGNAL_D`. To disconnect `EXAMPLE_SIGNAL_A` from `EXAMPLE_SIGNAL_B`, the Microchip IO expander is used to change `ENABLE_A` to a logic 1 through software that interfaces with the Microchip. The same procedure for `ENABLE_B` would disconnect `EXAMPLE_SIGNAL_C` from `EXAMPLE_SIGNAL_D`.

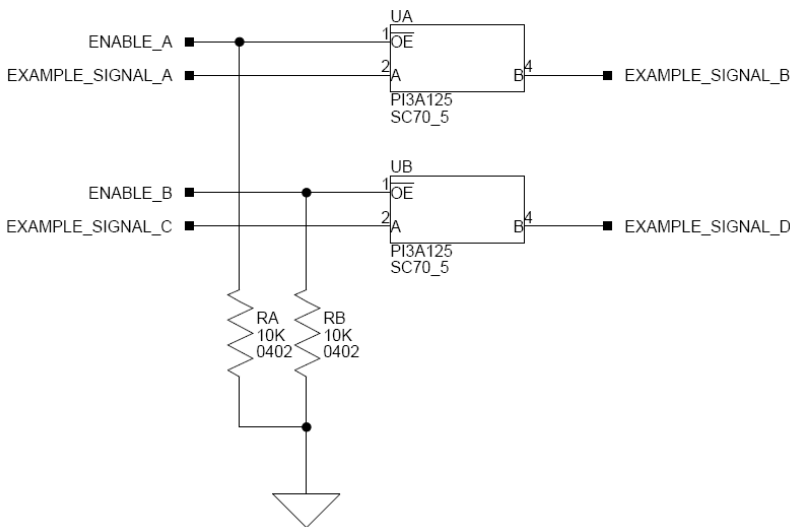

Figure 2-2. Example of Individual FET Switches

Figure 2-3 shows the equivalent circuit to Figure 2-2 but utilizes mechanical switches that are in the same package. Notice the default is shown by black boxes located closer to the ON label of the switches. In order to disconnect these switches, physically move the switch to the OFF position.

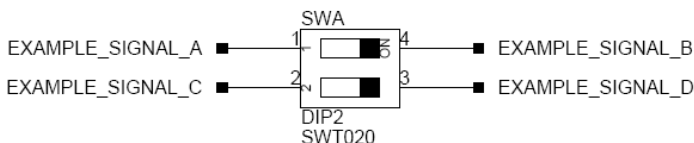

Figure 2-3. Example of Mechanical Switch Equivalent to Figure 2-2

Figure 2-4 shows a bus switch example, reference designator UC (Pericom PI3LVD512ZHE), selecting between lettered functionality and numbered functionality. The signals on the left side are multiplexed signals with naming convention `letter_number`. The right side of the circuit shows the signals separated into letter and number, with the number on the lower group (eg. 0B1) and the letter on the upper group (eg. 0B2). The default setting is controlled by the signal `CONTROL_LETTER_NUMBER` which is pulled low. This selects the number signals on the right to be connected to the multiplexed signals on the left by default. In this example, the Microchip IO expander is not shown but controls the signal `CONTROL_LETTER_NUMBER` and allows the user to change the selection through software.

Figure 2-5 shows the equivalent circuit to Figure 2-4 but utilizes mechanical switches. Notice the default for reference designators SWC and SWD is illustrated by black boxes located closer to the ON label of the switches to enable the number signals by default. Also notice the default setting for reference designators SWE and SWF is OFF. In order to connect the letters instead of the numbers, the user physically changes all switches on SWC and SWD to the OFF position and all switches on SWE and SEF to the ON position.

Software-Controlled Switches (SoftConfig)

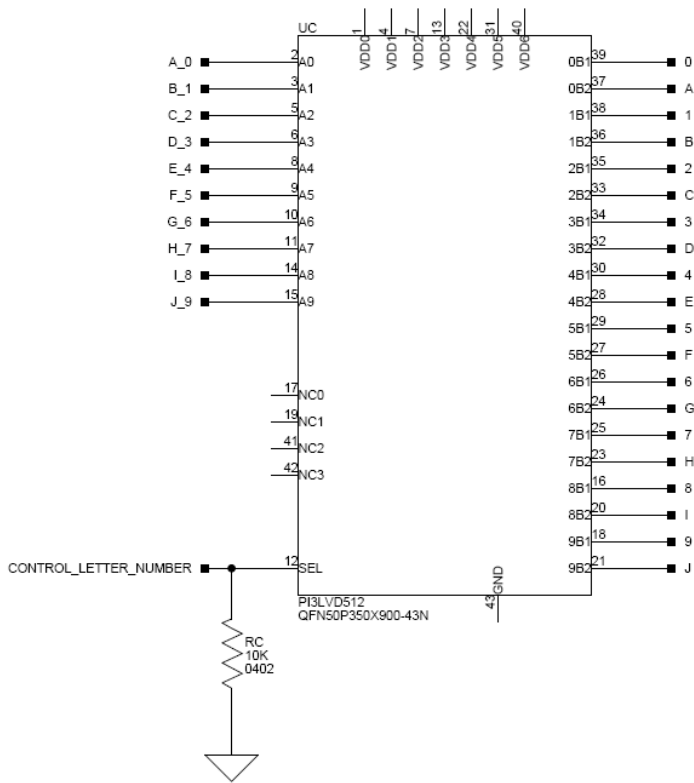

Figure 2-4. Example of Bus Switch

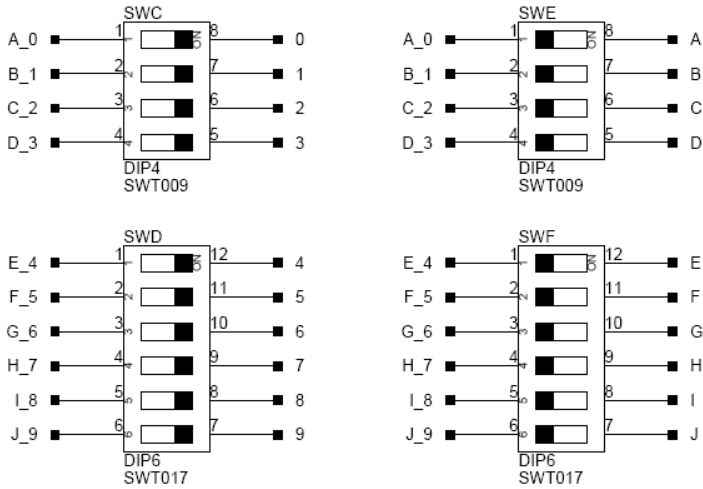

Figure 2-5. Example of Mechanical Switch Equivalent to [Figure 2-4](#)

SoftConfig on the ADSP-BF707 EZ-KIT LITE

Two Microchip MCP23017 GPIO expanders provide control for individual electronic switches. The TWI0 interface of the processor communicates with the Microchip devices. There are individual switches with default settings that enable basic board functionality.

[Table 2-1](#) lists the ADSP-BF707 processor and EZ-KIT Lite interfaces that are available by default. Note that only interfaces affected by software switches are listed in [Table 2-1](#).

Software-Controlled Switches (SoftConfig)

Table 2-1. Default ADSP-BF707 Processor Interface Availability

Interface	Availability by Default
UART0	USB to UART conversion through U45 (FTDI FT232RQ) with flow control
CAN0	Transmit/receive disabled
CAN1	Enabled
Push buttons	Enabled
LEDs	Enabled

Programming SoftConfig Switches

On the ADSP-BF707 EZ-KIT Lite, two Microchip MCP23017 devices exist. Each of these devices have the following programming characteristics:

- Each switch has two programmable GPIO registers.

GPIO Register	Register Address
GPIOA	0x12
GPIOB	0x13

- Each GPIO register controls eight signals (software switches).
- By default, the Microchip MCP23017 GPIO signals function as input signals.

The signals must be programmed as output signals to override their default values. The following tables ([Table 2-2](#) and [Table 2-3](#)) show the Microchip register addresses and the values that must be written to them to program the signals as output signals.

Table 2-2. IODIR for Hardware Address 0x41

IODIR Register	IODIR Register Address	Value to be Written to Program Signals as Outputs
IODIRA	0x00	0x40
IODIRB	0x01	0x03

Table 2-3. IODIR for Hardware Address 0x42

IODIR Register	IODIR Register Address	Value to be Written to Program Signals as Outputs
IODIRA	0x00	0x80
IODIRB	0x01	0x83

Each of the examples in the ADSP-BF707 Board Support Package include source files that program the soft switches, even if the default settings are being used. The `README` for each example identifies only the signals that are being changed from their default values. The code that programs the soft switches is located in the `SoftConfig_BF707.c` file, with a version number suffix, in each example.

The following tables ([Table 2-4](#) and [Table 2-5](#)) outline the default values for each of the two Microchip MCP23017 devices.

Table 2-4. I²C Hardware Address 0x41

GPIO	MCP23017 Register Address	Default Value
GPIOA	0x12	0xF8
GPIOB	0x13	0xFF

Software-Controlled Switches (SoffConfig)

Table 2-5. I²C Hardware Address 0x42

GPIO	MCP23017 Register Address	Default Value
GPIOA	0x12	0x85
GPIOB	0x13	0x83

The [ADSP-BF707 EZ-KIT Lite Schematic](#) shows how the two Microchip GPIO expanders are connected to the board's ICs.

Table 2-6 and Table 2-7 show the output signals of the Microchip GPIO expander (U39), with a TWI address of 0100 001X, where X represents the read or write bit. The signals that control an individual FET have an entry under the **FET** column. The **Component Connected** column shows the board IC that is connected if the FET is enabled. The Microchip (U39) is controlling the enable signal of a FET switch. Also note that if a particular functionality of the processor signal is being used, it will be in **bold font** under the **Processor Signal** column.

Table 2-6. Output Signals of Microchip GPIO Expander (U39 Port A)

Bit	Signal Name	Description	FET	Processor Signal (if applicable)	Component Connected	Default
0	$\overline{\text{SPIFLASH_CS_EN}}$	SPI flash CS	U3	PB_15/ SPI2_SEL1 / TRACE0_D00/ SMC0_D15/ $\overline{\text{SPI2_SS}}$	U33	Low
1	$\overline{\text{SPIFLASH_D2_EN}}$	SPI flash D2	U4	PB_13/ SPI2_D2 / UART1_RTS/ TRACE0_D02/ SMC0_D13	U33	Low
2	$\overline{\text{SPIFLASH_D3_EN}}$	SPI flash D3	U5	PB_14/ SPI2_D3 / UART1_CTS/ TRACE0_D01/ SMC0_D14	U33	Low
3	$\overline{\text{RF_SPI2_SEL1_EN}}$	RF wireless SPI chip select	U28	PB_15/ SPI2_SEL1 / TRACE0_D00/ SMC0_D15/ $\overline{\text{SPI2_SS}}$	J3	High

ADSP-BF707 EZ-KIT Lite Hardware Reference

Table 2-6. Output Signals of Microchip GPIO Expander
(U39 Port A) (Cont'd)

Bit	Signal Name	Description	FET	Processor Signal (if applicable)	Component Connected	Default
4	SD_CD_EN	MSIO card detect	U26	PA_08/EPPIO_D11/ MSIO_CD/SPT1_ACLK/ SMCO_A01	J6	High
5	SD_WP_EN	GPIO SD card write protect	U27	PB_07/EPPIO_D00/ SPT0_BD1/SPIO_D3/ SMCO_D00/SYS_WAKE0	J6	High
6	Not Used					
7	RF_SPI2_SEL2_EN	RF wireless SPI chip select	U29	PB_08/UART0_TX/ EP-PIO_D16/ SPI2_SEL2/ SMCO_D08/SYS_WAKE1	J3	High

Table 2-7. Output Signals of Microchip GPIO Expander
(U39 Port B)

Bit	Signal Name	Description	FET	Processor Signal (if applicable)	Component Connected	Default
0	Not Used					
1	Not Used					
2	CAN0_EN	Enables CAN0			U46	High
3	CAN0_STB	Puts CAN IC in standby			U46	High
4	CAN1_EN	Enables CAN1			U47	High
5	CAN1_STB	Puts CAN IC in standby			U47	High

Software-Controlled Switches (SoftConfig)

Table 2-7. Output Signals of Microchip GPIO Expander (U39 Port B) (Cont'd)

Bit	Signal Name	Description	FET	Processor Signal (if applicable)	Component Connected	Default
6	CANO_ERR_EN	Connects CAN error signal to processor	U6	PB_02 / EPPI0_D05/ SPT1_BD0/ SPI0_MOSI/ SMC0_D05	U46	High
7	CANI_ERR_EN	Connects CAN error signal to processor	U9	PB_03 / EPPI0_D04/ SPT1_BD1/ SPI0_D2/ SMC0_D04	U47	High

Table 2-8 and Table 2-9 show the output signals of the Microchip GPIO expander (U38), with a TWI address of 0100 010X, where X represents the read or write bit. The signals that control an individual FET have an entry under the **FET** column. The **Component Connected** column shows the board IC that is connected if the FET is enabled. Note that some of the Microchip (U38) output signals are connected directly to components on the board. However, in most cases, the Microchip (U38) is controlling the enable signal of a FET switch. Also note that if a particular functionality of the processor signal is being used, it will be in **bold font** under the **Processor Signal** column.

ADSP-BF707 EZ-KIT Lite Hardware Reference

Table 2-8. Output Signals of Microchip GPIO Expander
(U38 Port A)

Bit	Signal Name	Description	FET/ SWITCH	Processor Signal (if applicable)	Component Connected	Default
0	$\overline{\text{CAN0_TX_EN}}$	Enables CAN0 TX	U10	PC_03/ $\overline{\text{UART0_CTS}}$ / $\overline{\text{CAN0_TX}}$ / EPPI0_D12/ SMCO_A11/TM0_AC10	U46	High
1	$\overline{\text{CAN1_TX_EN}}$	Enables CAN1 TX	U7	PA_13/EPPI0_FS2/ $\overline{\text{CAN1_TX}}$ / $\overline{\text{SMCO_ARE}}$ / CNT0_ZM	U47	Low
2	$\overline{\text{CAN0_RX_EN}}$	Enables CAN0 RX	U11	PC_02/ $\overline{\text{UART0_RTS}}$ / $\overline{\text{CAN0_RX}}$ / EPPI0_D13/ SMCO_A10/ TM0_AC15/ SYS_WAKE3	U46	High
3	$\overline{\text{CAN1_RX_EN}}$	Enables CAN1 RX	U8	PA_12/EPPI0_FS1/ $\overline{\text{CAN1_RX}}$ / $\overline{\text{SMCO_A0E}}$ / TM0_AC16/ SYS_WAKE4	U47	Low
4	$\overline{\text{UART0_EN}}$	Enables UART0	U12/U13	PB_09/ $\overline{\text{UART0_RX}}$ / EPPI0_D17/ $\overline{\text{SPI2_SEL3}}$ / SMCO_D09/ TM0_AC13 and PB_08/ $\overline{\text{UART0_TX}}$ / EPPI0_D16/ $\overline{\text{SPI2_SEL2}}$ / SMCO_D08/ SYS_WAKE1	U45	Low
5	UART0RTS_EN	Enables UART0 RTS	U51	PC_02/ $\overline{\text{UART0_RTS}}$ / CAN0_RX/ EPPI0_D13/ SMCO_A10/ TM0_AC15/ SYS_WAKE3	U45	Low

Software-Controlled Switches (SoftConfig)

Table 2-8. Output Signals of Microchip GPIO Expander (U38 Port A) (Cont'd)

Bit	Signal Name	Description	FET/ SWITCH	Processor Signal (if applicable)	Component Connected	Default
6	UARTOCTS_EN	Enables UART0 CTS	U50	PC_03/ <u>UART0_CTS</u> / CAN0_TX/ EPPIO_D12/ SMCO_A11/TMO_ACIO	U45	Low
7	Not Used					

Table 2-9. Output Signals of Microchip GPIO Expander (U38 Port B)

Bit	Signal Name	Description	FET/ SWITCH	Processor Signal (if applicable)	Component Connected	Default
0	Not Used					
1	Not Used					
2	LED1_GPIO1_EN	Enables LED1	U23	PA_00/SPI1_CLK/ TRACE0_D07/ SMCO_ABE0	U2	Low
3	LED2_GPIO2_EN	Enables LED2	U24	PA_01/ SPI1_MISO/ TRACE0_D06/ SMCO_ABE1	U2	Low
4	LED3_GPIO3_EN	Enables LED3	U25	PB_01/ EPPIO_D06/ SPT1_BFS/ SPI0_MI-SO/ SMCO_D06/ TMO_AC11	U2	Low
5	PUSHBUTTON1_EN	Enables push button 1	U21	PA_02/ SPI1_MOSI/ TRACE0_D05/ SMCO_AMS1	SW4	Low

ADSP-BF707 EZ-KIT Lite Hardware Reference

Table 2-9. Output Signals of Microchip GPIO Expander
(U38 Port B) (Cont'd)

Bit	Signal Name	Description	FET/ SWITCH	Processor Signal (if applicable)	Component Connected	Default
6	PUSHBUTTON2_EN	Enables push button 2	U22	PB_07/ EPPI0_D00/ SPT0_BD1/ SPI0_D3/ SMCO_D00/ SYS_WAKE0	SW3	Low
7	Not Used					

Push Buttons and Switches

This section describes operation of the push buttons and switches. The push button and switch locations are shown in [Figure 2-6](#).

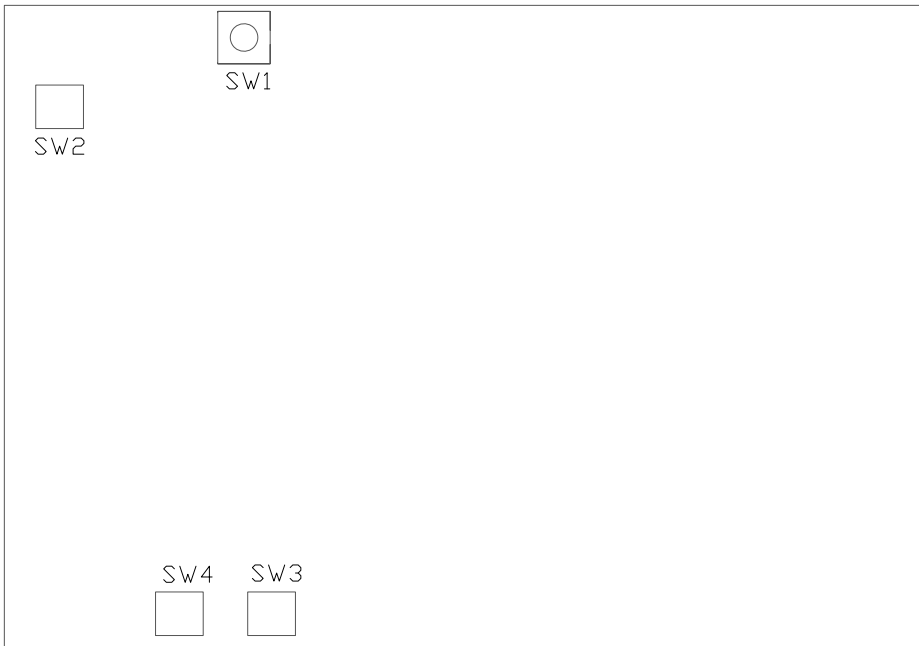

Figure 2-6. Push Button and Boot Mode Switch Locations

Boot Mode Select Switch (SW1)

The rotary switch (SW1) determines the boot mode of the processor. [Table 2-10](#) shows the available boot mode settings. By default, the ADSP-BF707 processor boots from the internal SPI flash memory.

Table 2-10. Boot Mode Select Switch (SW1)

SW1 Position	Processor Boot Mode
0	No Boot – Idle
1	SPI master boot (SP12). Default boot mode.
2	SPI slave boot (SPI2)
3	UART boot (UART0)

Reset Push Button (SW2)

The reset push button (SW2) resets the following ICs: processor (U1), GPIO extender (U39), and GPIO extender (U38). The reset also is connected to the expansion interface via the $\overline{\text{SYS_HWRST}}$ signal.

GPIO Push Buttons (SW3-4)

The GPIO push buttons (SW3 and SW4) are connected to the processor's signals PA_02/SPI1_MOSI/TRACE0_D05/ $\overline{\text{SMCO_AMSI}}$ and PB_07/EPPIO_D00/SPT0_BD1/SPI0_D3/SMCO_D00/SYS_WAKE0, respectively. The signals are connected by default. A monostable pulse generator (one-shot, U49) on push button 2 shortens the wake pulse, allowing the processor to return to low power mode sooner.

Jumpers

This section describes functionality of the configuration jumpers. [Figure 2-7](#) shows the jumper locations.

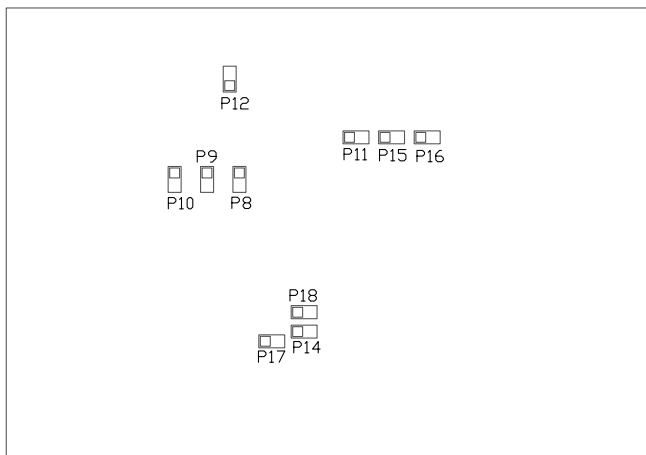

Figure 2-7. Jumper Locations

Power Jumpers (P8-12, P14-18)

Remove jumpers listed in [Table 2-11](#) to measure the respective voltage across the adjacent sense resistor.

Table 2-11. Power Jumpers

Power Jumper	Resistor
P8	VDD_INT
P9	3.3V
P10	VDD_EXT
P11	USB0_VBUS

Table 2-11. Power Jumpers (Cont'd)

Power Jumper	Resistor
P12	VDD_DMC0
P14	VDD_HADC
P15	VDD_OTP
P16	VDD_USB
P17	VDD_RTC
P18	HADC_VREFP (no sense resistor, remove to supply HADC_VREFP through J9)

LEDs

This section describes the on-board LEDs. [Figure 2-8](#) shows the LED locations.

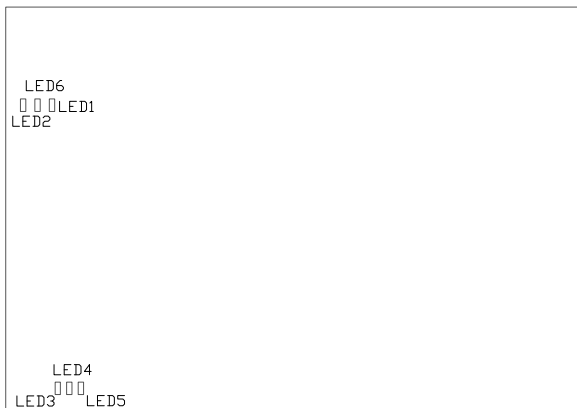

Figure 2-8. LED Locations

LEDs

GPIO LEDs (LED3–5)

Three LEDs are connected to the general-purpose I/O pins of the processor (see [Table 2-12](#)). The LEDs are active high and are ON (amber) by writing a 1 to the correct processor signal.

Table 2-12. GPIO LEDs

LED Reference Designator	Processor Programmable Flag Pin
LED3	PA_00
LED4	PA_01
LED5	PB_01

Reset LED (LED6)

When LED6 is ON (red), it indicates that the master reset of all the major ICs is active. The reset LED is controlled by the Analog Devices ADM6315 supervisory reset circuit. $\overline{\text{TARGET_RESET}}$ is a signal driven from an emulator. EI3 extender cards can also drive a reset as an input to this reset circuit. A master reset is asserted by pressing SW2 which activates LED6. For more information, see [Reset Push Button \(SW2\)](#).

Power LED (LED2)

When LED2 is ON (green), it indicates that power is being supplied to the board properly. For more information, see [Power Architecture](#).

SYS_FAULT LED (LED1)

When $\overline{\text{SYS_FAULT_LED}}$ (LED1) (red) is ON, it indicates a system fault. For more information, refer to the hardware reference manual.

Connectors

This section describes connector functionality and provides information about mating connectors. The connector locations are shown in [Figure 2-9](#).

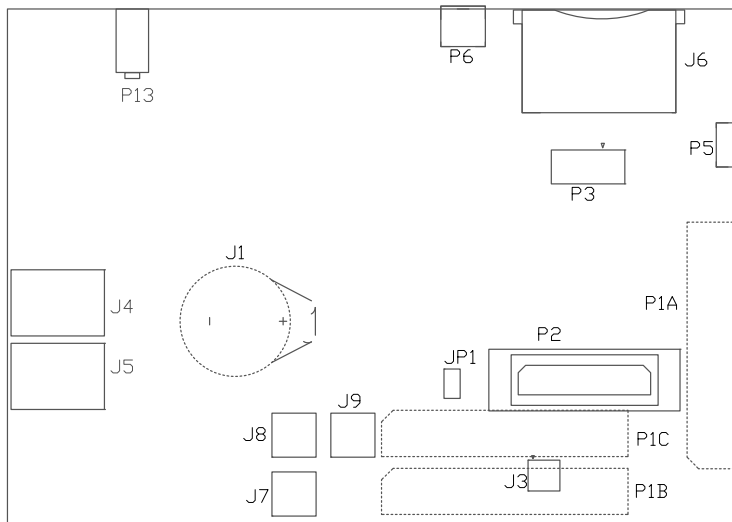

Figure 2-9. Connector Locations



Connectors on the back of the board are noted with dotted lines.

Connectors

Expansion Interface III Connectors (P1A-C)

Three board-to-board connectors (P1A, P1B, P1C) provide signals from the SPI, TWI, UART, SPORT, and GPIO interfaces of the processor. The connectors are located on the bottom side of the board.

For more information, see [Expansion Interface](#).

Part Description	Manufacturer	Part Number
120-pin, 0.6 mm	Hirose	FX8-120P-SV1(91)
Mating Cable		
120-pin, 0.6 mm	Hirose	FX8-120S-SV(21)

Power Connector (P13)

Part Description	Manufacturer	Part Number
0.65 mm power jack	CUI	045-0883R
Mating Cable		
5.0VDC@3.6A power supply	GLOBETEK	GS-1750(R)

USB to UART Connector (P6)

Part Description	Manufacturer	Part Number
USB Mini-B	Hirose	UX60SC-MB-5S8
Mating Cable		
USB Mini-B to Standard-A cable	Any	

USB Connector (P5)

Part Description	Manufacturer	Part Number
USB Micro-AB	Hirose	ZX62D-AB-5P8
Mating Cable		
USB Micro-B to Standard-A or Micro-A to Standard-A receptacle cable	Any	

RF Wireless Connector (J3)

Part Description	Manufacturer	Part Number
4x2 0.05" pitch socket	SAMTEC	SFMC-104-T2-S-D
Mating Connector		
4x2 0.05" pitch header	SAMTEC	FTSH-104-04-F-D

HADC SMC Connectors (J7, J8, J9)

J7 allows an input to the HADC_VIN2 signal of the processor. J8 allows an input to the HADC_VIN3 signal of the processor. J9 allows the HADC_VREFP signal to be injected if the P18 jumper is removed.

Part Description	Manufacturer	Part Number
SMC threaded	Amphenol	152119
Mating Cable		
SMC cable	Various	

Connectors

HADC Connector (JP1)

JP1 allows the VDD_RTC signal to be connected to HADC0_VIN0 with the installation of a jumper across pins 1 and 2. Pin 3 is not connected. Pin 4 allows the user to probe HADC0_VIN1 which is connected to an RC timer driven by TMO_TMR3 on PC_05.

Part Description	Manufacturer	Part Number
2x2 0.1" header	SAMTEC	TSM-102-01-T-DV
Mating Devices		
Jumper for pins 1 and 2, probe for pin 4		

SD Connector (J6)

Part Description	Manufacturer	Part Number
SD 8-bit, 2 GB	SANDISK	MHC-W21-601
Mating Card		
2 GB	SANDISK	SDSDB-2048-A11

CAN0 Connector (J4)

Part Description	Manufacturer	Part Number
RJ11 vertical	DIGIKEY	A31431-ND
Mating Cable		
RJ11 cable		

CAN1 Connector (J5)

Part Description	Manufacturer	Part Number
RJ11 vertical	DIGIKEY	A31431-ND
Mating Cable		
RJ11 cable		

JTAG/SWD/SWO Connector (P3)

The JTAG/SWD/SWO header (P3) provides debug connectivity for the processor. This is a 0.05” shrouded through-hole connector from SAMTEC (SHF-105-01-L-D-TH). This mates with ICE-1000, ICE-2000, and any newer ADI emulators. For more information, see [Debug Interface](#).

TRACE and JTAG/SWD/SWO Connector (P2)

The TRACE and JTAG/SWD/SWO Connector (P2) provides connectivity to the microprocessor’s trace interface. This is a MICTOR connector from TYCO (2-5767004-2). There are no trace pods available at this time. If one does become available, R162, R191, R192, and R193 need to be installed to connect P2.

Connectors

A ADSP-BF707 EZ-KIT LITE BILL OF MATERIALS

The bill of materials corresponds to [ADSP-BF707 EZ-KIT Lite Schematic](#).

Ref.	Qty.	Description	Reference Designator	Manufacturer	Part Number
1	3	SMC THREADED AMPHENOL_152119	J7-J9	AMPHENOL CONN	152119
2	1	ADP5024 QFN50P400X400-25N	VR1	ADI	ADP5024ACPZ-R2
3	1	ADM6315 SOT143	U37	ADI	ADM6315-29D2ARTZR7
4	1	ADSP-BF707 BGA184C80P14X14_1200X1200_SCKT	U1	ADI	ADSP-BF707BBCZ-ENG
5	1	10UF 6.3V 10% 0805 X5R	C124	AVX	08056D106KAT2A
6	43	0.1UF 10V 10% 0402 X5R	C1,C2,C5,C20-C22,C25,C26,C28-C32,C38,C40-C42,C47,C49,C50,C54,C66-C68,C74-C76,C78-C81,C95,C96,C125-C128,C142-C144,C146,C148,C152	AVX	0402ZD104KAT2A

Ref.	Qty.	Description	Reference Designator	Manufacturer	Part Number
7	56	0.01UF 16V 10% 0402 X7R	C3,C6-C19,C23,C33-C37,C43-C46,C51-C53,C56-C58,C60,C61,C65,C69,C73,C77,C97-C99,C102-C104,C106-C111,C123,C129,C139-C141,C147,C150	AVX	0402YC103KAT2A
8	3	4.7UF 25V 20% 0805 X5R	C24,C121,C122	AVX	0805ZD475KAT2A
9	1	4.7UF 6.3V 20% 0603	C145	AVX	06036D475MAT2A
10	4	100PF 50V 5% 0603 NPO	C62,C63,C70,C71	AVX	06035A101JAT2A
11	1	27PF 50V 5% 0402 NPO	C134	AVX	04025A270JAT2A
12	1	10UF 16V 10% 1210 X5R	C113	AVX	1210YD106KAT2A
13	2	1000PF 50V 5% 1206	C112,C114	AVX	12065A102JAT2A
14	1	ROTARY SWT027	SW1	COPAL	S-8110
15	2	1UF 16V 10% 0603 X5R	C82,C120	DIGI-KEY	399-5090-2-ND
16	2	MCP23017 QFN65P600X600-29 N	U38,U39	DIGI-KEY	MCP23017-E/ML-ND
17	1	USB 5PIN CON069	P6	DIGI-KEY	H11589CT-ND
18	2	1UF 16V 10% 0805 X7R	C115,C116	DIGI-KEY	399-1284-2-ND
19	1	GREEN LED_0603	LED2	DIGI-KEY	475-1409-2-ND
20	2	4700PF 2A FIL_N-FE61PT	FER7,FER8	DIGI-KEY	490-2554-2-ND
21	1	25MHZ OSC-CC200X250	U36	DIGI-KEY	478-4780-1-ND

ADSP-BF707 EZ-KIT Lite Bill Of Materials

Ref.	Qty.	Description	Reference Designator	Manufacturer	Part Number
22	1	FT232RQ QFN50P500X500-33 NA	U45	DIGI-KEY	768-1008-1-ND
23	1	24MHZ OSC- CC200X250	U35	DIGI-KEY	478-4778-1-ND
24	1	USB-MICRO 5PIN HIROSE_ZX- 62D-AB-5P8	P5	DIGI-KEY	H11494CT-ND
25	1	30A GSOT05 SOT23-3	D2	DIGI-KEY	GSOT05-E3-08TR-ND
26	2	RED LED_0603	LED1,LED6	DIGI-KEY	475-2512-2-ND
27	3	YELLOW LED_0603	LED3-LED5	DIGI-KEY	475-2558-1-ND
28	2	15KV ESDA5V3SC6 SOT95P280-6N	D3,D4	DIGI-KEY	497-6633-1-ND
29	1	MIC2025-1 SOIC8	U40	DIGI-KEY	576-1057-ND
30	1	32.768KHZ OSC_ABS07L	Y3	DIGI-KEY	535-9542-2-ND
31	1	INA3221 QFN65P400X400-17 N	U48	DIGI-KEY	296-30459-1-ND
32	1	INA230 QFN50P300X300-17 N	U31	DIGI-KEY	296-30346-2-ND
33	5	IDC 2PIN_- JUMPER_SHORT	SJ1-SJ5	DIGI-KEY	S9001-ND
34	1	PWR .65MM CON045	P13	DIGI-KEY	CP1-023-ND
35	1	150UF 10V 10% D TANT-LOW-ESR	CT1	DIGI-KEY	478-3321-2-ND
36	2	4700PF 16V 10% 0603 X7R	C64,C72	DIGI-KEY	311-1083-2-ND

Ref.	Qty.	Description	Reference Designator	Manufacturer	Part Number
37	1	750.0K 1/10W 1% 0603	R179	DIGI-KEY	311-750KHRTR-ND
38	2	100 1/16W 5% 0402	R73,R74	DIGI-KEY	311-100JRTR-ND
39	1	12.0K 1/16W 1% 0402	R116	DIGI-KEY	311-12.0KLRCT-ND
40	6	330.0 1/16W 1% 0402	R4,R62,R80-R83	DIGI-KEY	541-330LCT-ND
41	2	10.0K 1/16W 1% 0402	R113,R118	DIGI-KEY	541-10.0KLCT-ND
42	8	100K 1/16W 5% 0402	R180-R187	DIGI-KEY	541-100KJTR-ND
43	2	15PF 50V 5% 0402 NPO	C132,C133	DIGI-KEY	399-1014-2-ND
44	1	100.0 1/16W 1% 0402	R21	DIGI-KEY	541-100LCT-ND
45	1	15.0K 1/16W 1% 0402 ZZZ	R119	DIGI-KEY	311-15.0KLRTR-ND
46	1	56.0K 1/16W 1% 0402	R101	DIGI-KEY	311-56.0KLRTR-ND
47	1	1UH 30% IND_LQH32P	L1	DIGI-KEY	490-5334-1-ND
48	1	1UH 30% INDC2016	L2	DIGI-KEY	490-7784-2-ND
49	1	20MA MA3X717E DIO005	D1	DIODES INC	BAS70-05-7-F
50	10	IDC 2X1 IDC2X1	P8-P12,P14-P18	FCI	90726-402HLF
51	3	0.6MM 120PIN HIROSE_FX8-120P-SV1(91)	P1A,P1B,P1C	HIROSE	FX8-120P-SV1(91)
52	1	IDT74FCT3244APY SSOP20	U2	IDT	IDT74FCT3244APYG
53	1	TEST LOOP LOOP_2838	GP1	KEYSTONE	5016

ADSP-BF707 EZ-KIT Lite Bill Of Materials

Ref.	Qty.	Description	Reference Designator	Manufacturer	Part Number
54	1	LTC6993-1 SOT95P280-6N	U49	LINEAR TECHNOLOGY	LTC6993CS6-1#TRMPBF
55	1	VARISTOR V5.5MLA 30A 0603	R1	LITTLEFUSE	V5.5MLA0603
56	1	PTC 0.5A 1206	R161	LITTLEFUSE	1206L050-C
57	1	BATT_HOLDERS 16MM BATT_- COIN16MM	J1	MEMORY PROTECTION DEVICES	BH600
58	1	MT47H128M16 FBGA84	U32	MICRON	MT47H128M16RT-25E XIT:C
59	1	SD_CONN 8-BIT CON067	J6	MORETHANALL	MHC-W21-601-LF
60	10	10UF 6.3V 20% 0603 X5R	C4,C27,C39,C48,C55, C59,C117-C119,C149	MULTICOMP	MCCA000517
61	1	190 5A FER002	FER6	MURATA	DLW5BSN191SQ2
62	2	1UF 6.3V 20% 0402 X5R	C100,C101	MURATA	GRM155R60J105ME19D
63	2	TJA1041 SOIC14	U46,U47	NXP	TJA1041T/CM,118
64	1	5A MBRS540T3G SMC	D7	ON SEMI	MBRS540T3G
65	2	15KV ESD7004 DFN50P250X100-10 N	D5,D6	ON SEMI	ESD7004MUTAG
66	3	MOMENTARY SWT024	SW2-SW4	PANASONIC	EVQ-Q2K03W
67	13	0 1/10W 5% 0402	R24,R102,R104,R115, R135,R136,R145,R146 ,R162,R176,R191-R19 3	PANASONIC	ERJ-2GE0R00X
68	16	0 1/10W 5% 0402	R2,R3,R10,R13,R15,R 25,R61,R111,R114,R1 31,R132,R140,R175,R 177,R188,R189	PANASONIC	ERJ-2GE0R00X

Ref.	Qty.	Description	Reference Designator	Manufacturer	Part Number
69	4	0.1 1/10W 1% 0603	R169-R172	PANASONIC	ERJ-3RSFR10V
70	2	1.0K 1/16W 1% 0402	R19,R20	PANASONIC	ERJ-2RKF1001X
71	1	33 1/16W 5% RNS003	RN1	PANASONIC	EXB-2HV330JV
72	2	2.2K 1/10W 5% 0402	R8,R9	PANASONIC	ERJ-2GEJ222X
73	4	60.4 1/10W 1% 0603	R26,R32,R34,R40	PANASONIC	ERJ-3EKF60R4V
74	1	39.0K 1/10W 1% 0402 ZZZ	R117	PANASONIC	ERJ-2RKF3902X
75	1	0.0 1/10W 1% 0603	R190	PHYCOMP	232270296001L
76	1	IDC 2x2 IDC2X2_SMT	JP1	SAMTEC	TSM-102-01-T-DV
77	1	IDC 4x2 SAMTEC_S- FMC-104-T2-S-D	J3	SAMTEC	SFMC-104-T2-S-D
78	1	0.05 10PIN SAM- TEC_SHF-105-01-L- D-TH	P3	SAMTEC	SHF-105-01-L-D-TH-TR
79	5	0.051 1/2W 1% 1206	R92,R105,R106,R112, R120	SEI	CSF 1/2 0.05 1%R
80	5	600 500MA 1206	FER1-FER5	STEWARD	HZ1206B601R-10
81	1	74LVC14A SOIC14	U30	TI	74LVC14AD
82	2	SN74LVC1G08 SOT23-5	U42,U44	TI	SN74LVC1G08DBVE
83	22	PI3A125 SC70_5	U3-U13,U21-U29,U50 ,U51	TI	SN74CBTLV1G125DCKR
84	1	MICTOR 38PIN CON015	P2	TYCO	2-5767004-2
85	2	RJ11 4PIN CON039	J4,J5	TYCO	5558872-1
86	1	3A RESETABLE FUS004	F1	TYCO	SMD300F-2
87	1	0 1/8W 5% 0805	R22	VISHAY	CRCW08050000Z0EA

ADSP-BF707 EZ-KIT Lite Bill Of Materials

Ref.	Qty.	Description	Reference Designator	Manufacturer	Part Number
88	18	10K 1/16W 5% 0402	R12,R28,R36,R44,R93,R94,R97,R107-R109,R151,R153,R154,R156,R158,R159,R168,R178	VISHAY	CRCW040210K0FKED
89	80	10K 1/16W 5% 0402	R5-R7,R11,R14,R16-R18,R29,R31,R33,R37,R39,R41-R43,R45-R52,R63-R65,R67,R70-R72,R77-R79,R84-R91,R95,R96,R98-R100,R103,R110,R122-R129,R134,R137-R139,R142-R144,R148-R150,R152,R155,R157,R160,R163-R167,R173,R174,R196,R197	VISHAY	CRCW040210K0FKED
90	6	33 1/16W 5% 0402	R68,R75,R121,R130,R133,R147	VISHAY	CRCW040233R0JNEA
91	1	10M 1/10W 5% 0603	R195	VISHAY	CRCW060310M0FNEA
92	2	1M 1/10W 5% 0603	R23,R194	VISHAY	CRCW06031M00FNEA
93	4	10 1/10W 5% 0603	R27,R30,R35,R38	VISHAY	CRCW060310R0JNEA
94	1	W25Q32 SO8W	U33	WINBOND	W25Q32FVSSIG

A

B

C

D

ADSP-BF707 EZ-Board SCHEMATIC

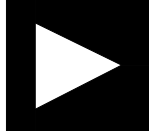
 ANALOG DEVICES		20 Cotton Road Nashua, NH 03063 PH: 1-800-ANALOGD	
Title		ADSP-BF707 EZ-BOARD Title	
Size C	Board No.	A0450-2013	Rev 1.0
Date	04/04/2014	Sheet	1 of 13

A

B

C

D

1

1

2

2

3

3

4

4

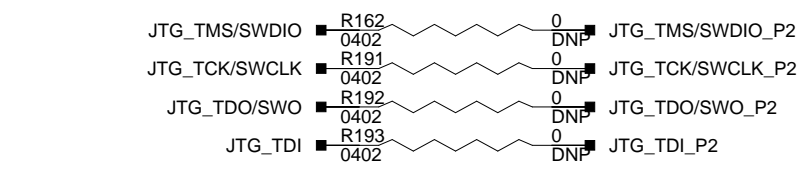
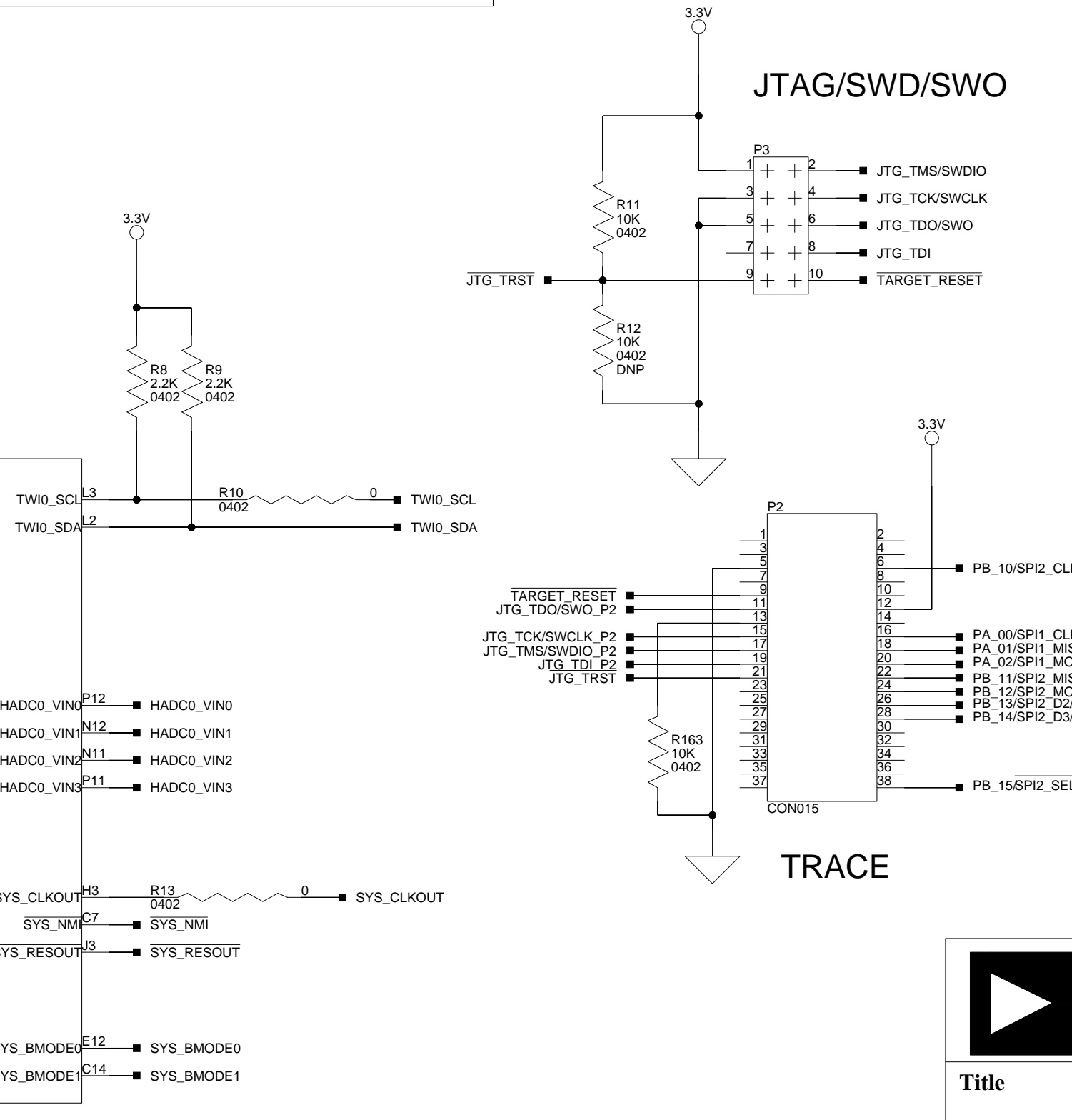
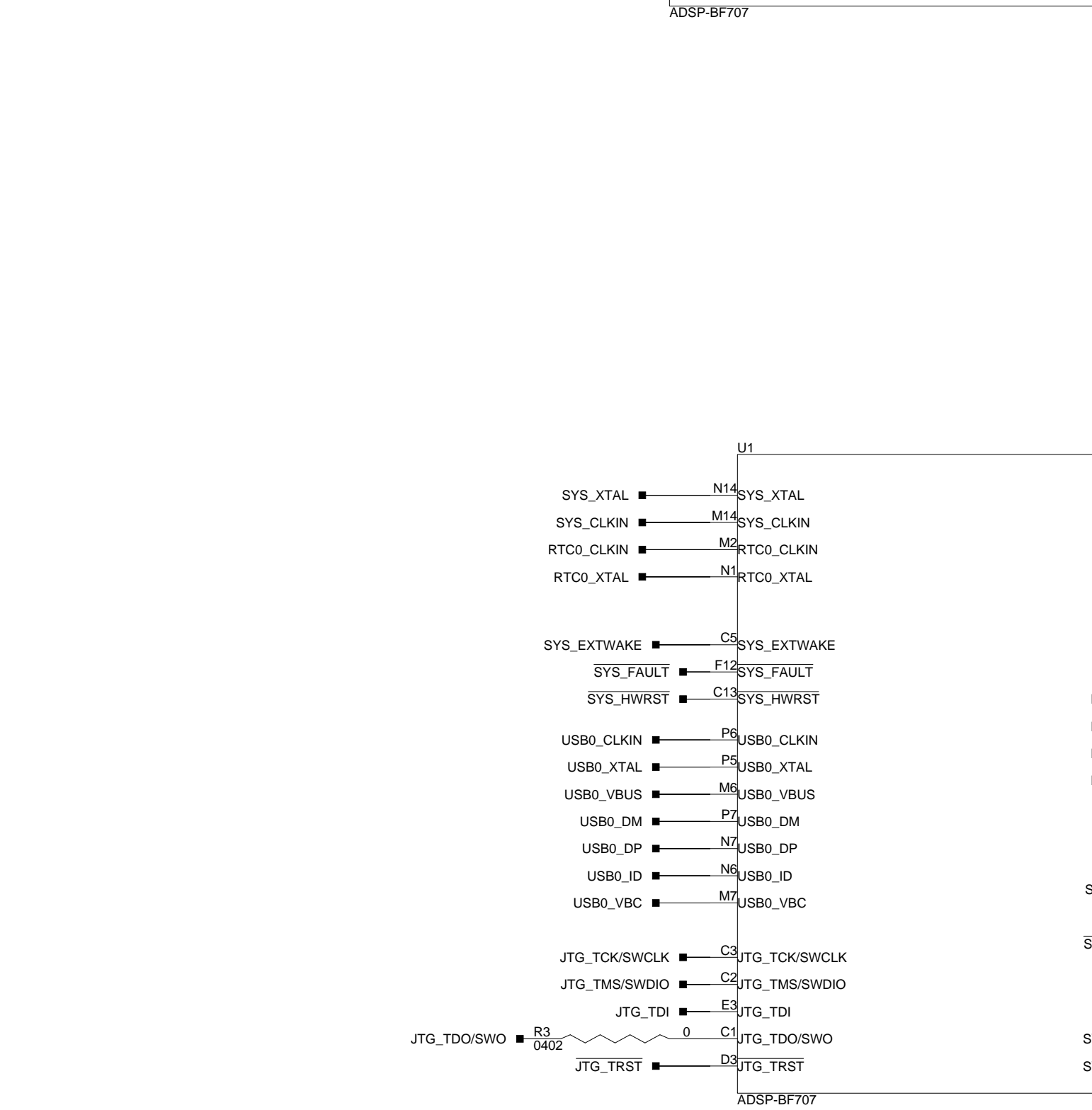
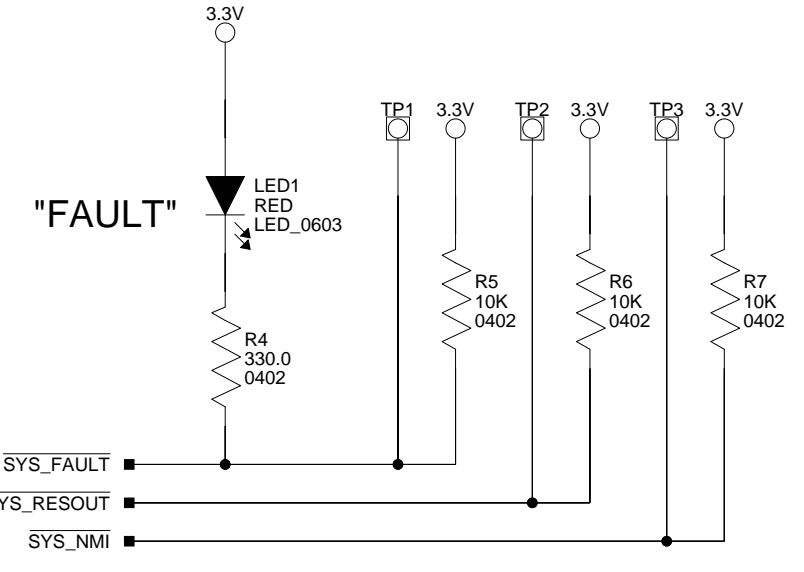
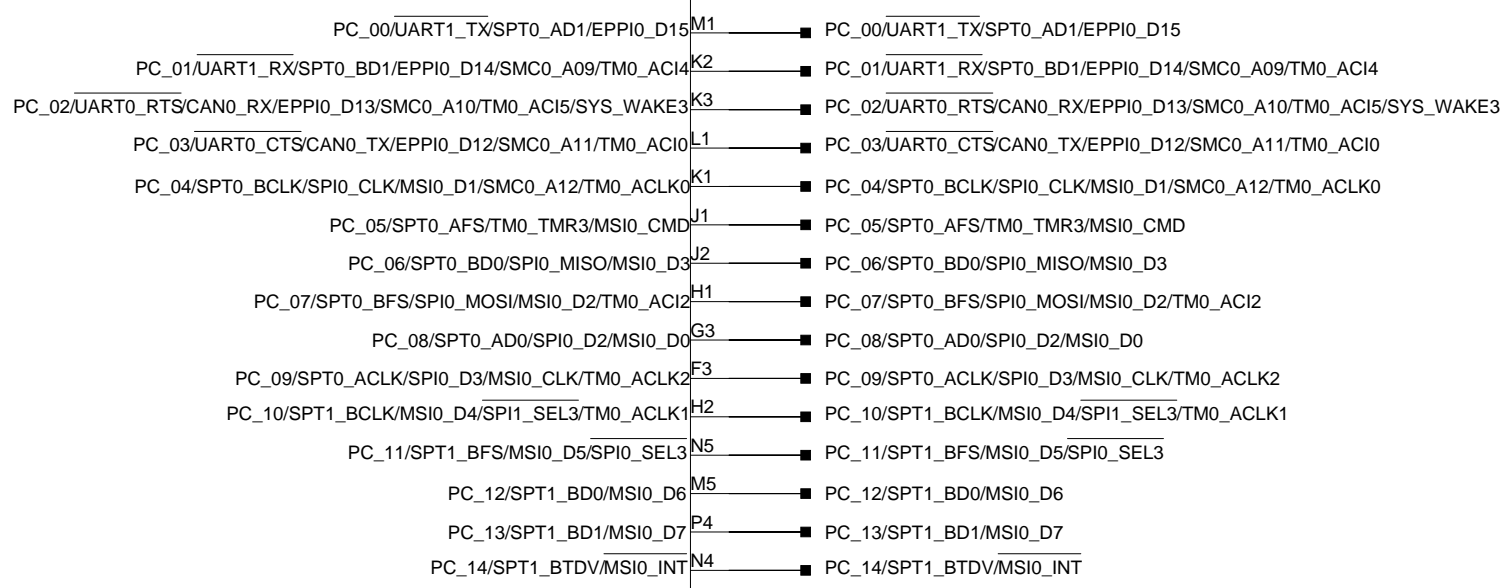
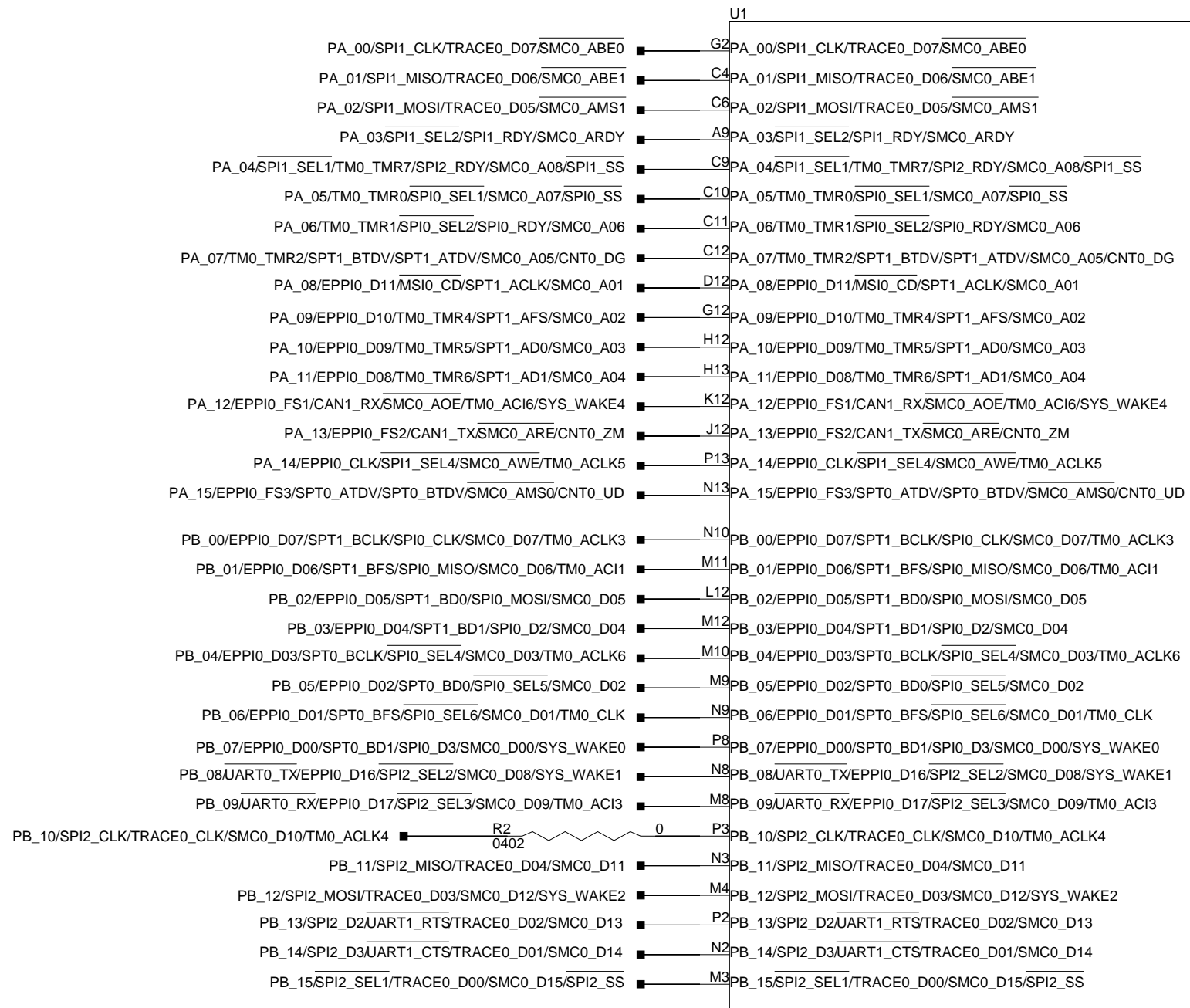

ANALOG DEVICES

20 Cotton Road
Nashua, NH 03063
PH: 1-800-ANALOGD

Title ADSP-BF707 EZ-BOARD Proc Ports, JTAG, Trace		
Size C	Board No. A0450-2013	Rev 1.0
Date 04/04/2014	Sheet 2 of 13	

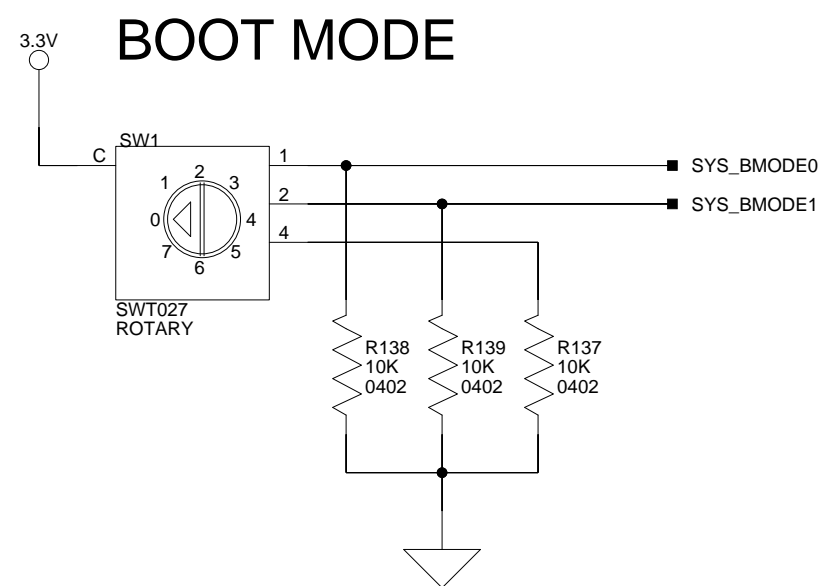
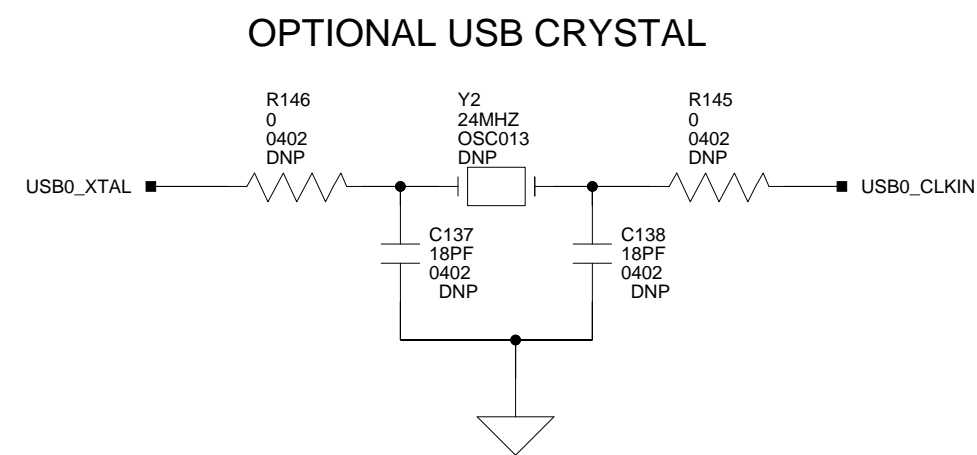
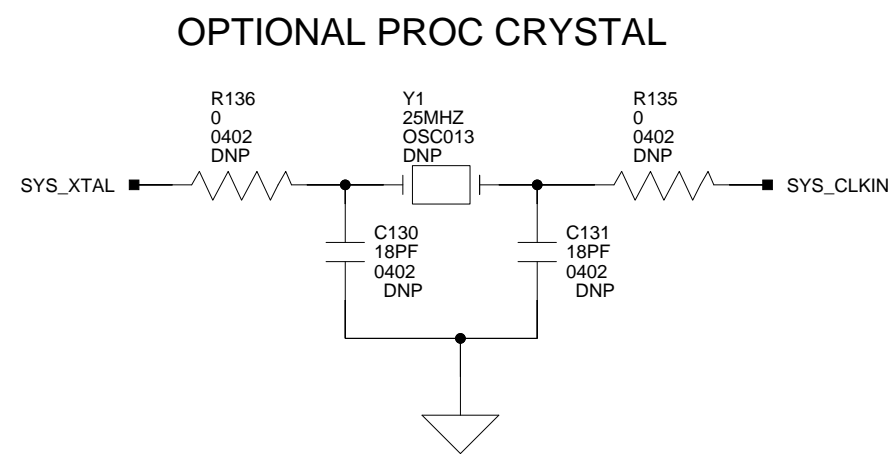
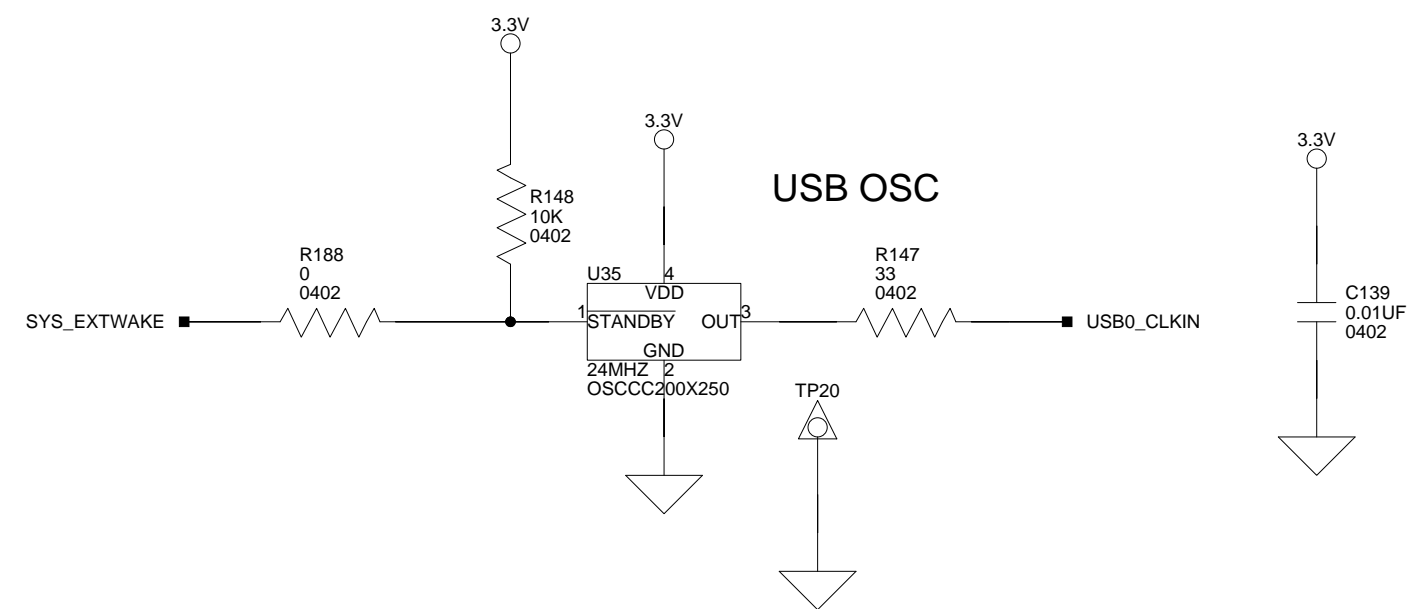
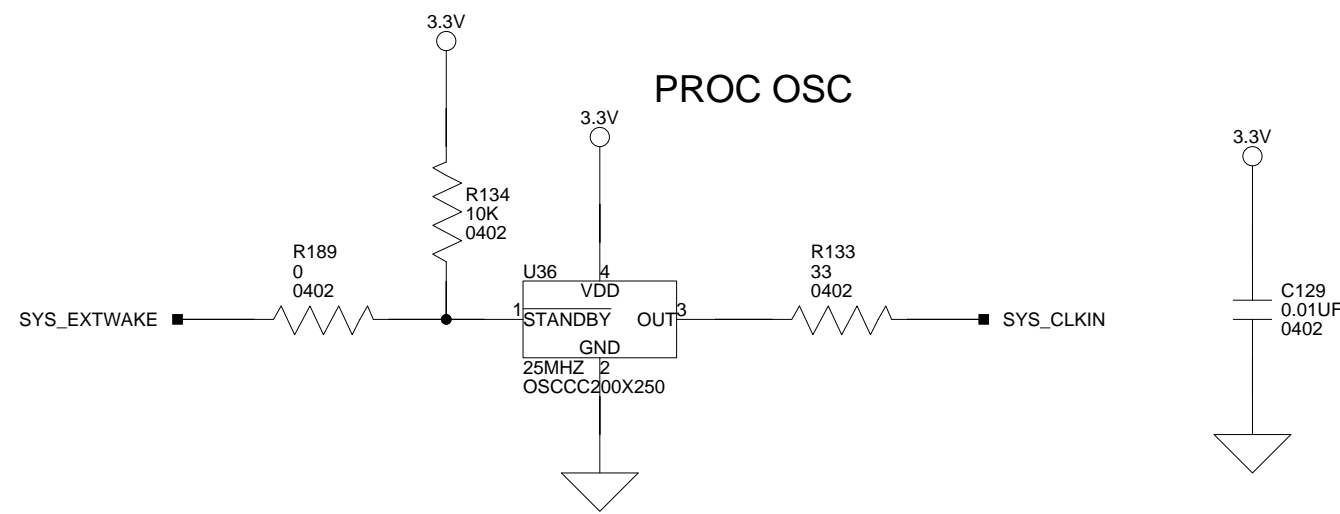

BOOT MODE SWITCH (SW1)

BOOT MODE (1:0)	
00	No Boot
01	SPI Master Boot (SPI2) DEFAULT
10	SPI Slave Boot (SPI2)
11	UART Boot (UART0)

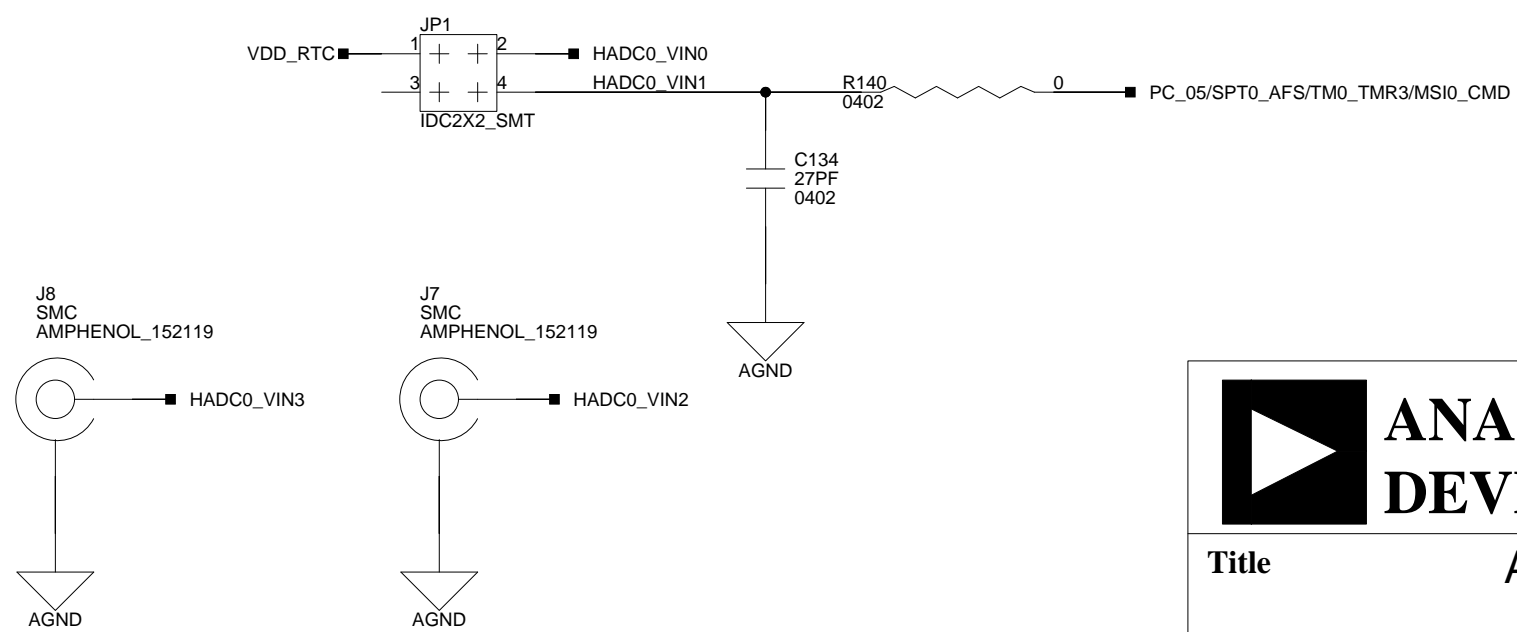
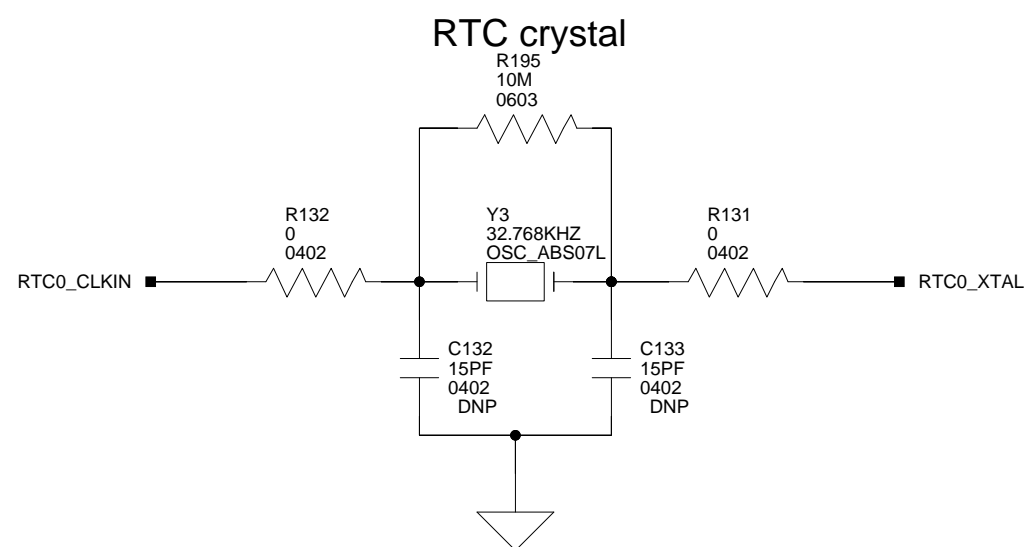

ANALOG DEVICES

20 Cotton Road
Nashua, NH 03063
PH: 1-800-ANALOGD

Title ADSP-BF707 EZ-BOARD Clocks, Boot Mode		
Size C	Board No. A0450-2013	Rev 1.0
Date 04/04/2014	Sheet 3 of 13	

DDR2 - 2Gb 16M x 16 x 8 banks

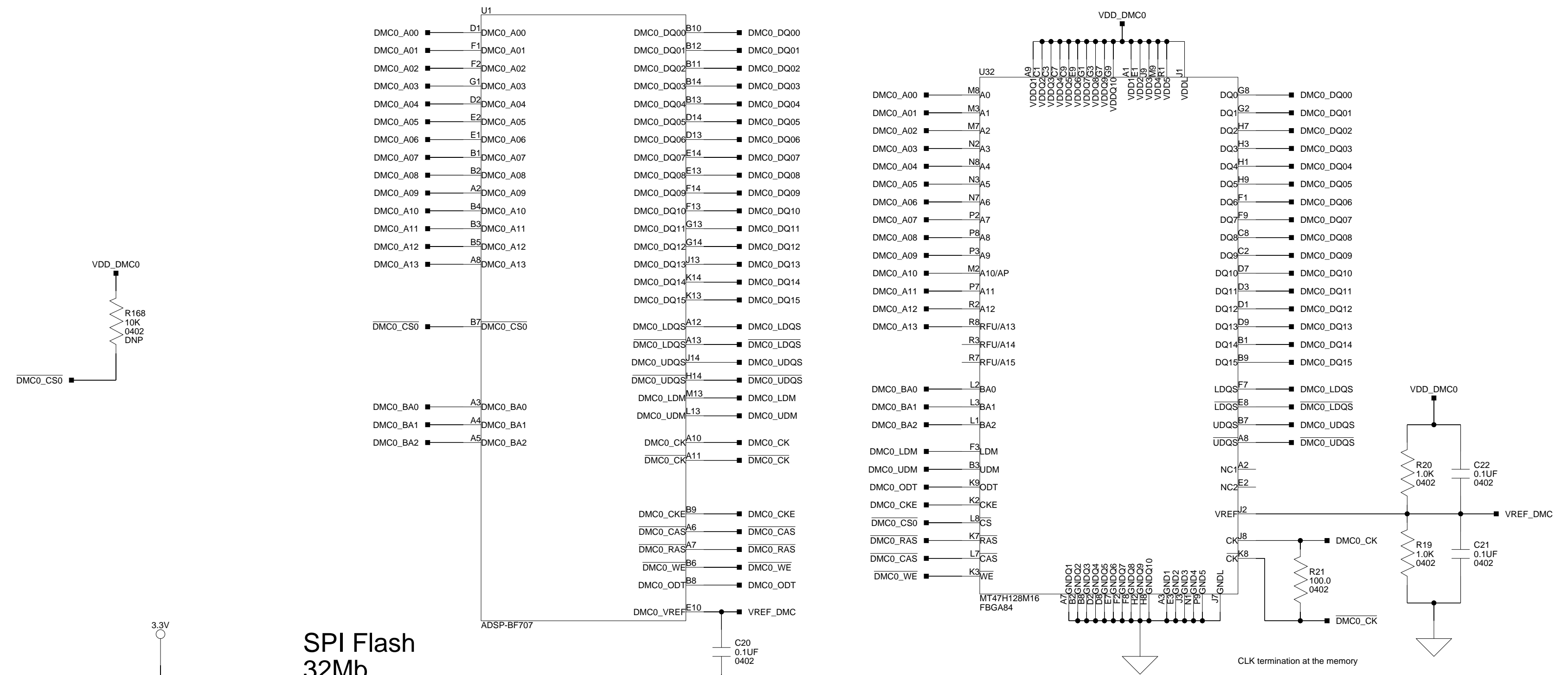

SPI Flash 32Mb

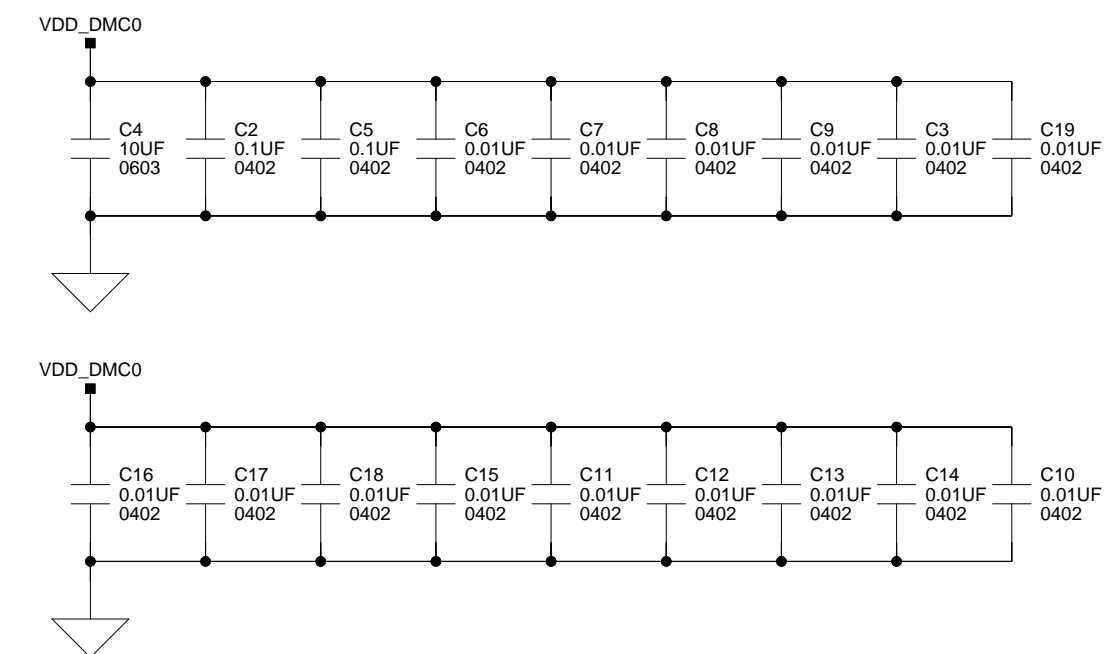
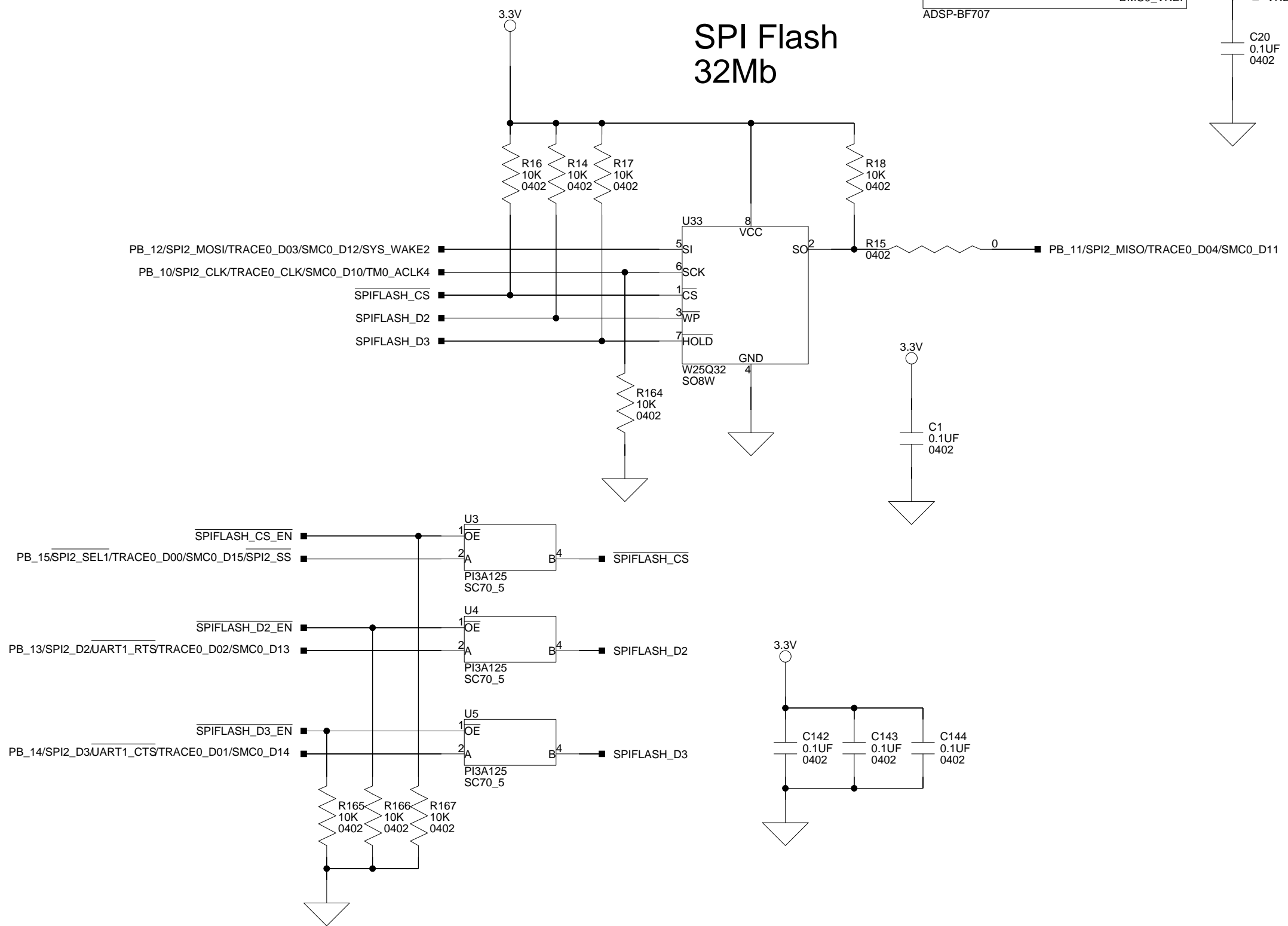

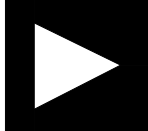
 ANALOG DEVICES		20 Cotton Road Nashua, NH 03063 PH: 1-800-ANALOGD	
		Title ADSP-BF707 EZ-BOARD Memory-DDR2, SPI Flash	
Size C	Board No. A0450-2013	Rev 1.0	
Date 04/04/2014	Sheet 4		of 13

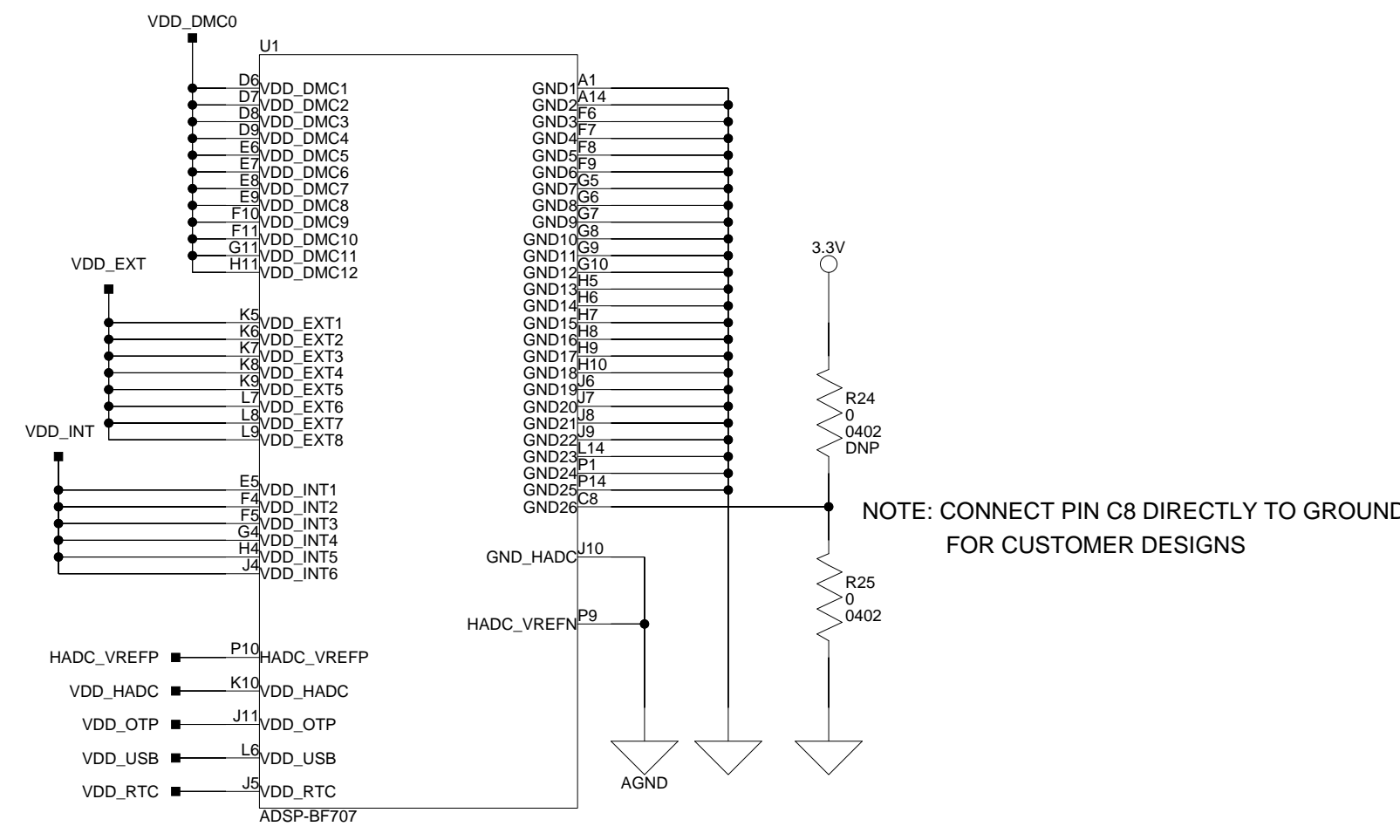

NOTE: CONNECT PIN C8 DIRECTLY TO GROUND FOR CUSTOMER DESIGNS

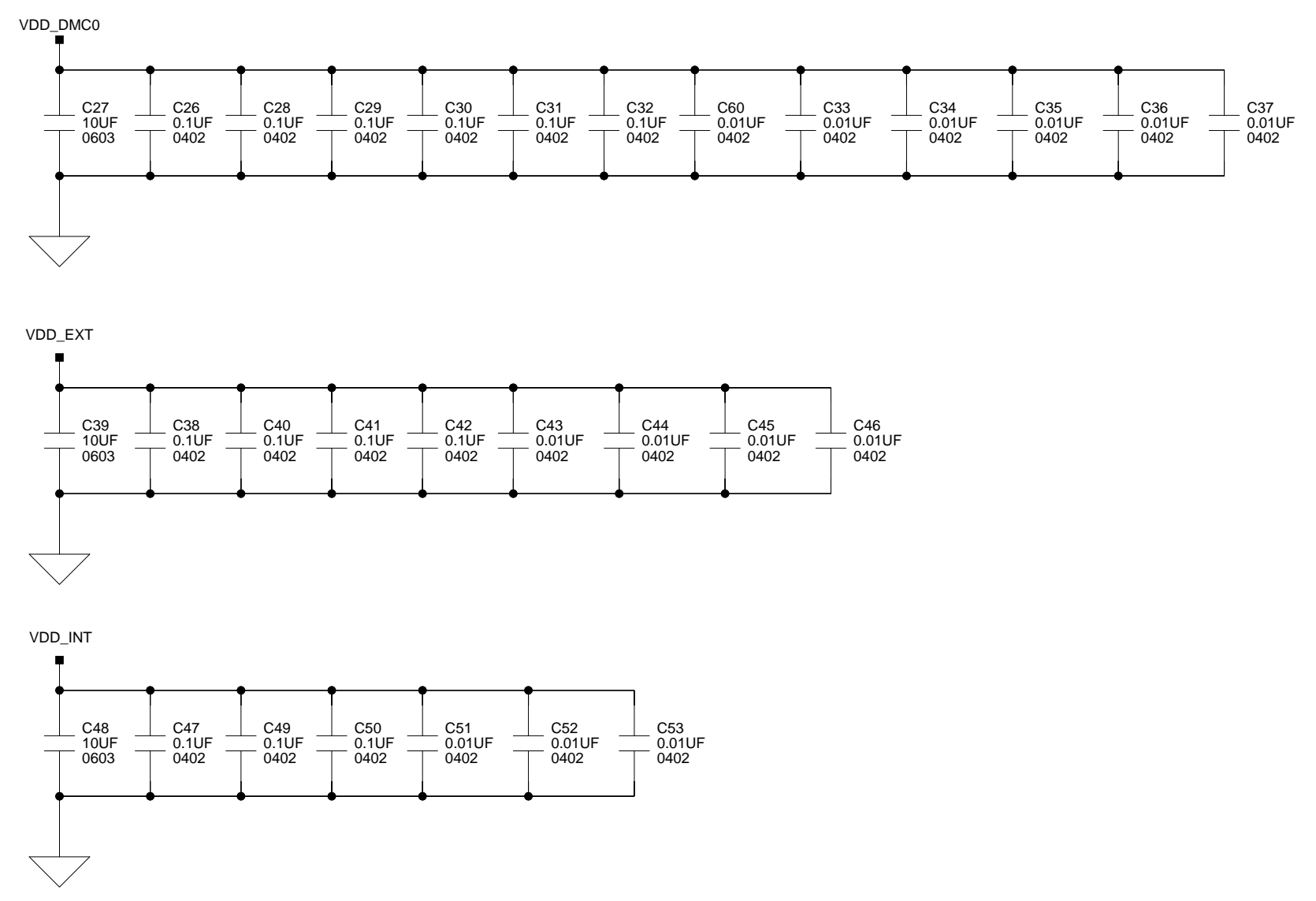
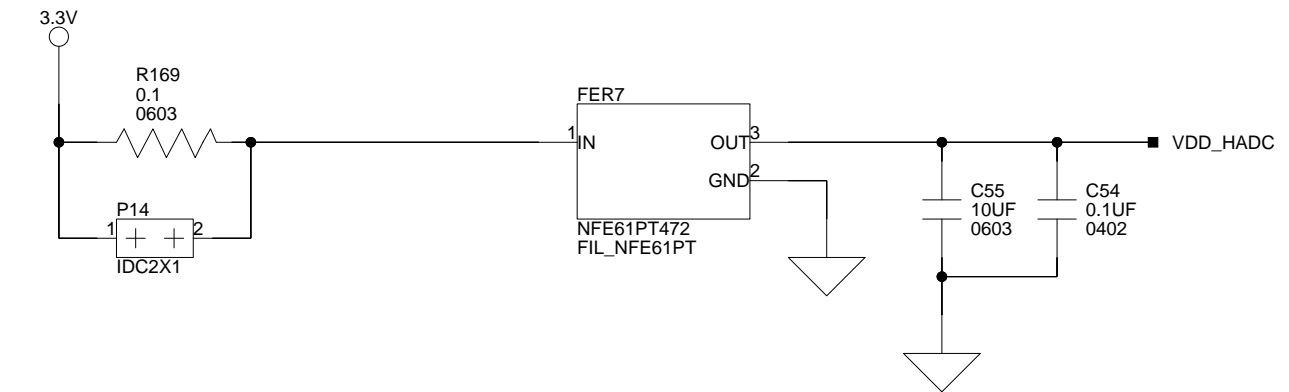
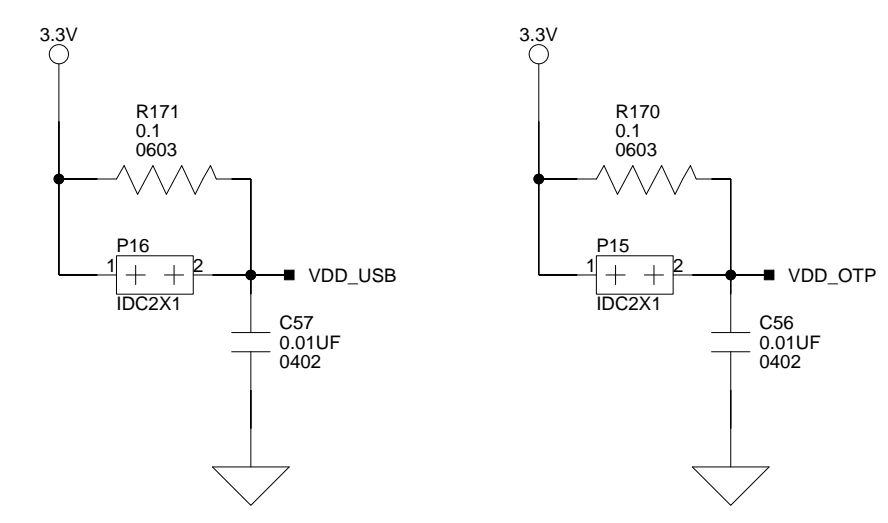
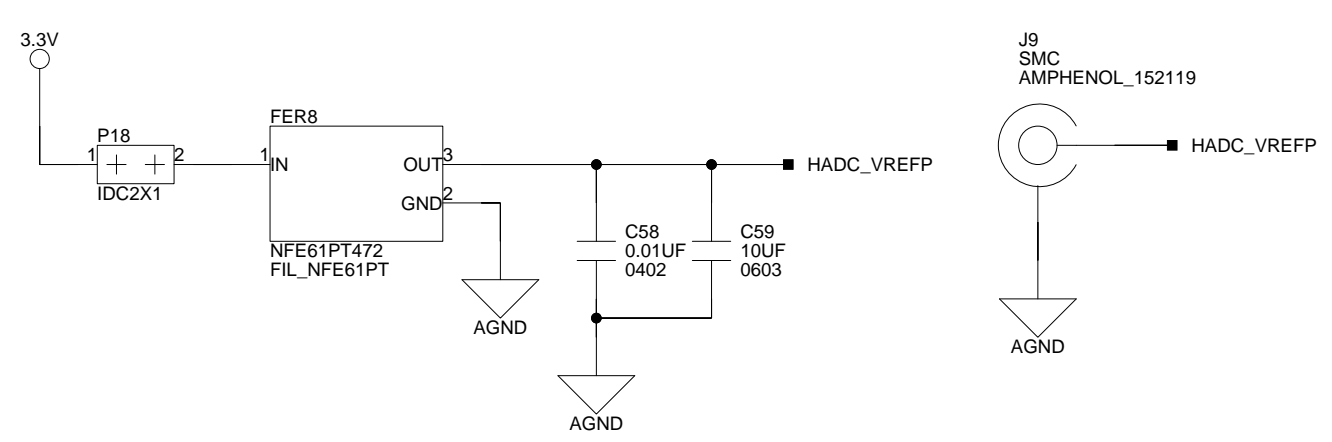
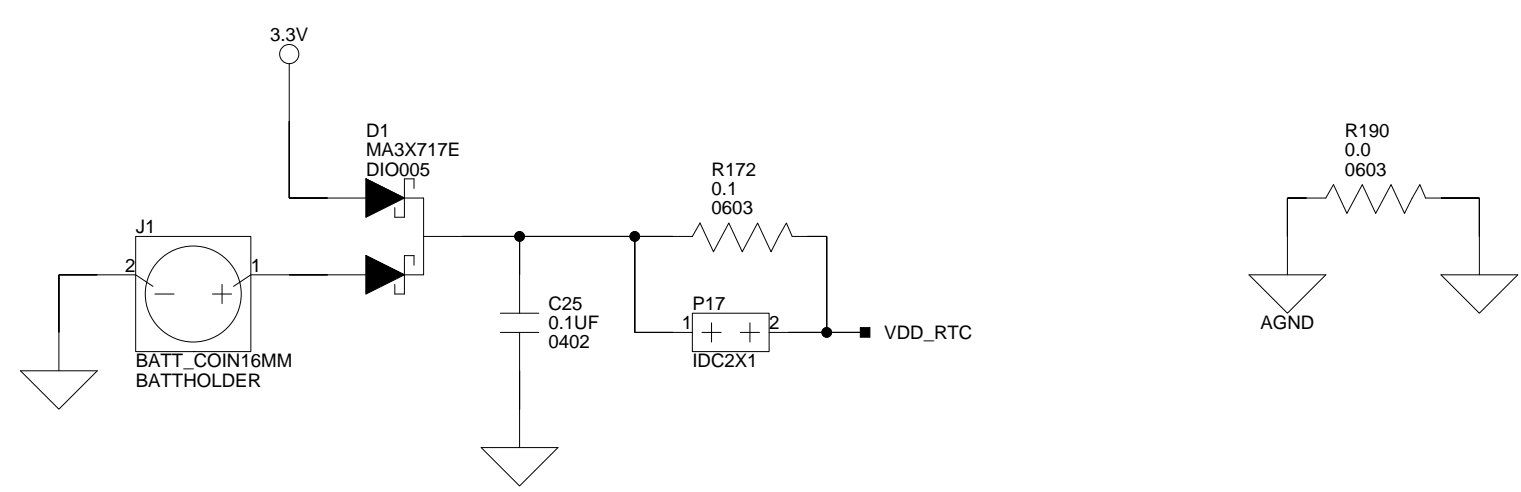
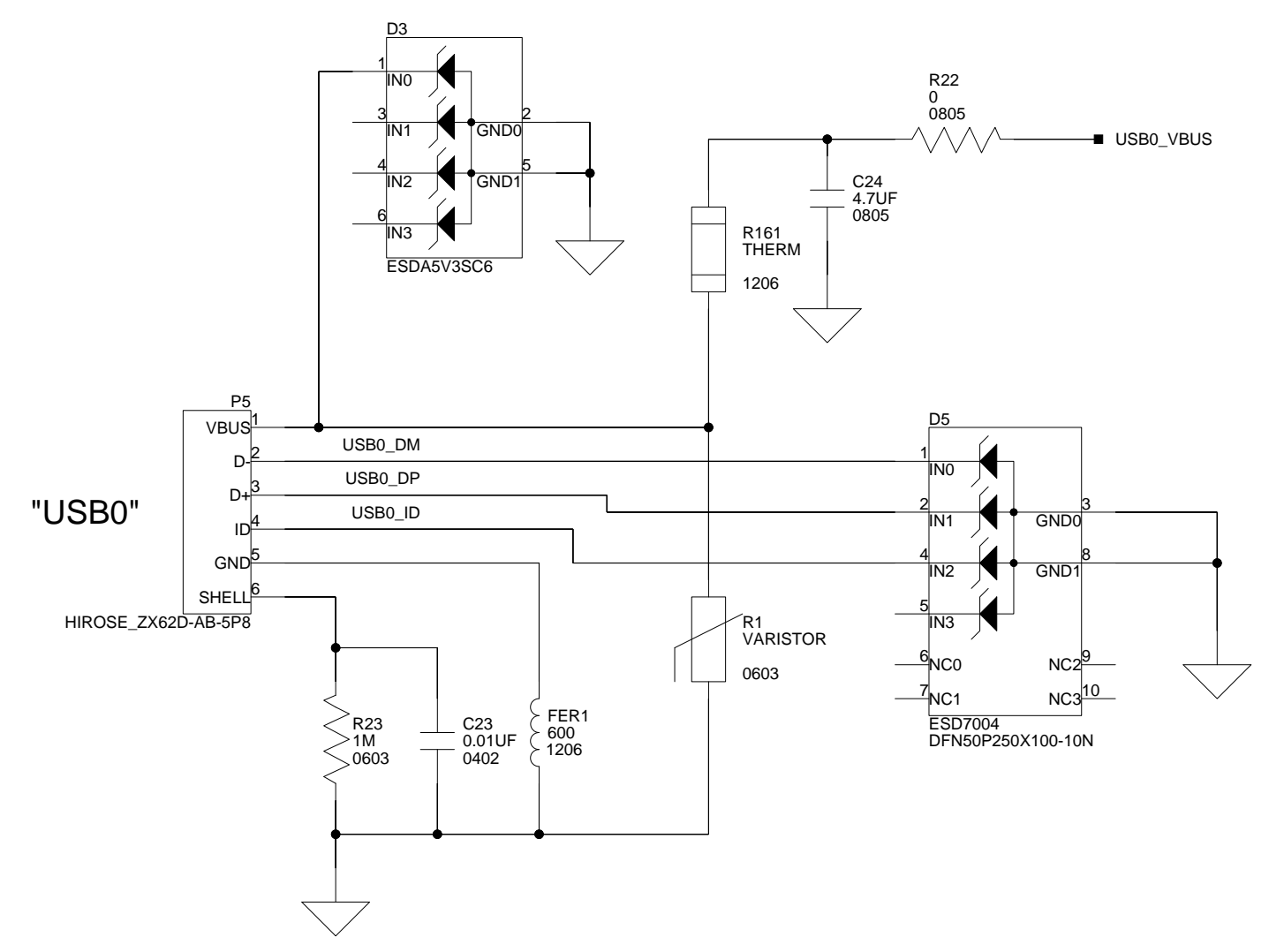

		20 Cotton Road Nashua, NH 03063 PH: 1-800-ANALOGD	
		Title ADSP-BF707 EZ-BOARD Proc Decoupling, USB0	
Size C	Board No. A0450-2013	Rev 1.0	
Date 04/04/2014	Sheet 5		of 13

RF Wireless

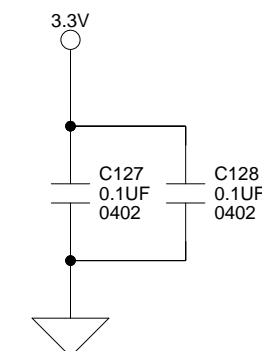
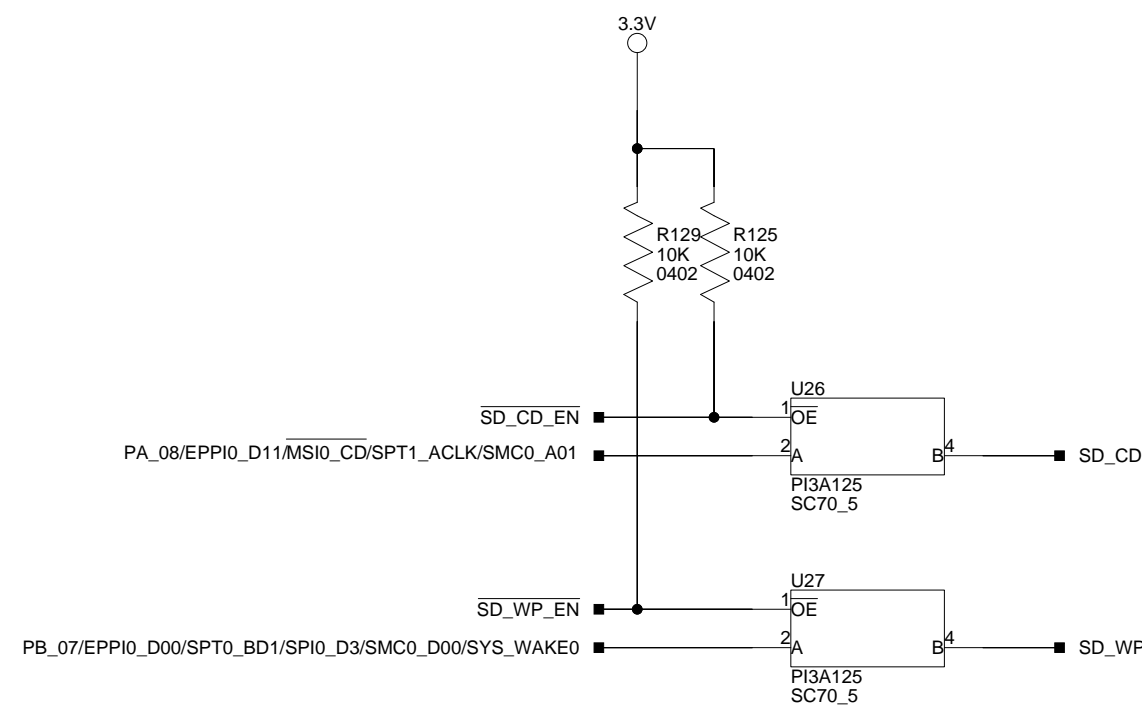
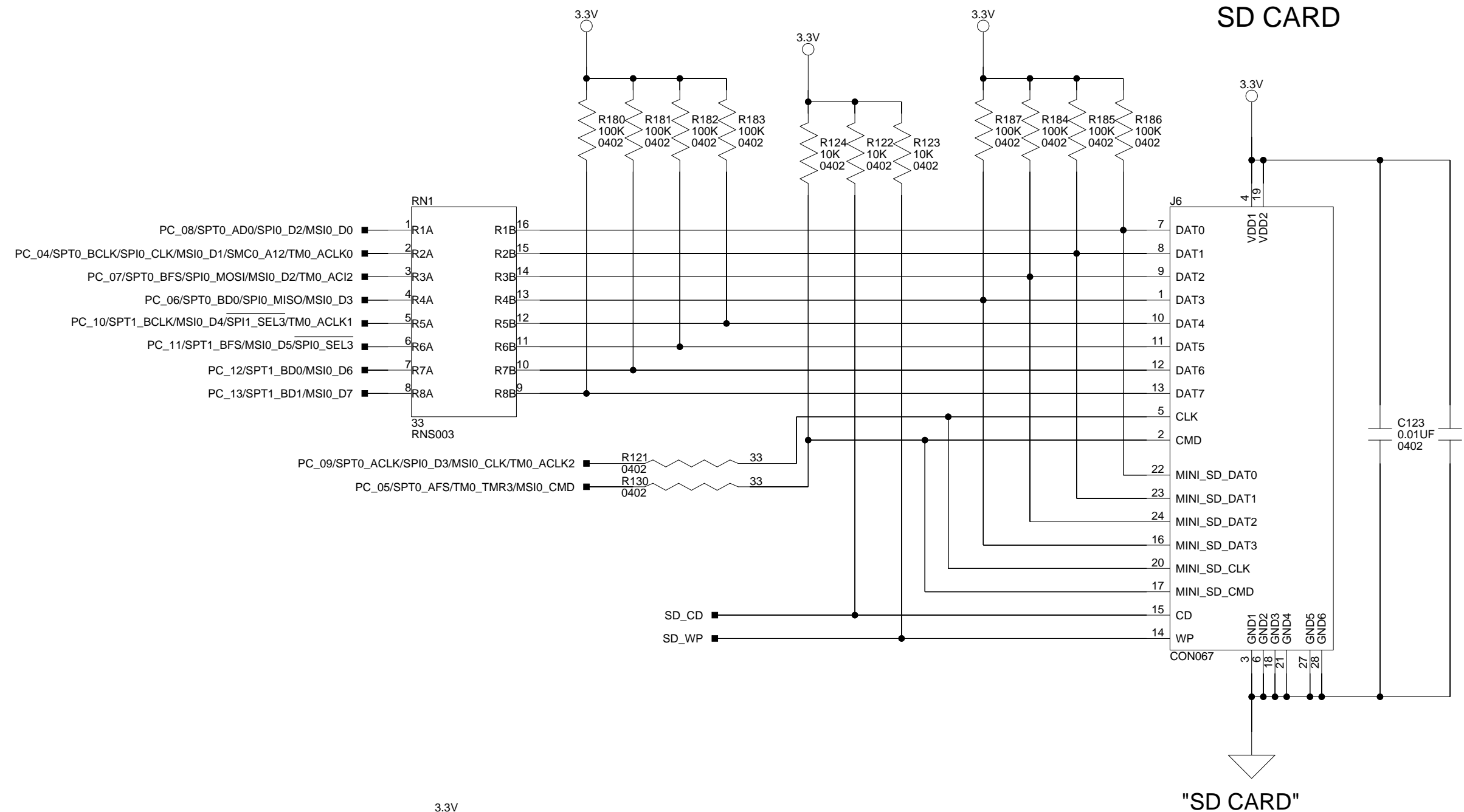
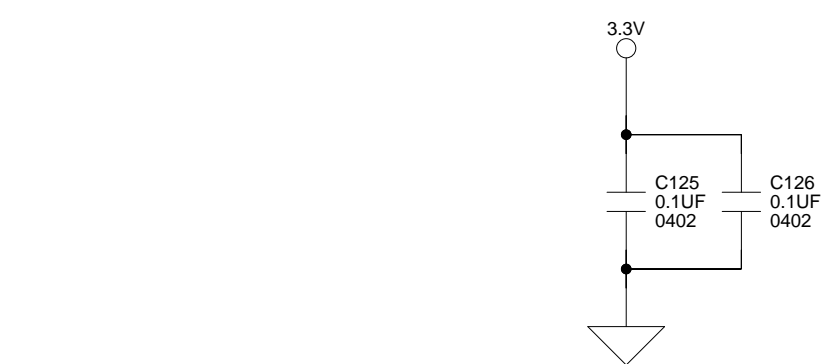
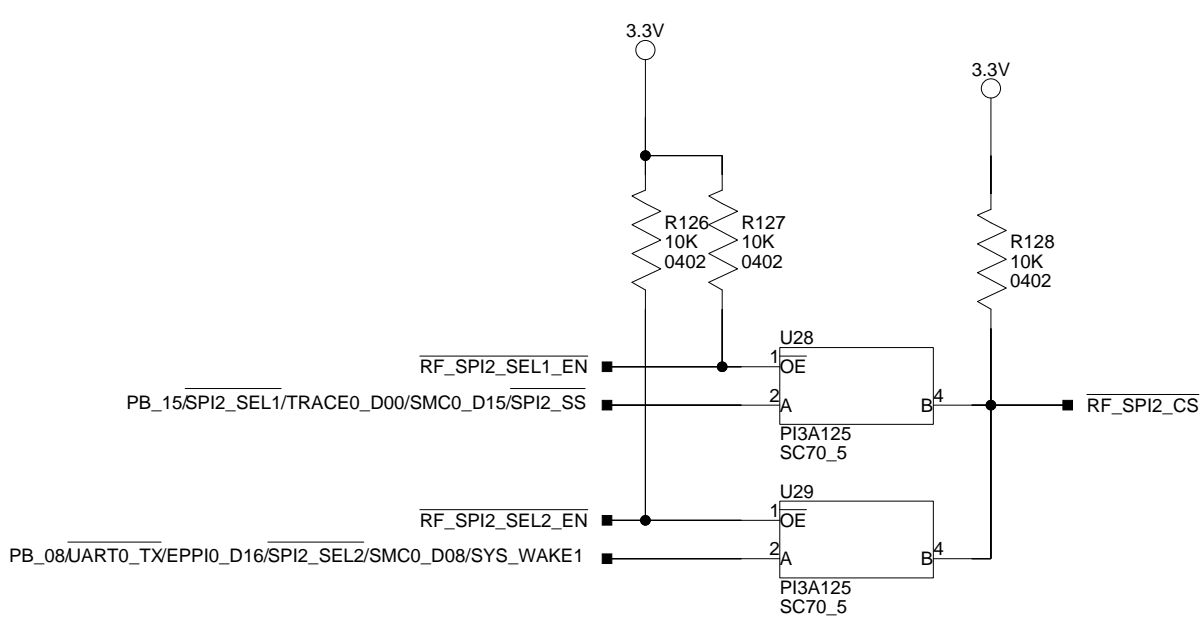
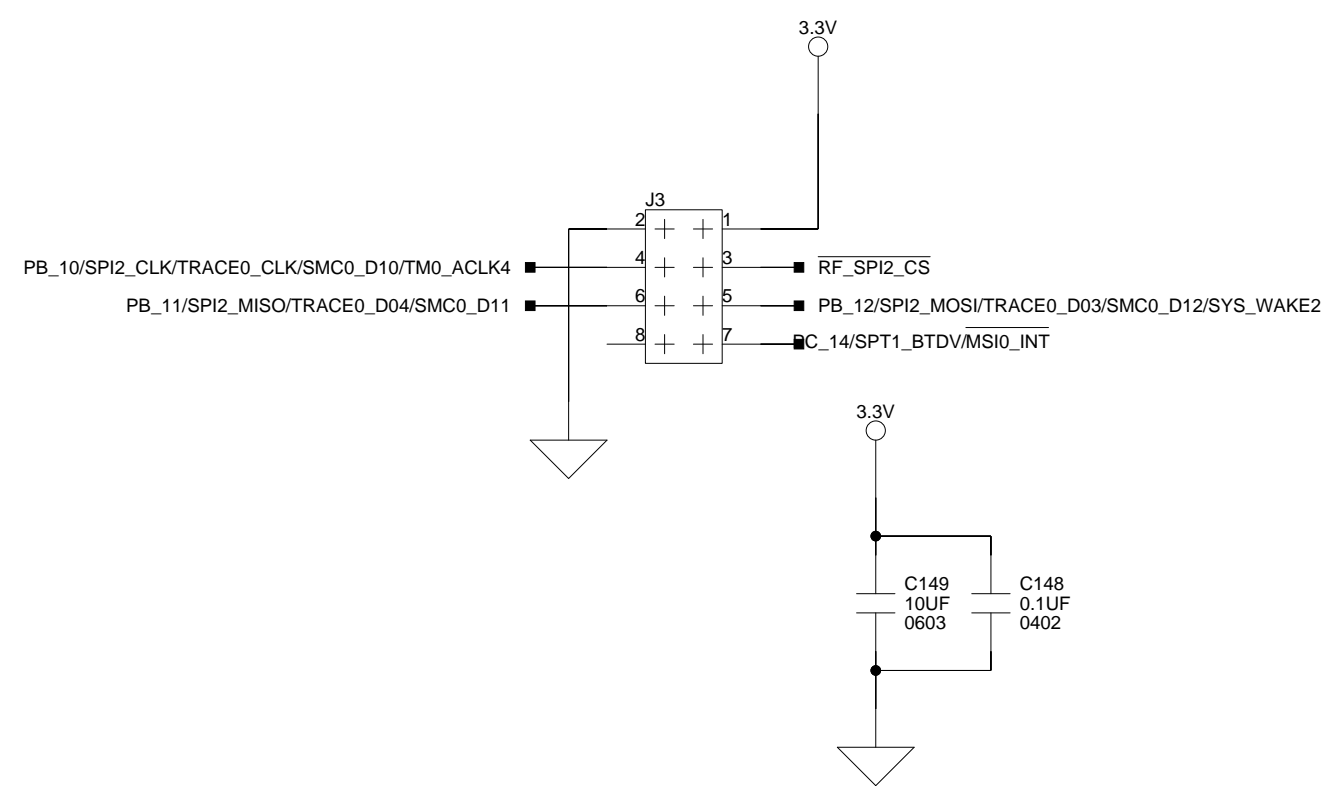

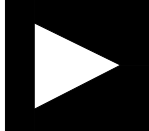
 ANALOG DEVICES		20 Cotton Road Nashua, NH 03063 PH: 1-800-ANALOGD	
		Title ADSP-BF707 EZ-BOARD RF Wireless, SD Conn	
Size C	Board No. A0450-2013	Rev 1.0	
Date 04/04/2014	Sheet 6		of 13

A

B

C

D

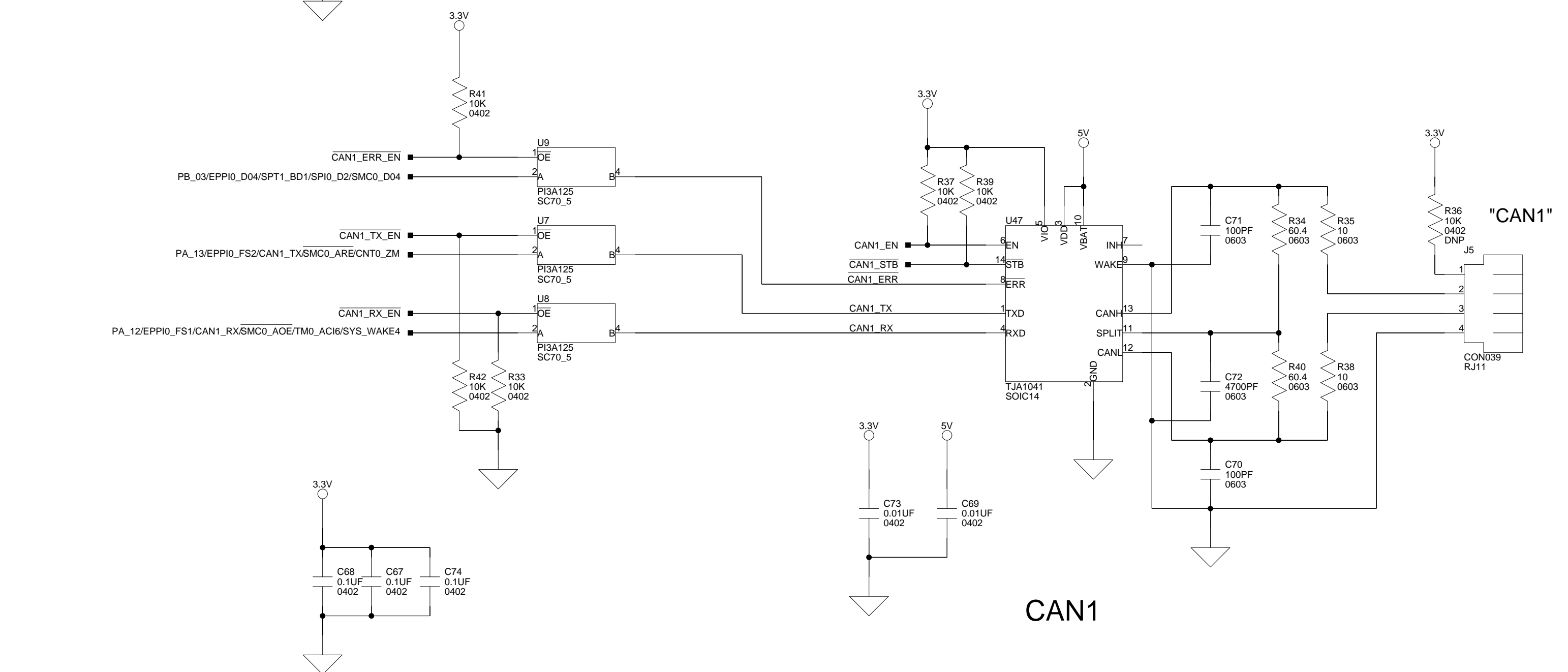
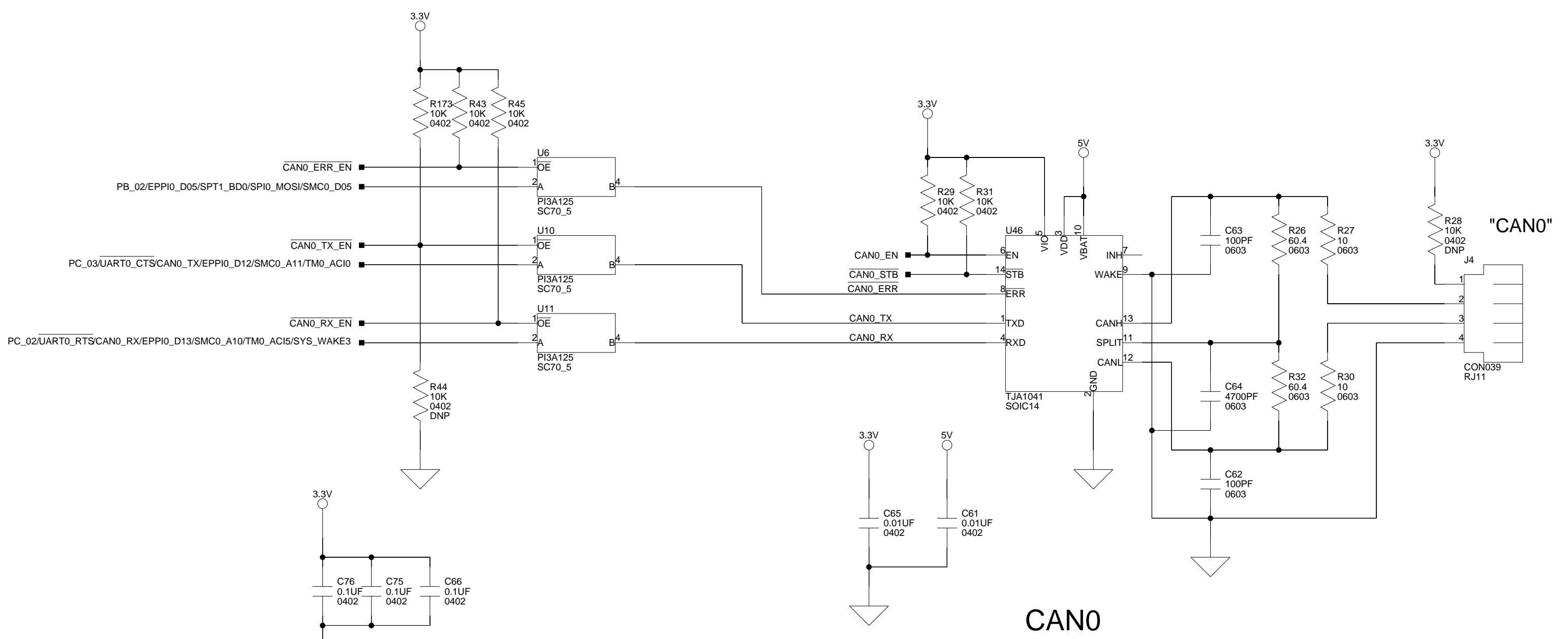

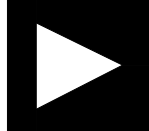
 ANALOG DEVICES		20 Cotton Road Nashua, NH 03063 PH: 1-800-ANALOGD	
		Title ADSP-BF707 EZ-BOARD CAN0, CAN1	
Size C	Board No. A0450-2013	Rev 1.0	
Date 04/04/2014	Sheet 7		of 13

"USB to UART"

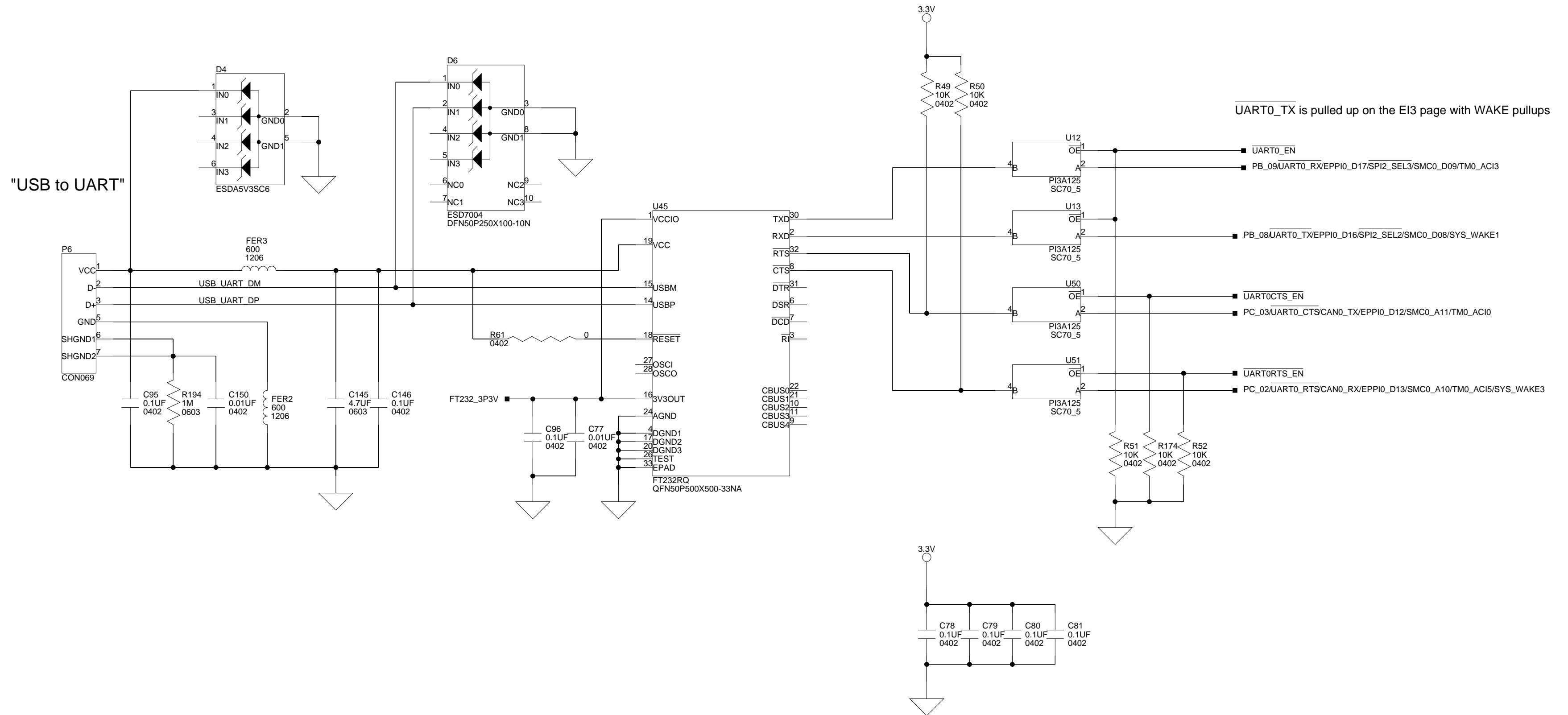

UART0_TX is pulled up on the EI3 page with WAKE pullups

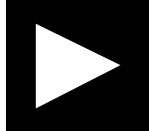
 ANALOG DEVICES		20 Cotton Road Nashua, NH 03063 PH: 1-800-ANALOGD	
		Title ADSP-BF707 EZ-BOARD UART0, USB to UART	
Size C	Board No. A0450-2013	Rev 1.0	
Date 04/04/2014	Sheet 8	of 13	

TWI address 0100 001x
 where x is the R/W bit. Read - 1, Write - 0

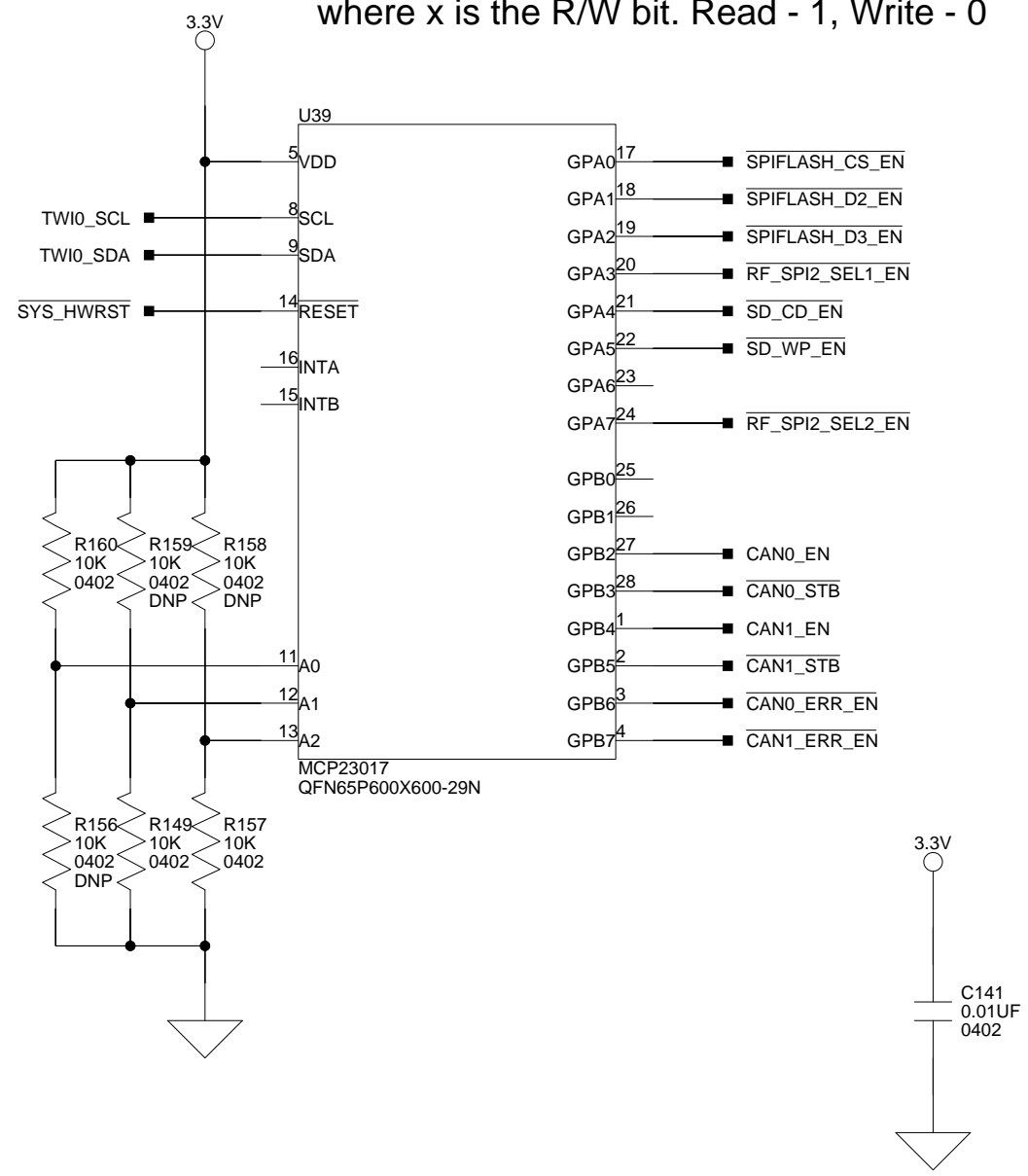

TWI address 0100 010x
 where x is the R/W bit. Read - 1, Write - 0

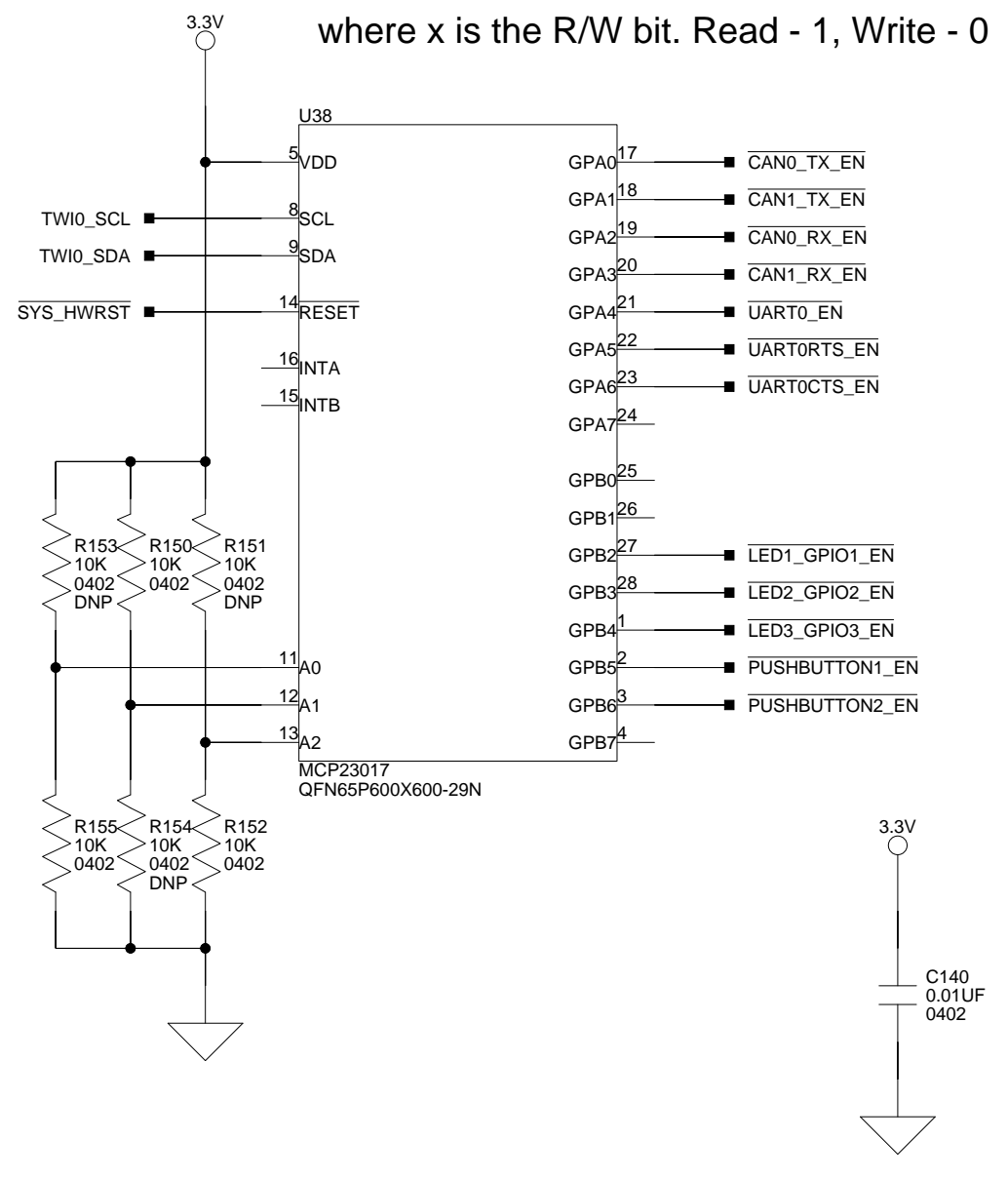

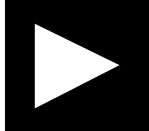
 ANALOG DEVICES		20 Cotton Road Nashua, NH 03063 PH: 1-800-ANALOGD	
		Title ADSP-BF707 EZ-BOARD SoftConfig	
Size C	Board No. A0450-2013	Rev 1.0	
Date 04/04/2014	Sheet 9		of 13

A

B

C

D

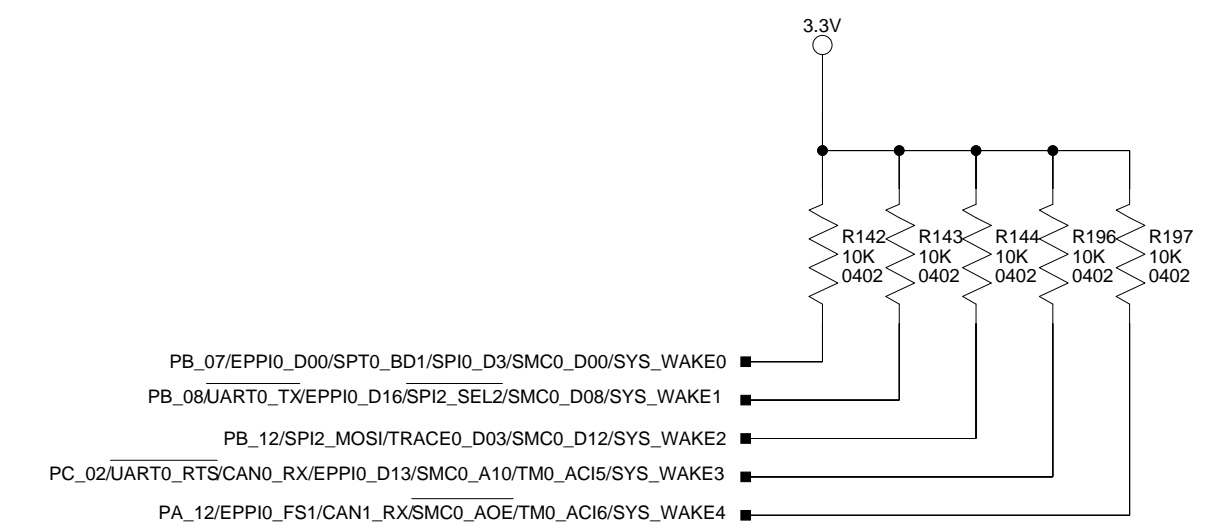
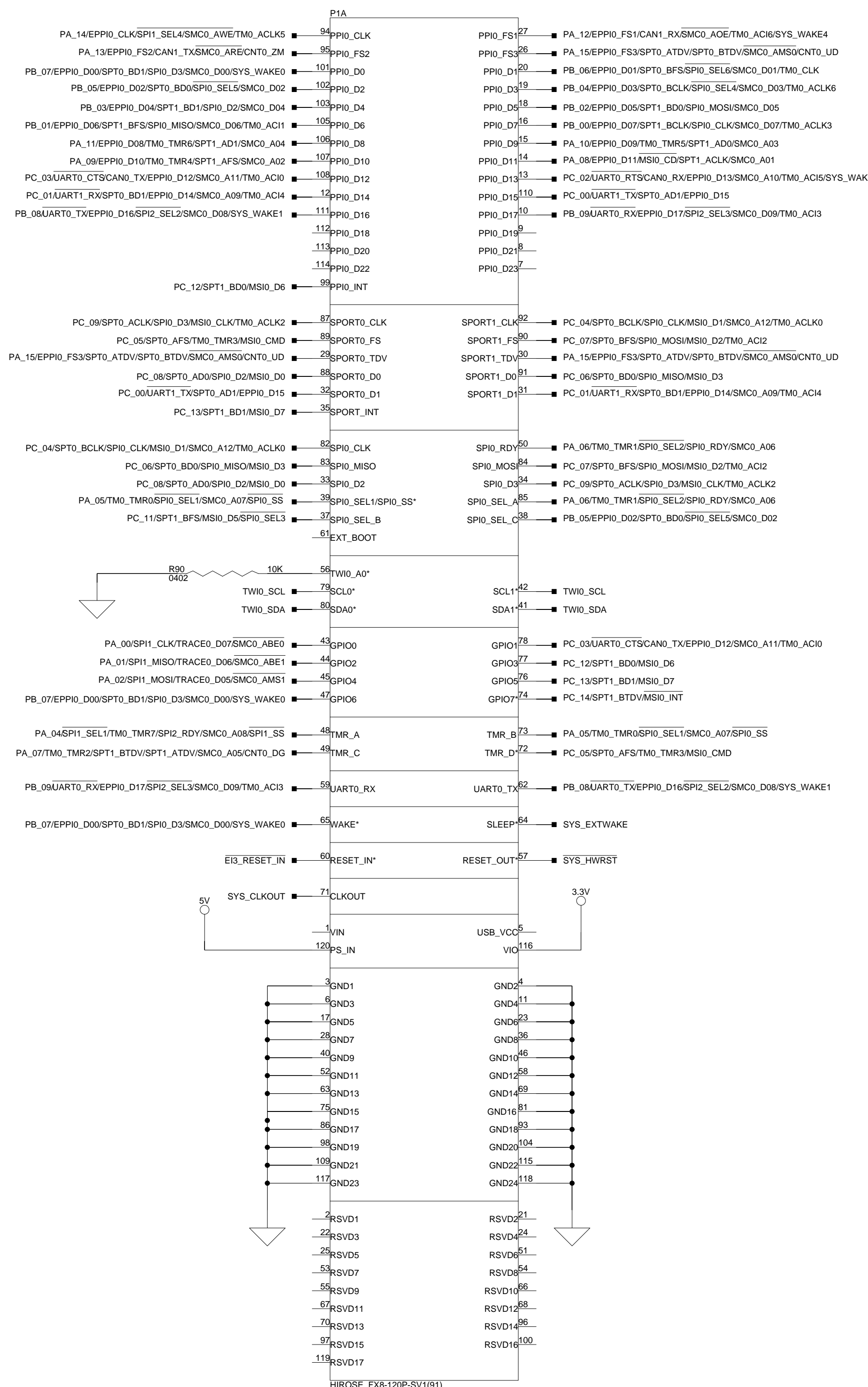

A

B

C

D

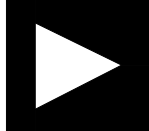
 ANALOG DEVICES		20 Cotton Road Nashua, NH 03063 PH: 1-800-ANALOGD	
		Title ADSP-BF707 EZ-BOARD E13 1A Conn	
Size C	Board No. A0450-2013	Rev 1.0	
Date 04/04/2014	Sheet 10		of 13

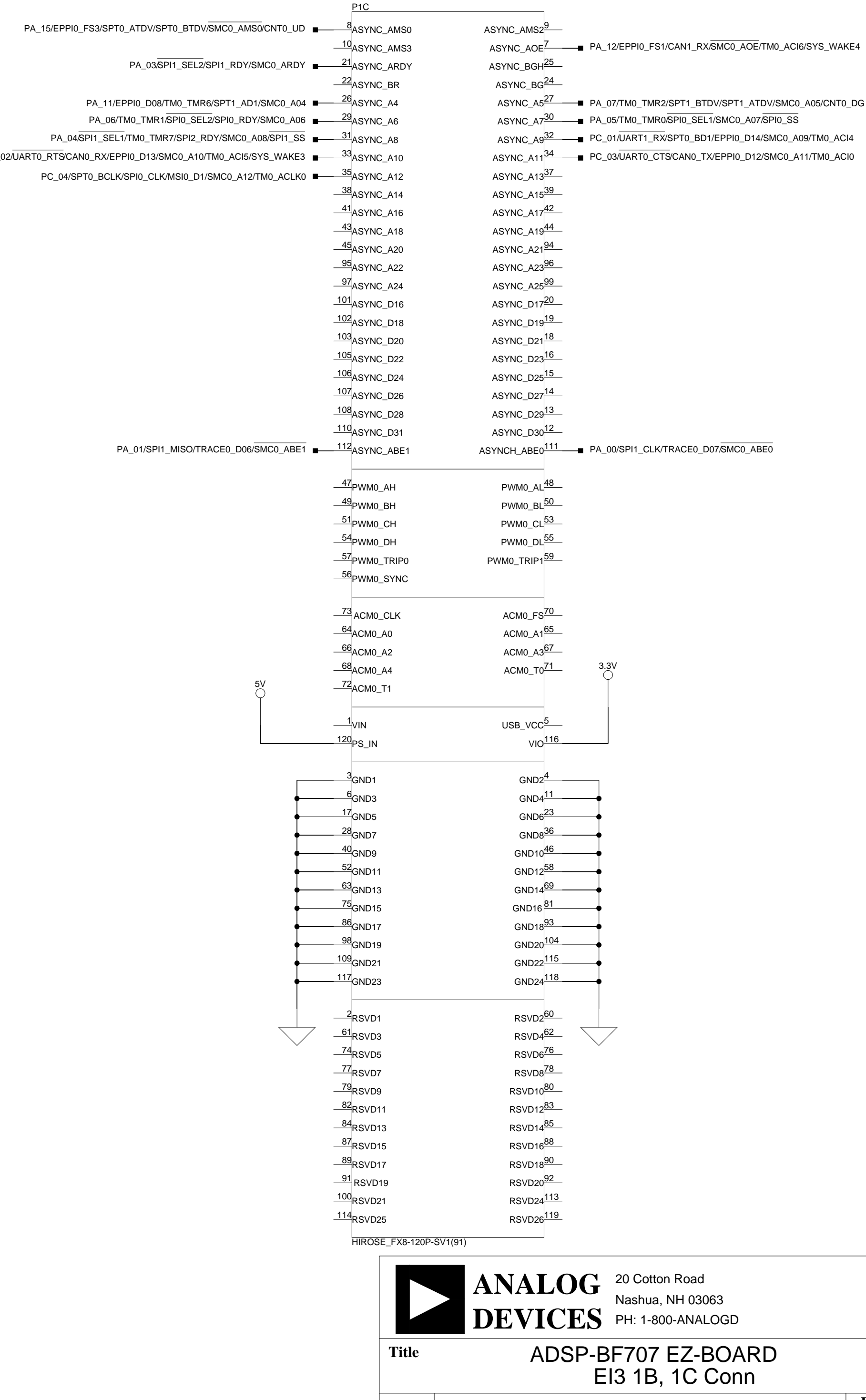
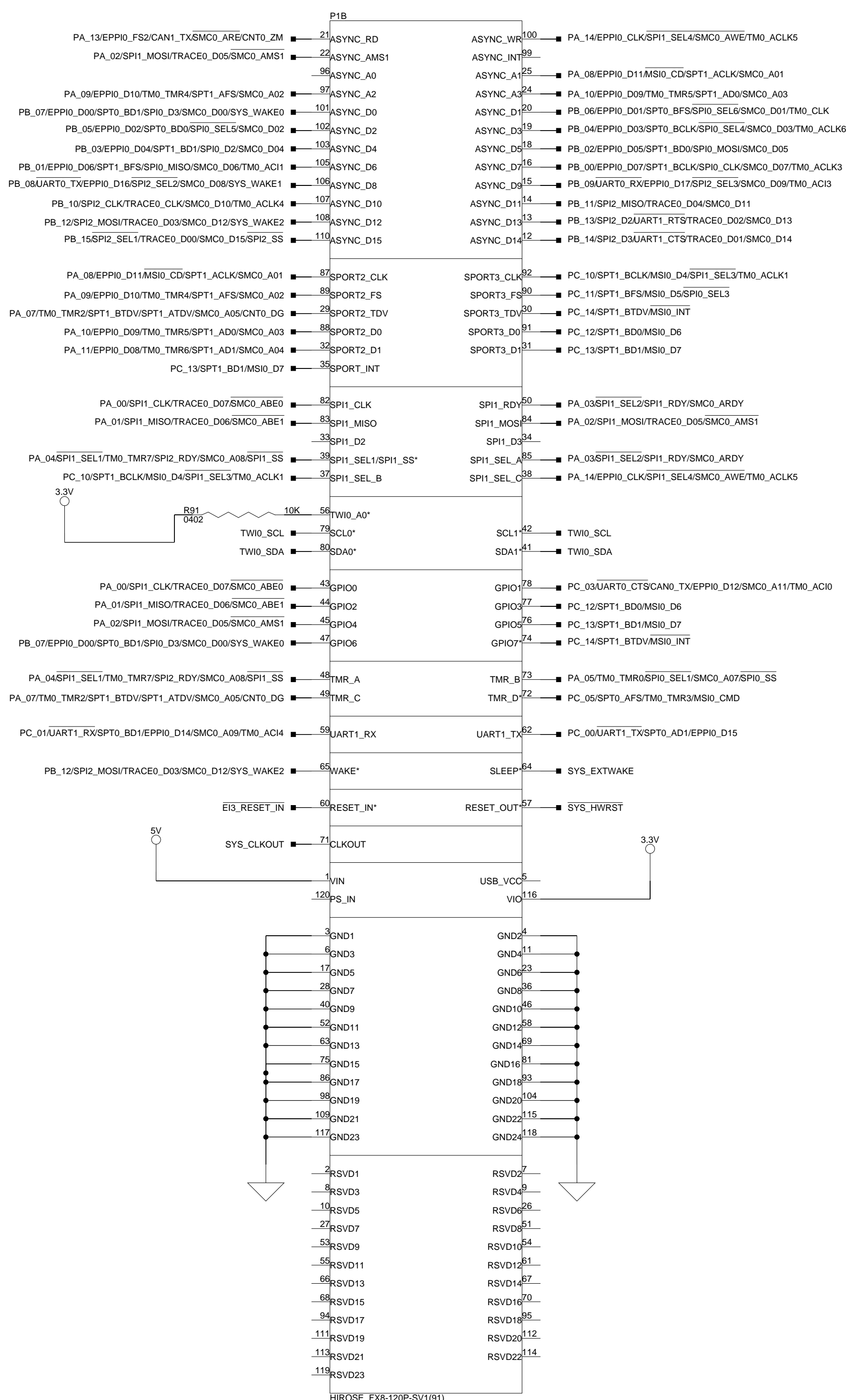

ANALOG DEVICES 20 Cotton Road
Nashua, NH 03063
PH: 1-800-ANALOGD

Title ADSP-BF707 EZ-BOARD EI3 1B, 1C Conn		
Size C	Board No. A0450-2013	Rev 1.0
Date 04/04/2014	Sheet 11 of 13	

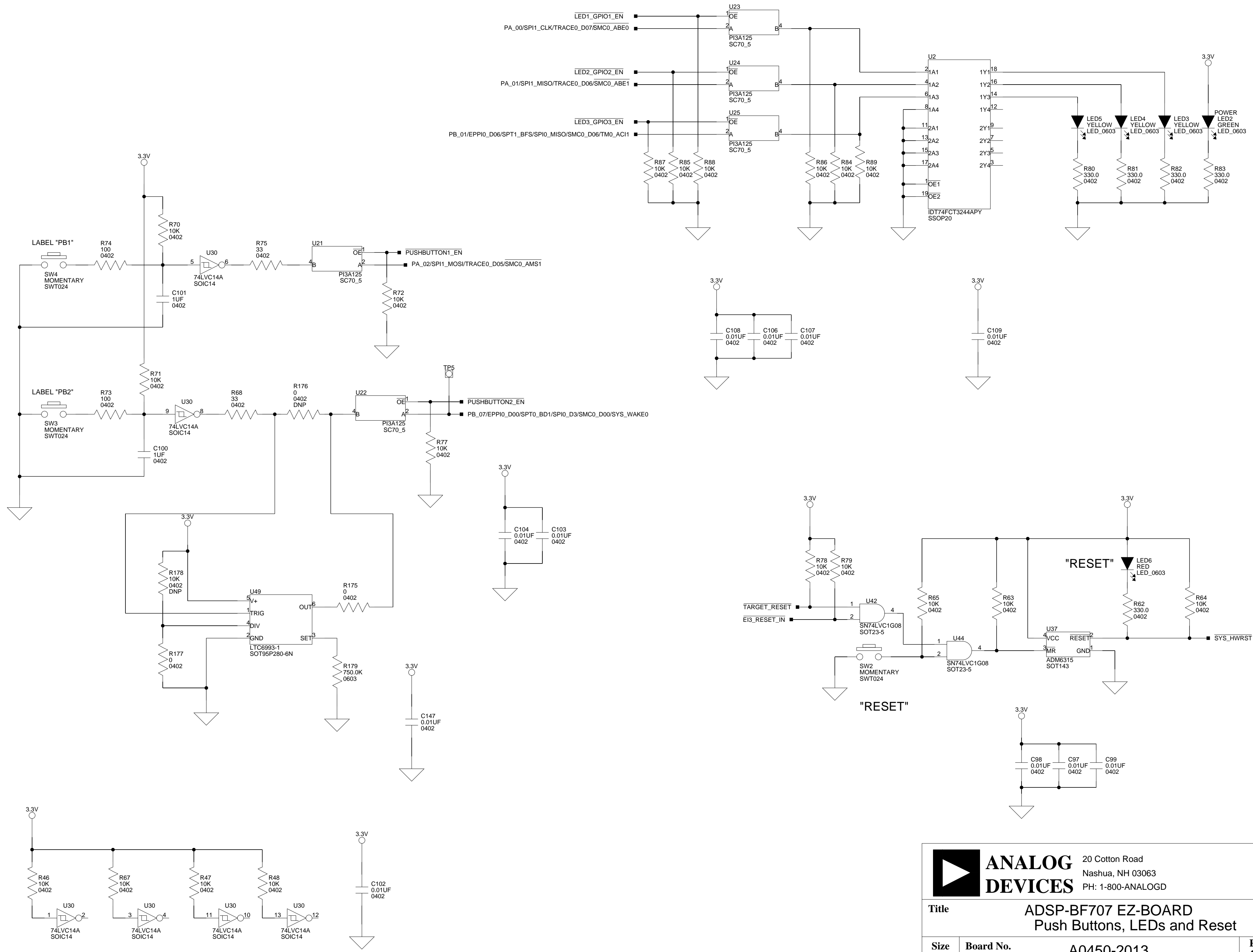

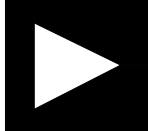
 ANALOG DEVICES		20 Cotton Road Nashua, NH 03063 PH: 1-800-ANALOGD	
		Title ADSP-BF707 EZ-BOARD Push Buttons, LEDs and Reset	
Size C	Board No. A0450-2013	Rev 1.0	
Date 04/04/2014	Sheet 12		of 13

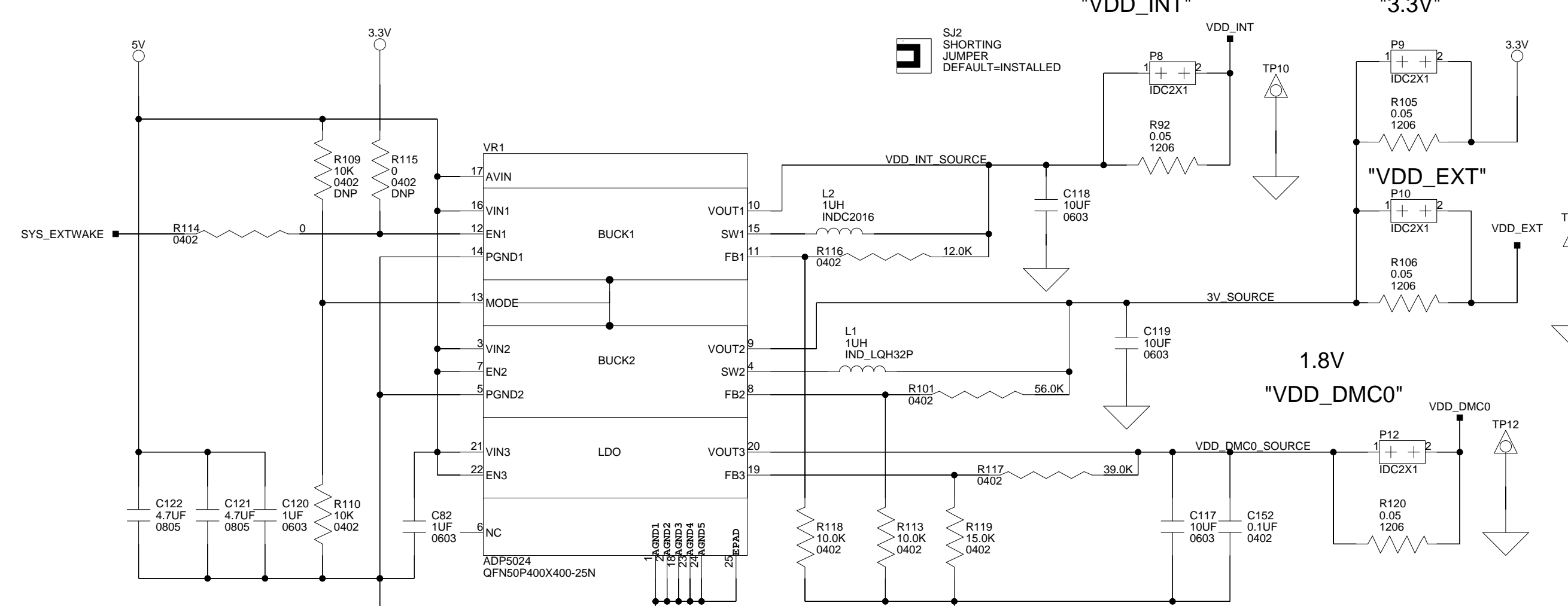
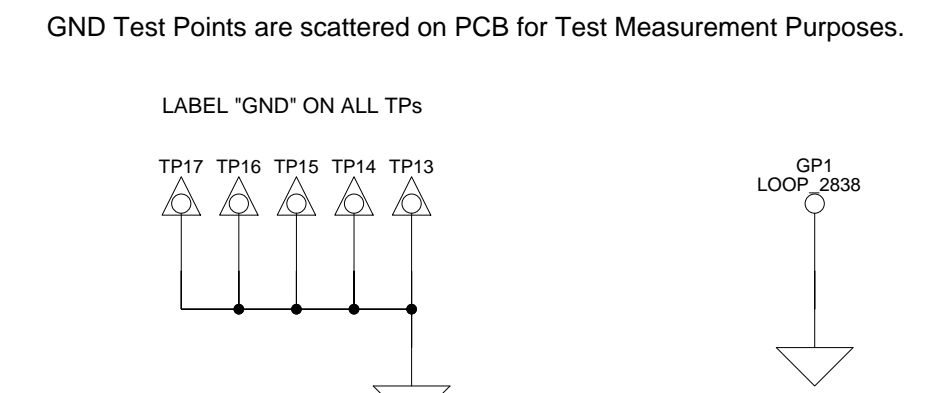
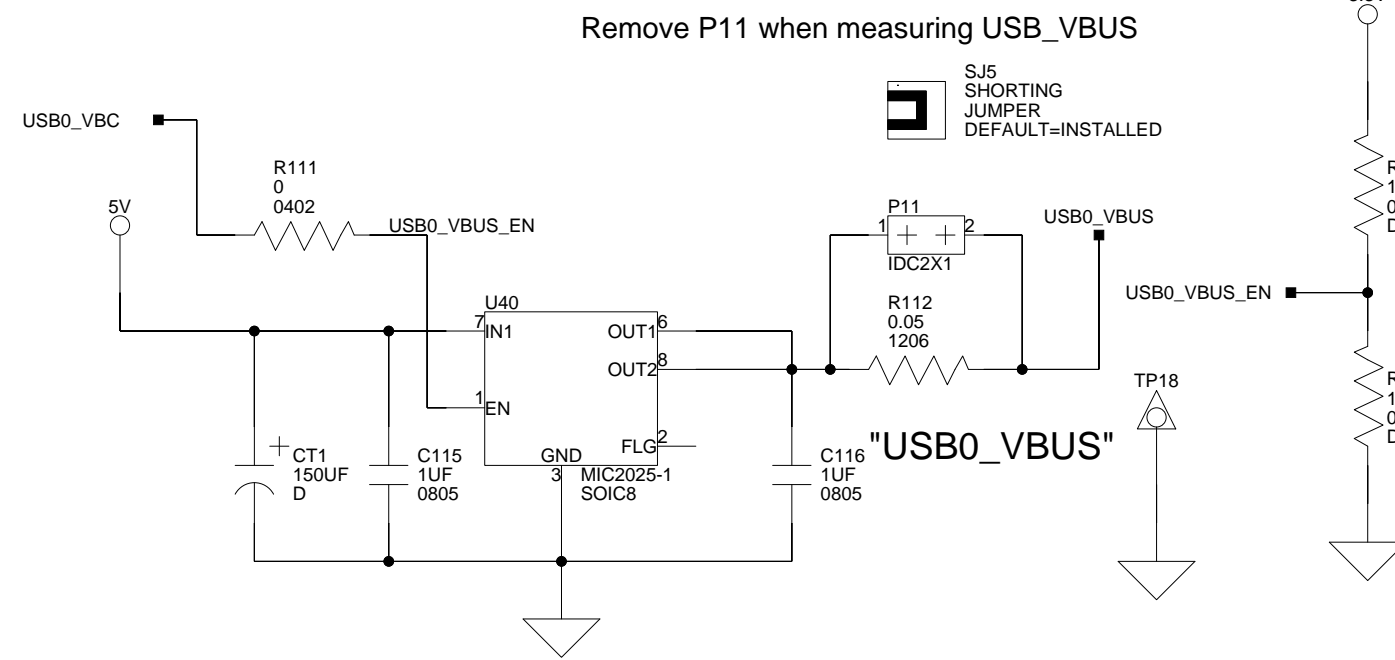
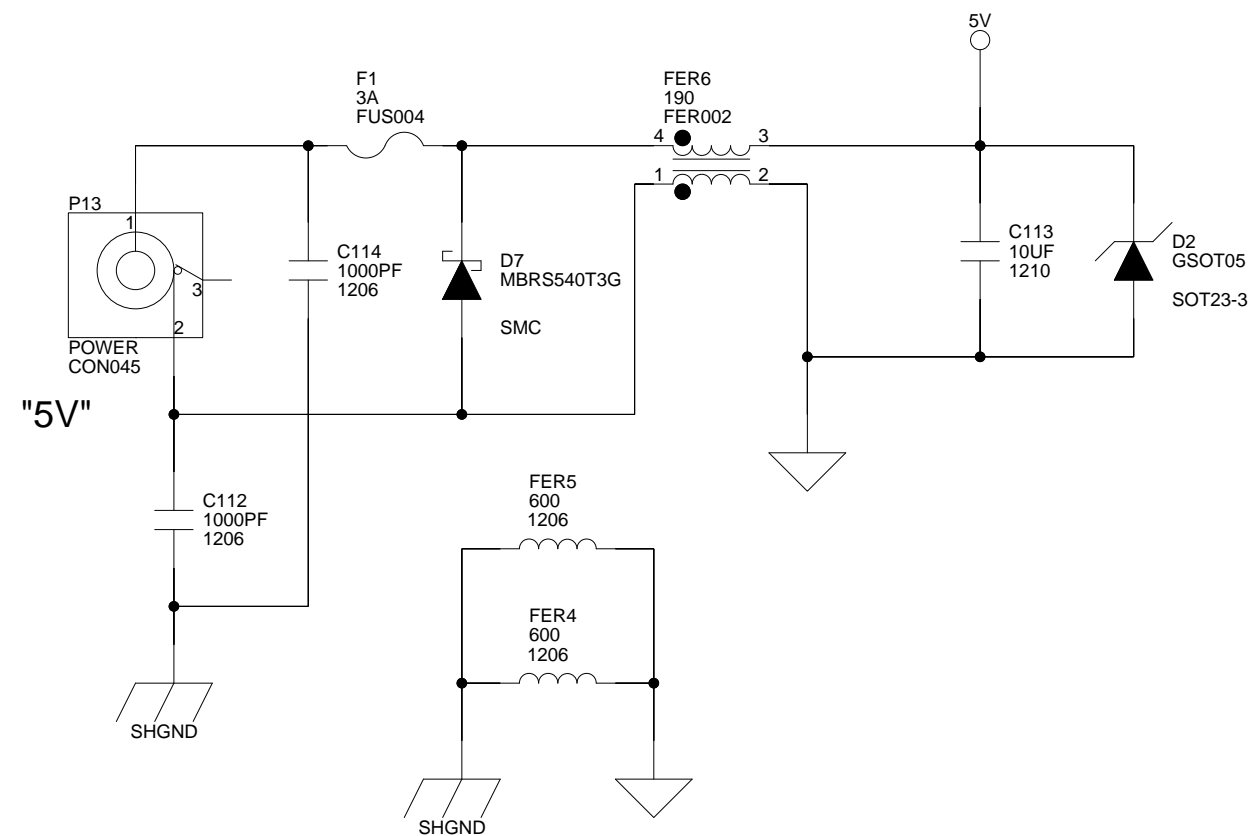

TWI address 1000 000x
 where x is the R/W bit. Read - 1, Write - 0

TWI address 1000 001x
 where x is the R/W bit. Read - 1, Write - 0

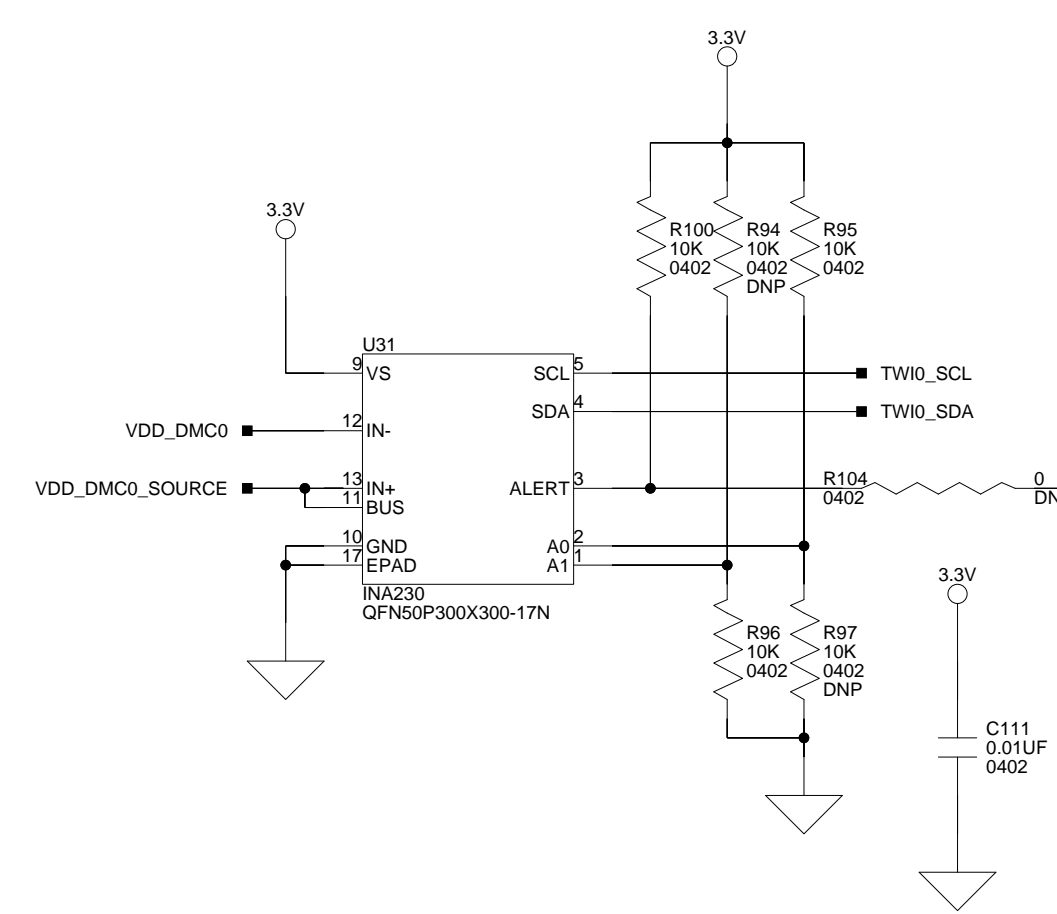
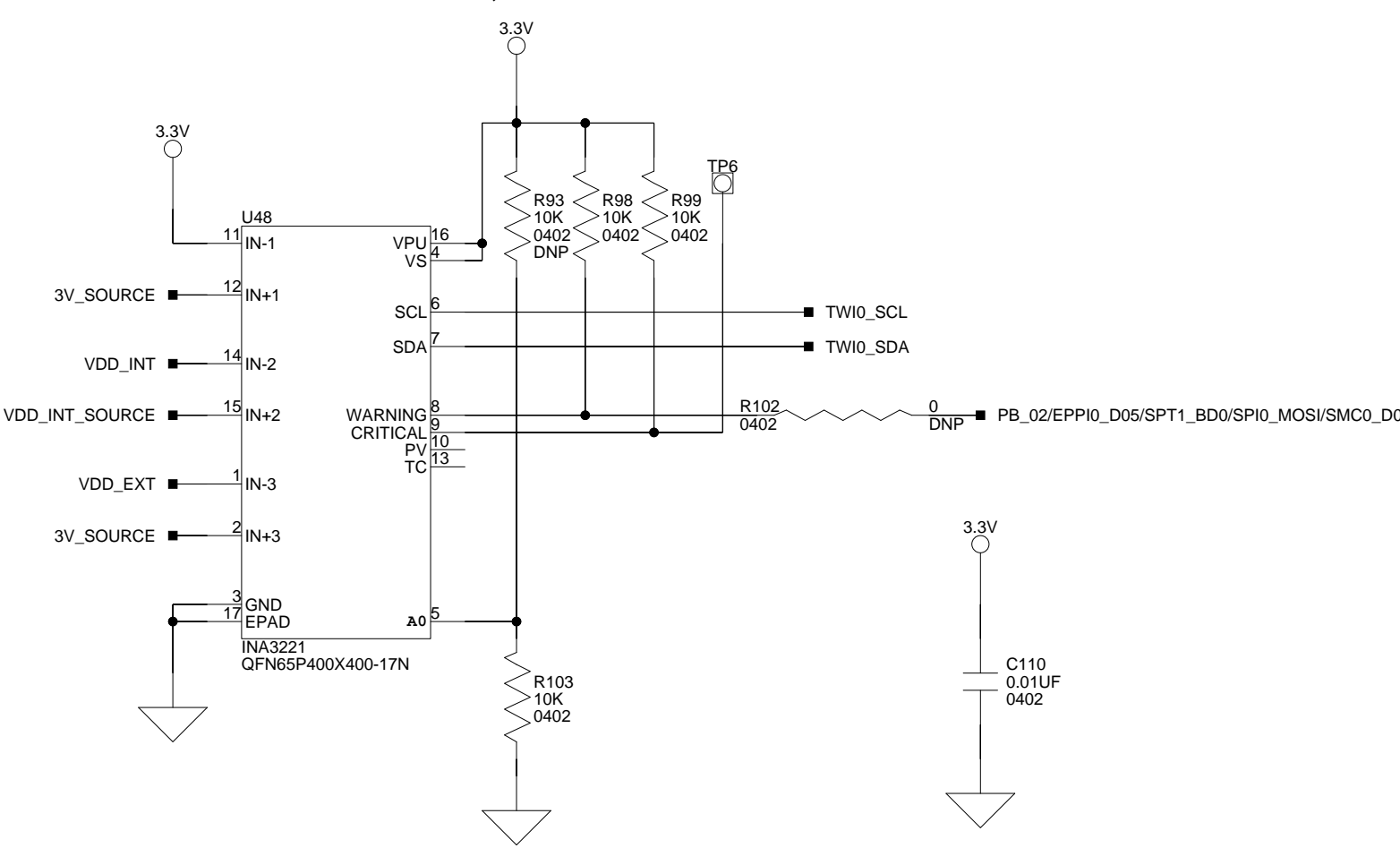

		20 Cotton Road Nashua, NH 03063 PH: 1-800-ANALOGD	
Title ADSP-BF707 EZ-BOARD Power			
Size C	Board No. A0450-2013	Rev 1.0	
Date 04/04/2014		Sheet 13 of 13	

I INDEX

A

ADSP-BF707 processor, [x](#)
architecture, of this EZ-KIT Lite, [2-2](#)

B

bill of materials, [A-1](#)
board schematic (ADSP-BF707), [B-1](#)
boot mode select switch (SW1), [2-17](#)
bus switch, [2-5](#)
 example, [2-6](#)

C

CAN0 connector (J4), [2-24](#)
CAN0 interface, [1-10](#)
CAN1 connector (J5), [2-25](#)
CAN1 interface, [1-11](#)
configuration, of this EZ-KIT Lite, [1-3](#)
connectors, [2-21](#)
 diagram of locations, [2-21](#)
 J3 (RF wireless), [2-23](#)
 J4 (CAN0), [2-24](#)
 J5 (CAN1), [2-25](#)
 J6 (SD), [2-24](#)
 J7, J8, J9 (HADC SMC), [2-23](#)
 JP1 (HADC), [2-24](#)
 P13 (power), [2-22](#)
 P1A-C (expansion interface III), [2-22](#)
 P2 (TRACE and JTAG/SWD/SWO), [2-25](#)
 P3 (JTAG/SWD/SWO), [2-25](#)

connectors *(continued)*

 P5 (USB), [2-23](#)
 P6 (USB to UART), [2-22](#)
contents, of this EZ-KIT Lite package, [1-2](#)

D

DDR2 memory, [1-8](#)
debug interface, [1-12](#)
default configuration, of this EZ-KIT Lite, [1-3](#)
default jumper and switch settings, [1-4](#)
default processor interface availability, [2-7](#)
design reference information, [1-15](#)

E

EngineerZone, [xvii](#)
evaluation license, [1-8](#)
example programs, [1-14](#)
expansion interface, [1-13](#)
expansion interface III connectors (P1A-C),
 [2-22](#)

F

FET switches, [2-4](#)
 example, [2-4](#)

G

general-purpose I/O pins (GPIO), [2-20](#)
GPIO LEDs (LED3-5), [2-20](#)
GPIO push buttons switches (SW3-4), [2-17](#)

Index

H

HADC, [1-10](#)
HADC connector (JP1), [2-24](#)
HADC SMC connectors (J7, J8, J9), [2-23](#)
housekeeping ADC, [1-10](#)

I

installation, of this EZ-KIT Lite, [1-4](#), [1-5](#)
interface
 CAN0, [1-10](#)
 CAN1, [1-11](#)
 debug, [1-12](#)
 SD, [1-12](#)
 UART0, [1-10](#)
 USB, [1-11](#)

J

JTAG/SWD/SWO connector (P3), [2-25](#)
jumpers
 diagram of locations, [2-18](#)

L

LEDs, [2-19](#)
 diagram of locations, [2-19](#)
 LED1 (SYS_FAULT), [2-20](#)
 LED2 (power), [2-20](#)
 LED3-5 (GPIO), [2-20](#)
 LED6 (reset), [2-20](#)
license restrictions, [1-8](#)

M

mechanical switch, [2-5](#), [2-7](#)

N

notation conventions, [xvii](#)

P

package contents, [1-2](#)
power
 architecture, [1-13](#)
 LED (LED2), [2-20](#)
 measurements, [1-14](#)
power connector (P13), [2-22](#)
power jumpers, listing, [2-18](#)
power jumpers (P8-12, P14-18), [2-18](#)
power-on-self test (POST), [1-12](#)
product overview, [x](#)
programming SoftConfig switches, [2-8](#)
push buttons and switches, [2-16](#)

R

reset LED (LED6), [2-20](#)
reset push button switch (SW2), [2-17](#)
RF wireless connector (J3), [2-23](#)

S

schematic, of ADSP-BF707 EZ-KIT Lite, [B-1](#)
SD connector (J6), [2-24](#)
SD interface, [1-12](#)
SoftConfig
 on the EZ-KIT Lite, [2-7](#), [2-10](#)
 overview, [2-3](#)
 programming switches, [2-8](#)
SPI flash, [1-9](#)
startup, of this EZ-KIT Lite, [1-6](#)
supported tools, [xvi](#)
switches
 programming SoftConfig, [2-8](#)
 SW1 (boot mode select), [2-17](#)
 SW2 (reset push button), [2-17](#)
 SW3-4 (GPIO push buttons), [2-17](#)
switches, diagram of locations, [2-16](#)
SYS_FAULT LED (LED1), [2-20](#)
system architecture, of this EZ-KIT Lite, [2-2](#)

T

technical support, [xv](#)

TRACE and JTAG/SWD/SWO connector
(P2), [2-25](#)

U

UART0 interface, [1-10](#)

USB connector (P5), [2-23](#)

USB interface, [1-11](#)

USB to UART connector (P6), [2-22](#)