

AEAT-901x Magnetic Encoder

10, 12, 14, 16, or 18-bit Angular Detection Device

Overview

The Broadcom[®] AEAT-901x series of magnetic encoders provides an integrated solution for angular detection. With ease of use in mind, these magnetic encoders are ideal for angular detection within 360°. Based on magnetic technologies, the device is noncontact and ensures reliable operations. It is able to provide absolute angle detection upon power-up, with a resolution of 0.0014 (18-bits version), 0.0055° (16-bits version), 0.022° (14-bits version), 0.0879° (12-bits version) or 0.35° (10-bits version), which is equivalent to 262144, 65536, 16384, 4096, and 1024 positions per revolution respectively. The positional data is provided in serial bit stream. There is no upper speed limit; the only restriction is that there will be fewer samples per revolution as the speed increases.

Exploded View

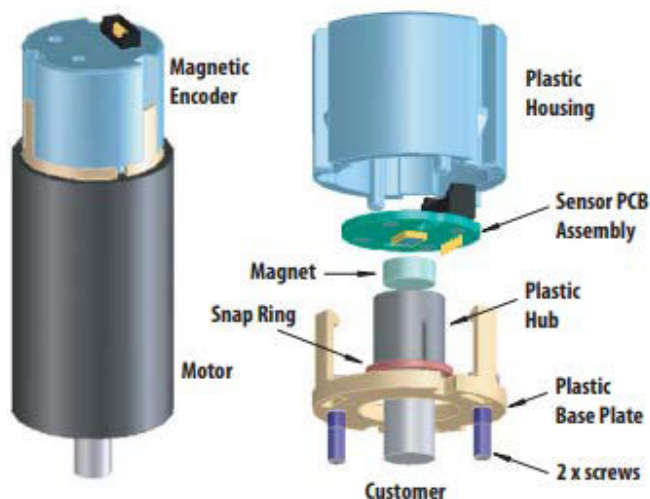

Features

- 10, 12, 14, 16, or 18 bits resolution
- Contactless sensing technologies
- Wide temperature range from –40°C to 125°C
- Absolute angular position detection
- Synchronous serial interface (SSI) output for absolute position data (binary format)
- Typical code monotony error = ± 1 LSB
- 5V supply
- Easy assembly, no signal adjustment required
- RoHS compliant

Applications

- Flow meter
- Angular detection
- Knob control
- Rotary encoder

NOTE: This product is not specifically designed or manufactured for use in any specific device. Customers are solely responsible for determining the suitability of this product for its intended application and solely liable for all loss, damage, expense, or liability in connection with such use.

Device Selection Guide¹

Part Number	Resolution (bit)	Operating Temperature (°C)	Output Communication	DC Supply Voltage (V)
AEAT-9018-S06	18	-40 to +125	Serial	+5.0
AEAT-9016-S06	16	-40 to +125	Serial	+5.0
AEAT-9014-S06	14	-40 to +125	Serial	+5.0
AEAT-9012-S06	12	-40 to +125	Serial	+5.0
AEAT-9010-S06	10	-40 to +125	Serial	+5.0

Absolute Maximum Ratings

Stresses greater than those listed under Absolute Maximum Ratings may cause permanent damage to the device. This is stress rating only and functional operation of the device at these or any other conditions above those indicated in the operational sections of this specification is not implied. Exposure to absolute maximum rating conditions for extended periods may affect reliability.

Parameter	Symbol	Limits	Unit	Notes
DC Supply Voltage at Pin $V_{DD} = 5V$	V_{DD}	-0.3 to +7	V	
Input Voltage	V_i	-0.3 to $V_{DD} + 0.3$	V	
Storage Temperature	T_{STG}	-40 to 125	°C	

Recommended Operating Conditions

Parameter	Symbol	Limits	Unit	Notes
DC Supply Voltage at Pin $V_{DD} = 5V$	V_{DD}	+4.5/+5.5	V	
Operating Temperature	T_{AMB}	-40 to +125	°C	
Maximum Read-out Frequency	f_{CLK}	≤10	MHz	>0 MHz

DC Characteristics

DC Characteristics over Recommended Operating Range, typical at 25°C.

Parameter	Symbol	Min.	Typ.	Max.	Unit	Notes
V_{DD} Supply Current	I_{DD}	—	23	26	mA	
Output High Voltage D0	V_{OH}	—	—	—	V	
Output Low Voltage D0	V_{OL}	—	—	$V_{SS} + 0.4$	V	
Output Current D0	I_O	—	—	4	mA	V_{DD} pin = 4.5V
Input High Voltage CLK, CSn	V_{IH}	$0.7 \times V_{DD}$	—	—	V	CSn is internal pull-up
Input Low Voltage CLK, CSn	V_{IL}	—	—	$0.3 \times V_{DD}$	V	

1. For other options of Magnetic Encoder, contact the division sales representative for any customization.

Package Dimensions

Figure 1: Package and Recommended Mounting Dimensions

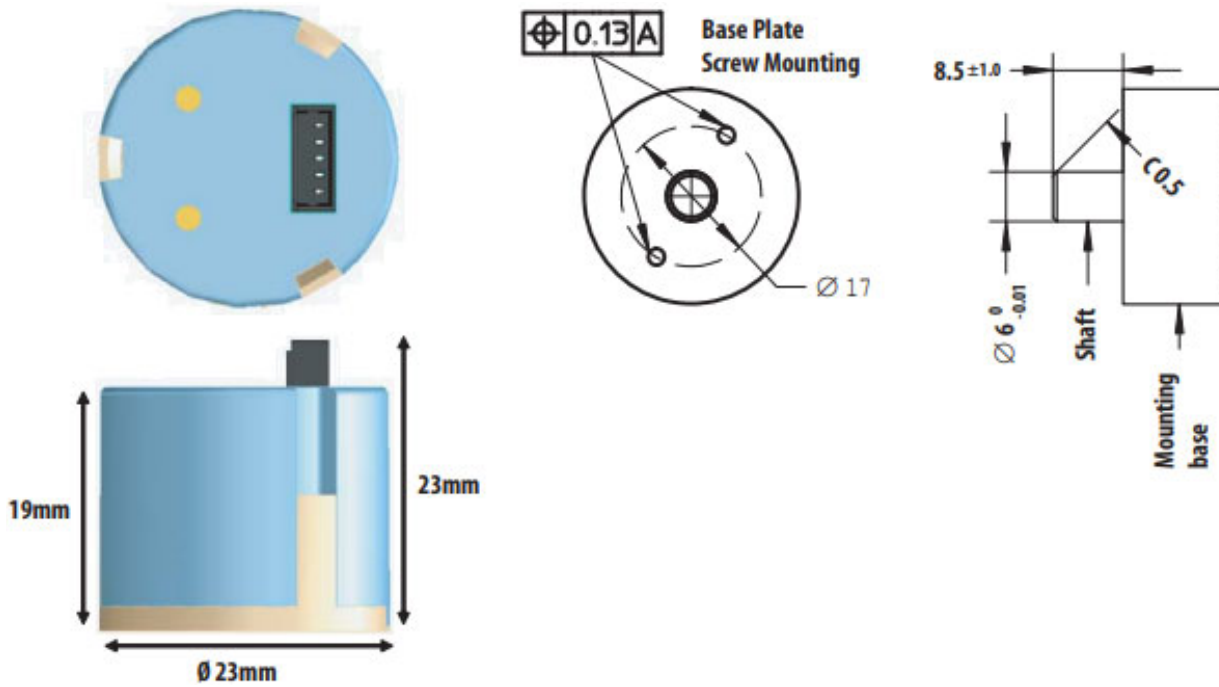

Table 1: Parameters

No	Parameter	Value
1	Operating Temp (°C)	-40 to +125
2	Shaft Axial Play (mm)	±0.08
3	Shaft TIR (mm)	0.05
4	Mechanical Speed (rpm)	12,000
5	Shaft Diameter (mm)	6 + 0/-0.01
6	Moment Inertia (g-cm ²)	0.104
7	Shaft Length (mm)	8.5 ± 1.0
8	Mounting Screw Size (mm)	M2 × 0.4 × 8 (socket head cap screw, head Ø3.8 ± 0.18 mm)
9	Recommended Screw Torque	0.6 lb.inch
10	Encoder Base Plate Thickness (mm)	2
11	Bolt Circle	±0.13

Timing

Table 2: Timing Characteristics

Parameter	Symbol	Min.	Typ.	Max.	Unit	Notes
Data Output Activated (Logic High)	$t_{DO\ active}$	—	—	100	ns	a,b
First Data Shifted to Output Register	$t_{CLK\ FE}$	300 (500)	—	—	ns	c,b
Start of Data Output	$T_{CLK/2}$	50 (500)	—	—	ns	d
Data Output Valid	$t_{DO\ valid}$	—	—	375	ns	e
Data Output Tristate	$t_{DO\ tristate}$	—	—	100	ns	f
Pulse Width of CSn	t_{CS}	200 (500)	—	—	ns	g,b
Sampling Rate for Absolute Output	f_{ABS}	9.90	10.42	10.94	kHz	h
Power-up Time	t_{CF}	—	—	10	ms	i

- a. Time between falling edge of CSn and data output activated.
- b. Values () reference to AEAT-601x series data sheet for comparison.
- c. Time between falling edge of CSn and first falling edge of CLK.
- d. Rising edge of CLK shifts out one bit a time.
- e. Time between rising edge of CLK and data output valid.
- f. After the last bit DO changes back to *tristate*.
- g. CSn = high; To initiate read-out of next angular position.
- h. Internal sampling rate.
- i. Until internal compensation finished.

Figure 2: Timing Diagram for 3-Wire SSI Magnetic Encoder

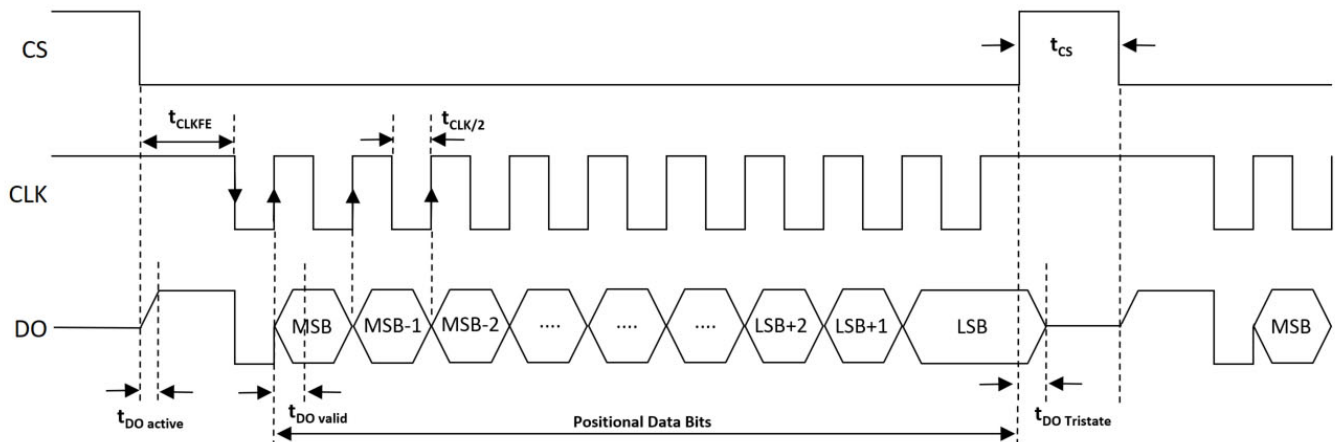

NOTE: Refer to [Table 2](#) for timing characteristics.

Linearity

Table 3: Linearity Characteristics

Parameter	Symbol	Min.	Typ.	Max.	Unit	Notes
Integral Nonlinearity	INL	—	±0.3 ^a	±0.8 ^b	Degrees	Typical ±0.3 for 12 bits to 18 bits version. Typical ±0.4 for 10 bits version.
Differential Nonlinearity	DNL					
10-bit Version		—	—	±0.176	Degrees	No missing codes.
12-bit Version		—	—	±0.044	Degrees	No missing codes.
14-bit Version		—	—	±0.02 ^c	Degrees	No missing codes.
16-bit Version		—	—	±0.02 ^c	Degrees	No missing codes.
18-bit Version	—	—	±0.02 ^c	Degrees	No missing codes.	

- a. Average value at typical operating and mounting conditions.
- b. Maximum value over recommended operating range and over radial and axial mounting tolerances.
- c. DNL typical values at nominal operating condition, room temperature 25°C.

Linearity Definitions

Integral Nonlinearity

Integral nonlinearity (INL) is the maximum deviation between actual angular position and the position indicated by the encoder's output count, over one revolution. It is defined as the most positive linearity error +INL or the most negative linearity error -INL from the best fit line, whichever is larger.

Differential Nonlinearity

Differential nonlinearity (DNL) is the maximum deviation of the step length from one position to the next.

Figure 3: Integral Nonlinearity

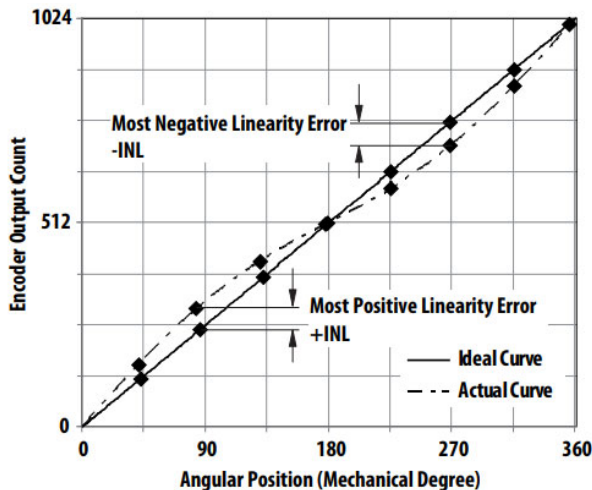

Environmental Specifications

Parameter	Reference Standard	Test Conditions	Level
Electromagnetic Compatibility (EMC) ^a			
Electrostatic Discharge (ESD) Immunity	IEC/EN 61000-4-2	8 kV	
Mechanical Durability			
Vibration (Operating)	IEC/EN 60068-2-6	10 Hz to 500 Hz at 5G	
Shock	IEC/EN 60068-2-27	6 ms at 200G	

a. Suitable for applications in Industrial Environment Class 4.

Electrical Connections

Figure 4: Electrical Connections

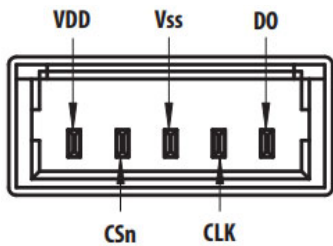
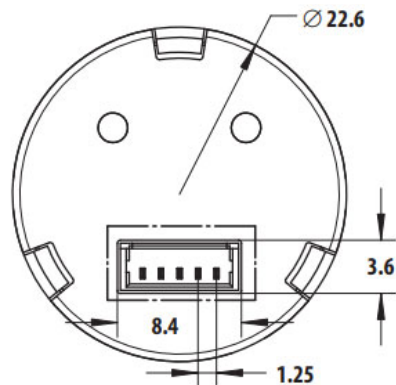

Table 4: Pin Descriptions

Pin	Symbol	Description
1	VDD	5V Supply Voltage
2	CSn	Chip Select, Input (See Figure 4.)
3	VSS	Supply Ground
4	CLK	Serial Clock, Input (See Figure 4.)
5	DO	Serial Data, Output (See Figure 4.)

Figure 5: Basic Connector Dimensions



Alignment Tool Set – Part Number HEDS-8934

This optional alignment tool set consists of a gap setting plate and a centering jig. Refer to Application Note 5317 for the assembly guide.

Figure 6: Alignment Tool Set and Recommended Dimensions

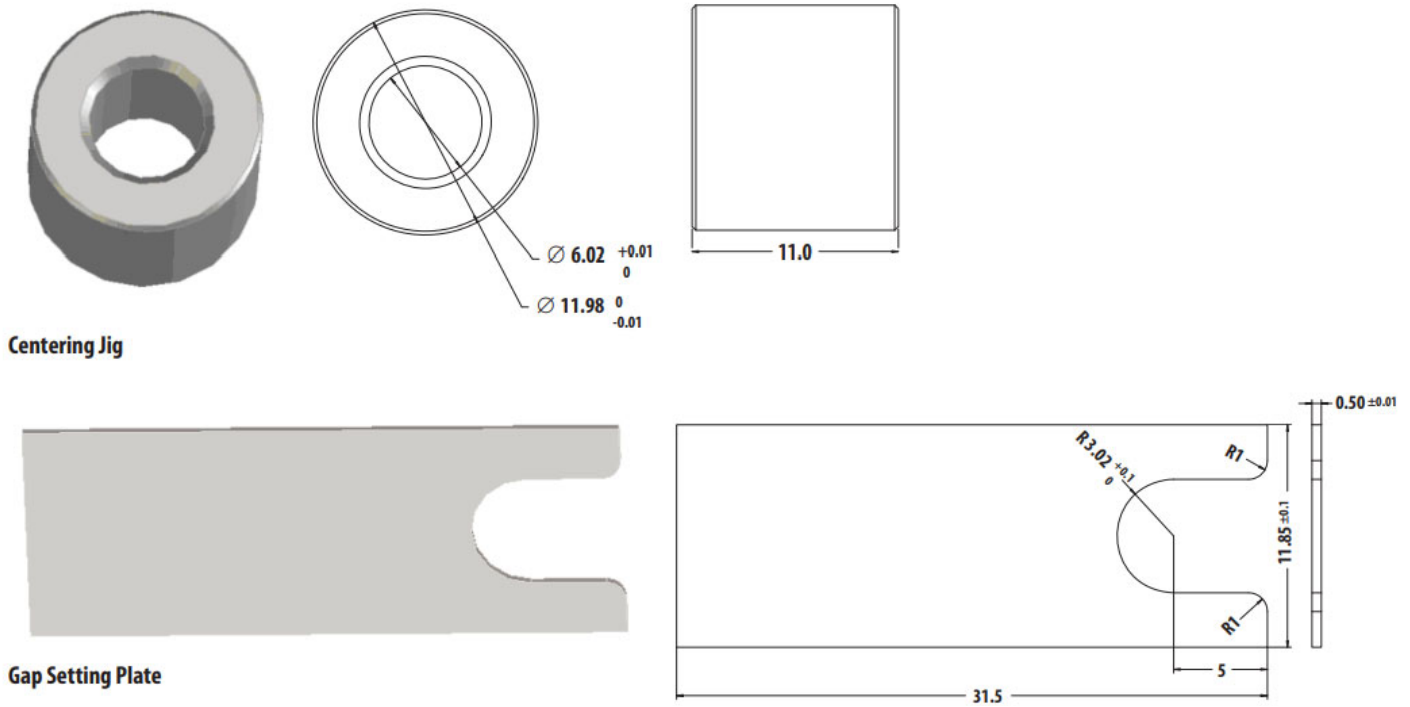

Ordering Information

