

# AEDB-9140 Series

## Three Channel Optical Incremental Encoder Modules with Codewheel, 100 CPR to 500 CPR



## Data Sheet



### Description

The AEDB-9140 series are three channel optical incremental encoder modules offered with a codewheel. When used with a codewheel, these low cost modules detect rotary position. Each module consists of a lensed LED source and a detector IC enclosed in a small plastic package. Due to a highly collimated light source and a unique photodetector array, these modules are extremely tolerant to mounting misalignment.

The AEDB-9140 has two channel quadrature outputs plus a third channel index output. This index output is a 90 electrical degree high true index pulse which is generated once for each full rotation of the codewheel.

The AEDB-9140 is designed for use with a codewheel which has an optical radius of 11.00 mm (0.433 inch).

The quadrature signals and the index pulse are accessed through five 0.46 mm square pins located on 1.27 mm (pitch) centers.

### Features

- Two Channel Quadrature Output with Index Pulse
- Resolution from 100 CPR to 500 CPR (Counts Per Revolution)
- Low Cost
- Easy to Mount
- No Signal Adjustment required
- Small Size
- Operating Temperature: -10°C to 85°C
- TTL Compatible
- Single 5V Supply

### Applications

The AEDB-9140 provide sophisticated motion control detection at a low cost, making them ideal for high volume applications. Typical applications include printers, plotters, tape drives, and industrial and factory automation equipment.

Note: Avago Technologies encoders are not recommended for use in safety critical applications. Eg. ABS braking systems, power steering, life support systems and critical care medical equipment. Please contact sales representative if more clarification is needed.

## Ordering Information

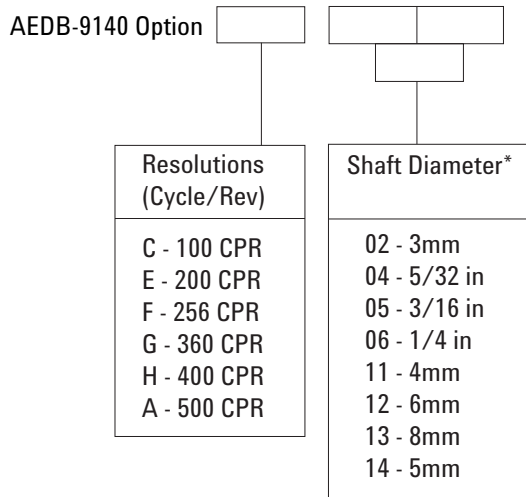

### Three Channel Encoder Modules with Codewheel, 11 mm Optical Radius

\* Please contact factory for other shaft diameters

### Available Options

Part No	CPR	Shaft Diameter Options							
		02	04	05	06	11	12	13	14
AEDB-9140	C		•		•		•	•	
	E				•	•	•		•
	F		•				•		•
	G				•		•		•
	H				•				•
	A	•	•	•	•	•	•	•	•

## Theory of Operation

The AEDB-9140 are emitter/detector modules. Coupled with a codewheel, these modules translate the rotary motion of a shaft into a three-channel digital output.

As seen in Figure 1, the modules contain a single Light Emitting Diode (LED) as its light source. The light is collimated into a parallel beam by means of a single polycarbonate lens located directly over the LED. Opposite the emitter is the integrated detector circuit. This IC consists of multiple sets of photodetectors and the signal processing circuitry necessary to produce the digital waveforms.

The codewheel rotates between the emitter and detector, causing the light beam to be interrupted by the pattern of spaces and bars on the codewheel.

The photodiodes which detect these interruptions are arranged in a pattern that corresponds to the radius and design of the code-wheel. These detectors are also spaced such that a light period on one pair of detectors corresponds to a dark period on the adjacent pair of detectors.

The photodiode outputs are then fed through the signal processing circuitry resulting in A, Abar, B, Bbar, I and Ibar. Comparators receive these signals and produce the final outputs for channels A and B. Due to this integrated phasing technique, the digital output of channel A is in quadrature with that of channel B (90 degrees out of phase).

### Block Diagram

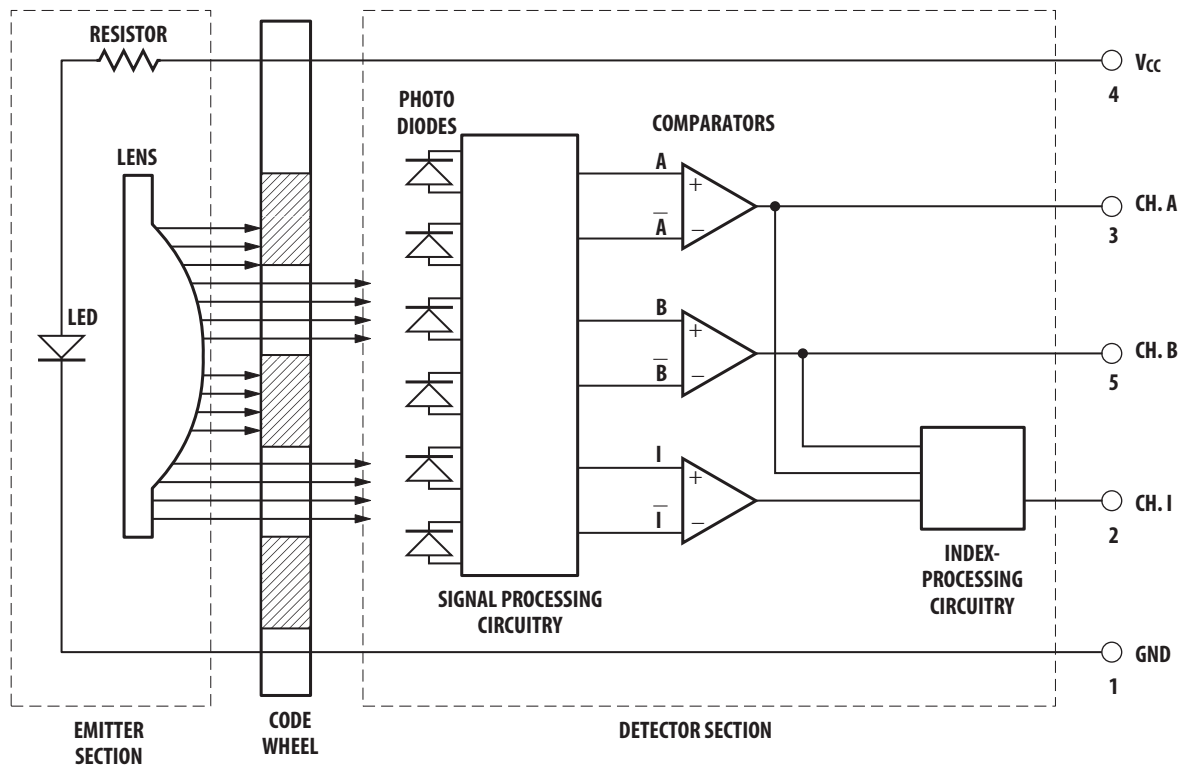

Figure 1.

### Output Waveforms

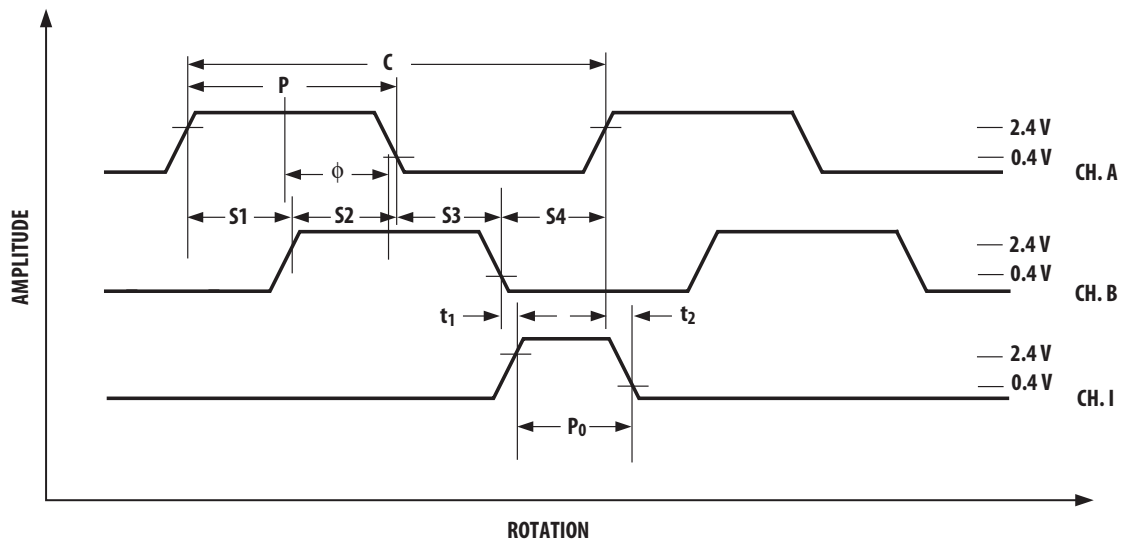

Figure 2.

## Definitions

Note: Refer to Figure 2

Count (N): The number of bar and window pairs or counts per revolution (CPR) of the codewheel.

One Cycle (C): 360 electrical degrees ( $^{\circ}e$ ), 1 bar and window pair.

One Shaft Rotation: 360 mechanical degrees, N cycles.

Position Error ( $\Delta\Theta$ ): The normalized angular difference between the actual shaft position and the position indicated by the encoder cycle count.

Cycle Error ( $\Delta C$ ): An indication of cycle uniformity. The difference between an observed shaft angle which gives rise to one electrical cycle, and the nominal angular increment of  $1/N$  of a revolution.

Pulse Width (P): The number of electrical degrees that an output is high during 1 cycle. This value is nominally  $180^{\circ}e$  or  $1/2$  cycle.

Pulse Width Error ( $\Delta P$ ): The deviation, in electrical degrees, of the pulse width from its ideal value of  $180^{\circ}e$ .

State Width (S): The number of electrical degrees between a transition in the output of channel A and the neighboring transition in the output of channel B. There are 4 states per cycle, each nominally  $90^{\circ}e$ .

State Width Error ( $\Delta S$ ): The deviation, in electrical degrees, of each state width from its ideal value of  $90^{\circ}e$ .

Phase (f): The number of electrical degrees between the center of the high state of channel A and the center of the high state of channel B.

This value is nominally  $90^{\circ}e$  for quadrature output.

Phase Error ( $\Delta\phi$ ): The deviation of the phase from its ideal value of  $90^{\circ}e$ .

Direction of Rotation: When the codewheel rotates in the clockwise direction viewing from top of the module (direction from V to G), channel A will lead channel B. If the codewheel rotates in the opposite direction, channel B will lead channel A.

Optical Radius (Rop): The distance from the codewheel's center of rotation to the optical center (O.C) of the encoder module.

Index Pulse Width (Po): The number of electrical degrees that an index is high during one full shaft rotation. This value is nominally  $90^{\circ}e$  or  $1/4$  cycle.

## Absolute Maximum Ratings

Parameter	Symbol	Minimum	Typical	Maximum	Units	Notes
Storage Temperature	T <sub>S</sub>	-10		85	°C	
Operating Temperature	T <sub>A</sub>	-10		85	°C	
Supply Voltage	V <sub>CC</sub>	-0.5		7	Volts	
Output Voltage	V <sub>O</sub>	-0.5		V <sub>CC</sub>	Volts	
Output Current per Channel, I <sub>out</sub>	I <sub>OUT</sub>	-1.0		18	mA	

## Recommended Operating Conditions

Parameter	Symbol	Min.	Typ.	Max.	Units	Notes
Temperature	T <sub>A</sub>	-10		85	°C	
Supply Voltage	V <sub>CC</sub>	4.5	5.0	5.5	Volts	Ripple < 100mVp-p
Load Capacitance	C <sub>L</sub>			100	pF	2.7 kΩ pull-up
Frequency	f			100	kHz	Velocity (rpm) x N/60
Shaft Perpendicularity Plus Axial Play				± 0.20(± 0.008)	mm(in.)	Refer to Mounting Consideration
Shaft Eccentricity Plus Radial Play				± 0.04(± 0.0015)	mm(in.)	

## Electrical Characteristics

Electrical Characteristics Over the Recommended Operating Range. Typical Values at 25°C.

Parameter	Symbol	Minimum	Typical	Maximum	Units	Notes
Supply Current	I <sub>CC</sub>	30	57	85	mA	
High Level Output Voltage	V <sub>OH</sub>	2.4			V	Typ. I <sub>OH</sub> = -0.5 mA
Low Level Output Voltage	V <sub>OL</sub>			0.4	V	Typ. I <sub>OL</sub> = 10 mA
Rise Time	t <sub>r</sub>		180		ns	C <sub>L</sub> = 25 pF R <sub>L</sub> = 2.7 kΩ pull-up
Fall Time	t <sub>f</sub>		50		ns	

Note: Typical values specified at V<sub>CC</sub> = 5.0 V and 25 °C

## Encoding Characteristics

Encoding Characteristics Over the Recommended Operating Conditions and Recommended Mounting Tolerances unless otherwise specified.

Parameter	Symbol	Minimum	Typical	Maximum	Units	Notes
Cycle Error	$\Delta C$		3	10	$^{\circ}e$	
Pulse Width Error	$\Delta P$		7	30	$^{\circ}e$	
Logic State Width Error	$\Delta S$		5	30	$^{\circ}e$	
Phase Error	$\Delta \phi$		2	15	$^{\circ}e$	
Position Error	$\Delta \Theta$		10	40	min. of arc	
Index Pulse Width	$P_0$	60	90	120	$^{\circ}e$	
CH I rise after CH B or CH A fall	$t_1$	-10°C to + 85°C	10	100	1000	ns
CH I fall after CH A or CH B rise	$t_2$	-10°C to + 85°C	10	300	1000	ns

## Electrical Interface

To insure reliable encoding performance, the AEDB-9140 three channel encoder modules require 2.7 k $\Omega$  ( $\pm 10\%$ ) pull-up resistors on output pins 2, 3, and 5 (Channels A, I and B) as shown in Figure 3. These pull-up resistors should be located as close to the encoder module as possible (within 4 feet). Each of the three encoder module outputs can drive a single TTL load in this configuration.

## Customized Solutions

Customization of codewheel CPR is possible. It has to be based on the encoder LPI table given below:

Part Number	LPI
AEDB-9140 # C	36.7
AEDB-9140 # E	73.5
AEDB-9140 # F	94
AEDB-9140 # G	132.3
AEDB-9140 # H	147
AEDB-9140 # A	183

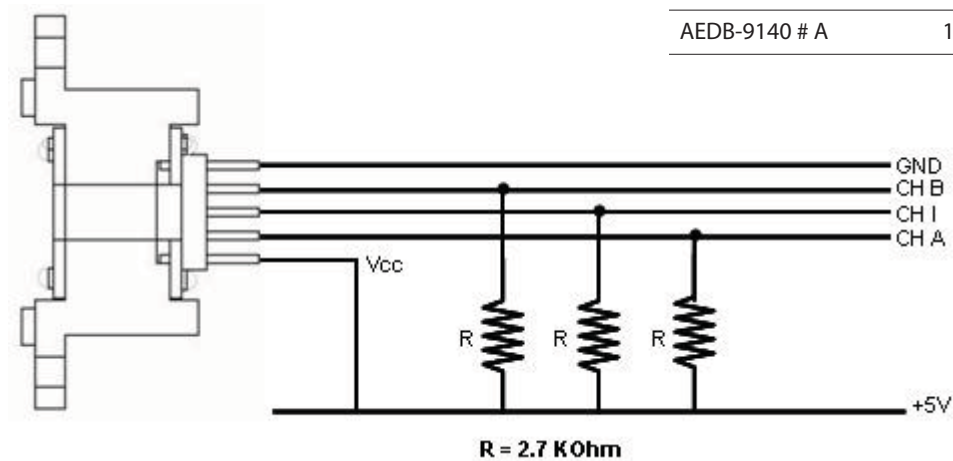

Figure 3.

**CPR calculation formula:**

$$CPR = (LPI \times 25.4) \times 2 \times \pi \times ROP$$

Where:

CPR = Counts Per Revolutions

LPI = Encoder LPI provided in the table

ROP = Encoder Optical Radius in mm

\* Recommended maximum Codewheel diameter should not exceed 30mm

Note: The customization of codewheel method is valid from theoretical standpoint. However Avago Technologies strongly recommends a full characterization to be done to determine the actual performance of the encoder with customized codewheel.

Characterization means validating the encoding performance (consist of cycle error, pulse width error, logic state width error, phase error, position error & index pulse width, index channel rise and fall time) over the recommended operating conditions and recommended mounting tolerances.

**Mounting Considerations**

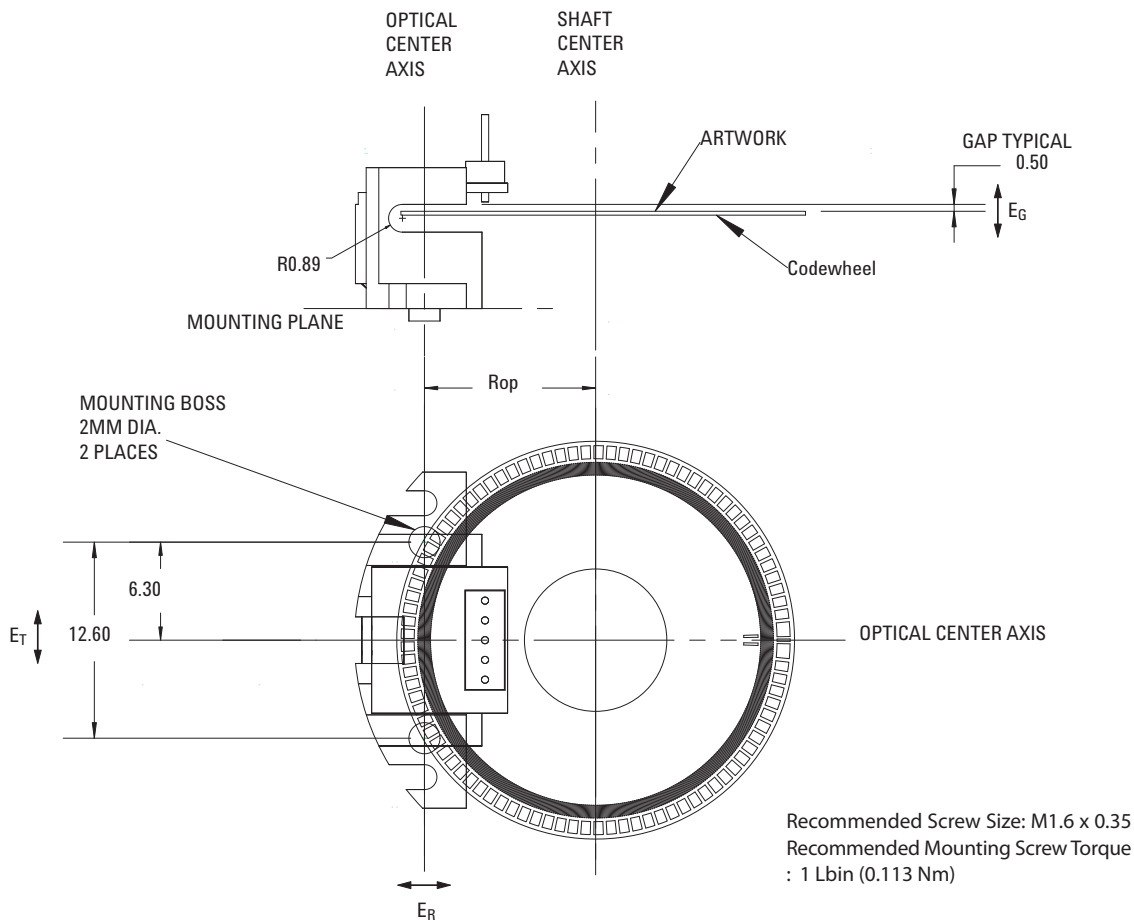

Note:

These dimensions include shaft endplay and codewheel warp. All dimension for mounting the module and codewheel should be measured with respect to two mounting boss, as shown above.

Error		ROP = 11mm	Unit	Notes
EG	Gap	± 0.20	mm	Recommend to mount the codewheel closer to the detector side (upper side) for optimum encoder performance.
ER	Radial	± 0.13	mm	
ET	Tangential	± 0.13	mm	

## Package Dimension

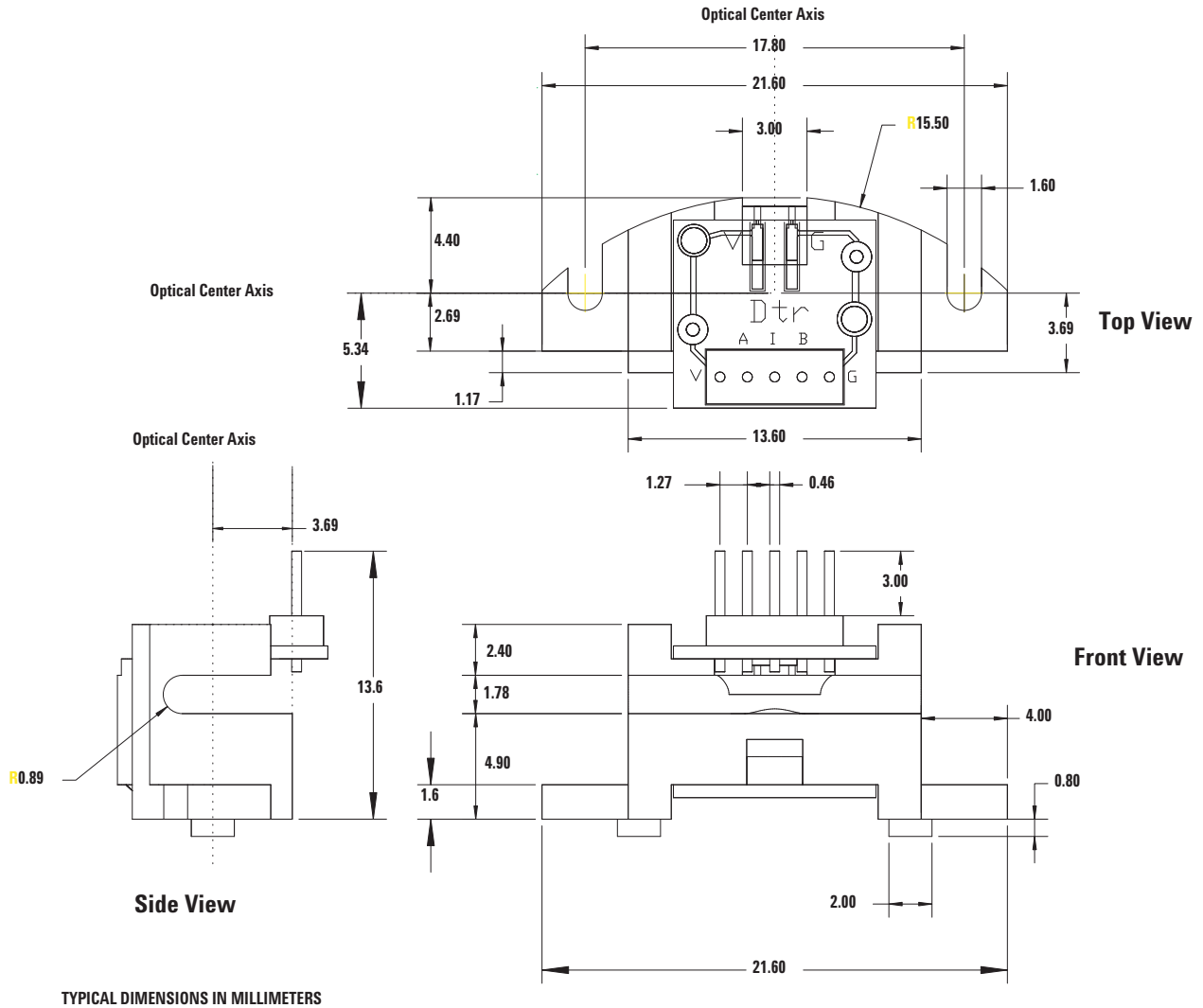

TYPICAL DIMENSIONS IN MILLIMETERS

## Codewheel Mechanical Drawing

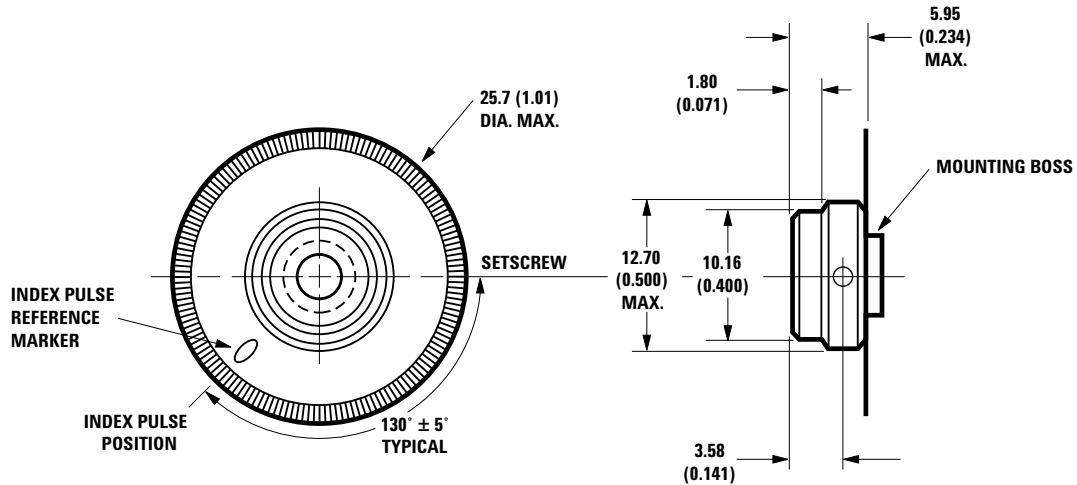

$$R_{op} = 11.00 \text{ mm (0.433 in.)}$$

DIMENSIONS IN MM (INCHES)