

## AEDL-5xxx

### Quick Assembly High Resolution Three Channel Optical Encoders with Differential Output



## Data Sheet



### Description

The AEDL-5xxx series encoders are high performance, low cost, three channel optical incremental encoders which offer line driver outputs. These encoders emphasize on high reliability, high resolution, and easy assembly.

Each encoder contains a LED source with lens, an ASIC with integrated photo detector arrays, LED current regulation, interpolator and output driver circuitry, and a code wheel which rotates between the emitter and detector ASIC. The outputs of the AEDL-5xxx is two square waves in quadrature. In addition, a third channel offers index signal, which is a 90 electrical degree, true index pulse which is generated once for each full rotation of the code wheel. The AEDL-5xxx series utilizes a film code wheel allowing for resolutions to 5000 CPR.

The line driver offers enhanced performance when the encoder is used in electronically noisy environments, or when it is required to drive long distances. AEDL-5xxx series utilize an industry standard line driver IC, AM26C31Q, which provides complementary outputs for each encoder channel. Thus, the output of the line driver encoder is A, A/, B, B/, I, I/. Suggested line receivers are 26LS32 and 26LS33.

Standard resolutions from 1000 to 5000 counts per revolution are presently available. Please consult local Avago sales representatives for other resolutions.

For additional information, please refer to:

- AV02-4924EN\_DS\_AEDT-981x
- AV02-4923EN\_AN-5595\_AEDT-981x
- AM26C31Q Datasheet (Texas Instruments)

### Features

- High resolution – up to 5000 CPR
- Operating temperature -40°C to +85°C
- User friendly installation process
- Complementary Outputs with industry standard Line Driver IC
- Single 5 V Supply with  $\pm 10\%$  tolerance
- Onboard decoupling capacitor for enhance noise immunity

---

Note: Avago Technologies encoders are not recommended for use in safety critical applications such as. ABS braking systems, power steering, life support systems and critical care medical equipment. Please contact our sales representative if clarifications are needed.

---

**CAUTION:** It is advised that normal static precautions be taken in handling and assembly of this component to prevent damage and/or degradation which may be induced by ESD.

# Package dimensions

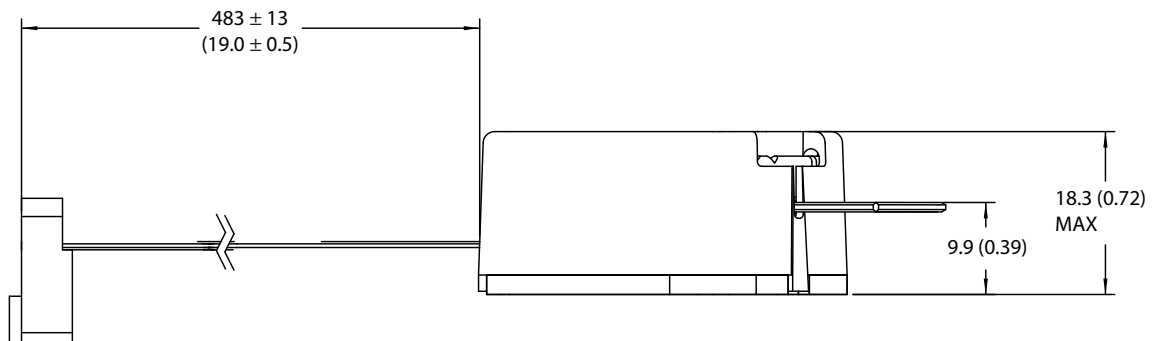
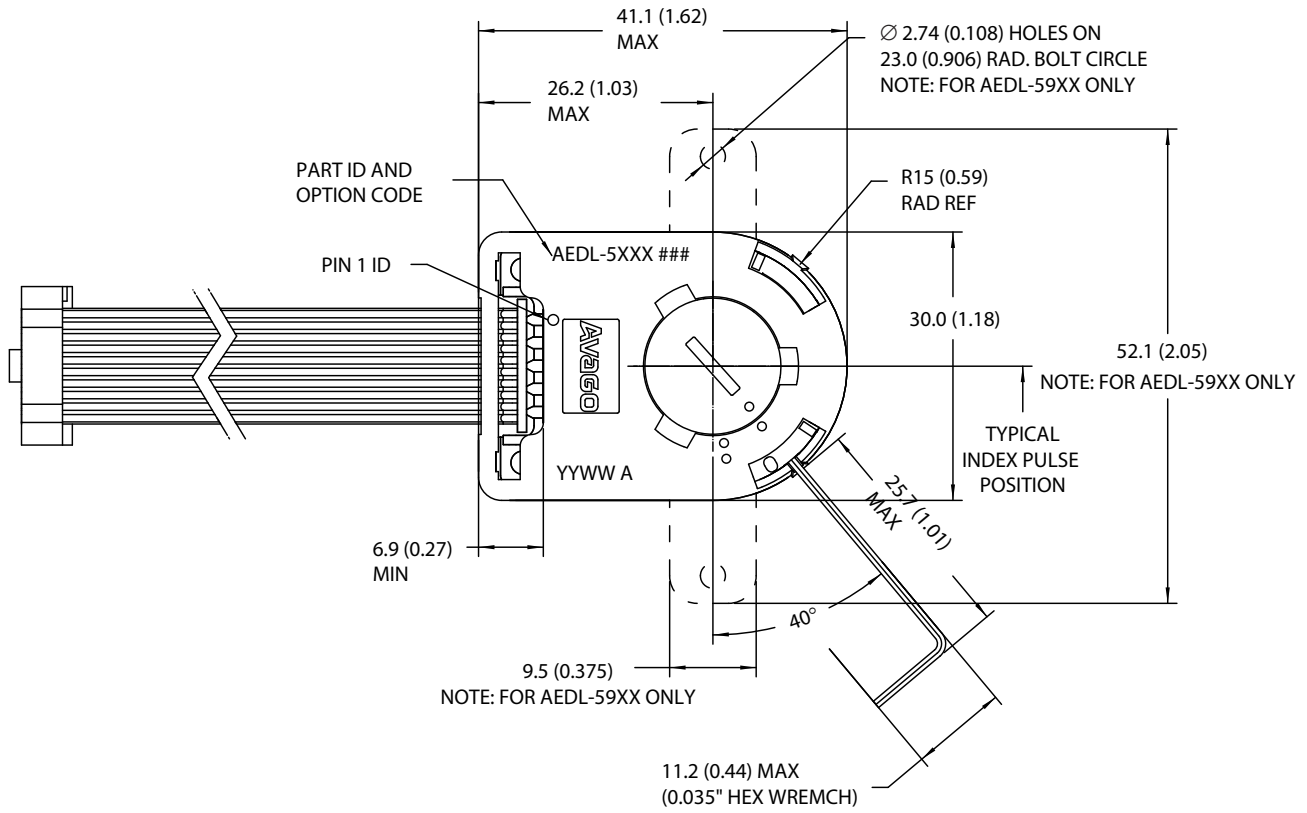

NOTE: DIMENSIONS IN MILLIMETERS (INCHES)

## Block Diagram

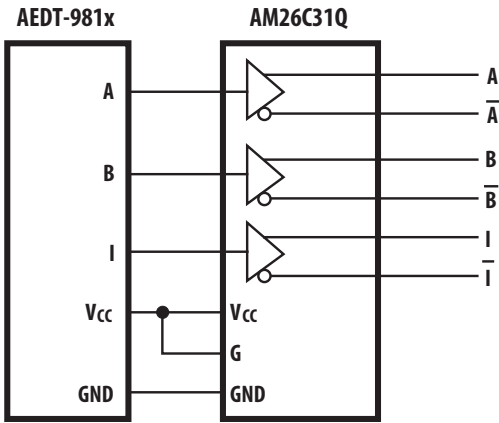

## Waveforms

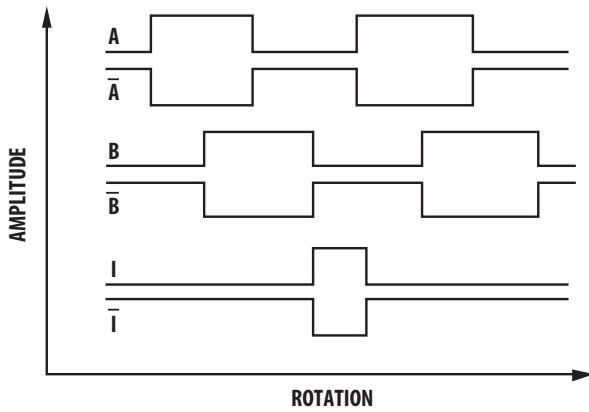

CCW view from top of encoder

## Pinout

10 POSITION IDC CONNECTOR, CENTER POLARIZED.

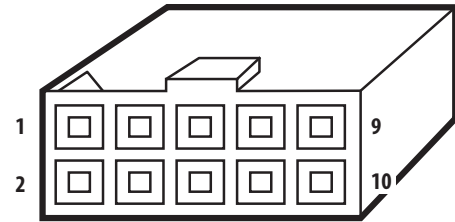

10-PIN CONNECTOR

NO.	COLOR	PARAMETER
1	BROWN	NC
2	RED	V <sub>CC</sub> (+ 5 V)
3	ORANGE	GND
4	YELLOW	NC
5	GREEN	A̅
6	BLUE	A
7	VIOLET	B̅
8	GREY	B
9	WHITE	I̅ (INDEX)
10	BLACK	I (INDEX)

## Absolute Maximum Ratings

Parameter	Symbol	Minimum	Maximum	Units
Storage Temperature	T <sub>S</sub>	-40	+85	°C
Operating Temperature	T <sub>A</sub>	-40	+85	°C
Supply Voltage	V <sub>CC</sub>	-0.5	7	V
Output Voltage	V <sub>O</sub>	-0.5	V <sub>CC</sub>	V
Output Current per Channel	I <sub>OUT</sub>		±20	mA
Velocity			12,000**	RPM

Note \*\*: Velocity 12000 RPM applies to Encoder Resolution of 5000 CPR

## Recommended Operating Conditions

Parameter	Symbol	Min.	Typ.	Max.	Units	Notes
Temperature	T <sub>A</sub>	-40		+85	°C	
Supply Voltage	V <sub>CC</sub>	4.5	5.0	5.5	Volt	Ripple < 100 mVp-p
Output Frequency	f			250	kHz	1000 – 1250 CPR
				500	kHz	2000 – 2500 CPR
				1,000	kHz	4000 – 5000 CPR
Shaft Perpendicularity Plus Axial Displacement				± 0.15 (± 0.006)	mm (in.)	
Spatial play (including shaft eccentricity)				Ø0.40 (0.016)	mm (in.)	

## Encoding Characteristics

Encoding characteristics are applicable per the Recommended Operating Conditions, unless otherwise specified. Values are for the worst case error over the full rotation.

### Encoder Resolution ≥ 4000 CPR

Parameter	Symbol	Min	Typ.*	Max	Units
Pulse Width Error	Δ <sub>P</sub>		21	45	°e
Logic State Width Error	Δ <sub>S</sub>		17	45	°e
Phase Error	Δ <sub>Φ</sub>		12	25	°e
Cycle Error	Δ <sub>C</sub>		36	60	°e
Index Pulse Width	P <sub>0</sub>	65	90	115	°e

### Encoder Resolution ≤ 2500 CPR

Parameter	Symbol	Min	Typ.*	Max	Units
Pulse Width Error	Δ <sub>P</sub>		20	30	°e
Logic State Width Error	Δ <sub>S</sub>		15	25	°e
Phase Error	Δ <sub>Φ</sub>		10	15	°e
Cycle Error	Δ <sub>C</sub>		17	30	°e
Index Pulse Width	P <sub>0</sub>	72	90	108	°e

\* Typical values specified at V<sub>CC</sub> = 5.0V and 25°C

## Electrical Characteristics

Electrical Characteristics over Recommended Operating Range

Parameter	Symbol	Min.	Typ.*	Max.	Units	Notes
Supply Current	I <sub>CC</sub>		30	85	mA	No load
High Level Output Voltage**	V <sub>OH</sub>	2.4	3.4		V	I <sub>OH</sub> = -20 mA
Low Level Output Voltage**	V <sub>OL</sub>		0.2	0.4	V	I <sub>OL</sub> = 20 mA
Rise Time	t <sub>r</sub>		10		ns	C <sub>L</sub> = 100 pF
Fall Time	t <sub>f</sub>		10		ns	C <sub>L</sub> = 100 pF

\* Typical values specified at V<sub>CC</sub> = 5.0 V and 25°C.

\*\* Refer to Texas Instruments AM26C31Q datasheet

## Mechanical Characteristics

Parameter	Symbol	Dimension	Tolerance <sup>[1]</sup>	Units
Codewheel Fits These Standard Shaft Diameters		2, 3, 4 5, 6, 8	g6	mm
		5/32, 1/8 3/16, 1/4	g6	in
Moment of Inertia	J	0.6 (8.0 x 10 <sup>-6</sup> )		g-cm <sup>2</sup> (oz-in-s <sup>2</sup> )
Required Shaft Length <sup>[2]</sup>		14.0 (0.55)	± 0.5 (± 0.02)	mm (in.)
Bolt Circle <sup>[3]</sup>	2 screw mounting	19.05 (0.750)	± 0.13 (± 0.005)	mm (in.)
	3 screw mounting	20.90 (0.823)	± 0.13 (± 0.005)	mm (in.)
	external mounting ears	46.0 (1.811)	± 0.13 (± 0.005)	mm (in.)
Mounting Screw Size <sup>[4]</sup>	2 screw mounting	M 2.5 or (2-56)		mm (in.)
	3 screw mounting	M 1.6 or (0-80)		mm (in.)
	external mounting ears	M 2.5 or (2-56)		mm (in.)
Encoder Base Plate Thickness		0.33 (0.130)		mm (in.)
Hub Set Screw		(2-56)		(in.)

Notes:

- These are tolerances required of the user.
- The AEDM-5805, 5905 provide an 8.9 mm (0.35 inch) diameter hole through the housing for longer motor shafts. See Ordering Information.
- The recommended mounting screw torque for 2 screw and external ear mounting is 1.0 kg-cm (0.88 in-lbs). The recommended mounting screw torque for 3 screw mounting is 0.50 kg-cm (0.43 in-lbs).

## Device Characteristics

Parameter	Characteristic	Note
Termination	10 conductor ribbon cable with 10 position IDC connector	See pin out diagram
Electrical Outputs	COMPLEMENTARY OUTPUTS: A, A/, B, B/, I, I/	
Line Driver Components	AM26C31QDR line driver IC, comes with decoupling capacitor on PC board.	

## Mounting Considerations

The AEDM-5xxx Series high resolution encoders must be aligned using the aligning pins as specified in Figure 2, or using the HEDS-8910 Alignment Tool as shown in Encoder Mounting and Assembly.

The AEDM-58xx can be mounted to a motor using either the two screw or three screw mounting option as shown in Figure 1. The optional aligning pins shown in Figure 2 can be used with either mounting option.

The AEDM-59xx have external mounting ears which may be used for mounting to larger motor base plates. Figure 3 shows the necessary mounting holes with optional aligning pins and motor boss.

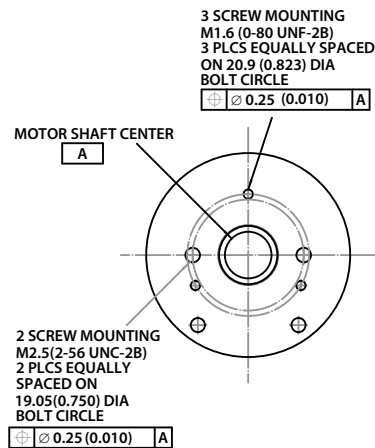

Figure 1. Mounting Holes

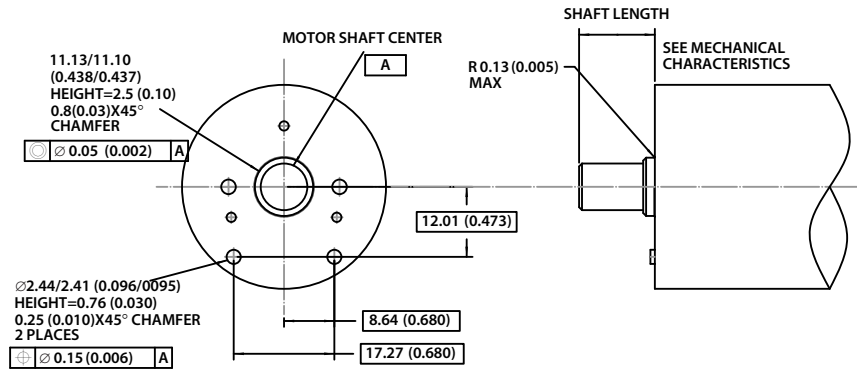

Figure 2. Optional Mounting Aids

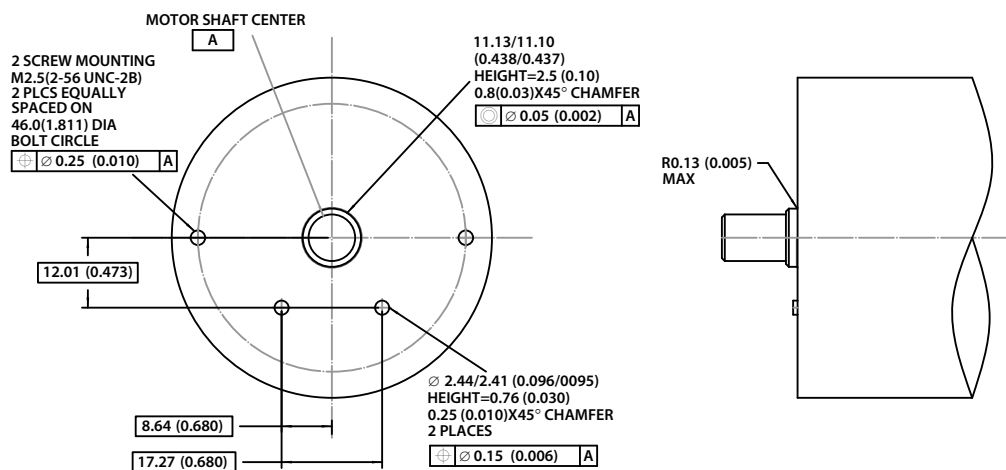
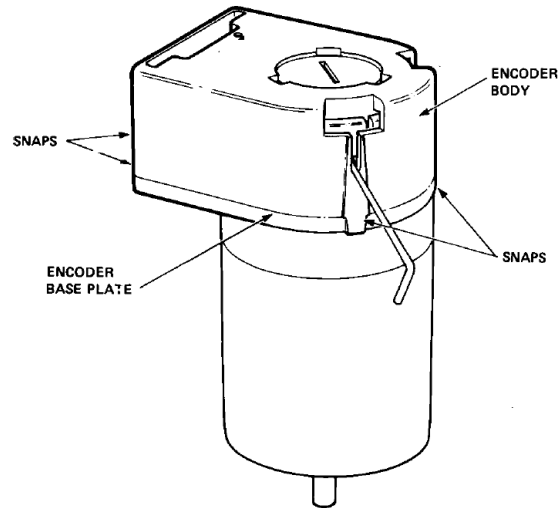
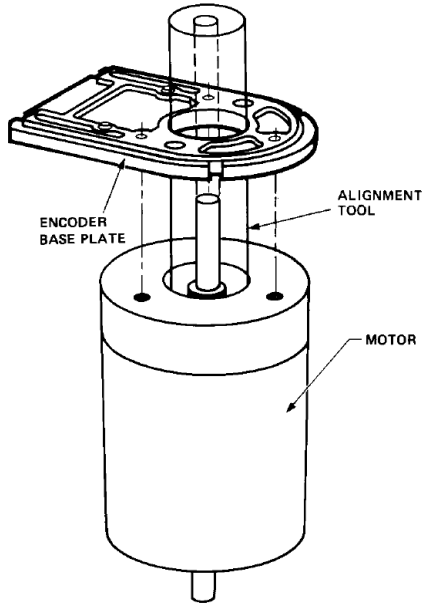

Figure 3. Mounting with external ears

## Encoder Mounting and Assembly

### Assembly process for AEDL-5xxx

1. Slide the alignment tool onto the motor shaft. With alignment tool in place, mount encoder baseplate onto motor as shown above. Ensure that the holes in the baseplate align with the mounting holes in the motor body. Insert and tighten mounting screws\* and remove alignment tool.
2. Snap encoder body onto base plate locking all 4 snaps.



- 3a. Insert the hex wrench into the body of the encoder. Ensure that it is properly seated into the code wheel hub set screws. Then apply a downward force on the end of the hex wrench. This sets the code wheel gap by levering the code wheel hub to its upper position.
- 3b. While continuing to apply a downward force, rotate the hex wrench in the clockwise direction until the hub set screw is tight\*\* against the motor shaft. The hub set screw attaches the code wheel to the motor's shaft.
- 3c. Remove the hex wrench by pulling it straight out of the encoder body.

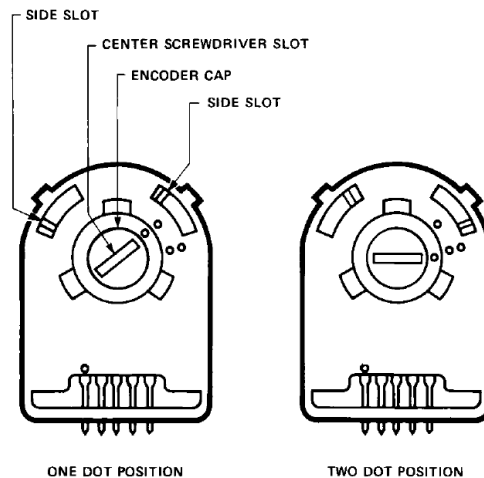
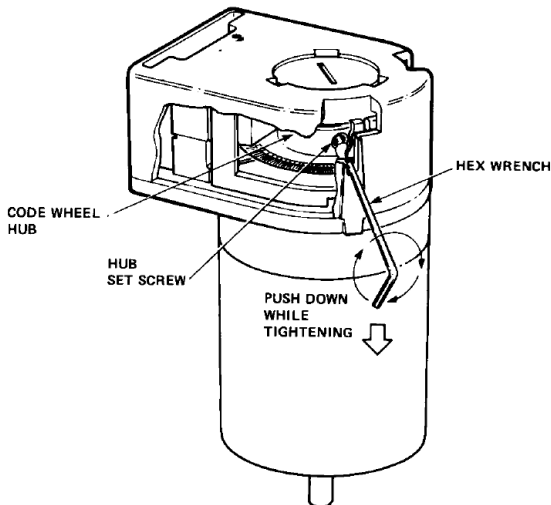

4. Use the center screwdriver slot, or either of the two side slots, to rotate the encoder cap dot clockwise from the one dot position to the two dot position. Do not rotate the encoder cap counterclockwise beyond the one dot position. The encoder is ready for use!

\* Adhesive should be applied to the screw-baseplate interface to prevent screws loosening due to the effect of vibration and high temperature on plastic. High temperature rated adhesive such as HERNON Ultra 317 is recommended.

\*\* The recommended torque to tighten the setscrew is 15-18 ozf.inch.